

REVISIONS				
REV.	ACC.	DESCRIPTION	DRN.	DATE
1		MODIFY BOT. ENGRAVED	VICTOR	3/16/10
2		MODIFY BOT. ENGRAVED	VICTOR	3/17/10

- NOTES:
1. TOP/BOTTOM HOUSING/ BUTTON MATERIA: HI-TEMP ABS PA-777D+UV (CHI-MEI), COLOR NATURAL BLACK.
  2. FINISH TEXTURE: MT-11010.
  3. HEAT STAKE BUTTON TO TOP HOUSING.

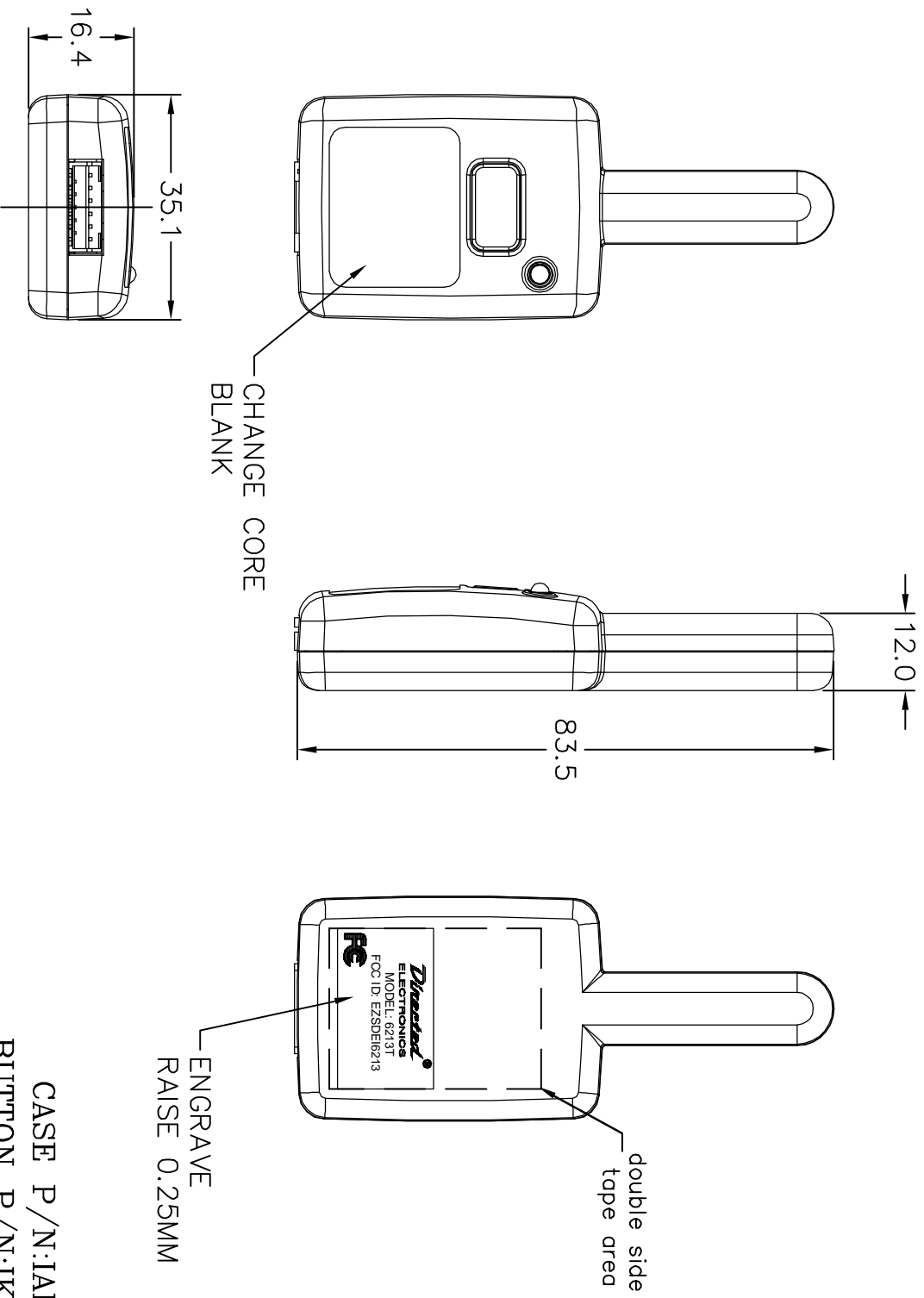

CASE P/N: IADHB004  
 BUTTON P/N: IKDHB000

BODY MATERIAL: HI-HEAT ABS+UV  
 1. Texture is same as  
 2. Radians will be if not specified.

\*Tolerance please refer specification of tolerance in the "C" and "F" column.

UNIT	A	B	C	D	E
mm &	0.08	0.16	0.30	0.40	0.40
6-30	0.10	0.20	0.40	0.40	0.40
30-150	0.20	0.40	0.40	0.40	0.40
150-500	0.40	0.80	0.80	0.80	0.80

SCALE: 1:1	UNIT: M/M	DRN BY: FELIX	DATE: 12/21/09	TITLE: NUTEK CORPORATION
MATERIAL:		CHK BY: VICTOR		DEL: 6213T IVU
FINISH:		APPD BY: VICTOR		DRAWING NO: 9710310-3
CODE:		SHEET: OF		REV: 2