

# TEST RESULT SUMMARY

## UNITED STATES STANDARD 47 CFR PART 15, SUBPART C

MANUFACTURER NAME	DIRECTED ELECTRONICS, INC.
NAME OF EQUIPMENT	470 Transmitter*
MODEL NUMBER	470
MANUFACTURER ADDRESS	2560 Progress Street Vista, CA 92083
TEST REPORT NUMBER	S8319-06
TEST DATE	25 June 1998

According to testing performed at TÜV Product Service, Inc., the above-mentioned unit is in compliance with the electromagnetic compatibility requirements defined in United States Standard 47 CFR Part 15, Subpart C, Paragraphs 15.207(a) and 15.209(a), 15.231(a)(1), (b), (c).

TÜV Product Service reports apply only to the specific sample tested under stated test conditions. It is the manufacturer's responsibility to assure the continued compliance of production units of this model. TÜV Product Service, Inc. shall have no liability for any deductions, inferences or generalizations drawn by the client or others from TÜV Product Service, Inc. issued reports.

As the responsible EMC Project/Division Managers, we hereby declare that the equipment tested at TÜV Product Service, Inc. as specified above conforms to the requirements of United States Standard 47 CFR Part 15, Radio Frequency Devices, Subpart C, Intentional Radiators.

Date: 29 June 1998

Location: San Diego, California  
USA

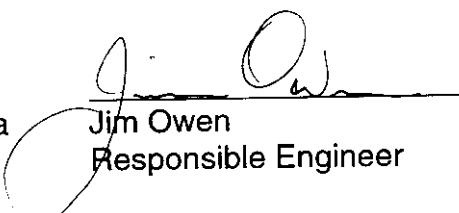
  
 Jim Owen  
 Responsible Engineer

  
 Floyd R. Fleury  
 EMC Manager, EIC

(\*) FCC ID: EZSDEI470

Not Transferable

# EMC EMISSION - TEST REPORT

## UNITED STATES STANDARD 47 CFR PART 15, SUBPART C

Test Report File No. : **S8319-06** Date of Issue: 29 June 1998

Model / Serial No. : 470 / #1

Product Type : 470 Transmitter\*

Applicant : DIRECTED ELECTRONICS, INC.

Manufacturer : ----

License holder : DIRECTED ELECTRONICS, INC.

Address : 2560 Progress Street  
: Vista, CA 92083

Test Result :  **Positive**  **Negative**

Test Project Number Reference(s) : **S901831901-06**

Total pages - Test Report : 12

(\*) FCC ID: EZSDEI470

*TÜV Product Service, Inc. is a subcontractor to TÜV Product Service, GmbH according to the principles outlined in ISO/IEC Guide 25 and EN 45001.*

*TÜV Product Service reports apply only to the specific sample tested under stated test conditions. It is the manufacturer's responsibility to assure the continued compliance of production units of this model. TÜV Product Service, Inc. shall have no liability for any deductions, inferences or generalizations drawn by the client or others from TÜV Product Service, Inc. issued reports.*

*This report is the confidential property of the client. As a mutual protection to our clients, the public and ourselves, extracts from the test report shall not be reproduced except in full without our written approval. This report shall not be used by the client to claim product endorsement by NVLAP or any agency of the US government.*

*TÜV Product Service, Inc. and its professional staff hold government and professional organization certifications and are members of AAMI, ACIL, AEA, ANSI, IEEE, NVLAP, and VCCI*

## DIRECTORY - EMISSIONS Test Report

		<b>Pages</b>
Test Report		<u>1 - 12</u>
Directory		<u>2</u>
Test Regulations		<u>3</u>
General Remarks and Summary		<u>12</u>
Equipment		<u>        </u>
Conducted Emissions	10/150/450 kHz - 30 MHz	<u>6</u>
Radiated Emissions	10 kHz - 30 MHz	<u>7</u>
Radiated Emissions	30 MHz - 1000 MHz	<u>8</u>
Interference Power	30 MHz - 300 MHz	<u>9</u>
Equivalent Radiated Emissions	1 GHz - 18 GHz	<u>10</u>

### Technical Documentation

Test Data Sheets and Test Setup Drawing(s)	<u>TD1</u>
--------------------------------------------	------------

### Appendices

<b>Appendix A</b>	<u>A1</u>
Test Setups (Photographs)	
<b>Appendix B</b>	<u>B1</u>
Product Information Form(s)	
<b>Appendix C</b>	<u>C1</u>
Change History	
<b>Appendix D</b>	<u>D1</u>
Supplemental Information	

**EMISSIONS TEST REGULATIONS :**

The emissions tests were performed according to the following regulations:

- EN 50081-1 / 1991
- EN 55011 / 1991
  - Group 1
  - Class A
- EN 55013 / 1990
  - Group 2
  - Class B
- EN 55014 / 1987
  - Household appliances and similar
  - Portable tools
  - Semiconductor devices
- EN 55014 / 1993
  - Household appliances and similar
  - Portable tools
  - Semiconductor devices
- EN 55015 / 1987
- EN 55015 / A1:1990
- EN 55015 / 1993
- EN 55022 / 1987
  - Class A
  - Class B
- EN 55022 / 1994
  - Class A
  - Class B
- BS
- VCCI
  - Class A ITE
  - Class B ITE
- 47 CFR Part 15, Subpart B
  - 107(b)
  - 107(a)
  - 107(e)
    - Class A
    - Class B
  - 109(b)
  - 109(a)
  - 109(g)
    - Class A
    - Class B
- 47 CFR Part 15, Subpart C
  - 207(a)
  - 209(a)
  - 231(a)(1)
  - 231(b)
  - 231(c)
- AS/NZS 3548: 1995
  - Class A
  - Class B
- CISPR 11 (1990)
  - Group 1
  - Class A
  - Group 2
  - Class B
- CISPR 22 (1993)
  - Class A
  - Class B

**Environmental Conditions In The Laboratory:**

	<u>Actual</u>
Temperature:	: 23 °C
Relative Humidity:	: 50 %
Atmospheric Pressure:	: 100.0 kPa

**Power Supply Utilized:**

Power supply system : Battery

**Symbol Definitions:**

- - Applicable
- - Not Applicable

### Emissions Test Conditions: CONDUCTED EMISSIONS (Interference Voltage)

The **CONDUCTED EMISSIONS (INTERFERENCE VOLTAGE)** measurements were performed at the following test location:

■ - Test not performed - see remarks

- SR-2, Shielded Room, 12' x 24' x 10', Metal Chamber
- SR-3, Shielded Room, 12' x 20' x 8', Metal Chamber
- SR-4, Shielded Room, 10' x 17' x 8', Copper Screen Chamber
- SR-5, Shielded Room, 16' x 28' x 15', Metal, Semi-Anechoic Chamber
- CSR-1, Shielded Room, 10' x 7' x 7', Metal Chamber

#### Test Equipment Used :

Model No.	Prop. No.	Description	Manufacturer	Serial No.
<input type="checkbox"/> - NM-7A, NM-17/27, NM-37/57, NM-67, CCA-7, & H/P 9836 HP-1B Computer	156, 162-166	Automated RFI Measurement System (ARMS), NO. 1	Eaton/Ailtech	(multiple)
<input type="checkbox"/> - NM-17/27, NM-37/57, CA-7, and H/P 9826 Computer	168, 170, 177, 178	Automated RFI Measurement System (ARMS), NO. 2	Eaton/Ailtech	(multiple)
<input type="checkbox"/> - H/P Spectrum Analyzer, Model 8568B; Display Section RF Analyzer Section; H/P 85650A, Quasi-Peak Adapter H/P Computer System, Model 310 with HP 85869A Software	187, 188	Automated RFI Measurement System (ARMS)	Various	(multiple)
<input type="checkbox"/> - LISN-3, 50 A	262-263	Power Mains Network (LISN), 50 $\mu$ H/250 $\mu$ H/50 $\Omega$ /0.25 $\mu$ F	Fischer Custom Communications, Inc.	3-4
<input type="checkbox"/> - LISN-3, 50 A	264, 265	Power Mains Network (LISN), 50 $\mu$ H/250 $\mu$ H/50 $\Omega$ /0.25 $\mu$ F	Fischer Custom Communications, Inc.	5-6
<input type="checkbox"/> - LISN-2, 25 A	413	Power Mains Network (LISN), 50 $\mu$ H/250 $\mu$ H/50 $\Omega$ /0.25 $\mu$ F	Fischer Custom Communications, Inc.	7
<input type="checkbox"/> - LISN-2, 25 A	--	Power Mains Network (LISN), 50 $\mu$ H/250 $\mu$ H/50 $\Omega$ /0.25 $\mu$ F	Fischer Custom Communications, Inc.	7
<input type="checkbox"/> - FCC-LISN-50-25-2	553	Power Mains Network (LISN), 50 $\mu$ H/250 $\mu$ H/50 $\Omega$ /0.25 $\mu$ F	Fischer Custom Communications, Inc.	112
<input type="checkbox"/> - FCC-LISN-50-25-2	552	Power Mains Network (LISN), 50 $\mu$ H/250 $\mu$ H/50 $\Omega$ /0.25 $\mu$ F	Fischer Custom Communications, Inc.	113
<input type="checkbox"/> - 8012-50-R-12-BNC	266	LISN, 50 $\mu$ H/50 $\Omega$ /0.1 $\mu$ F	Solar Electronics Co.	--
<input type="checkbox"/> - 9252-50-R-24-BNC	458	LISN, 50 $\mu$ H /250 $\mu$ H/50 $\Omega$ /0.25 $\mu$ F	Solar Electronics Co.	941719
<input type="checkbox"/> - 9252-50-R-24-BNC	457	LISN, 50 $\mu$ H /250 $\mu$ H/50 $\Omega$ /0.25 $\mu$ F	Solar Electronics Co.	941720
<input type="checkbox"/> - MDS-21	277	Absorbing Clamp	Rohde & Schwarz	821023
<input type="checkbox"/> - ESHS 20	428	EMI Test Receiver	Rohde & Schwarz	837055/00 1
<input type="checkbox"/> - ESHS 30	459	EMI Test Receiver	Rohde & Schwarz	832354/00 4
<input type="checkbox"/> - CAT-20	598	20 dB Attenuator	Mini-Circuits	--
<input type="checkbox"/> - CAT-20	615	20 dB Attenuator	Mini-Circuits	--

Remarks: EUT battery operated.

**Emissions Test Conditions: RADIATED EMISSIONS (Magnetic Field)**

The *RADIATED EMISSIONS (MAGNETIC FIELD)* measurements were performed at the following test location:

■ - Test not applicable

- SR-2, Shielded Room, 12' x 24' x 10', Metal Chamber
- SR-3, Shielded Room, 12' x 20' x 8', Metal Chamber
- SR-4, Shielded Room, 10' x 17' x 8', Copper Screen Chamber
- SR-5, Shielded Room, 16' x 28' x 15', Metal, Semi-Anechoic Chamber
- TR-1, Shielded Room, 16.5' x 10' x 7.5', Copper Screen Chamber
- CSR-1, Shielded Room, 10' x 7' x 7', Metal Chamber

Testing was performed at a test distance of :

- 3 meters
- 30 meters

**Test Equipment Used :**

Model No.	Prop. No.	Description	Manufacturer	Serial No.
<input type="checkbox"/> - NM-7A, NM-17/27, NM-37/57, NM-57, CCA-7, and H/P 9836 HP-1B Computer	136, 162-165	Automated RFI Measurement System (ARMS), NO. 1	Eaton/Ailtech	(multiple)
<input type="checkbox"/> - NM-17/27, NM-37/57, CA-7, & H/P 9836 Computer	168, 170, 177, 178	Automated RFI Measurement System (ARMS), NO. 2	Eaton/Ailtech	(multiple)
<input type="checkbox"/> - AT-205/URM-5	201	Loop Antenna	Eaton/Ailtech	64090
<input type="checkbox"/> - 94593-1	205	Loop Antenna	Eaton/Ailtech	0264

NOT APPLICABLE

Remarks: \_\_\_\_\_

**Emissions Test Conditions: RADIATED EMISSIONS (Electric Field)**

The *RADIATED EMISSIONS (ELECTRIC FIELD)* measurements, in the frequency range of 30 MHz-1000 MHz, were tested in a horizontal and vertical polarization at the following test location :

■ - Test not performed - see remarks

- Roof (Small Open Area Test Site)
- Canyon #1 (10- and 30-Meter Open Area Test Site), Carroll Canyon, San Diego
- Canyon #2 (3- and 10-Meter Open Area Test Site), Carroll Canyon, San Diego

**Testing was performed at a test distance of :**

- 3 meters
- 10 meters
- 30 meters

**Test Equipment Used :**

Model No.	Prop. No.	Description	Manufacturer	Serial No.
<input type="checkbox"/> - NM-37/57A CCA-7	420 373	OATS measurement set (Roof)	Eaton/Ailtech	0561-09261 0773-03117
<input type="checkbox"/> - NM-37/57 CCA-7	171 172	OATS measurement set (Canyon)	Eaton/Ailtech	0709-82078 0187-0322
<input type="checkbox"/> - HFH 2-Z2	208	Antenna, Loop	Rohde & Schwarz	880
<input type="checkbox"/> - 3104	235	Antenna, Biconical	EMCO	3031
<input type="checkbox"/> - 3110	451	Antenna, Biconical	EMCO	1378
<input type="checkbox"/> - 94455-1	231	Antenna, Biconical	Eaton/Ailtech	0811
<input type="checkbox"/> - 3110B	491	Antenna, Biconical	EMCO	9508-2
<input type="checkbox"/> - CBL6111	460	Antenna, Bilog	Chase	1013
<input type="checkbox"/> - CBL6111	461	Antenna, Bilog	Chase	1291
<input type="checkbox"/> - 3146	242	Antenna, Log Periodic Dipole	EMCO	1597
<input type="checkbox"/> - 3146	243	Antenna, Log Periodic Dipole	EMCO	106X
<input type="checkbox"/> - 3146	244	Antenna, Log Periodic Dipole	EMCO	1063
<input type="checkbox"/> - 7405	570	Loop Probes	EMCO	9104-1959
<input type="checkbox"/> - 8566B	404	Spectrum Analyzer	Hewlett Packard	2311A02209
<input type="checkbox"/> - 85662B	406	Spectrum Analyzer Display	Hewlett Packard	2309A04682
<input type="checkbox"/> - ESVS 30	427	EMI Test Receiver	Rohde & Schwarz	830350/006
<input type="checkbox"/> - ESVS 30	466	EMI Test Receiver	Rohde & Schwarz	833825/003

Remarks: Prescan in shielded room detected no measurable emissions from 30 MHz - 1 GHz.



**Emissions Test Conditions: INTERFERENCE POWER**

The *INTERFERENCE POWER* measurements were performed by using the absorbing clamp on the mains and interface cables in the frequency range 30 MHz - 300 MHz at the following test location :

■ - Test not applicable

- SR-2, Shielded Room, 12' x 24' x 10', Metal Chamber
- SR-3, Shielded Room, 12' x 20' x 8', Metal Chamber
- SR-4, Shielded Room, 10' x 17' x 8', Copper Screen Chamber
- SR-5, Shielded Room, 16' x 28' x 15', Metal, Semi-Anechoic Chamber
- CSR-1, Shielded Room, 10' x 7' x 7', Metal Chamber

**Test Equipment Used :**

Model No.	Prop. No.	Description	Manufacturer	Serial No.
<input type="checkbox"/> - MDS-21	277	Absorbing Clamp	Rohde & Schwarz	821023
<input type="checkbox"/> - NM-7A, NM-17/27, NM-37/57, NM-67, CCA-7, & H/P 9836 HP-1B Computer	156, 162-166	Automated RFI Measurement System (ARMS), NO. 1	Eaton/Aitech	(multiple)
<input type="checkbox"/> - NM-17/27, NM-37/57, CA-7, & H/P 9825 Computer	168-170, 171-178	Automated RFI Measurement System (ARMS), NO. 2	Eaton/Aitech	(multiple)
<input type="checkbox"/> - H/P Spectrum Analyzer, Model 8568B, Display Section RF Analyzer Section, H/P 85650A, Quasi-Peak Adapter H/P Computer System, Model 310 with HP 85869A Software	187-188	Automated RFI Measurement System (ARMS)	Hewlett Packard	2304A04531 2304A02500 2811A01325
<input type="checkbox"/> - ESVS 30	427	EMI Test Receiver	Rohde & Schwarz	830350/006
<input type="checkbox"/> - ESVS 30	466	EMI Test Receiver	Rohde & Schwarz	830350/003

NOT APPLICABLE

Remarks: \_\_\_\_\_

**Emissions Test Conditions: RADIATED EMISSIONS (FCC Part 15, 15.231)**

The *EQUIVALENT RADIATED EMISSIONS* measurements were performed at the following test location :

- Test not applicable

- - Roof (Small Open Area Test Site)
- Canyon #1 (10- and 30-Meter Open Area Test Site), Carroll Canyon, San Diego
- Canyon #2 (3- and 10-Meter Open Area Test Site), Carroll Canyon, San Diego

**Testing was performed at a test distance of:**

- 1 meters
- - 3 meters
- 10 meters

**Test Equipment Used :**

Model No.	Prop. No.	Description	Manufacturer	Serial No.
■ - 8566	407	Spectrum Analyzer	Hewlett Packard	2311A02209
■ - 85662B	406	Spectrum Analyzer Display	Hewlett Packard	2309A04682
<input type="checkbox"/> - 3115	453	Antenna, Double Ridge Guide	EMCO	9412-4363
■ - 3115	251	Antenna, Double Ridge Guide	EMCO	2495
■ - 3146	243	Antenna, Log Periodic Dipole	EMCO	106Z
<input type="checkbox"/> - 3110	451	Broadband Antenna	EMCO	1378
■ - AFD3-0208-40-ST	367	Pre-amplifier, 2 - 8 GHz	Miteq, Inc.	155382
■ - ZJL-3G	469	Pre-amplifier, 1 - 2 GHz	MiniCircuits	--
<input type="checkbox"/> - 91889-2	253	Horn Antenna (2 to 3.6 GHz)	Eaton	101
<input type="checkbox"/> - 91892-1	254	Reflector Antenna (3.6 to 18 GHz)	Eaton	--
<input type="checkbox"/> - 94613-1	255	Horn Antenna (3.6 to 7.6 GHz)	Eaton	--
<input type="checkbox"/> - 91891-2	256	Horn Antenna (7.3 to 12 GHz)	Eaton	--
<input type="checkbox"/> - 94614-1	257	Horn Antenna (12 to 18 GHz)	Eaton	--

Remarks: \_\_\_\_\_

**Equipment Under Test (EUT) Test Operation Mode - Emissions Tests :**

The equipment under test was operated under the following conditions during emissions testing:

- Standby
- Test Program (H - Pattern)
- Test Program (Color Bar)
- Test Program (Customer Specified)
- Practice Operation
- Normal Operating Mode
- Transmit

**Configuration of the equipment under test:**

- See Constructional Data Form in Appendix B - Page B2
- See Product Information Form(s) in Appendix B - Page B2

**The following peripheral devices and interface cables were connected during the testing:**

- \_\_\_\_\_ Type : \_\_\_\_\_
- \_\_\_\_\_ Type : \_\_\_\_\_
- \_\_\_\_\_ Type : \_\_\_\_\_
- \_\_\_\_\_ Type : \_\_\_\_\_
- \_\_\_\_\_ Type : \_\_\_\_\_
- \_\_\_\_\_ Type : \_\_\_\_\_
- \_\_\_\_\_ Type : \_\_\_\_\_
- \_\_\_\_\_ Type : \_\_\_\_\_
- unshielded power cable
- unshielded cables
- shielded cables                      MPS.No.: \_\_\_\_\_
- customer specific cables
- \_\_\_\_\_
- \_\_\_\_\_

**Emissions Test Results:**

**Conducted Emissions, 10/150/450 kHz - 30 MHz**

- PASS       - FAIL       - NOT APPLICABLE

Minimum limit margin \_\_\_\_\_ dB      at \_\_\_\_\_ MHz

Maximum limit exceeding \_\_\_\_\_ dB      at \_\_\_\_\_ MHz

Remarks: EUT battery operated.

**Radiated Emissions (Magnetic Field), 10 kHz - 30 MHz**

- PASS       - FAIL       - NOT APPLICABLE

Minimum limit margin \_\_\_\_\_ dB      at \_\_\_\_\_ MHz

Maximum limit exceeding \_\_\_\_\_ dB      at \_\_\_\_\_ MHz

Remarks: \_\_\_\_\_

**Radiated Emissions (Electric Field), 30 MHz - 1000 MHz**

- PASS       - FAIL       - NOT APPLICABLE

Minimum limit margin \_\_\_\_\_ dB      at \_\_\_\_\_ MHz

Maximum limit exceeding \_\_\_\_\_ dB      at \_\_\_\_\_ MHz

Remarks: Prescan in shielded room detected no measurable emissions from 30 MHz - 1 GHz.

**Equivalent Radiated Emissions**

- PASS       - FAIL       - NOT APPLICABLE

Minimum limit margin \_\_\_\_\_ 3.4 dB      at \_\_\_\_\_ 433.82 MHz

Maximum limit exceeding \_\_\_\_\_ dB      at \_\_\_\_\_ MHz

Remarks: \_\_\_\_\_

**GENERAL REMARKS:**

- (\*) Conducted Emissions - EUT battery operated.  
Radiated Emissions - Prescan in shielded room detected no measurable emissions from 30 MHz - 1 GHz.  
Part 15, Paragraph 15.231(a)(1) - Transmitter deactivated in less than one second. ✓

**SUMMARY:**

All tests according to the regulations cited on page 3 were

- Performed
- **Not Performed\***

The Equipment Under Test

- **Fulfills** the general approval requirements cited on page 3.
- **Does not** fulfill the general approval requirements cited on page 3.

**Statement of Measurement Uncertainty**

The data and results referenced in this document are true and accurate. There may be some degree or level of measurement uncertainty. As EN 45001 does not allow recommendations to be included in the test report, the reader is encouraged to request a copy of the TÜV policy concerning pass or fail judgment with respect to possible measurement uncertainties.

Equipment Received Date: 25 June 1998

Testing Start Date: 25 June 1998

Testing End Date: 25 June 1998

- TÜV PRODUCT SERVICE, INC. -

Responsible Engineer:

\_\_\_\_\_  
Jim Owen  
(EMC Engineer)

Responsible Test Engineer:

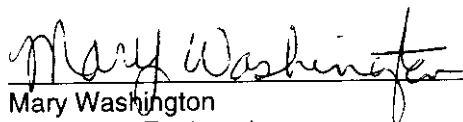
  
\_\_\_\_\_  
Mary Washington  
(EMC Test Engineer)

## Technical Documentation

Test Data Sheets

and

Test Setup Drawing(s)

DATE: 25 June 1998  
SPECIFICATION: FCC Part 15, Paragraph 15.209(a)

CUSTOMER: DIRECTED ELECTRONICS, INC.  
EUT: 470 Transmitter  
NOTE: Radiated Prescan

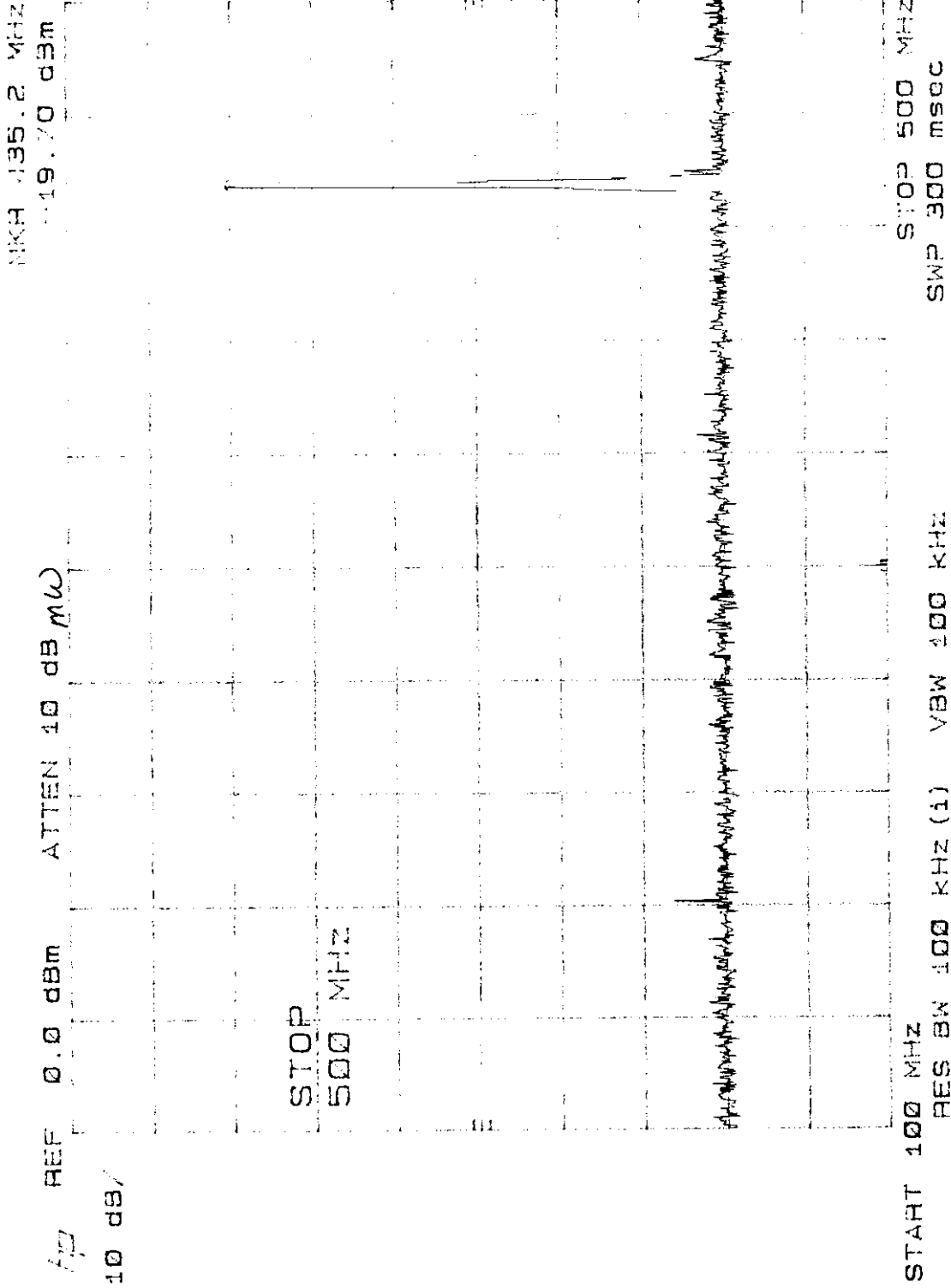

CUSTOMER: DIRECTED ELECTRONICS, INC.  
EUT: 470 Transmitter  
NOTE: Radiated Prescan

DATE: 25 June 1998  
SPECIFICATION: FCC Part 15, Paragraph 15.209(a)

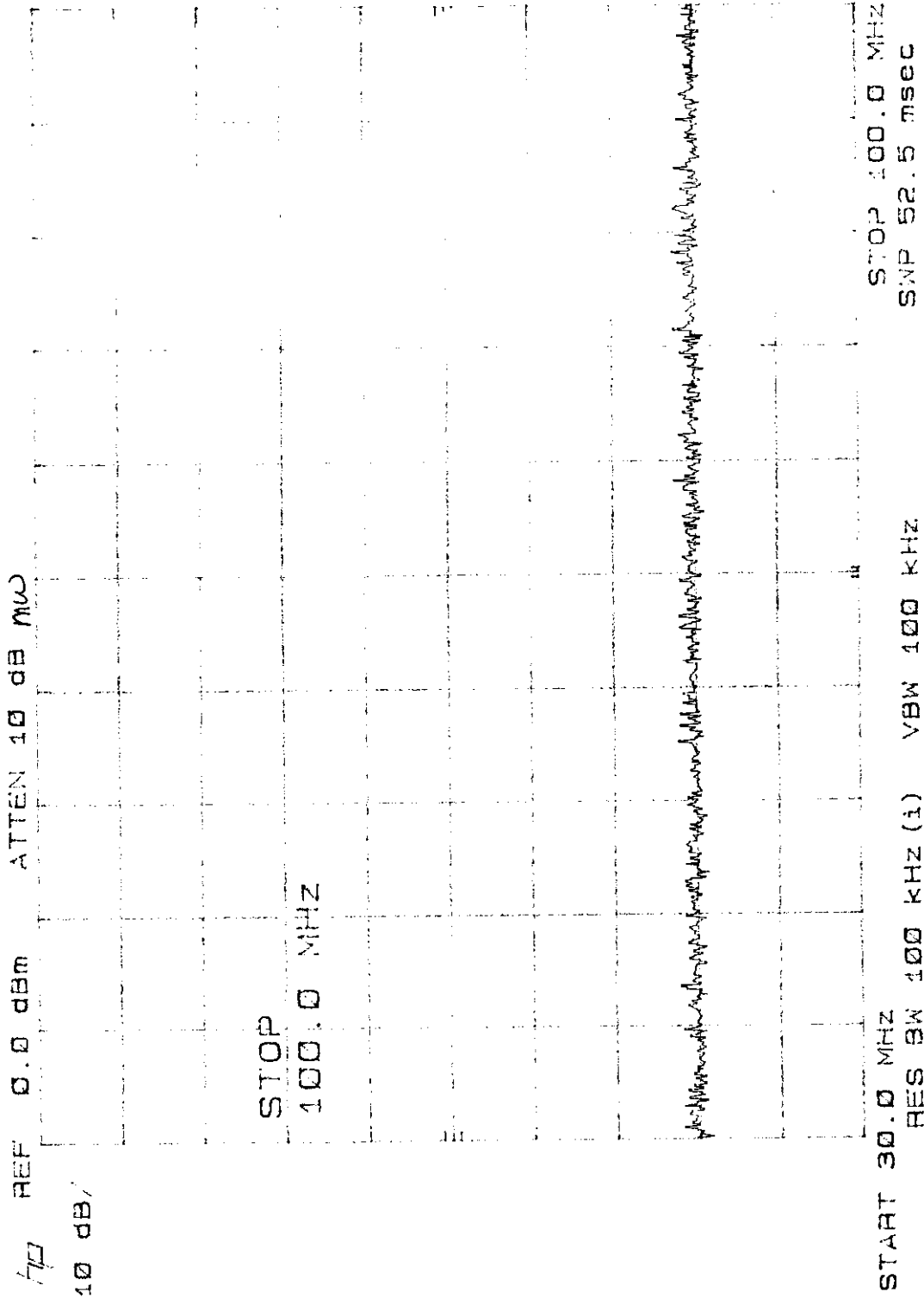



DATE: 25 June 1998  
SPECIFICATION: FCC Part 15, Paragraph 15.209(a)

CUSTOMER: DIRECTED ELECTRONICS, INC.  
EUT: 470 Transmitter  
NOTE: Radiated Prescan

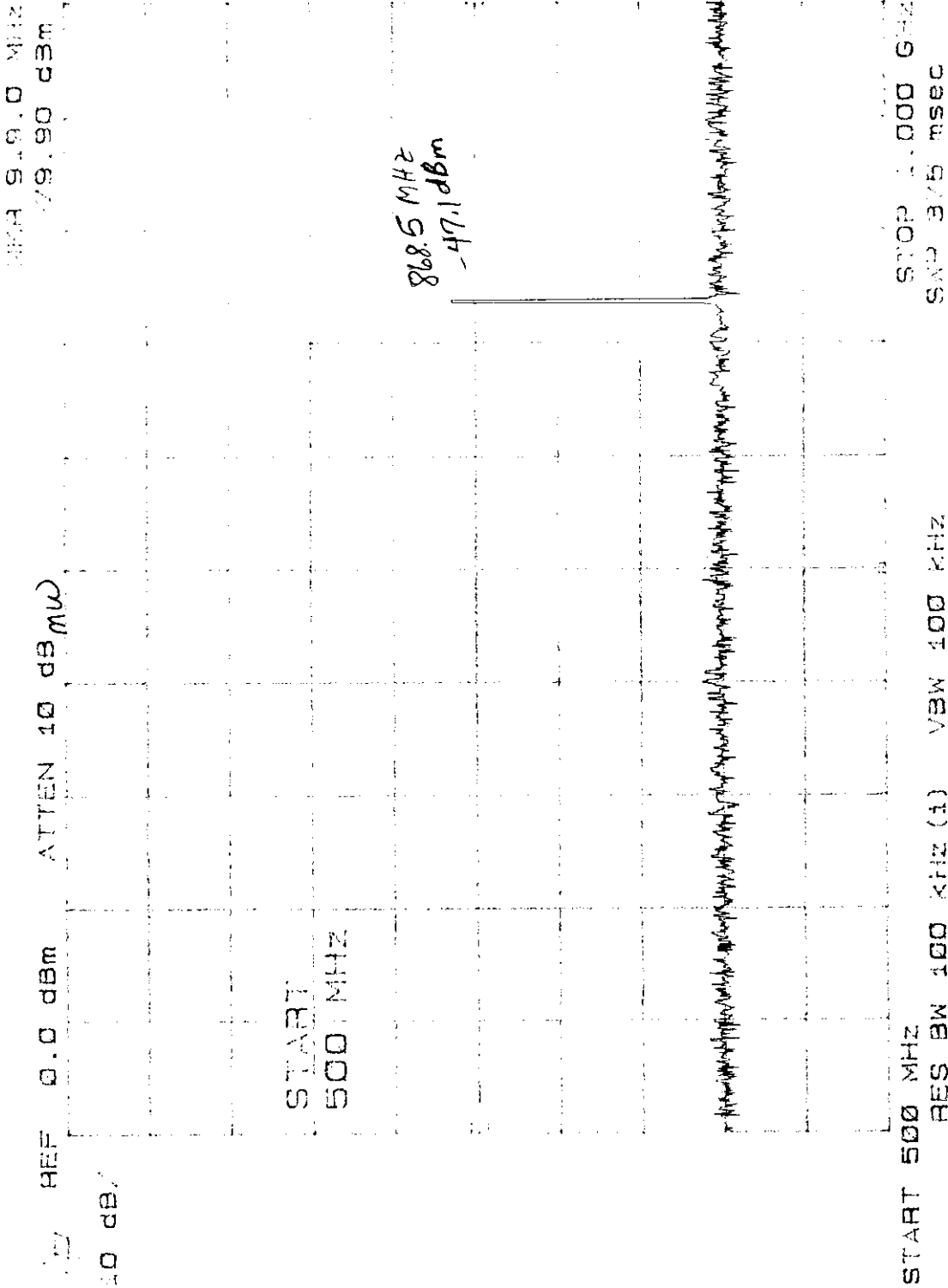

REPORT No: S8319 TESTED BY: mw *mw* SPEC: FCC Part 15 para 15.231(b)

CUSTOMER: Directed Electronics, Inc. TEST DIST: 3 Meters

E U T: Transmitter 470 TEST SITE: 3

EUT MODE: Transmit BICONICAL: N/A

DATE: 25-Jun-98 LOG PERIODIC: 243

NOTES: Duty Cycle= 55% OTHER: 251  
 RBW and VBW = 100 kHz below 1 GHz.  
 RBW and VBW = 1 MHz above 1 GHz.

FREQ (MHz)	VERTICAL (dBuv)		HORIZONTAL (dBuv)		CORRECTION FACTOR (dB/m)	MAX LEVEL (dBuV/m)		SPEC LIMIT (dBuV/m)		MARGIN (dB)		EUT Rotatio	Antenna Height
	pk	av	pk	av		pk	av	pk	av	pk	av		
433.82	50.3	45.2	66.4	61.3	16.1	82.5	77.4	100.8	80.8	-18.3	-3.4	0	1
867.64	23.3	18.2	37.1	32	23.1	60.2	55.0	80.8	60.8	-20.6	-5.8	25	1
1301.46	35.9	30.8	38.2	33.1	9.7	47.9	42.7	74	54	-26.1	-11.3	0	1
1735.28	34.4	29.3	34.1	29	12.9	47.3	42.1	80.8	60.8	-33.5	-18.7		
2169.1	44.5	39.4	46.15	41	2.5	48.6	43.5	80.8	60.8	-32.2	-17.3		
2602.92	41.7	36.6	40.55	35.4	2.5	44.2	39.0	80.8	60.8	-36.6	-21.8		
3036.74	37.1	32	36.9	31.8	5.8	42.9	37.8	80.8	60.8	-37.9	-23.0		
3470.56	36.85	31.7	36.4	31.3	5.7	42.5	37.4	80.8	60.8	-38.3	-23.4		
3904.38	37.55	32.4	38.1	33	7.1	45.2	40.1	74	54	-28.8	-13.9		
4338.2	36.4	31.3	37.05	31.9	11.9	48.9	43.8	80.8	60.8	-31.9	-17.0		

DATE: 25 June 1998  
SPECIFICATION: FCC Part 15, Paragraph 15.209(a)

CUSTOMER: DIRECTED ELECTRONICS, INC.  
EUT: 470 Transmitter  
NOTE: 20 dB Bandwidth

MARKER  $\Delta$  244 KHZ  
0.00 dB

REF 107.0 dBmW ATTEN 10 dBmW

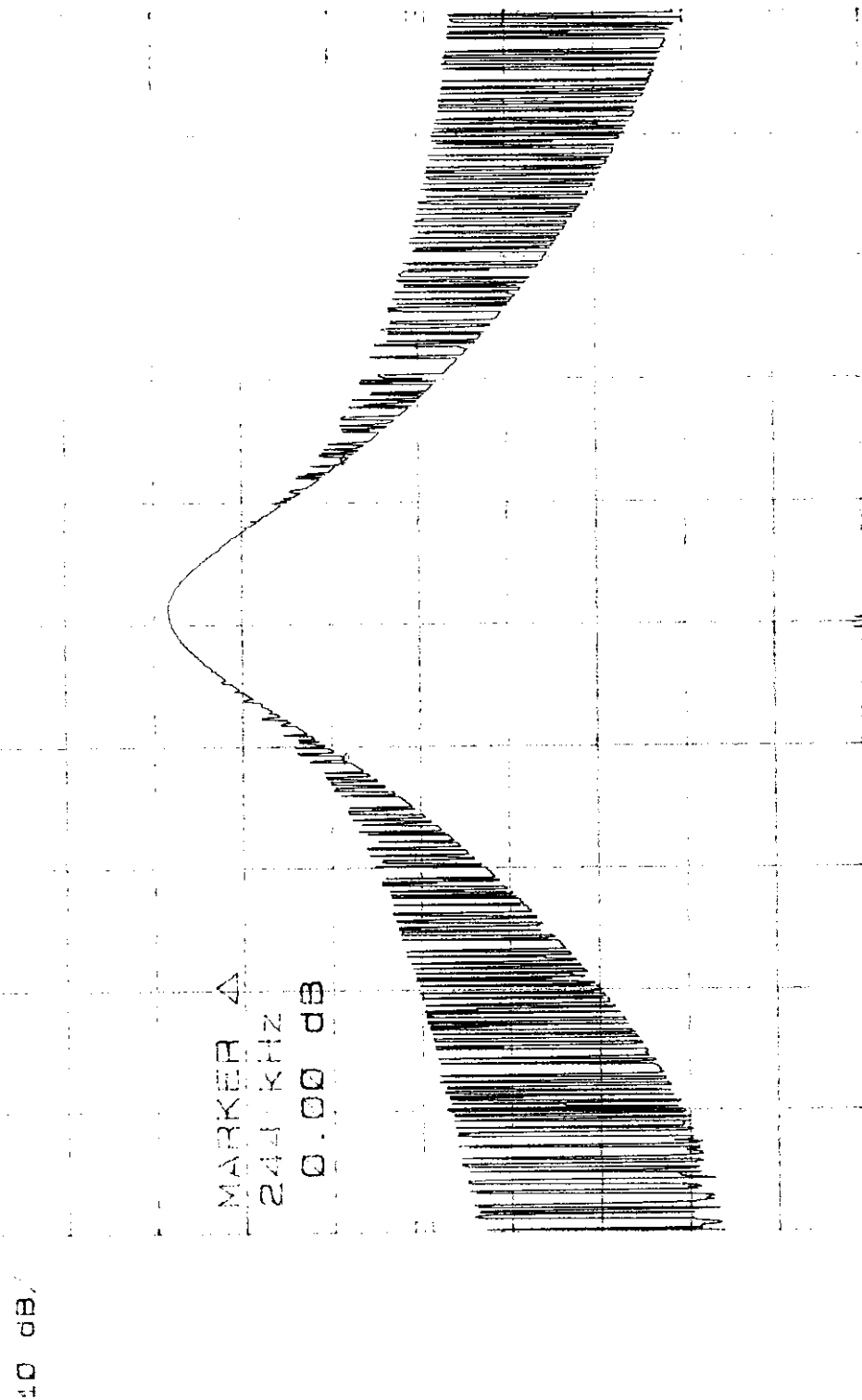

MARKER  $\Delta$   
244 KHZ  
0.00 dB

SPAN 1.00 MHz  
SWP 20.0 msec

CENTER 433.80 MHz  
RES BW 100 KHZ (1) VBW 100 KHZ

10 dB

**Appendix A**

Test Setups  
(Photographs)

## Appendix B

Product Information Form(s)

CUSTOMER INFORMATION				
COMPANY NAME:		DIRECTED ELECTRONICS, INC.		
COMPANY ADDRESS:		2560 Progress Street		
		Vista, CA 92083		
PHONE NUMBER:		760 599 1366		
FAX NUMBER/E-MAIL ADDRESS:		760 599 1380; marting@directed.com		
CUSTOMER CONTACT:		Martin Gonzales		
PRODUCT DESCRIPTION				
NAME, MODEL, SERIAL # OF EUT:		470 Transmitter, Model 470 (FCC ID: EZSDEI470)		
DESCRIPTION OF EUT:		Automotive security system transmitter		
Components of EUT				
Description	Model Number	Serial Number	FCC ID Number	
N/A				
OPERATING MODE(S):		Transmitting		
I/O CABLES		N/A		
POWER CORDS		N/A		
POWER INTERFACE				
FREQUENCY/AC/DC VOLTAGE:		12 Vdc		
PHASES/CURRENT:		-- / --		
OSCILLATOR FREQUENCIES				
FREQUENCY	EUT LOCATION	DESCRIPTION OF USE		
433.92	--	--		
POWER SUPPLY				
DESCRIPTION	MANUFACTURER	MODEL #	SERIAL #	SWITCHING/LINEAR FREQ.
12 Vdc battery				
POWER LINE FILTERS				
MANUFACTURER	MODEL NO.	QTY.	LOCATION ON EUT	
N/A				
CRITICAL EMI COMPONENTS				
DESCRIPTION	MANUFACTURER	PART # OR VALUE	QTY.	LOCATION ON EUT
N/A				
DESCRIPTION OF ENCLOSURE:		ABS plastic		
INTERFACING AND/OR SIMULATORS PERIPHERAL EQUIPMENT:				
DESCRIPTION	MANUFACTURER	MODEL #	SERIAL #	FCC ID
N/A				
<b>BLOCK DIAGRAM:</b>		See page B3.		

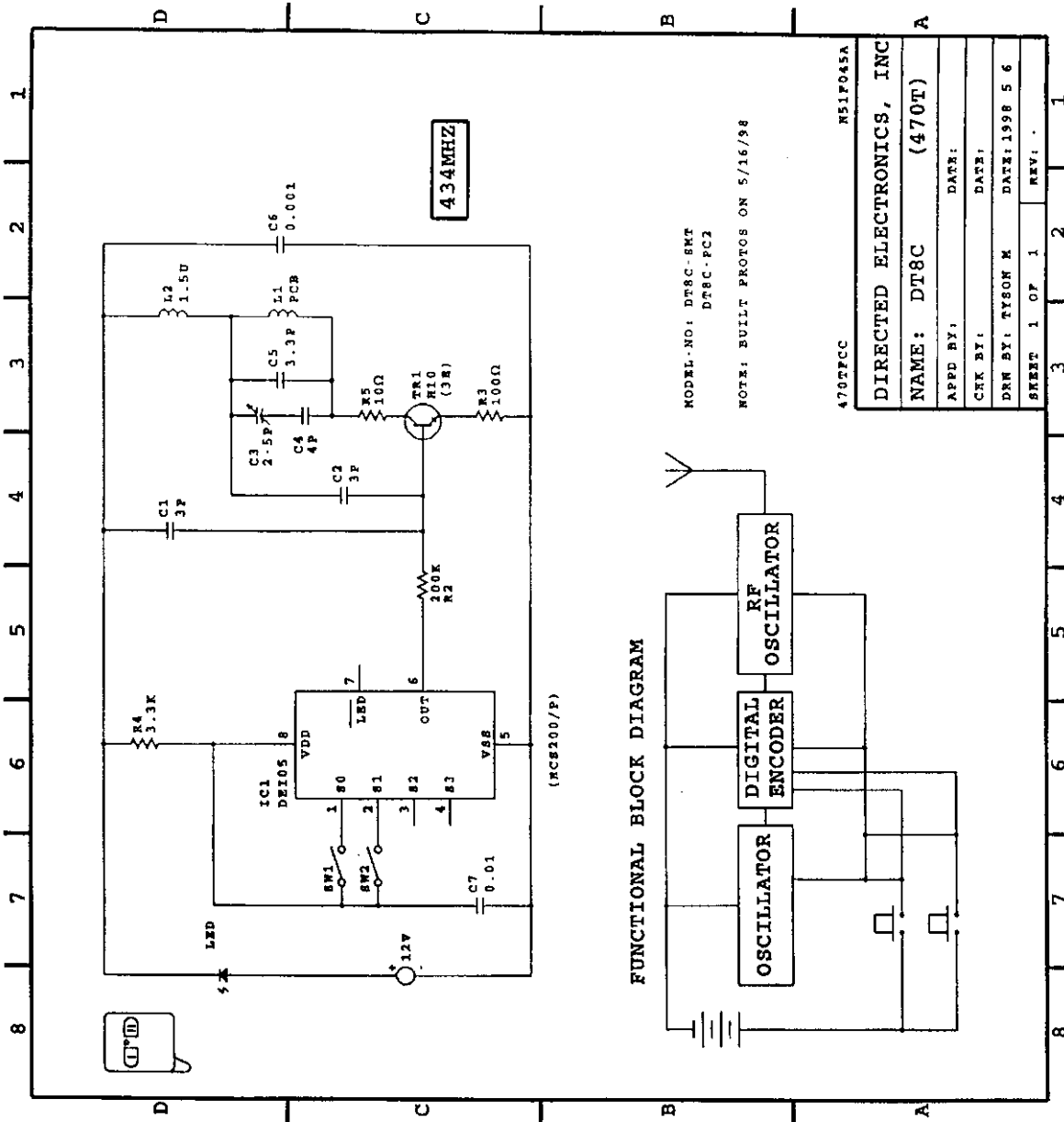

**Appendix C**

Change History

**Not Applicable**



## Appendix D

Supplemental Information

## Duty Cycle Correction for Intentional Radiators

Maximum time the EUT is on in 100ms.

Duty cycle correction, dB = 20 log (DC)

$$DC = (\text{Max. time data is on in } 100\text{ms} \div 100\text{ms})(\text{Max. duty cycle})$$

Example from our unit and measured data

$$\begin{aligned} DC &= [(78\text{ms} + 10\text{ms}) \div 100\text{ms}] (.780\text{ms} \div 1.24\text{ms}) \\ &= (88\text{ms} \div 100\text{ms}) (.780\text{ms} \div 1.24\text{ms}) \\ &= (.88) (.629) \\ &= .55352 \end{aligned}$$

$$\begin{aligned} \text{dB} &= 20 \log (\text{DC}) \\ &= 20 \log (.55352) \\ &= -5.14 \end{aligned}$$

"Max. time data is on in 100ms" refers to how many word or words are transmitted in 100ms and the length of those words added together. "Max. duty cycle" refers to the maximum bit length divided by the period of a pulse for the words recorded. Use measured data as example.

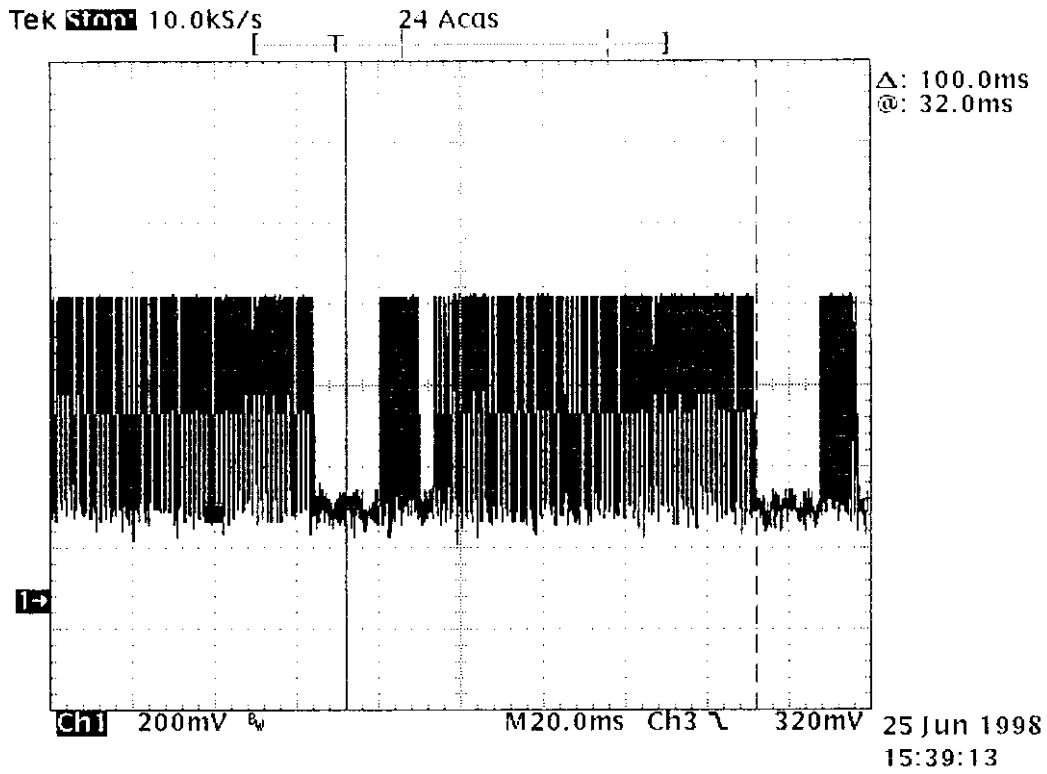

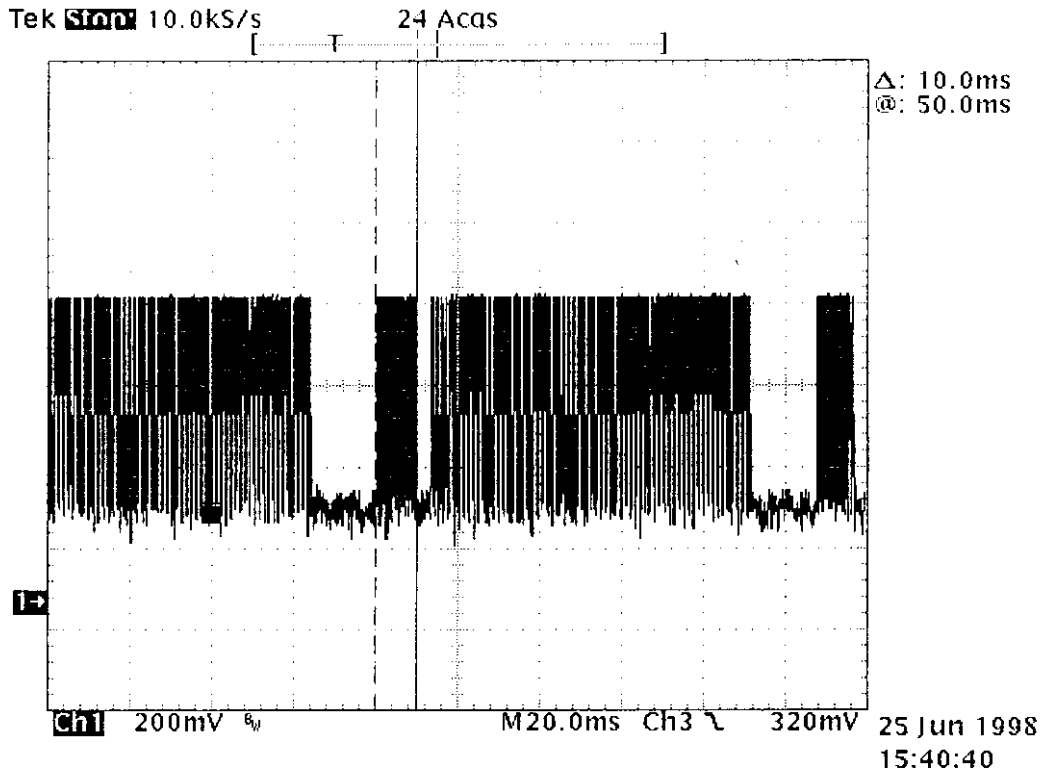

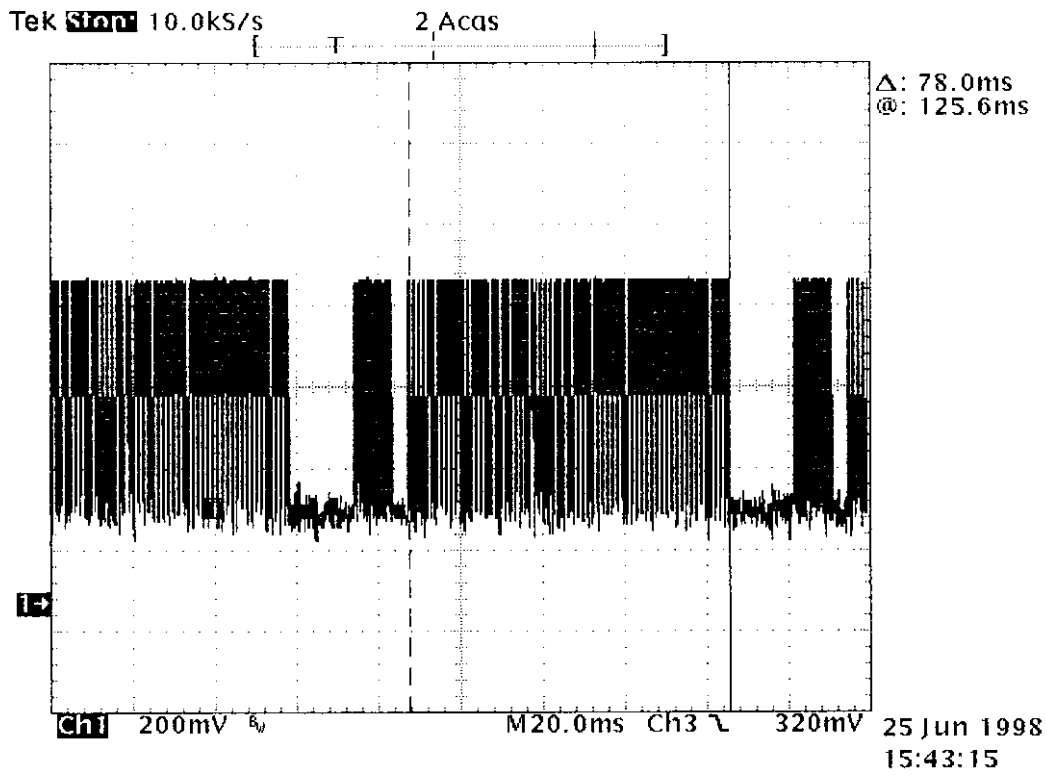

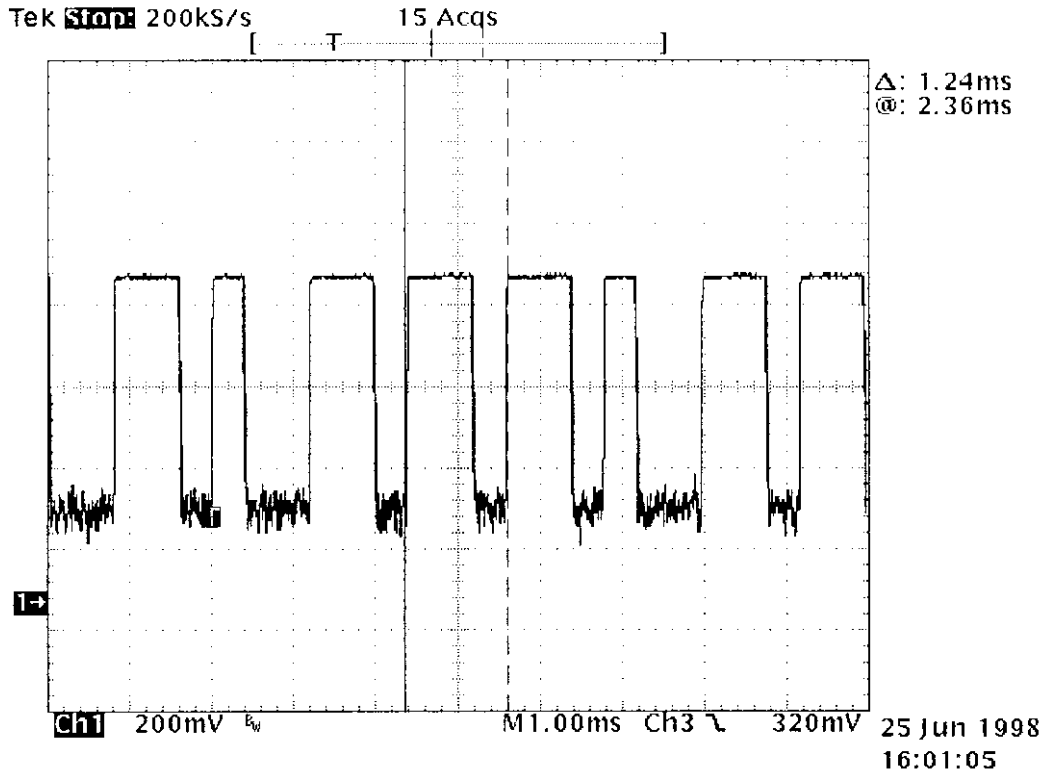

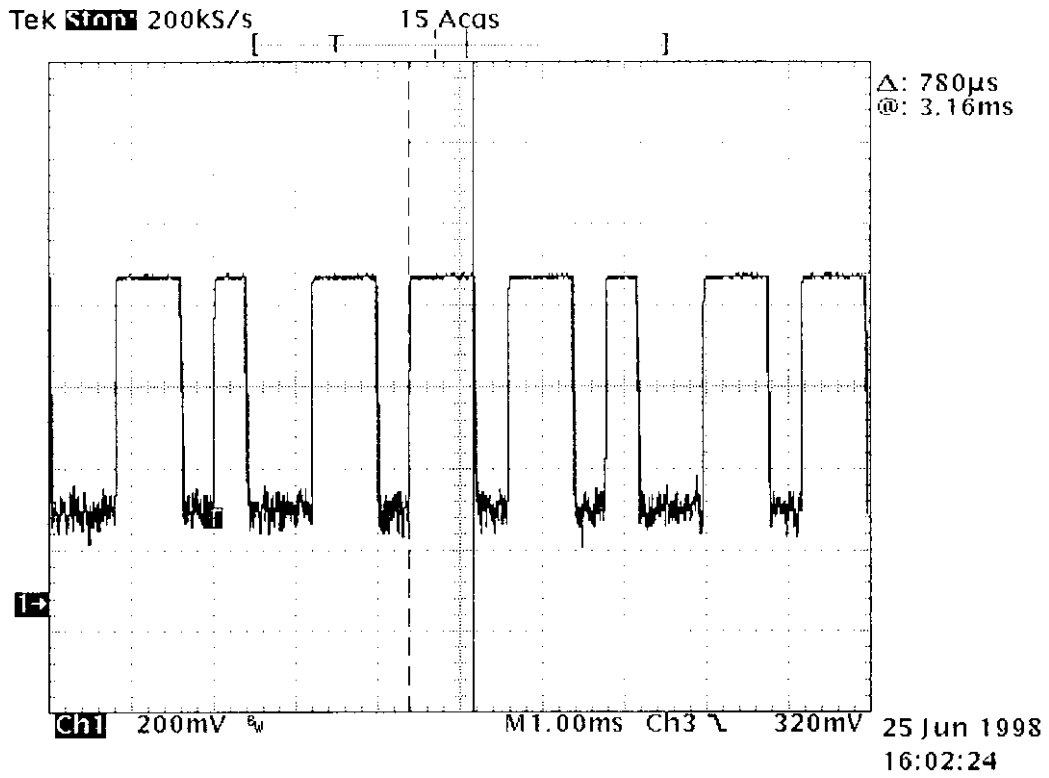

## Appendix E

Calibration Dates



**Emissions Test Conditions: CONDUCTED EMISSIONS (Interference Voltage)**

Model No.	Prop. #	Description	Manufacturer	Serial #	Cal Date
H/P Spectrum Analyzer, Model 8568B; Display Section RF Analyzer Section; H/P 85650A, Quasi-Peak Adapter H/P Computer System, Model 310 with HP 85869A Software	187, 188	Automated RFI Measurement System (ARMS)	Various	(multiple)	10/1/98
LISN-3, 50 A	262-263	Power Mains Network (LISN), 50 $\mu$ H/250 $\mu$ H/50 $\Omega$ /0.25 $\mu$ F	Fischer Custom Communications, Inc.	3-4	02/22/99
LISN-3, 50 A	264, 265	Power Mains Network (LISN), 50 $\mu$ H/250 $\mu$ H/50 $\Omega$ /0.25 $\mu$ F	Fischer Custom Communications, Inc.	5-6	02/22/99
FCC-LISN-50-25-2	553	Power Mains Network (LISN), 50 $\mu$ H/250 $\mu$ H/50 $\Omega$ /0.25 $\mu$ F	Fischer Custom Communications, Inc.	112	03/15/99
FCC-LISN-50-25-2	552	Power Mains Network (LISN), 50 $\mu$ H/250 $\mu$ H/50 $\Omega$ /0.25 $\mu$ F	Fischer Custom Communications, Inc.	113	03/26/99
9252-50-R-24-BNC	458	LISN, 50 $\mu$ H /250 $\mu$ H/50 $\Omega$ / 0.25 $\mu$ F	Solar Electronics Co.	941719	08/14/98
9252-50-R-24-BNC	457	LISN, 50 $\mu$ H /250 $\mu$ H/50 $\Omega$ / 0.25 $\mu$ F	Solar Electronics Co.	941720	01/04/99
ESHS 20	428	EMI Test Receiver	Rohde & Schwarz	837055/001	02/22/99
ESHS 30	459	EMI Test Receiver	Rohde & Schwarz	832354/004	02/22/99
CAT-20	599	20 dB Attenuator	Mini-Circuits	--	09/12/98
CAT-20	603	20 dB Attenuator	Mini-Circuits	--	09/12/98
CAT-20	608	20 dB Attenuator	Mini-Circuits	--	08/15/98
CAT-20	615	20 dB Attenuator	Mini-Circuits	--	09/12/98
CAT-20	602	20 dB Attenuator	Mini-Circuits	--	09/12/98
CAT-20	611	20 dB Attenuator	Mini-Circuits	--	09/12/98
CAT-20	600	20 dB Attenuator	Mini-Circuits	--	08/15/98

**Emissions Test Conditions: RADIATED EMISSIONS (Electric Field) (30 - 1000 MHz)**

<b>Model No.</b>	<b>Prop. #</b>	<b>Description</b>	<b>Manufacturer</b>	<b>Serial #</b>	<b>Cal Date</b>
NM-37/57A	420	OATS measurement set	Eaton/Ailtech	0561-09261	12/17/98
CCA-7	373	(Roof)		0773-03117	12/18/98
NM-37/57	171	OATS measurement set	Eaton/Ailtech	0709-82078	12/16/98
CCA-7	172	(Canyon)		0187-0322	12/17/98
3104	235	Antenna, Biconical	EMCO	3031	08/12/98
3110	451	Antenna, Biconical	EMCO	1378	09/26/98
3110B	491	Antenna, Biconical	EMCO	9508-2	04/08/99
3146	242	Antenna, Log Periodic Dipole	EMCO	1597	09/03/98
3146	243	Antenna, Log Periodic Dipole	EMCO	106X	09/26/98
3146	244	Antenna, Log Periodic Dipole	EMCO	1063	08/20/98
ESVS 30	427	EMI Test Receiver	Rohde & Schwarz	830350/006	02/12/99
ESVS 30	466	EMI Test Receiver	Rohde & Schwarz	833825/003	03/21/99

**Emissions Test Conditions: RADIATED EMISSIONS (Electric Field) (1 - 18 GHz)**

<b>Model No.</b>	<b>Prop. #</b>	<b>Description</b>	<b>Manufacturer</b>	<b>Serial #</b>	<b>Cal Date</b>
8566B	407	Spectrum Analyzer	Hewlett Packard	2311A02209	10/01/98
85662B	406	Spectrum Analyzer Display	Hewlett Packard	2309A04682	10/01/98
8566B	720	Spectrum Analyzer	Hewlett Packard	211500842	02/18/99
8566B	721	Spectrum Analyzer Display	Hewlett Packard	2112A02185	02/18/99
3115	453	Antenna, Double Ridge Guide	EMCO	9412-4363	09/01/98
3115	251	Antenna, Double Ridge Guide	EMCO	2495	08/98
ZJL-3G	649	Pre-Amplifier, 1 to 2 GHz	Minicircuits	--	01/23/99
AMF-5D-010180-35-10P	719	Pre-Amplifier, 1 to 18 GHz	Miteq, Inc.	549460	04/07/99
AFD3-0208-40-ST	367	Pre-Amplifier, 2 to 8 GHz	Miteq, Inc.	155382	10/21/98
AFS4-08001800-70-10P-4	368	Pre-Amplifier, 8 to 18 GHz	Miteq, Inc.	167	03/09/99
91888-2	252	Horn Antenna (1 to 2 GHz)	Eaton	101	10/31/98
91889-2	253	Horn Antenna (2 to 3.6 GHz)	Eaton	101	10/31/98
91892-1	254	Reflector Antenna (3.6 to 18 GHz)	Eaton	--	ncr
94613-1	255	Horn Antenna (3.6 to 7.6 GHz)	Eaton	--	10/31/98
91891-2	256	Horn Antenna (7.3 to 12 GHz)	Eaton	--	10/31/98
94614-1	257	Horn Antenna (12 to 18 GHz)	Eaton	--	10/31/98