

# OUTILLAGE DE MOULE MOLD TOOLING

POUR FABRICATION DE MOULE/ECHANTILLONS  
FOR PRODUCTION OF MOLD/SAMPLES ONLY

POIDS APPROXIMATIF (g) / APPROXIMATE WEIGHT (g) | TBD

ARTICLE / ITEM	MATERIEL / MATERIAL
Keyloop	AL DIE-CAST, GUNMETAL ANODIZING
Bottom Housing	ABS+PC, BLACK, TEXTURED
Function Button	ABS+PC, BLACK
Button Array	PC, REAR SIDE PRINTING
Gasket	SILICONE, TRANSL SHITE, BLACK PAINT, LASER ETCH
Top Housing	ABS+PC, BLACK, TEXTURED
Function Button Seal	SILICONE, BLACK
Cast Logo	AL DIE-CAST, GUNMETAL ANODIZING, BLACK PAINTED BACKGROUND
M1.4 x 6mm Pan Phillips TS	STEEL, ZN PLATED, BLACK COATING
Battery Insulator	PA66, BLACK
Vent	TYPE B WATERPROOF & SOUNDPROOF MEMBRANE

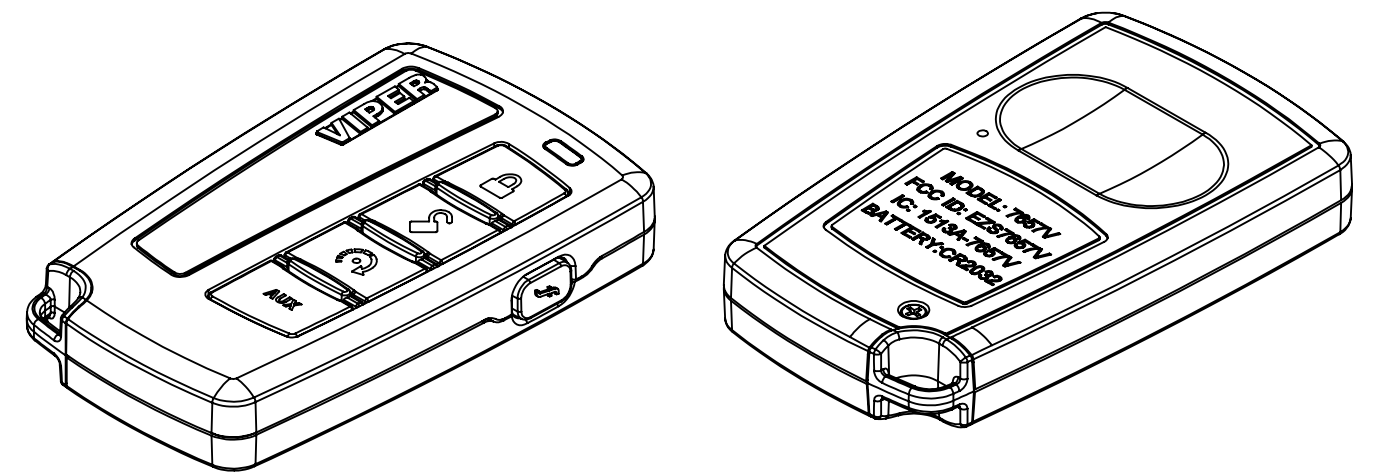
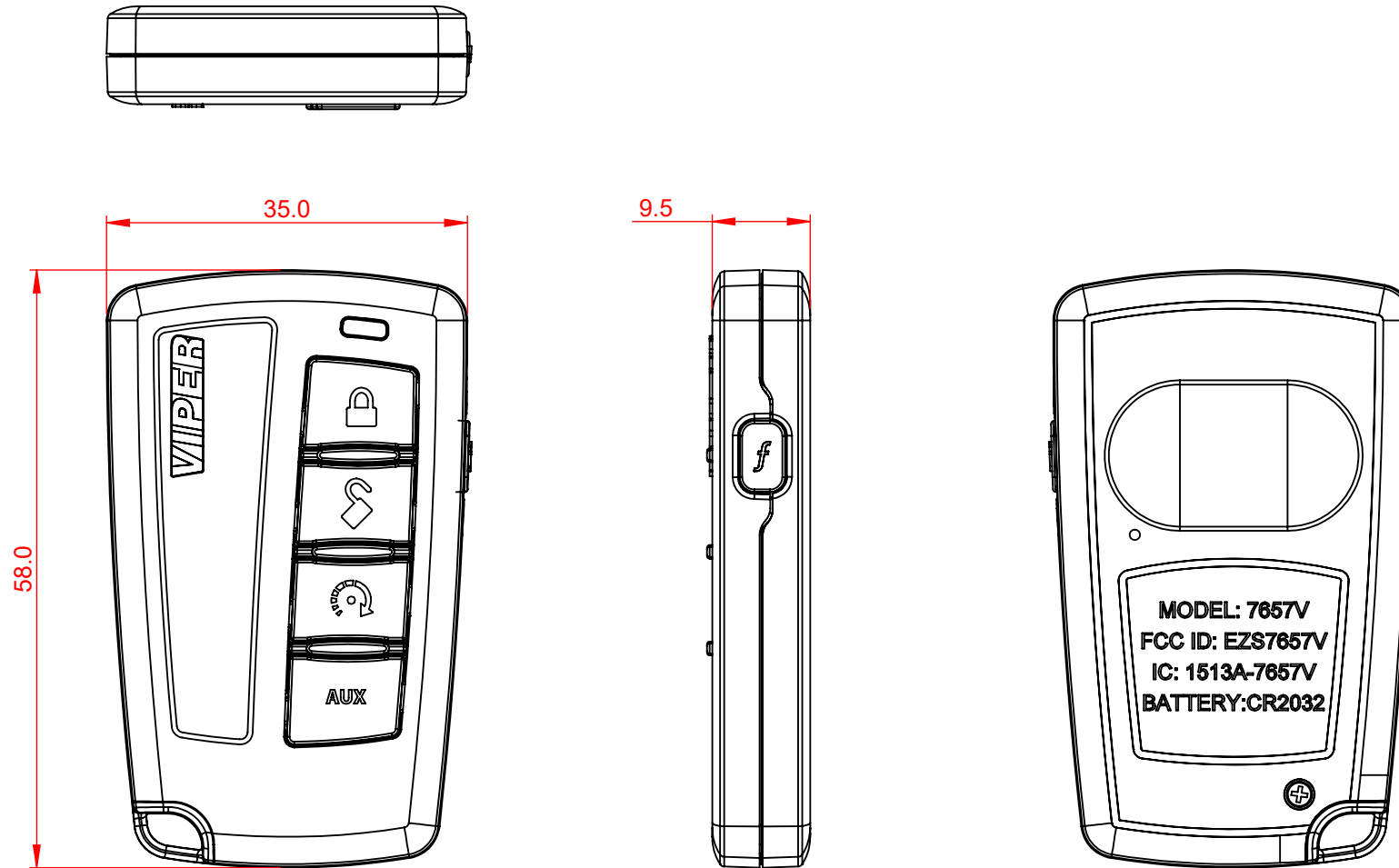

ECO	REV	DATE	DESCRIPTION	PAR / BY
	X12.0	24-10-09	TOOLING CANDIDATE - BOT HOUSING, FUNCTION BUTTON & FUNCTION BUTTON SEAL MODIFIED	M.M.
	X11.0	24-07-24	TOOLING CANDIDATE - BOT HOUSING & GASKET MODIFIED	M.M.
	X10.0	24-04-23	TOOLING CANDIDATE - FOR DFM REVIEW	M.M.
	X9.0	24-04-12	TOOLING CANDIDATE - FOR DFM REVIEW	A.T.

CONCEPTION DESIGN	A.T.	APPROBATION ADMIN. ADMIN. APPROVAL
-------------------	------	------------------------------------

### TOLERANCES

SAUF INDICATION CONTRAIRE  
UNLESS OTHERWISE NOTED

X mm	+/- 1 mm
X.X mm	+/- 0.5 mm
X.XX mm	+/- 0.10 mm



DIMENSIONS EN mm		CREE / CREATED
DIMENSIONS IN mm		2024-04-12

PRODUIT PRODUCT	7657V HHU		
ARTICLE ARTICLE	Layout		
DESSIN / DRAWING	REV	PAGE	
LDG-123-10215-01	X12.0	1 / 1	