



# **Cellular 500G Module Remote Installation Guide**

## Cellular 500G Module Remote Installation Guide

10 March 2021

815-0622-00

Copyright © 2021 Itron, Inc. All rights reserved.

### **Confidentiality Notice**

Confidential Information of Itron®, Inc., provided under nondisclosure obligations. The information contained herein is proprietary and confidential and is being provided subject to the condition that (i) it be held in confidence except to the extent required otherwise by law and (ii) it will be used only for the purposes described herein. Any third party that is given access to this information shall be similarly bound in writing.

### **Trademark Notice**

Itron is a registered trademark of Itron, Inc.

All other product names and logos in this documentation are used for identification purposes only and may be trademarks or registered trademarks of their respective companies.

For more information about Itron or Itron products, go to [www.itron.com](http://www.itron.com).

If you have questions or comments about a software or hardware product, contact Itron Technical Support Services.

### **Contact**

Email: [support@itron.com](mailto:support@itron.com)

Itron Access: <https://support.itron.com>

Telephone Itron Technical Support North America: 1-877-487-6602

For technical support contact information by region, go to [www.itron.com](http://www.itron.com) and select your country and language.

# Contents

- New in This Document** ..... **6**
- 1 Important Safety and Compliance Information** ..... **7**
  - U.S. and Canadian Patent Numbers ..... 7
    - U.S. Patent Numbers ..... 7
    - Canadian Patent Numbers ..... 7
  - USA, FCC Part 15 Spectrum Compliance ..... 7
    - USA, FCC Class B-Part 15 ..... 7
    - Modifications and Repairs ..... 8
  - Modifications, Repairs, Installation, and Removal ..... 8
  - Canada, ISED Spectrum Compliance ..... 9
  - RF Exposure (FCC/ISED) ..... 9
  - Transportation Classification ..... 9
  - Lithium Battery Safety ..... 9
  - Equipment Repairs ..... 10
  - Intrinsic Safety ..... 10
  - Electrostatic Ignition Hazard ..... 10
  - Module Cleaning ..... 10
  - Do Not Drop ..... 10
- 2 About the Itron Cellular 500G Remote Module** ..... **11**
  - Transmission Modes ..... 11
    - Mobile High Power Mode ..... 11
    - Mobile and Handheld Mode ..... 11
    - (Optional) Hard to Read Mode ..... 12
  - Gas Day Take ..... 12
  - High Flow Event/Alarm ..... 12
  - Local Auditing ..... 12
  - Low Battery Event/Alarm ..... 13
  - Cellular 500G Remote Module and Itron Security Manager ..... 13
  - Functional Specifications ..... 14

Operational Specifications .....	15
Device Firmware Functionality .....	15
Related Documents .....	15
<b>3 Mounting .....</b>	<b>16</b>
Standard Installation Options .....	16
Mounting on a Pipe .....	16
Completing the Installation .....	17
Adapter Plate Mounting Positions .....	19
Selecting and Installing On a Wall or Flat Vertical Mounting Location .....	19
<b>4 Programming .....</b>	<b>21</b>
Standard Configuration .....	21
Programming the Cellular 500G Module .....	21
Itron Programs and Software Variables .....	22
Field Deployment Manager (FDM) .....	22
Mercury X-Blank Options .....	24
Check Endpoint Functions .....	25
Field Collection System (FCS) (Mobile Mode Only) .....	25
OpenWay Collection Manager Center .....	25
Itron Enterprise Edition (IEE) Meter Data Management .....	25
<b>5 Specific Meter Manufacturer Installation .....</b>	<b>26</b>
Eagle Research Meter Installation .....	26
Eagle Research Installation Overview .....	26
Eagle Research Product Mounting Instructions .....	27
Eagle Research Mechanical and Wiring Installation Instructions .....	28
Eagle Research Corrector Programming and Requirements Notes .....	31
Elster American Meter Installation .....	34
Elster American Installation Overview .....	35
Elster American Meter Mounting Instructions .....	36
Elster American Mechanical and Wiring Installation Instructions .....	37
Galvanic Gas Micro Installation .....	40
Galvanic Installation Overview .....	40
Galvanic Product Mounting Instructions .....	40
Galvanic Mechanical and Wiring Installation Instructions .....	41
Programming the Galvanic Gas Micro Electronic Volume Corrector .....	41

GE Oil and Gas Meter Installation .....	41
GE Oil and Gas Module Installation Overview .....	42
GE Oil and Gas Custom Mounting Options .....	43
GE Oil and Gas Mechanical and Wiring Installation Instructions .....	46
GE Oil and Gas Meter Programming and Requirements Notes .....	53
Honeywell Instrument Installation .....	54
Honeywell Instrument Installation Overview .....	55
Honeywell Product Mounting Instructions .....	56
Honeywell Mechanical and Wiring Installation Instructions .....	57
Honeywell Instrument Programming and Requirements .....	62
Itron Meter Installation .....	65
National Meter Installation .....	66
Romet Meter Installation .....	67
Romet Installation Overview .....	67
Romet Product Mounting Instructions .....	68
Romet Mechanical and Wiring Installation Instructions .....	69
Romet Corrector Programming and Requirements Notes .....	75
Sensus Meter Installation .....	76
Sensus Meter Installation Overview .....	77
Sensus Product Mounting Instructions .....	77
Sensus Meter Mechanical and Wiring Installation Instructions .....	79
Sensus Meter Programming and Requirements Notes .....	79
<b>6 Diaphragm Meter Installation .....</b>	<b>80</b>
Diaphragm Meter Installation Overview .....	80
Module Mounting .....	82
Diaphragm Meter Mechanical and Wiring Installation Instructions .....	82
Programming and Requirements Notes for Diaphragm Meter Installations .....	88
Residential Module Programming Notes .....	88
Commercial Module Programming Notes .....	88
<b>7 Using Gel-cap Connectors to Complete Wiring Connections .....</b>	<b>89</b>
<b>8 Optional Sealant Application Instructions .....</b>	<b>91</b>

## New in This Document

Revision	Date	Description
REV 000	March 2021	First date of publication.

# 1

## Important Safety and Compliance Information

This section provides important information for your safety and product compliance.

### U.S. and Canadian Patent Numbers

#### U.S. Patent Numbers

- 4,614,945
- 4,753,169
- 4,768,903
- 4,799,059
- 4,867,700

#### Canadian Patent Numbers

- 1,254,949
- 1,267,936
- 1,282,118

### USA, FCC Part 15 Spectrum Compliance

This device complies with Part 15 of the FCC Rules. These limits are designed to provide reasonable protection against harmful interference in a residential installation.

Operation is subject to the following two conditions:

- This device may not cause harmful interference.
- This device must accept any interference that may cause undesirable operation.

This device must be installed to provide a separation distance of at least 20 centimeters (7.9 inches) from all persons to be compliant with regulatory RF exposure.

### USA, FCC Class B-Part 15

This equipment has been tested and found to comply with the limits for a Class B digital device, pursuant to Part 15 of the FCC Rules. These limits are designed to provide reasonable protection against harmful interference in a residential installation. This equipment generates, uses, and can radiate radio frequency energy and, if not installed and used in accordance with the instructions, may cause harmful interference to radio communications. However, there is no guarantee that interference will not occur in a particular installation. If this equipment does cause

harmful interference to radio or television reception, which can be determined by turning the equipment off and on, the user is encouraged to try to correct the interference by one or more of the following measures:

- Reorient or relocate the receiving antenna.
- Increase the separation between the equipment and receiver.
- Connect the equipment into an outlet on a circuit different from that to which the receiver is connected.
- Consult the dealer or an experienced radio or TV technician for help.

## Modifications and Repairs

To ensure system performance, this device and antenna shall not be changed or modified without the express approval of Itron. Per FCC and ISED rules, unapproved modifications or operation beyond or in conflict with these instructions for use could void the user's authority to operate the equipment.

## Modifications, Repairs, Installation, and Removal

To ensure system performance, this device and antenna shall not be changed or modified without the express approval of Itron. Any unauthorized modification will void the user's authority to operate the equipment, per FCC and ISED rules.

In the event of malfunction, all repairs should be performed by Itron. It is the responsibility of users requiring service to report the need for service to Itron.



## Canada, ISED Spectrum Compliance

### Compliance Statement Canada

This device complies with Innovation, Science and Economic Development Canada (ISED) license-exempt RSS standard(s). Operation is subject to the following two conditions: (1) this device may not cause interference, (2) this device must accept any interference, including interference that may cause undesired operation of the device.

Under Innovation, Science and Economic Development Canada (ISED) regulations, this radio transmitter may only operate using an antenna of a type and maximum (or lesser) gain approved for the transmitter by Industry Canada. To reduce potential radio interference to other users, the antenna type and its gain should be so chosen that the equivalent isotropically radiated power (e.i.r.p.) is not more than that necessary for successful communication.

### Déclaration de Conformité

Le présent appareil est conforme aux CNR d'Industrie Canada applicables aux appareils radio exempts de licence. L'exploitation est autorisée aux deux conditions suivantes: (1) l'appareil ne doit pas produire de brouillage, (2) l'utilisateur de l'appareil doit accepter tout brouillage radioélectrique subi, même si le brouillage est susceptible d'en compromettre le fonctionnement.

Conformément à la réglementation d'Industrie Canada, le présent émetteur radio peut fonctionner avec une antenne d'un type et d'un gain maximal (ou inférieur) approuvé pour l'émetteur par Industrie Canada. Dans le but de réduire les risques de brouillage radioélectrique à l'intention des autres utilisateurs, il faut choisir le type d'antenne et son gain de sorte que la puissance isotrope rayonnée équivalente (p.i.r.e.) ne dépasse pas l'intensité nécessaire à l'établissement d'une communication satisfaisante.

## RF Exposure (FCC/ISED)

This equipment complies with radiation exposure limits set forth for an uncontrolled environment. This equipment should be installed and operated with minimum distance 20 cm between the radiator and your body. This transmitter must not be co-located or operating in conjunction with any other antenna or transmitter.

Cet équipement est conforme aux limites d'exposition aux radiations dans un environnement non contrôlé. Cet équipement doit être installé et utilisé à distance minimum de 20 cm entre le radiateur et votre corps. Cet émetteur ne doit pas être co-localisées ou opérant en conjonction avec tout autre antenne ou transmetteur.

## Transportation Classification

The Federal Aviation Administration prohibits operating transmitters and receivers on all commercial aircraft. When powered, the Itron device is considered an operating transmitter and receiver and cannot be shipped by air. All product returns must be shipped by ground transportation.

## Lithium Battery Safety



**Warning!** Follow these procedures to avoid injury to yourself or others:

- The lithium battery may cause a fire or chemical burn if it is not disposed of properly.
- Do not recharge, disassemble, heat above 100° Celsius (212° Fahrenheit), crush, expose to water, or incinerate the lithium battery.
- Keep the lithium battery away from children.
- Fire, explosion, and severe burn hazards

## Equipment Repairs



**Warning!** Only authorized Itron personnel should attempt repairs on Itron equipment. Attempts to do so by others might void any maintenance contract with your company. Unauthorized service personnel might also be subject to shock hazard on some Itron equipment if removal of protective covers is attempted.

## Intrinsic Safety



**Warning!** Substitution of components may impair intrinsic safety.

## Electrostatic Ignition Hazard



**Warning!** Verify the area is not hazardous when installing, servicing, cleaning, or touching the Itron device.

## Module Cleaning



**Warning!** Clean only with a damp cloth.

## Do Not Drop



**Warning!** While Itron modules are designed to withstand a drop, dropping the module may damage the device and void the warranty.

# 2

## About the Itron Cellular 500G Remote Module

The Cellular 500G remote modules are an IPV4/IPv6 open standards-based gas modules designed to be read under Itron's multi-purpose OpenWay Riva Network Mode or by legacy Mobile Mode. In OpenWay Riva Network Mode, the Remote module offers firmware download, sub-hourly interval data, and extended data storage. In Mobile Mode, the Remote module operates identical to the 100G DLS Dataglogging Remote module. Itron Remote modules can be read by legacy handhelds and mobile or the new Itron Mobile Radio readers. The Remote module continues Itron's tradition of reliability, accuracy, and long battery life while supporting the industry's standards for security and intrinsic safety.

The remote module features tilt and cut cable-event reporting and security seals to indicate physical tampering and minimize theft. Cut cable is reported when communications fail between the meter or instrument and the Remote module, possibly from a cut or disconnected cable. The Remote module circuitry senses an electrical current break to report a cut cable alarm or event.

### Transmission Modes

In OpenWay Riva Network Mode, the module provides 3,840 buckets of configurable interval data. Interval options are 5, 15, 30, or 60 minutes.

**Note:** Interval data options are dependent on the module's firmware version. For more information, see [Device Firmware Functionality on page 15](#).

Output power in OpenWay Riva Network Mode is designed to transmit 3 times a day with a 20-year battery life.

In Mobile Mode, the module provides 960 buckets of hourly interval data and can be set to transmit in mobile and handheld, hard to read mobile and handheld. Mobile Mode transmission modes include the following transmission characteristics:

#### Mobile High Power Mode

The module transmits a high-powered RF message every 60 seconds. In Mobile High Power Mode, the expected battery life is 20 years.

#### Mobile and Handheld Mode

The module transmits a medium-powered RF message every 15 seconds. In Mobile and Handheld Mode, the expected battery life is 20 years.

## (Optional) Hard to Read Mode

The module transmits a high-powered RF message every 30 seconds. In Hard to Read Mode, the expected battery life decreases to 15 years in this mode. The *hard to read mobile mode* should only be used for exceptionally hard-to-read applications (such as meters installed on rooftops or in sub-basements).



**Caution:** If you perform a Switch to OpenWay Riva Network Mode or Switch to Mobile Mode operation, it results in a loss of interval data.

An FCC license is not required to read the modules.

## Gas Day Take

**Note:** Gas Day Take functionality is dependent on the Cellular 500G Remote module firmware version. For more information, see [Device Firmware Functionality on page 15](#).

Gas Day Take (GDT) is critical to many natural gas utilities. GDT allows utilities to manage deregulated gas purchases. While daily GDT reads can be used for various operations within the utility, the primary time constrained business operation is to daily balance deregulated (transport) customers. GDT requires GDT data from a percentage (typically a maximum of 10%) of the utility's customers at 9:00 a.m. Central Clock Time.

All collected data must be prepared and presented to deregulated marketers and customers by 11:00 a.m. CCT to support the gas utility's deregulated tariff. If a deregulated marketer of customer under or over-burns what they nominated for a given day, they may pay a daily penalty. Customers require the previous day's GDT data to make adjustments to their next day nomination to avoid penalties.

## High Flow Event/Alarm

**Note:** High Flow event functionality is dependent on the module's firmware version. For more information, see [Device Firmware Functionality on page 15](#).

High Flow is a configurable event/alarm that can alert a utility of an excessive flow of gas to avoid potential hazardous events. The High Flow threshold can be configured using FDM Tools for the OWCM for OpenWay Riva modules.

## Local Auditing

**Note:** Local auditing functionality is dependent on the module's firmware version. For more information, see [Device Firmware Functionality on page 15](#).

The Itron Cellular 500G Remote Module supports local data auditing of installation programming. Local auditing features the listed characteristics.

- Supports writing data (in both manufacturing and by FDM) to the module to support future installation programming auditing.
- Reading the auditing data is supported locally.
- Auditing parameters include FDM User ID, number of dials, meter drive rate, unit of measure, count rate, rollover, and PComp.
- Timestamping of auditing parameters.
- Log access via COSEM only.

## Low Battery Event/Alarm

**Note:** For Cellular 500G Remote Modules, low-battery functionality is dependent on the module's firmware version. For more information, see [Device Firmware Functionality on page 15](#).

The OpenWay Riva Cellular 500G Remote Modules' low-battery events are flagged when the device reaches a 10% of battery life remaining state. The event triggers an alarm configurable for asynchronous delivery to the head end system.

## Cellular 500G Remote Module and Itron Security Manager

The Cellular 500G remote module is a component of Itron's OpenWay Riva system. The module's system security, provided by Itron Security Manager (ISM), applies to the RF communications between the collection device and the module.

There are two fundamental security processes used in the Itron Security Manager to ensure system communication confidentiality and validity.

- **Authentication.** Authentication is the process of confirming that an artifact is genuine or valid. Authentication in the module is the process of verifying a request is from a valid source and in its original form.
- **Encryption.** Encryption is the process of transforming information to make it unreadable to anyone who does not have a valid security key. There are two types of encryption, symmetric and asymmetric. Symmetric encryption uses a shared key to decrypt or encrypt information. Asymmetric encryption uses a private key to encrypt and a public key to decrypt. Data transmissions over the network are protected using AES-256 encryption.

As a component of the Itron OpenWay Riva solution, the module supports the security model found in the OpenWay solution for both reading and programming. If the modules are shipped without security enabled (ready to secure), the utility can—at a later date—configure the modules for ISM enhanced security.



**Important!** Modules ordered pre-programmed with security injected and specified as Zero Touch Deployment require that the installer rotates the wriggler five (5) times to activate the module to join the network, if the module is installed in a location with little or no gas flow.

## Functional Specifications

Functional specification	Description
<b>Power source</b>	Single "D" cell lithium batteries
<b>Tamper detection</b>	Tilt and cut cable
<b>Regulatory and Standards</b>	<p>FCC compliance: Part 15.247, 15.249 (programming)</p> <p>FCC IDs:</p> <ul style="list-style-type: none"> <li>■ EWQ500GA: American/Rockwell</li> <li>■ EWQ500GB: Sprague/Itron</li> <li>■ EWQ500GC: Commercial</li> <li>■ EWQ500GR: Remote</li> </ul> <p>ISED compliance: RSS-247, RSS-210 (programming)</p> <p>IC:</p> <ul style="list-style-type: none"> <li>■ 864D-500GA: American/Rockwell</li> <li>■ 864D-500GB: Sprague/Itron</li> <li>■ 864D-500GC: Commercial</li> <li>■ 864D-500GR: Remote</li> </ul> <p>Measurement Canada: Pending</p>
<b>Intrinsically safe per</b>	Telemetry Equipment for use in Hazardous Locations, for Cl I, Div 1, Gp D for Haz Loc, Temp Code T1, $-40^{\circ}\text{C} \leq T_a \leq +70^{\circ}\text{C}$ .
<b>Operational</b>	<p>All 500G modules operate without the need for an FCC or ISED license.</p> <p>Frequency: 902 to 928 MHz ISM band</p> <p>Program frequency: 908 MHz</p>
<b>Australia</b>	<p>ACMA AS/NZS 4268</p> <p>Frequency: 915 to 928 MHz ISM band</p> <p>Program frequency: 916 to 926.8 MHz</p>
<b>Product identification</b>	Numeric and bar coded type and serial number
<b>Construction materials</b>	Gray polycarbonate housing and back plate with encapsulated electronics

## Operational Specifications

Operational specifications	Description
Operating temperatures	-40° to 158° F (-40° to +70° C)
Operating humidity	5 to 95 percent relative humidity
Data integrity	Verified in every data message

## Device Firmware Functionality

This section lists the remote module device firmware information and lists functionality by version.

Part Number	Global Software Release (GSR) Version	FDM Check Endpoint Firmware Version	Over-the-Air Firmware Part Number	Firmware Functionality
FMW- xxxx- xxx1601- 004 [4.4.2]	4.15.4	1.3.74.4.0	DFW-xxx-xxx	<ul style="list-style-type: none"> <li>■ Initial firmware release</li> <li>■ IPv6 Adressable</li> <li>■ Network Mode</li> <li>■ Mobile Mode</li> <li>■ 60-minute interval data</li> </ul>

## Related Documents

- *OpenWay Collection Manager Operational Guidelines*
- *OpenWay Riva Collection Manager Device Interface Guide*
- *Gas and Telemetry Module Meter Compatibility List*
- *OpenWay Riva Gas Devices Ordering Guide*
- *Cellular 500G Module Specification Sheet*
- *Field Deployment Manager Tools Mobile Application Guide*
- *Field Deployment Manager Tools Configuration Guide*
- *Field Deployment Manager Field Representative Guide*

# 3 Mounting

This chapter provides the instructions to mount the remote module on a pipe or other flat vertical surface (wall).

## Standard Installation Options

Mount the remote module using the pipe mount or wall mount (flat vertical surface) procedure.

- **Pipe mount.** Itron offers a pipe installation kit (CFG-0005-003) to mount the remote module on a pipe.
- **Flat vertical (wall) mount.** Installation using the wall mount option places the module on a wall or other vertical surface.

Select the mounting option that will best work for your system. For example, your setup may provide the location for a pipe mount but not a wall mount. The preferred mounting location is near the meter or instrument, but some installations may require an extended cable length. For example, your installation may require mounting the module around a corner to avoid RF interference. The remote module supports cable lengths up to 300 feet with a recommended one-splice limitation. Installers must mount the remote module in a vertical position with the label directional arrow pointed upward.



**Warning!** Do not mount the remote module in an orientation other than vertical (remote module label arrow pointed upward). Violating the mounting orientation requirements may void the product warranty.



Upright vertical positioning is critical because:

- The modules are optimized for communication and require upright mounting. Any other mounting position could result in reduced RF performance.
- The remote module tilt tamper sensor requires upright mounting. Any other mounting position can cause issues with the module's tilt tamper detection.



## Mounting on a Pipe





The following items are required to mount the remote module on a pipe.



Itron part number	Description
<p>CFG-0005-003</p> 	<p>Pipe mount kit contents:</p> <ul style="list-style-type: none"> <li>■ 2 band clamps</li> <li>■ 2 tamper seals</li> <li>■ 1 pipe bracket</li> <li>■ 2 cable ties</li> <li>■ 1 adapter plate</li> <li>■ the following screws:</li> </ul>  <ol style="list-style-type: none"> <li>1. SCR-0215-001 (2) #8-16 x ½ inch slotted pan-head tapping screw, corrosion-resistant steel. Attaches the adapter plate to the pipe bracket.</li> <li>2. SCR-0215-002 (2) #8-16 1-inch slotted pan-head tapping screw, corrosion-resistant steel. Attaches the module to the adapter plate.</li> </ol>

## Completing the Installation

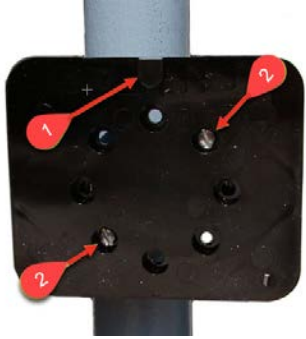

<p>1. Remove the pipe bracket and clamp from the kit.</p>	
<p>2. Loosen the band clamp screw until the end of the band releases.</p>	
<p>3. Push the end of the clamp's band through the holes in the pipe bracket as shown.</p>	

<p>4. Place the band clamp around the pipe. The band will loosely wrap around the pipe.</p> <ol style="list-style-type: none"> <li>Push the end of the band through the band clamp screw assembly.</li> <li>Turn the band clamp's screw assembly to fit into the pipe bracket opening.</li> <li>Tighten the clamp screw until the band clamp is secure on the pipe.</li> </ol>	
<p>5. Place the adapter plate on the pipe bracket with the mounting lug at the top. The adapter plate screw bosses fit into the pipe bracket recess.</p>	
<p>6. Ensure that the adapter plate is positioned as shown with the mounting lug (1) at the top.</p> <ol style="list-style-type: none"> <li>Install the adapter plate on the pipe mounting bracket, use the two shortest (1/2-inch) screws from the pipe mount kit.</li> <li>Place the mounting screws into the holes as shown (2).</li> </ol> <p>Tighten both screws in an alternating pattern to 9 to 12 inch-pounds torque.</p>	
<p>7. Position the back of the remote module against the face of the adapter plate. The adapter plate mounting lug must be positioned above the module mounting lug recess.</p>	
<p>8. Push up on the module until the adapter plate mounting lug is as far as possible inside the module mounting lug recess.</p>	
<p>9. Align the module back-plate mounting holes with the pipe mount adapter plate holes. Install the two one-inch module mounting screws from the installation kit. Tighten the module mounting screws evenly in an alternating pattern. Tighten the screws to 9 to 12 inch-pounds torque.</p>	

<p>10. Insert the tamper seals.</p>	
<p>11. Gather the excess module cabling into a loop and use the cable tie to secure the gathered cable to the pipe.</p>	

## Adapter Plate Mounting Positions

**Note:** The notch at the top of the adapter plate (1) must always be at the top position. The following illustrations show the various mounting configurations. The adapter plate mounting screw locations are indicated (2).

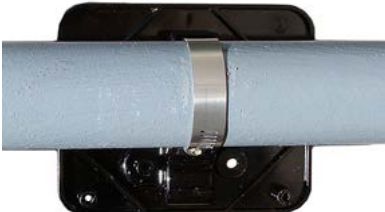
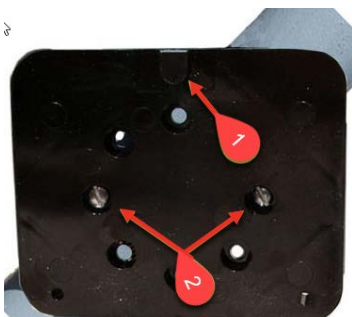
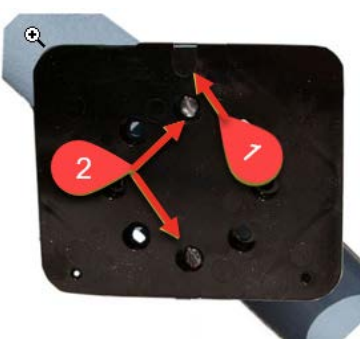
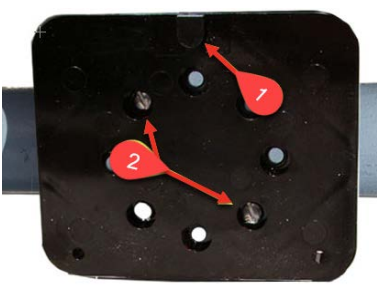
45-degree angle with the pipe running to the right	45-degree angle with the pipe running to the left	Horizontal
		
		

## Selecting and Installing On a Wall or Flat Vertical Mounting Location

Carefully select a mounting location free from electrical wires. The mounting location must have the proper clearance to accommodate the 1-1/2-inch module mounting screws so nothing is damaged by the drill or mounting screws. Use a compatible mounting screw.

1. Drill three pilot holes in the mounting surface. The drilled pilot holes for the two bottom screws must be on a horizontal line.

- a. 3 inches
- b. 1-11/16 inches
- c. 3-3/8 inches

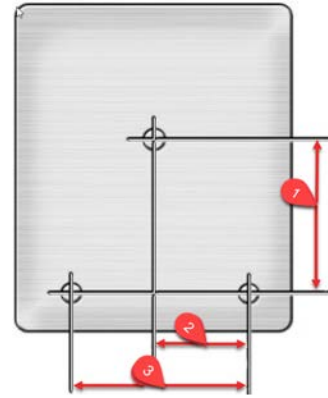

2. Screw the top mounting screw into the top pilot hole drilled in step one, leaving enough of the screw protruding so the module lug recess on the back plate slides over the screw head and fits completely into the lug recess. Make adjustments as necessary.

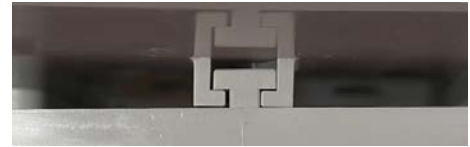

3. Install the two bottom mounting screws. Tighten the screws in an alternating pattern to secure the module firmly in position.

4. Place a new tamper seal over each bottom module mounting screw as required.



**Note:** To reduce the risk of cable damage, secure any excess module cabling with a cable tie.



# 4 Programming



**Caution:** You must program the module before use.

Programming Itron modules requires an understanding of:

- Your meter's drive rate and the number of dials
  - The drive rate and number of dials is important for programming the module to count correctly and roll over to zero at the correct time. For example, a four-dial, 2 cubic-foot meter configuration will count two cubic-feet for each rotation and roll over to zero after 9999.99 where the **ones place** is equivalent to 100 cubic-feet.
- How your system interprets the meter reading
  - Some systems modify the consumption reading with the collection software. Other times, the billing system is used to make modifications. If modifications are made in both systems, issues may cause consumption reading errors.

It is important to understand your system before the modules are programmed.

Program the module in OpenWay Riva Network Mode using a compatible programming device loaded with FDM version 4.1 or higher.

Program the module in Mobile Mode using an approved programming device loaded with Field Deployment Manager (FDM) software version 4.0 or higher.

## Standard Configuration

Gas modules are capable of configurations that reduce battery life. Standard battery life is based on the following configuration:

- Hourly interval data
- Interrogations of 3 times per day
- 60-second receiver wakeup
- Five firmware downloads over the life of the module
- Network management and security overhead set to default timing
- RF at capacity (2,000 maximum per cell)
- Average of one two-way command/response per week

## Programming the Cellular 500G Module

Program the meter drive rate into the remote module using a compatible programming device.

1. Verify that you have the correct programming mode (OpenWay Riva Network Mode or Mobile Mode [mobile high power mode, mobile/handheld mode, or hard-to-read mode]) for your application.
2. For all programming and **Check Endpoint** operations using a handheld computer, hold the handheld as close to vertical as possible. For best success, keep the handheld within six feet of the target module.
3. Programming parameters are based on the configuration file loaded into the programming device.
4. **Read** or **Check** the remote module using a compatible handheld computer.
  - If the read result is higher than the number programmed in step 1, the module is counting correctly.
  - If the read result is not higher than the number programmed in step 1, replace the remote module.

## Itron Programs and Software Variables

This section defines and clarifies possible system variables you may encounter in programming modules.

### Field Deployment Manager (FDM)

The following tables illustrate various FDM programming configurations and the endpoint response to each setting.

	1,000,000,000,000 CF	100,000,000,000 CF	10,000,000,000 CF	1,000,000,000 CF	100,000,000 CF	10,000,000 CF	1,000,000 CF	100,000 CF	10,000 CF	1,000 CF	100 CF	10 CF	1 CF
3 Dial, 1 cubic foot													1
3 Dial, 2 cubic feet													2
4 Dial, 1 cubic foot													1
4 Dial, 2 cubic feet													2
4 Dial, 5 cubic feet													5
4 Dial, 10 cubic feet												1	
5 Dial, 1 cubic foot													1
5 Dial, 2 cubic feet													2
5 Dial, 5 cubic feet													5
5 Dial, 10 cubic feet												1	
5 Dial, 20 cubic feet												2	
5 Dial, 25 cubic feet												2	5
5 Dial, 40 cubic feet												4	
5 Dial, 50 cubic feet												5	
5 Dial, 100 cubic feet											1		
5 Dial, 500 cubic feet											5		
5 Dial, 1000 cubic feet									1				
6 Dial, 5 cubic feet													5
6 Dial, 10 cubic feet												1	
6 Dial, 20 cubic feet												2	
6 Dial, 50 cubic feet (CCF)												5	
6 Dial, 50 cubic feet (MCF)												5	
6 Dial, 100 cubic feet (CCF)											1		
6 Dial, 100 cubic feet (MCF)											1		
6 Dial, 500 cubic feet (CCF)											5		
6 Dial, 500 cubic feet (MCF)											5		
6 Dial, 1000 cubic feet (CCF)										1			
6 Dial, 1000 cubic feet (MCF)										1			
6 Dial, 10000 cubic feet									1				
7 Dial, 100 cubic feet (CCF)											1		
7 Dial, 100 cubic feet (MCF)											1		
7 Dial, 1000 cubic feet (CCF)										1			
7 Dial, 1000 cubic feet (MCF)										1			

<b>Numbers represent the place and value that will increment per count/pulse</b>
<b>Entered in initial index read</b>
<b>Entered in initial index read but will not increment</b>
<b>Not entered in initial index read but passed on in reading</b>
<b>Not entered in initial index read and will not increment; will always read 0</b>
<b>Internal, incrementing digits not visible or transmitted</b>
<b>Not in SCM or SCM Plus but read out in NIM. Rolls over after 32 bits 4,294,967,295</b>

	100,000,000 M <sup>3</sup>	10,000,000 M <sup>3</sup>	1,000,000 M <sup>3</sup>	100,000 M <sup>3</sup>	10,000 M <sup>3</sup>	1,000 M <sup>3</sup>	100 M <sup>3</sup>	10 M <sup>3</sup>	M <sup>3</sup>	0.1 M <sup>3</sup>	0.01 M <sup>3</sup>
5 Dial, 0.05 cubic meter											5
6 Dial, 0.10 cubic meter											1
6 Dial, 1 cubic meter									1		
6 Dial, 10 cubic meters								1			
6 Dial, 100 cubic meters							1				
7 Dial, 10 cubic meters								1			
7 Dial, 100 cubic meters							1				

### Programming Example

Endpoint programmed for 6 dial, 1000 cubic feet CCF.

1. Enter the initial index read. For this example, the initial read is 123456 where 6 = 600 cubic feet. After the initial programming, an endpoint read will result in a reading of 1234560 where the least significant digit is in 10's of cubic feet. Since counting is with a drive rate of 1000 cubic feet and the reading is transmitted in 10's of cubic feet, the last two digits of the reading will not change.
2. Program the endpoint to 123456.
3. Read the endpoint. The result should be 1234560 with the zero added to put the reading in 10's of cubic feet.
4. Add one count. The result should be 12346**60**. Notice that the last two digits of **60** do not change.

	1,000,000,000 CF	100,000,000 CF	10,000,000 CF	1,000,000 CF	100,000 CF	10,000 CF	1,000 CF	100 CF	10 CF
6 Dial, 1000 cubic feet (CCF)							1		

### Mercury X-Blank Options

Endpoints (modules) can be programmed with one of the Mercury X-Blank options. There are 1, 2, 3, and 4 blank option available. Blank options are set up as a *what-you-see-is-what-you-get* (WYSIWYG) configuration. The values are not set in cubic feet or cubic meter standards. The Mercury X-Blank options are used in configurations where the system receives pulses from a corrector or instrument that can change pulse values and has configurable display digits. The Mercury-X Blank options allow users to program the endpoint to match the configuration of the corrector or instrument.



## Check Endpoint Functions

The FDM Check Endpoint function triggers users to input the number of dials and drive rate if a Check Endpoint is requested for an endpoint programmed for 5, 6, or 7-dial meter configurations. The request to input the dial and drive rate information happens only if the system has more than one option using the same count rate and rollover variable enabled in their FDM business unit.

**Note:** Itron recommends that users only enable the configurations used by your business unit. Having only one meter configuration option enabled (with the endpoint variable being checked in the FDM business unit) eliminates the need to enter the number of dials.

## Field Collection System (FCS) (Mobile Mode Only)

**Note:** This section applies only to devices running on the OpenWay Riva network.

In FCS, a Read Type Code can be assigned to a meter session. The Read Type Code in conjunction with the Endpoint Type is used to determine how the endpoint reading is formatted using the Endpoint Translation table in FCS. The Endpoint Translation table is a configurable table that is used to determine the truncation factor and multiplier for each reading. A default Endpoint Translation is defined for each type of endpoint supported by FCS (ReadType of 00 for each EndpointType). If the default Endpoint Translation is not formatting the read correctly, an additional Endpoint Translation can be defined to properly format the read.

Since the Endpoint Translation Code is based on the Read Type Code and the Endpoint Type, changing from a 40-series endpoint to a 100-series endpoint can cause the reading to be truncated differently. If you are having issues with your reading after a change out, check your Read Type Codes and Endpoint Translation Codes.

## OpenWay Collection Manager Center

**Note:** This section applies only to devices running on the OpenWay Riva network.

The OpenWay Operation Center (OWOC) collects the raw reading and passes it on without making any formatting changes.

## Itron Enterprise Edition (IEE) Meter Data Management

**Note:** This section applies only to devices running on the OpenWay Riva network.

The standard unit of measure (UOM) in IEE is cubic feet for gas endpoints. The reading passed on by the gas endpoint is not in cubic feet if endpoints with 6 and 7-dial meter configurations are programmed, so adjustments are required to set the correct unit of measure. If you are having issues with your readings in IEE but your endpoint and meter index match, check your unit of measure within IEE.



# 5

## Specific Meter Manufacturer Installation

This chapter provides the instructions to install the remote module to compatible meters. Reference each section for compatible meters.

### Eagle Research Meter Installation

This section provides the information to install the 500G remote module on the following compatible Eagle Research correctors.

Meter model	Meter notes	Itron part number	module notes
 <b>MPplus volume corrector</b>	Pulse width: 70mS and 500mS off timing Pulse output board required	ERG-7000-502	
 <b>XARTU-1</b> <b>volume corrector</b>	Pulse width: 70mS on and 500mS off timing Corrector must have Solid State relays		

### Eagle Research Installation Overview

Installing the remote module to an Eagle Research volume corrector involves four tasks.

1. Programming or verifying that the volume corrector is set up to work with the remote module.  
Programming requires a computer loaded with the Eagle Research Software and an Eagle Research computer-to-volume corrector communication cable.
2. Connecting the module to the volume corrector.  
Requires a wire stripper and flat-tip screwdriver sized to tighten the terminal connections on the Eagle corrector.

3. Mounting the remote module. Select the mounting option appropriate for your installation. Mounting options include:
  - Wall mount on a sheet metal surface
  - Pipe mount using the Itron pipe mount kit CFG-0005-003
  - Custom Eagle Research mounting option using the Eagle research mounting rail (Eagle Research part number 1010247).

**Note:** Itron recommends an optional sealant for installations where insect intrusion may be a problem. For more information, see [Optional Sealant Application Instructions on page 1](#).

4. Programming the remote module. Programming requires an Itron programming device (for example, an FC300SR). For programming information, see [Programming on page 21](#).

Remote module configuration with the meter is dependent on your system application. See the Eagle Research meter product documentation for the Eagle Research Field Manager database configuration information.

This mounting information describes installation for two remote modules—one for corrected reads and one for uncorrected reads. Installation is the same for both configurations (corrected or uncorrected). Eagle Research meter outputs are optically isolated from the meter control board and from each other. The volume corrector software configuration controls the port operation. Follow the Eagle Research documentation and these Itron instructions to ensure the correct compatibility and installation.



## Eagle Research Product Mounting Instructions

**Note:** These instructions show the Eagle Research MPplus volume corrector. Installation is the same for the XARTU-1 corrector.

1. Mount a remote module on each end of the mounting rail using the mounting screws supplied with the modules.

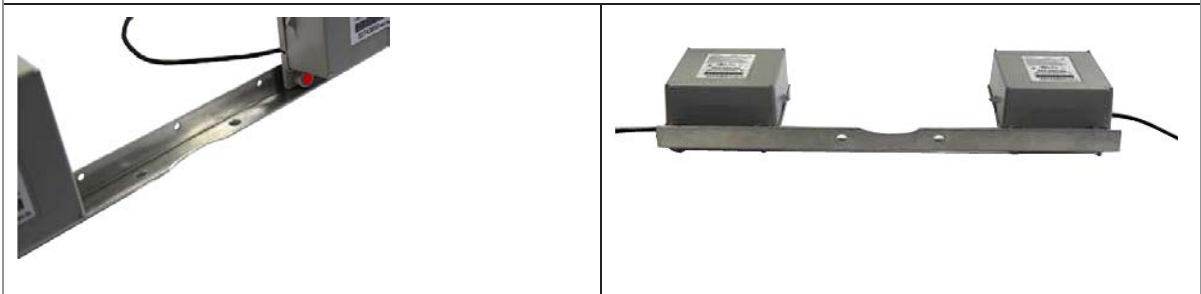
**Note:** The notch in the mounting rail is the front bottom of the rail. The modules mount to the back of the mounting rail.





<p>2. Insert tamper seals into the tamper seal mounting cups on the remote modules.</p>	
<p>3. With the corrector facing forward, align the corrector mounting holes with the index drive mounting holes.</p>	
<p>4. Insert the corrector's mounting screws in the front corrector and index mounting holes. Loosely tighten the front two mounting screws.</p>	
<p>5. Align the inside mounting rail screw holes over the back index and corrector mounting screw holes.</p>	
<p>6. Insert the two remaining mounting screws in the corrector bracket mounting holes.</p>	
<p>7. Tighten all four mounting screws.</p>	

## Eagle Research Mechanical and Wiring Installation Instructions

This section provides wiring and connection information for compatible Eagle Research products. Refer to the instruction for your product type.

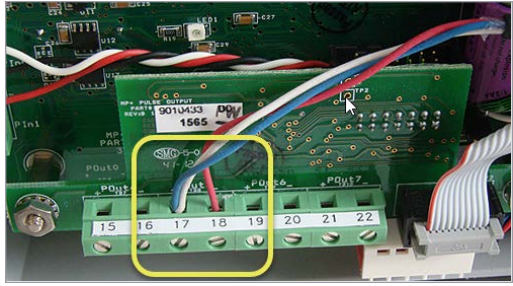

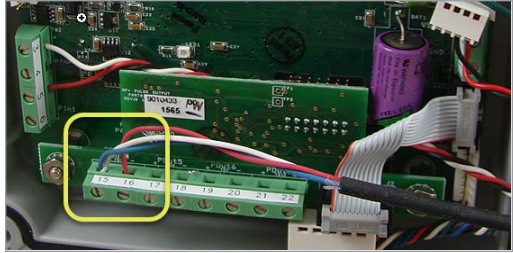
### Connecting to the MPplus Corrector

<p>1. With the MPplus door open, insert the flying leads from the remote module into the compression connector on the left of the MPplus housing.</p>	
<p>2. Pull the lead wires through the compression connector until there is adequate wire to reach the terminal blocks labeled 15, 16, 17, 18, 19, 20, 21, and 22.</p>	
<p>3. Tighten the compression connector.</p>	
<p>4. Twist the remote module's blue and white wires together.</p>	
<p><b>For uncorrected reads:</b></p>	
<p>5. Connect:</p> <ul style="list-style-type: none"> <li>■ the twisted blue and white wires to terminal 17 on the MPplus terminal block.</li> <li>■ the red remote module wire to terminal 18 on the MPplus terminal block.</li> </ul>	

<b>For corrected reads:</b>	
6. Connect the twisted blue and white wires to terminal 15 on the MPplus terminal block.	
7. Connect the red remote module wire to terminal 16 on the MPplus terminal block.	
8. Close and latch the MPplus corrector door.	

## Connecting to the XARTU Corrector

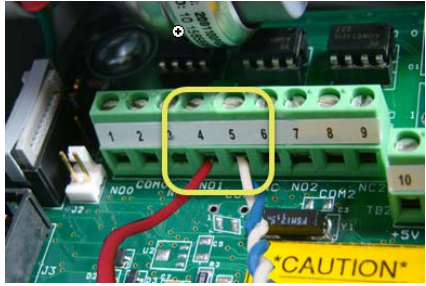
<b>For XARTU-1 uncorrected reads:</b>	
1. Insert the flying leads from the remote module into the compression connector on the right of the XARTU-1 corrector housing.	
2. Pull the lead wires through the compression connector until there is adequate wire to reach the K2 terminal port.	
3. Tighten the compression connector.	

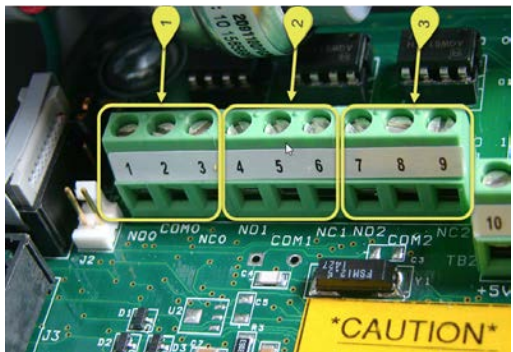
<p>4. Connect the red remote module wire to pin 4 of the K2 terminal port.</p>	
<p>5. Twist the remote module's blue and white wires together and connect the twisted blue and white wires to pin 5 of the K2 terminal port.</p>	
<p>6. Plug the MTA battery connector from the battery pack into the VBAT1 connector to supply power to the XARTU-1 corrector.</p>	
<p>7. Close and latch the corrector door.</p>	
<p><b>For XARTU-1 corrected reads:</b></p>	
<p>8. With the XARTU door open, insert the flying leads from the remote module into the compression connector on the left of the corrector's housing.</p>	
<p>9. Pull the lead wires through the compression connector until there is adequate wire to reach the K1 terminal port.</p> <ol style="list-style-type: none"> <li>K1</li> <li>K2</li> <li>K3</li> </ol>	
<p>10. Tighten the compression connector.</p>	
<p>11. Connect the red remote module wire to pin 1 on the K1 terminal port.</p>	

12. Twist the remote module's blue and white wires together.

13. Connect the twisted blue and white wires to terminal 2 on the K1 terminal port.

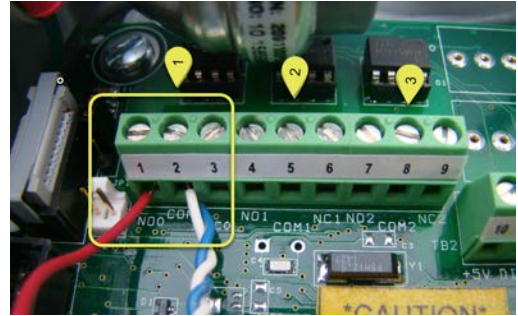

## Eagle Research Corrector Programming and Requirements Notes



**Important!** This information is subject to change without notice. Refer to the Eagle Research product documentation to verify the most current programming and configuration information for the 500G remote module.

Using Itron remote modules with Eagle Research volume correctors requires Eagle Research Field Manager software configured with the parameters for your model of Eagle Research corrector.

### Using Eagle Research Field Manager to Change the MPplus Settings

1. Open the Eagle Research Field Manager from the Start menu or the desktop shortcut.



2. Connect the communications cable from your computer into the MS connector on the side of the MPplus corrector. After the MS connector is connected, take note of the baud rate displayed on the front of the corrector.

3. Click **Connect** on the upper left corner of the Field Manager window.



A Connect to Remote window opens.

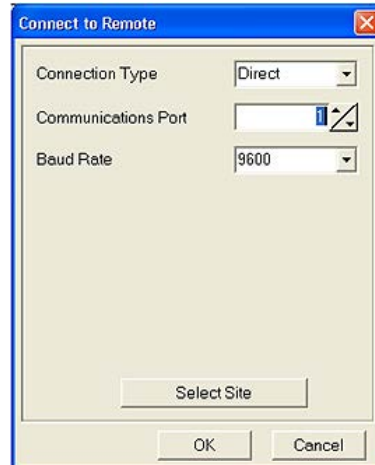

4. Select the following parameters:

- **Connection Type:** Direct
- **Communications Port:** enter your computer's port number
- **Baud Rate:** enter the baud rate that displayed in Step 2.

5. Click **OK**.

6. Click **View/Config**.



The Field Manager window opens and displays the settings for the current connection.

7. Click the **Setup Parameters** tab at the bottom of the parameters window. A parameters window opens.

8. Enable POut 5 (17, 18) and set the additional parameters as required in the **Uncorrected Pulse Output Setup** at the lower right of the window.

 **Important!** If your software does not have an option to use POut for the uncorrected pulse output, contact Eagle Research to get the correct software version.

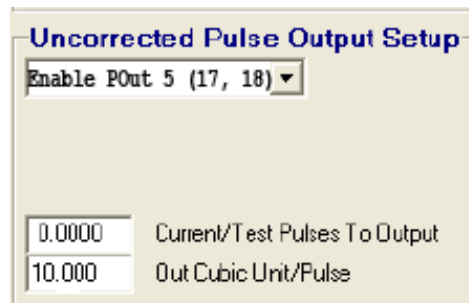



9. Enter the parameters shown in the **Corrected Pulse Output Setup** section in the lower left of the window.

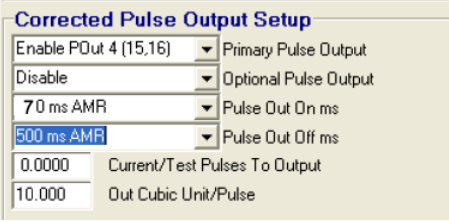

10. Click **Send All Changes**.



11. Verify that all parameters are correct.

12. Click **Disconnect**.

### Using Eagle Research Field Manager to Change the XARTU Corrector Settings

1. Open the Eagle Research Field Manager from the Start menu or the desktop shortcut.



2. Click **Connect** on the upper left corner of the Field Manager window.



3. Select the following parameters:

- **Connection Type:** Direct
- **Communications Port:** Enter your computer's port number.
- **Baud Rate:** Enter the baud rate for the XARTU-1 corrector.

4. Verify that the time and station name are correct.

5. Click **View/Config**.

**Click OK**



6. Click the **Setup Parameters** tab at the bottom of the parameters window.

<p>The Meter Setup and Accumulation Multipliers window opens. Set up the meter and accumulation multipliers as appropriate for your installation.</p>	
<p>7. Enable K2 (4, 5, 6) and set additional parameters are required in the <b>Uncorrected Pulse Output Setup</b> section in the lower right of the window.</p>	
<p>8. Set the <i>Primary Pulse Output</i> to Enable K1 (1, 2, 3) and the <i>Optional Pulse Output</i> to Disable (unless it is used for another application) in the Corrected Pulse Output Setup section in the lower left of the window.</p>	
<p>9. Click <b>Send All Changes</b>.</p>	
<p>10. Verify that all parameters are completed and correct.</p>	
<p>11. Click <b>Disconnect</b>.</p>	

### Eagle Research Programming Notes

During remote module programming for use with the Eagle Research corrector, verify that the module drive rate settings match those set in the corrector. For example, set the module drive rate for 1000 CF when the Eagle Research corrector drive rate is set for 1000 CF.

## Elster American Meter Installation

Some meter manufacturers provide mounting kits and installation procedures for their meters. If the Elster American RPM meter to the remote module installation instructions are not available,

follow the installation procedures in this section.

Meter model	Meter notes	Itron part number
<b>10 Metric (10B)</b>	Originally manufactured by Metric Metal Works	ERG-7000-501
 <p><b>Elster American RPM Series rotary meter</b></p>	Meter must have factory-installed pulser with connector output. Purchase correct cable interface from manufacturer.	ERG-7000-503

## Elster American Installation Overview

Installing the remote module to an Elster American meter involves four tasks.

1. Programming or verifying that the meter is set up to work with the remote module. Programming requires a computer communication cable.
2. Connecting the module to the meter. Connecting the module to the meter requires:
  - a wire stripper
  - a flat-tip screwdriver
3. Mounting the remote module (for mounting information, see [Mounting on page 16](#)). Select the mounting option appropriate for your installation. Mounting options include:
  - Wall mount on a sheet metal surface
  - Pipe mount using the Itron pipe mount kit CFG-0005-003
  - Custom Elster American meter mounting option
4. Programming the remote module. For programming information, see [Programming on page 21](#). Programming requires an Itron programming device (for example, an FC300SR).

module configuration with the meter is dependent on your system application. See the Elster American meter configuration information.

## Elster American Meter Mounting Instructions

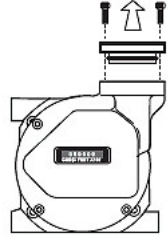
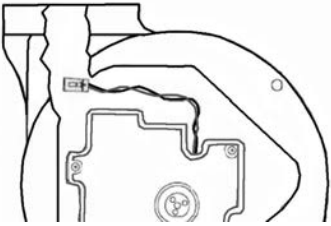
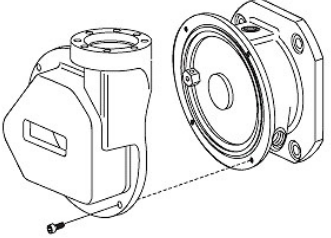
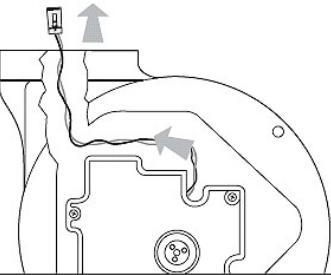
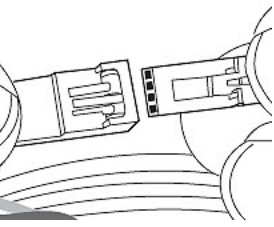
<p>1. Remove the meter's top plate by removing the two 5mm screws and carefully prying up on the plate. The plate is secured with an O-ring seal. Remove the O-ring from the plate.</p> <div style="background-color: #ffffcc; padding: 10px; margin-top: 10px;">  <p><b>Caution:</b> If the O-ring is damaged during removal, obtain a replacement from Elster American Meter Co.</p> </div>	
<p>2. Look into the meter tower and find the meter switch lead and connector (4-pin).</p>	
<p>3. If the lead and connector are not visible or cannot be found, remove the four 5mm mounting screws and the register cover. The meter switch lead and connector will be visible inside the cover.</p>	
<p>4. Feed the lead and connector into the register cover tower.</p> <div style="border-left: 2px solid black; padding-left: 10px; margin-top: 10px;"> <p><b>Note:</b> Save any meter tags. You will re-install them later in the installation process.</p> </div>	
<p>5. If you removed the register cover, replace the cover using the four (4) 5mm mounting screws.</p>	
<p>6. Attach the 4-pin male connector on the Elster American Meter adapter plate to the 4-pin female connector inside the meter's tower. The connectors will slide together and latch.</p>	

7. Carefully push the connectors and wires into the meter tower housing.

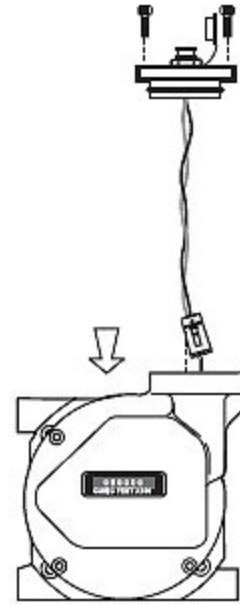

8. Lubricate the O-ring with O-ring lubricant and install the O-ring on the adapter plate. Insert the adapter plate into the tower and tighten the two 5 mm screws.

## Elster American Mechanical and Wiring Installation Instructions

**Note:** Connection to an Elster American meter requires a cable interface compatible to an Elster American RPM rotary meter.

1. Trim the remote module wires to 3.5 inches.



2. Carefully strip the insulation covering from the meter cable (purchased from the meter manufacturer) approximately 1-1/2-inches from the end.



**Caution:** Do not cut through the individual wire insulation.

3. Separate the meter cable's black, white, and red wires for connection to the remote module. Cut off the unused wires even with the outer covering (insulation).



**Caution:** Do not strip the individual wires.

4. Connect the meter cable to the remote module wires using 3M gel-cap connectors following the American RPM meter to remote module wire connection information and wiring diagrams.



**Important!** Use a crimping tool compatible with gel-connectors. *Do not* use standard pliers for crimping gel-connects. For more information, see [Using Gel-cap Connectors to Complete Wiring Connections on page 1](#).

**Wire connection information**

**American meter wire**

**Remote module wire**

Black

Blue

White

White

Red

Red

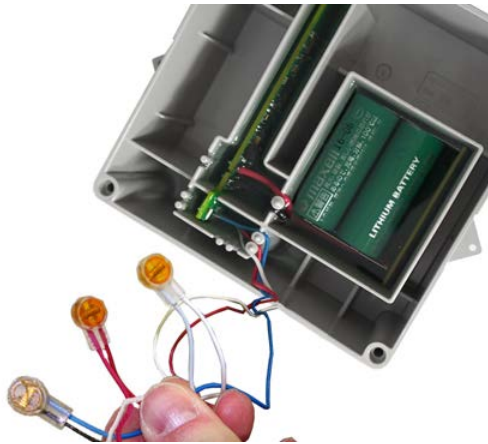

5. Insert the meter cable through the slot on the remote module backplate. Install a cable tie to the meter cable wire below the meter cable insulation to provide strain relief.

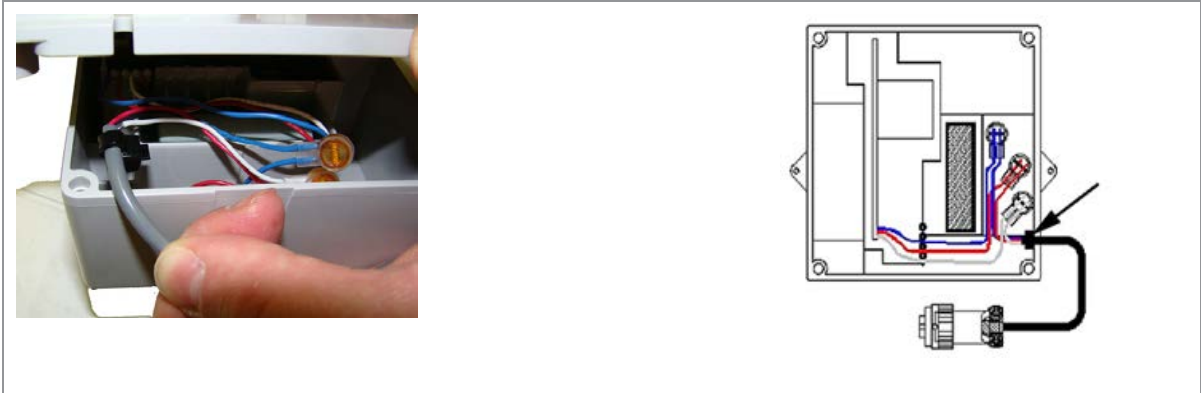

6. Tuck the connectors and cable tie into the remote module housing. Place backplate on the assembly and tighten the 1 backplate screws using a size T-10 Torx screwdriver.

**!** **Important!** Verify that the cable tie and gel connectors are inside the module housing and that the cable extends out of the slot in the backplate. Torque the backplate mounting screws to 9 to 12 inch-pounds.



### Installing the Remote Module Cable

1. Insert the plug on the cable connected to the module into the receptacle on the meter adapter plate.

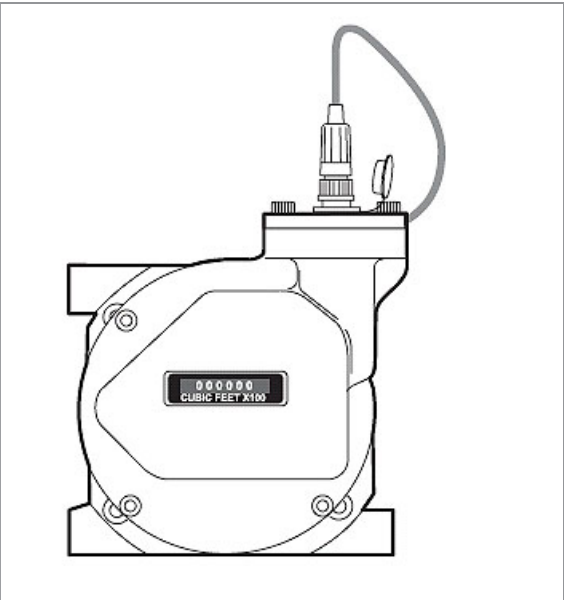

2. Tighten the threaded collar on the plug onto the American Meter interface receptacle. Verify that the connection is hand-tight.

## Galvanic Gas Micro Installation

This section describes installation to Galvanic compatible correctors.

Meter model	Meter notes	Itron part number	module notes
 <p><b>GasMicro Electronic Volume Corrector</b></p>	Must select 2 pulses/second from pulse output on the output frequency menu.	ERG-7000-503	module cut cable requires customer-supplied cable capable of terminating the module white and blue wires at the meter interface.

### Galvanic Installation Overview

Installing the remote module to a Galvanic volume corrector involves four tasks.

1. Programming or verifying that the volume corrector is set up to work with the remote module. Programming requires a computer communication cable.
2. Connecting the module to the volume corrector. Completing the connections requires a wire stripper and flat-tip screwdriver sized to tighten the terminal connections on the Galvanic corrector.
3. Mounting the remote module. Select the mounting option appropriate for your installation. See [Mounting on page 16](#). Mounting options include:
  - Wall mount on a sheet metal surface
  - Pipe mount using the Itron pipe mount kit CFG-0005-003
4. Programming the remote module. For programming information, see [Programming on page 21](#). Programming requires an Itron programming device (for example, an FC300SR).

Remote module configuration with the meter is dependent on your system application. See the Galvanic corrector product documentation for configuration information.

### Galvanic Product Mounting Instructions

See the Galvanic product documentation for custom mounting instructions.



## Galvanic Mechanical and Wiring Installation Instructions



GAS Micro wiring connections		
GAS Micro corrector	P13 connection	100G module wires
Pulse output1-C	C1	Blue/white
Pulse output1-E	C2	Red
Pulse output2-E	C3	
Pulse output2-C	C4	





### Programming the Galvanic Gas Micro Electronic Volume Corrector

For more information about programming the Galvanic Gas Micro Electronic volume corrector, see the *GAS MICRO Operator's Manual*, Galvanic part number MA1956. Contact Galvanic Applied Sciences, Inc to obtain the operator's manual.

## GE Oil and Gas Meter Installation

This section provides the instructions to install the remote module on the following compatible GE Oil and Gas meters.

Meter model	Meter notes	Itron part number	module notes
 <b>D800/D1000</b>	Pulse width must be set greater than 100 ms. Firmware version must be 1.71 or higher.	ERG-7000-503 ERG-7000-505	Both modules are compatible with these meter models.
 <b>B3 Series pulse output meter</b>  <b>LMMA pulse output meter</b>	Rotary meters equipped with WeighandWire solid state pulsers. Meter must have factory-installed pulser with connector output. Purchase correct cable interface from GE Dresser. Pulser must be version 17 or higher.	ERG-7000-503	

Meter model	Meter notes	Itron part number	module notes
 <p><b>Integral Micro Corrector IMC/W2</b></p>  <p><b>Integral Micro Corrector MC2</b></p>	<p>Electronic volume corrector for Series A (LMMA) and Series B (rotary meters). Must be meter firmware version 1.94 or earlier. Pulse width must be set for 125ms.</p>	<p>ERG-7000-505</p>	
 <p><b>Series 3 ES3 meter</b></p>  <p><b>Electronic Temperature Compensator (ETC)</b></p>	<p>Pulse width must be set greater than 100ms. Firmware version 1.71 or earlier.</p>	<p>ERG-7000-503 ERG-7000-505</p>	<p>Both modules are compatible with this meter model.</p>

## GE Oil and Gas Module Installation Overview

Installing the remote module to a GE Dresser meter involves the following tasks.

1. Programming or verifying that the meter is set up to work with the remote module.
  - Programming may require a computer and communication cable.
2. Wiring the GE-supplied cable to the module or wiring the module to the GE device.
 

Wiring may require a wire stripper, flat-tip screwdriver, Torx T-15 screwdriver, and wire crimper. Requirements are dependent on your installation.
3. If your installation uses a GE supplied cable, connect the cable to the meter. If your installation requires wiring directly to the GE device, move to the next step.
4. Mounting the remote module. For more information, see [Mounting on page 16](#). Select the mounting option appropriate for your installation.

- Wall mount on a sheet metal surface
  - Pipe mount using the Itron pipe mount kit CFG-0005-003
  - Custom GE Dresser mounting
    - D800/D1000 mounting solution requires the following materials
      - (1) 8-32 x 1/2" screw
      - (2) 8-32 x 3/4" screws
      - (3) 8-32" Kep nuts
5. Programming the remote module. Programming requires an Itron programming device (for example, an FC300SR). For programming information, see [Programming on page 21](#). Remote module configuration with the meter is dependent on your system application. See the GE Dresser meter product documentation for configuration information.

## GE Oil and Gas Custom Mounting Options

Specific product mounting instructions for GE D800/D1000 meters are included in the D800/D1000 installation section.

### GE Oil and Gas ES3 or ETC Ordered with the AMR-ready Mounting Kit

1. Score (cut) the cable jacket surrounding the ES3 or ETC wires and carefully remove the cable jacket to expose the ES3 or ETC wires.



2. Connect the wires to the module. For more information, see [GE Oil and Gas Meters With Pulse Output Wiring on page 50](#).

3. Align the module mounting holes with the ES3 or ETC bracket mounting holes. Use a T15 Torx screwdriver to insert and tighten the mounting screws. Tighten the screws in an alternating pattern.



**Caution:** Upright vertical positioning is critical because:

- The 500G series modules are optimized for communication and require upright mounting. Any other mounting position could result in reduced RF performance.
- The remote module tilt tamper sensor requires upright mounting. Any other mounting position may cause issues with the module's tilt tamper detection.

### GE Oil and Gas IMC/W2, or MC2 with the GE Mounting Bracket Kit

**Note:** This mounting option requires that you follow the installation instructions to attach the meter manufacturer cable prior to completing this mounting option. This configuration requires the GE mounting bracket kit available from GE Oil and Gas (GE part number 057783-000). The kit includes the listed materials.

Quantity	Description	GE Dresser part number
1	Mounting bracket	015951-000
1	Screw, 8-32 x 7/16-inch	000163-277
2	Screw, 8-32 x 3/4-inch	000163-282
3	Nut, 8-32	012829-005
4	Spacer, #10	053669-001
5	module/bracket mounting screw, M6 x 20 mm	013444-002

**Important!** The GE Oil and Gas mounting bracket kit does not include the cable required to connect the remote module to the Amphenol connector on the IMC\W2.

### Completing the Bracket Installation

1. Insert the 8-32 x 7/16-inch screw (1) into the top of the mounting bracket. Insert the two 8-32 x 3/4-inch screws (2) into the bottom of the mounting bracket.

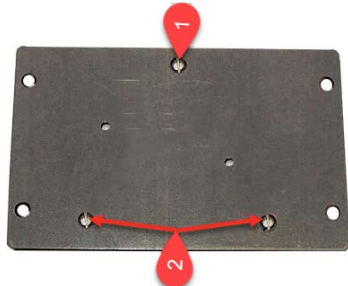

2. Insert one 3/32-inch nut on the top 7/16-inch bracket screw. Slide the 500G remote module mounting lug over the top of the bracket screw and nut.



3. Secure the bottom 500G remote module mounting holes over the two 8-32 x 3/4-inch screws with the remaining two 8-32 nuts.



4. Insert the #10 spacers into the four mounting holes on the back of the IMC\W2.



**Caution:** Upright vertical positioning is very important because the remote module is:

- designed with the antenna in a vertical direction so the antenna is parallel to the reading device (which has a vertical antenna). Matching antenna polarity can greatly affect RF performance and enable easy module reading.
- designed so the tilt tamper is vertical. It is important to maintain vertical positioning in the field to enable tilt tamper stability.
- designed for installation with the batteries vertical (installed with the positive terminal upward). Any other installation orientation will compromise battery life.

5. Secure the module/bracket assembly on the IMC\W2 using four module/mounting bracket screws (M6 x 20 mm). Install tamper seals as required.



6. Connect the cable to the pulse output on the IMC/W2 or MC2.



## GE Oil and Gas Mechanical and Wiring Installation Instructions

This section describes mechanical installation to the GE Oil and Gas meter and wiring connections.

## D800/D1000 Wiring and Installation

1. Loosen and remove the two screws holding the mounting brackets to the meter.



2. After the brackets are removed, the pulse output cable is visible.



3. Loosen the cable gland and pull the cable out until it extends 7.5 to 8" out of the cable gland.



4. Tighten the cable gland. Do not use a pliers or wrench to tighten the cable gland.

5. Rotate one bracket. Route the meter cable through the holes located at the bend of the mounting brackets.



6. Attach the brackets to the meter using the previously removed screws.



7. Splice the meter pulse output wires to the module wires using gel cap connectors. Follow the wire connections for the D800/D1000 to module wire connections below.

**Note:** Use a crimping tool compatible with gel-connectors. Details on using the crimping tool are included in the mounting installation section of this document.

D800/D1000 meter		module			
Pulse output	Wire	Pulse output 1	Pulse output 2	Pulse output 1 with fault	Pulse output 2 with fault
Output 1+	Brown	White and blue		White	
Output 1-	Green	Red		Red	
Output 2+	White		White and blue		White
Output 2-	Black		Red		Red
Output 3+	Red			White	White
Output 3-	Blue			Blue	Blue

8. Install a cable tie strain relief on the cable approximately 1/8" from the end of the cable insulation.



9. Position the cable so the strain relief is just inside the slot on the module's backplate.





10. Carefully fold the module wires into the module's housing. Do not pinch the wires of gel connections between the housing and the backplate.



11. Install the four back plate screws using the T-15 Torx screws supplied with the module.



12. Route the cable through the channel in the backplate standoffs.

13. Insert the 8-32 x 1/2" screw into the top hole in the meter mounting bracket and thread one of the Kep nuts loosely onto the end of the screw.



14. Tilt the bottom of the module away from the mounting bracket and slide the notched mounting hub onto the screw and Kep nut. Do not tighten the screw.

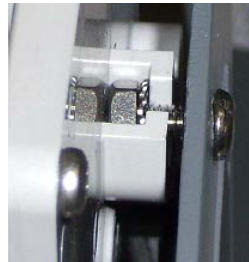

<p>15. Install the bottom two mounting screws and Kep nuts. Tighten the three mounting screws in an alternating pattern.</p>	
<p>16. Install the supplied red tamper seals over the bottom mounting screws on the remote module.</p>	

### GE Oil and Gas Meters With Pulse Output Wiring

These instructions describe B3 series, LMMA series, IMC, IMC/W2, MC2, and Series ES3 and ETC wiring connections. Installations are similar in their wiring of a meter manufacturer cable to the module that is then connected to the index or instrument.

**Note:** Wiring connections are different for the models as described. Use the connections for your specific meter model.

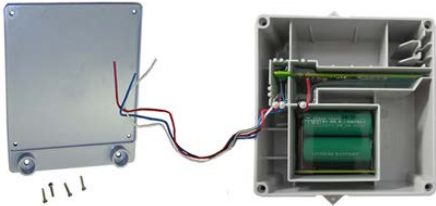
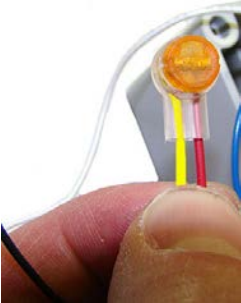
<p>1. Remove the backplate (4 screws) from the module and expose the module lead wires. The backplate and screws will be re-installed on the module later in this procedure, so store them (temporarily) in a safe, secure place.</p>	
<p>2. Insert the lead wires from the module and the correct GE pulse output wire into new 3M gel connectors (Itron part number CON-0023-001) and crimp using a 3M hand-held crimping tool.</p>	

**Note:** Use a crimping tool compatible with gel-connectors. For information about crimping the connections, see [Using Gel-cap Connectors to Complete Wiring Connections on page 1](#). The same process is used for wiring cables to the module. Each meter or cable may have different wire colors and wiring instructions. See the specific wiring configuration for your product. Wiring configurations for the B3, LMMA, IMC/W2, MC2, ES3, and ETC meters with pulse outputs are provided in the following information.

GE supplied cable that connects to a B3, LMMA, IMC/W2, or MC2	module
Blue	Blue
White	White
Red	Red

Pulse output	Wire	Pulse output 1 only	Pulse output with 1 fault
<b>ES3 or ETC</b>		<b>module</b>	
Output 1+	White	White and blue	White
Output 1-	Black	Red	Red
Output 3+	Red		White
Output 3-	Green		Blue

**Wiring for direct connection to the IMC/W2**

**To receive uncorrected reads:** Connect the red wire to terminal block 3 (TB3 telemetry output) GND1 (ground) position (B). Connect the white and blue wires to the pulse output 1 position (A).

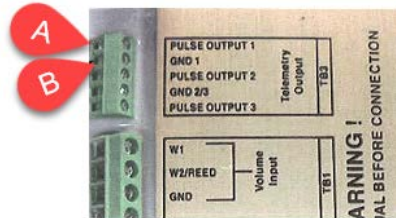

**To receive corrected reads:** Connect the red wire to the GND 2/3 (ground) TB3 telemetry output position (C). Connect the white and blue wires to the pulse output 2 position.

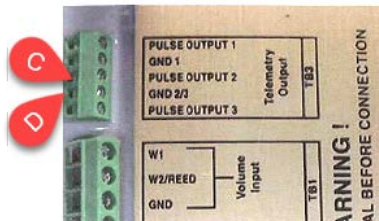

**Wiring for direct connection to the IMC/W2**

3. After completing the wiring connections, install a cable tie to the meter cable just below the exposed colored lead wires on the cable insulation. Remove the excess cable tie using a hand-held side-cutter pliers. The cable tie performs as a cable strain relief to mitigate the risk of destructive tension on the lead wires.

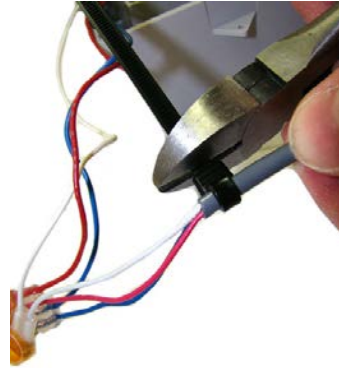

4. Tuck the three gel connectors and cable tie inside the module housing, as shown in the placement illustration and schematic.

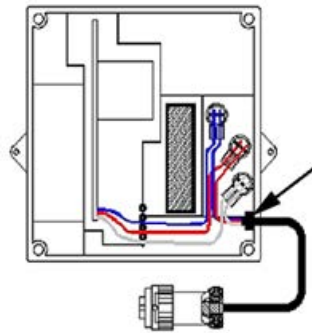

5. Install the remote module backplate using the four screws previously removed from the module and a Torx T-10 screwdriver.

6. Plug the cable into the pulse output of the index.



**Important!** Verify that the cable tie and gel connectors are inside the module housing and that the cable extends out of the backplate slot. Torque the backplate mounting screws 9 to 12 inch-pounds.

7. Mount the module as required for your application. Wall and pipe mount options are described in [Mounting on page 16](#). Additional options for GE specific mounting solutions are described in the product specific mounting instructions in this GE Oil and Gas section.



## GE Oil and Gas Meter Programming and Requirements Notes

GE MeterWare software is used to configure the module's index settings.



**Important!** This information is subject to change without notice. Refer to the GE MeterWare product documentation to verify the most current information about programming and configuring the corrector for use with the remote module.

1. Open the GE Dresser MeterWare software to change the remote module settings.
2. Select the **LiveData** tab.
3. Confirm the firmware version and current index settings.
4. If you change a variable, click **Update Values** to complete the change.
5. Select the Configuration tab to view the volume configuration or confirm the volume configuration and pulse settings. Use the drop-down lists to change the variable's setting.

**Note:** You must click **OK** to complete any setting changes.

### Testing IMC or W2 Communication with GE User Terminal (UT) Communication Software

1. Connect the IMC/W2 to the PC using the serial cable.
  2. Using the GE Dresser User Terminal (UT) communications software, connect to the IMC/W2.
- Read the uncorrected or corrected count number on the remote module with the Itron endpoint reading device. Compare the IMC/W2 uncorrected or corrected amounts to those from the remote module.
4. Input approximately 20 pulses to the remote module. Verify that the uncorrected or corrected counts on the IMC/W2 and the remote module are the same.

### Programming Notes



The following table lists pulse rates for the pulse output of compatible GE indexes.

Index style	Meter size				
	8C-11M	16M	16M-56M	1.5-11M	16M-102M
B3 CTR index	10		100		
B3 TC index (Meter built 1/1999 and beyond)	10	100			
B3 TC index (Meter built prior to 1/1999)	50	500			
LMMA CTR index				10	100
LMMA TC or Series 3 CTR/TC index		100		10	

## Honeywell Instrument Installation

**Note:** This meter is compatible only with devices running on the OpenWay Riva network.

This section provides installation instructions for the remote module on the following compatible Honeywell Instruments.

Meter model	Meter notes	Module type	Itron part number	module notes
 <p><b>Mini-AT</b></p>  <p><b>Mini-Max</b></p>  <p><b>EC-AT</b></p>	<p>Pressure and temperature electronic volume instruments. Instruments must have a Form A board. Form C is NOT supported. Item #56 Pulse Scaling Factor must be 2.0. Item #96 Cor Vol Display must be 7, 6, 5, or 4 digits (1, 2, 3, or 4 blanks). Item #115 Output Pulse Code must be set at 1, 2, or 4. For connection to Mini-Max only, Item #115 must be set at 1 or 2. Item 124 wake up setting on Honeywell corrector must be set to 1. Compatible corrector firmware versions are 2.5020 and 2.73.</p>	500G remote	ERG-7000-502	

Meter model	Meter notes	Module type	Itron part number	module notes
 <p><b>TCI</b></p>	<p>Temperature Compensating Index. TCI must have a Form A board, Form C is NOT supported. Item #56 Pulse Scaling Factor must be 2.0. Compatible TCI firmware versions are 1.06, 1.07, and 1.10.</p>	500G remote	<p>ERG-7000-502 ERG-7000-503</p>	<p>The -502 module has a 5' cable and is used when longer cabling is required. This module will return the cut cable tamper.</p> <p>The -503 module has lead wires designed for use with the TCI mounting bracket. This module will return the cut cable tamper.</p>

## Honeywell Instrument Installation Overview

Installing the remote module to a Honeywell Instrument involves the following tasks.

1. Programming the instrument and verifying that the Honeywell instrument is set up to work with the remote module. Programming requires Honeywell software. Reference Honeywell product and software documentation for the correct software and version requirements.
2. Installing the instrument and any required retrofit components.
3. Mounting the remote module to a pipe or flat vertical surface. For more information, (see [Mounting on page 16](#)).
  - Pipe mount using the Itron pipe mount kit CFG-0005-003.
  - Custom Honeywell mounting using Honeywell Kit 22-1077.
    - Custom mounting requires three #8-32 x 1/2-inch screws, 3 #8 metal flat washers, and 3 rubber sealing washers.
4. Connecting the remote module to the instrument.
5. Programming the remote module. For programming information, see [Programming on page 21](#).

## Honeywell Product Mounting Instructions



### Two Remote Modules Mounted On a Honeywell Mini-Max Instrument

1. Place the Honeywell Instrument volume corrector in *shutdown* condition and disconnect all power from the Mini-Max main board.
2. Remove the battery pack from the volume corrector and set it aside.
3. Remove the four screws from the main board and the board from the enclosure. Set the board aside.
4. Remove the two hex screws from the input switchboard and the switchboard from the enclosure and set it aside. You will re-install the switchboard later.



**Warning!** The battery pack, main board, and switchboard may be damaged if left in the Honeywell Instrument volume corrector while completing this installation.

5. Drill two 3/16-inch holes in the back of the Mini-Max enclosure as specified by the information included in the kit. Remove any metal shavings from the enclosure.
6. Clean the remote modules with the alcohol wipe where you will place the corrected and uncorrected labels (included in the kit).

**Note:** Clean the modules with the alcohol wipe to ensure good label adhesion.

7. Mount the module for *corrected* pulse outputs on the left bracket mounting space.
  - a. Insert three #8-32 x 1/2-inch screws in a triangular pattern.

Install the top screw so the head of the screw is approximately 1/8-inch from the mounting bracket surface.
  - b. Slide the module onto the screw so the mounting lug fits securely onto the screw. If necessary, remove the module and make any necessary adjustment to the screw depth



- to ensure a secure fit.
- c. Install the two bottom screws in an alternating fashion.
8. Mount the module for *uncorrected* pulse outputs on the right bracket mounting space.
    - a. Insert three #8-32 x 1/2-inch screws in a triangular pattern.

Install the top screw so the head of the screw is approximately 1/8-inch from the mounting bracket surface.
    - b. Slide the module onto the screw so the mounting lug fits securely onto the screw. If necessary, remove the module and make any necessary adjustment to the screw depth to ensure a secure fit.
    - c. Install the two bottom screws in an alternating fashion.
  9. Route the module cables under the bracket edge and toward the rear of the Honeywell Instrument.
  10. Mount the mounting bracket (Honeywell Instrument part number 22-1077, included in the kit) onto the Mini-Max enclosure.
    - a. Place a #8 metal flat washer followed by a rubber sealing washer onto both #8-32 x 3/8-inch screws.
    - b. Align the lower threaded holes in the mounting bracket with the drilled enclosure holes and insert a screw/washer through the enclosure housing. Screws heads must be inside the enclosure.
    - c. Tighten both screws using a screwdriver.

**Note:** Aligning the second bracket threaded hole and drilled hole may require some manipulation of the mounting bracket.
  11. Insert the module cables (both units) through the large cable strain relief on the left rear of the instrument's enclosure. Leave a one-half to one inch drip loop under the cable strain relief.
  12. Secure three cable ties on the module cables in three places on the cables as specified by information included in the kit.
  13. Re-install the input switchboard, main board, and battery pack removed in step 2.

## Honeywell Mechanical and Wiring Installation Instructions

This section includes the information to wire two modules to a single Honeywell Instrument. Installation requires the correct programming parameters (for programming parameters, see [Programming on page 21](#)).

## Connecting to a Honeywell Mini-AT, Mini-Max, or EC-AT

With Itron remote modules, utilities can receive *corrected* and *uncorrected* consumption values by installing two modules. The module for *corrected* reads is attached to the corrector's pulse output. The module for *uncorrected* reads is attached to the input switch board. The *corrected* pulse output is programmable, and the *uncorrected* pulse output is dependent on the connected meter's drive rate.



**Important!** Some Honeywell Instruments have two pulse outputs so the *uncorrected* pulse output could be connected to the additional output, but the connection should be to the input switch board in case the corrector battery fails. Counts will be collected if the *uncorrected* pulse is connected to the switch board since the board is not dependent on battery power.

This installation procedure requires a Honeywell mounting kit (Honeywell part number 22-1077). The illustrations show connection to a Honeywell Mini-AT. Connection to the Honeywell EC-AT and Mini-AT are similar to these instructions. See Honeywell product documentation for more information.

1. Connect the *corrected* module wires to TB1 on the Mini-Max board following the Corrected module connection information. Use Honeywell upgrade kit 40-2678-1 to provide the second pulse output channel for the uncorrected endpoint.

2. Insert the remote module cable into the instrument's compression connector.

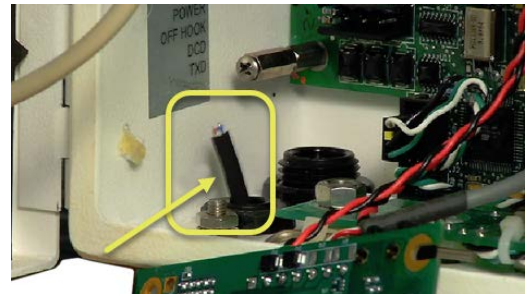

3. Strip one inch of the outer insulation from the cable.



**Warning!** Keep wires away from the rotating magnetic spindle in the Honeywell Instrument.

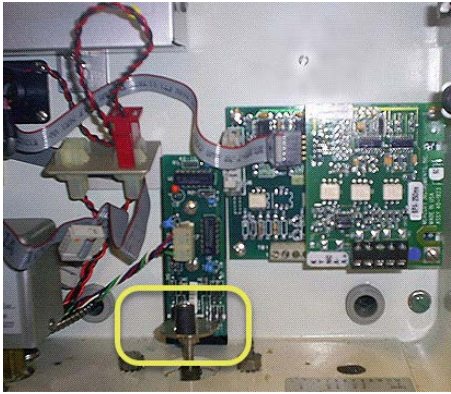

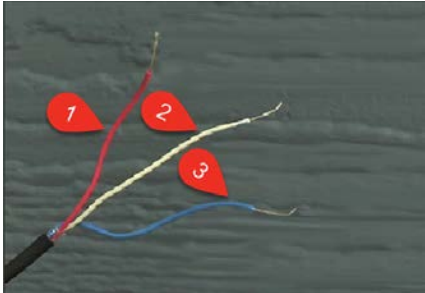

4. Strip ¼-inch individual wire insulation from the red, white, and blue lead wires.

- a. Count enabling wire (pulsed ground reference)
- b. Count sensing wire (high impedance positive reference)
- c. Cut cable sensing wire (positive return)

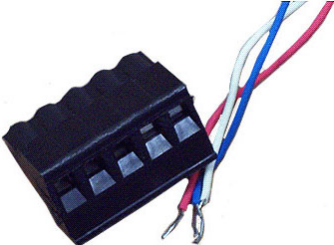

5. Twist the blue and white wires together and connect them to the Honeywell Instrument terminal strip connector (Phoenix connector) following the Honeywell Instrument Item Code Settings. For Item Code Settings, see [Programming the Honeywell Instrument Parameters on page 64](#).



6. Connect the red wire following the Item Code Settings. For Item Code Settings, see [Programming the Honeywell Instrument Parameters on page 64](#).

**Note:** In Honeywell Instrument EC-AT correctors, the connector may be soldered to the pulse board.



<b>Corrected module connections</b>	
<b>Mini-Max TB1</b>	<b>module wire color</b>
K terminal	Red
Ya terminal	Blue*

Ya terminal	White*
*Twist the blue and white module wires together before connecting them to the Mini-Max board. Tighten the terminal connection securely.	
7. Connect the <i>uncorrected</i> module wires to the Input Switch Board UNC. VOL following the table below.	
<b>Uncorrected module connections</b>	
<b>Mini-Max input switch board unc. vol.</b>	<b>module wire color</b>
COM terminal	Red
No terminal	Blue*
No terminal	White*
*Twist the blue and white module wires together before connecting them to the Mini-Max board. Tighten the terminal connection securely.	
8. Tighten the large strain relief securely.	
 <b>Warning!</b> Do not crush the module through-cables when tightening the strain relief.	
9. Re-install or reconnect the power or battery sources.	
10. Close the instrument case and tighten the case screw securely. Replace any locks that were removed for installation.	
11. Install the remote module. See <a href="#">Mounting on page 16</a> .	



### Connecting to the Honeywell TCI

The Honeywell Instruments Temperature Compensating Index (TCI) provides two Form-A volume pulse outputs and one Form-B alarm output. These outputs are electronic switches. The Form-A pulse outputs are configurable for compensated or uncompensated volume. The Form-B output is for alarm output use only.





Connections to the three output pulse channels are completed using loose unterminated wires (the individual wires from a cable) and gel-connectors. The TCI unit has six unterminated wires that require six gel-connectors (Itron part number CON-0023-001) to enable pulse connections

to ancillary devices. Loose wires are located inside the gray adapter plate behind the black strain relief fitting.

		
<p><b>Strain relief fitting</b></p>	<p><b>Honeywell TCI strain relief tether</b></p>	<p><b>Backplate black fitting with loose cable wires (Honeywell part number 22-1929)</b></p>

### Completing the Connections

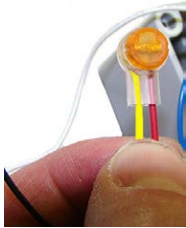
<p>1. Connect the remote module to receive TCI pulse readings.</p> <p><b>Note:</b> Connect one module/channel to the alarm output if the modules are used on channels A and B.</p>	
<p>2. Remove strain relief fitting by unscrewing it from the gray adapter plate.</p> <p><b>Note:</b> Do not remove the fitting's hex nut. Unscrew the entire fitting from the gray adapter plate. A tether line is secured to the strain relief fitting. When the strain relief fitting is removed, the tether line pulls the unterminated wires out of the adapter plate for access to the loose wires.</p>	
<p>3. Loosen the strain relief fitting hex nut and remove the white plug from the center.</p>	
<p>4. Place the strain relief fitting onto the field pulse cable.</p>	
<p>5. If the field pulse cable is smaller than a 0.2-inch diameter, install the rubber tube supplied with the TCI onto the cable so the strain relief will clamp onto the tube after it is reinstalled.</p>	
<p>6. Connect the individual external pulse cable conductors to the unterminated wires following <i>Configuration for two modules connected to one TCI</i>.</p>	
<p><b>Configuration for two modules connected to one TCI</b></p>	
<p><b>Channel A</b></p>	
<p><b>TCI</b></p>	<p><b>module wire</b></p>
<p>Orange and brown</p>	<p>White</p>

Yellow	Red
Blue (alarm)	Blue
<b>Channel B</b>	
<b>TCI</b>	<b>module wire</b>
White	White
Green	Red
White	Blue
7. Insert one unterminated wire into an opening of a gel-connector (six gel-connectors were included with the TCI).	
8. Insert the appropriate field cable wire into the other gel-connector opening.	
9. Verify that both wires are fully inserted into the gel-connector prior to crimping.	
<div style="border: 1px solid #ccc; padding: 10px; background-color: #e6f2ff;"> <p> <b>Important!</b> Use a crimping tool compatible with gel-connectors. <i>Do not</i> use a standard pliers for crimping gel-connects. See <a href="#">Using Gel-cap Connectors to Complete Wiring Connections on page 1</a>.</p> </div>	
10. Insert the gel-connected wires into the threaded gray adapter plate hole.	
11. Replace the strain relief and tighten until secure.	

## Honeywell Instrument Programming and Requirements

The Honeywell MasterLink SQL software is used to configure Honeywell products.

 **Important!** This information is subject to change without notice. Refer to the Honeywell MasterLink SQL product documentation to verify the most current information about programming and configuring the corrector for use with the remote module.

## Honeywell Software Settings

1. Connect the interface cable from the Honeywell instrument to a PC loaded with the MasterLink SQL software.

2. Open the MasterLink SQL software. The software opens and reports a "Not Connected" status.

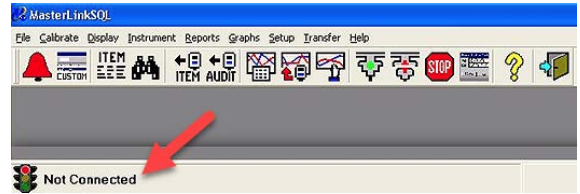

The Site List window automatically opens after the software detects an instrument.

3. Select the Honeywell instrument type from the **Instrument List** on the right of the screen.

**Important!** You must select the correct instrument type. Selecting the incorrect type causes communication errors.

4. The status indicator in the lower left corner of the MasterLink SQL software displays the connection status as Connected (instrument type).

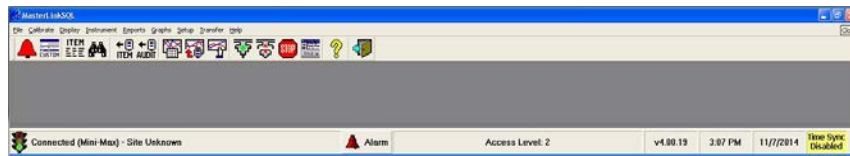

5. To view an Item configuration, select Display > Items by Number.

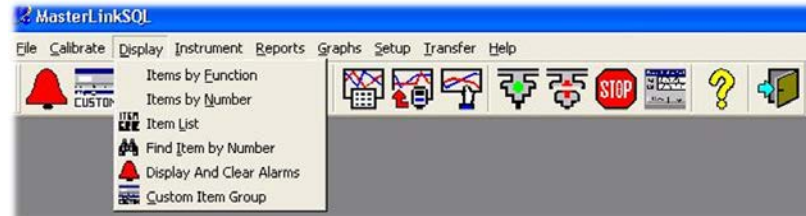

6. Verify that the Honeywell instrument settings are correct. For example, Item number 56 must be set to 2.0. If the setting is incorrect, click the **Change** button.

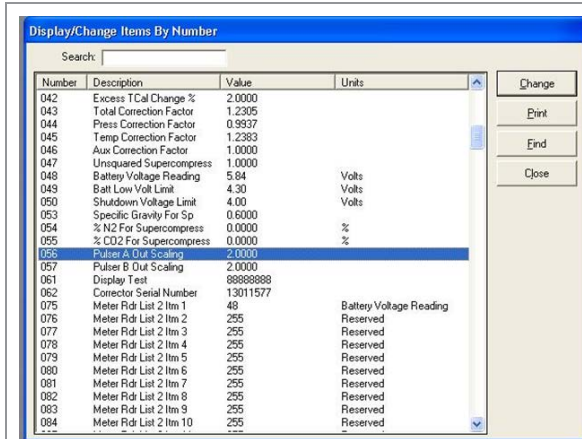

A Change Item pop-up provides the interface to change the setting.

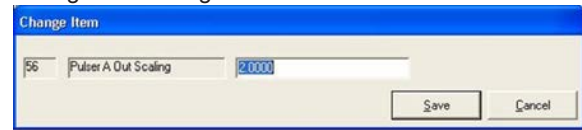

7. Enter the correct setting. Click **Save**.

8. Confirm that all settings match the settings required for the module connected to the Honeywell Instrument. For more information, see compatible modules listed in [Honeywell Instrument Installation on page 54](#).

### Programming the Honeywell Instrument Parameters

Program the Honeywell Instrument parameters following these Item Code Settings.

Instrument	Pulse Output Options	Channel A Corrected Volume		Channel B Uncorrected Volume		Channel C		Pulse Output Spacing			Terminal Board Connections / Wiring
		#56	#93	#57	#94	#58	#95	#115	#1014	#1015	
ECAT	Pulse Board Ver-2(3) Form A	2	Cor Vol	2	Unc Vol	2	Cor Vol	1=1.0sec or 2=2.0sec or 4=0.5sec			Red wire goes to K  Blue and White wires go to Y  Connection must be on same terminal board channel (for example, Ka/Ya; kb/Yb; Kc/Yc)  Ka, Ya=Channel A  Kb, Yb=Channel B  Kc, Yc=Channel C
	Pulse board Ver-3(2) FormC1 FormA					2	Cor Vol				
Mini with Form A main board	Main board Type-2*	2	Cor Vol								
Mini-AT	JB29,JB30 &JB31 Jumpered for FormA*	2	Cor Vol	2	Unc Vol						
Mini-Max	All main boards	2	Cor Vol	2	Unc Vol			1=1.0sec or			



		Channel A Corrected Volume		Channel B Uncorrected Volume		Channel C		Pulse Output Spacing			
Instrument-	Pulse Output Options	#56	#93	#57	#94	#58	#95	#115	#1014	#1015	Terminal Board Connections / Wiring
								2=2.0sec			
TCI	FormA main board	2	Cor Vol	2	Cor Vol				Itron 100G	Itron 100G	

## Itron Meter Installation

See for Itron meter installation information for the A-Series (1A, 305, 400, 675, and 1000) meters.

Meter model	Meter notes	Itron part number	Notes
<b>1A</b>	Flat-face meter body and 1A adapter plate have interference fit issue causing direct-mount solution to be non-compatible.	ERG-7000-501	
<b>305</b>	#2 flat-face meter		

Meter model	Meter notes	Itron part number	Notes
 <p>400</p>	#3 flat-face meter		
 <p>675, 1000</p>	Front-mount index	ERG-7000-501	Requires a thicker gasket for magnet hub to clear index box. 1-hole gasket: FAB-0014-001 2-hole gasket: FAB-0014-002 4-hole gasket: FAB-0014-003



## National Meter Installation

National/Lancaster meters are compatible with remote module with an encoder cable. For installation instructions, see [Diaphragm Meter Installation on page 80](#).

Meter model	Meter notes	Module type	Itron part number	module notes
 <p>All meters</p>	Where direct mount solution is not compatible	500G	ERG-7000-501	

## Romet Meter Installation

This section describes installation for Romet meters and correctors compatible with Itron remote modules.

Meter model	Meter notes	Module type	Itron part number	module notes
 <p><b>RM Series STD CTR</b> 600-5600 TC 2000-23000</p>	<p>Meter must have factory-installed pulser with connector output. Purchase cable interface from manufacturer.</p>	Cellular 500G remote module	ERG-7000-503	
 <p><b>RM Series Electronically compensated meter</b> ECM2 600-56000</p>	<p>Meter must have connector pin with factory-installed pulse output. Purchase correct cable interface from Romet.</p>			
 <p><b>AdEM Series Correctors</b> including AdEM-S, AdEM-T, and AdEM-PTZ</p>	<p>Must be configured to 350mS of output pulse spacing and 30mS of output pulse width.</p>			

### Romet Installation Overview

Remote module installation with the Romet series correctors involves the following tasks.

1. Programming or verifying the that corrector is set up to work with the remote module.  
 Programming requires a computer loaded with the RometLink software and a Romet computer-to-corrector communication cable.

2. Connecting the module to the corrector. Installation requires the following materials.
  - Connection options, Cannon cable (part number: 43-035-40\*) pigtail option
  - Romet AdEM communication cable, available from Romet
  - RometLink communication software, available from Romet
  - 3 gel cap connectors, Itron part number CON-0023-001
  - 3M crimping tool
  - Torx T-10 screwdriver
  - Remote module with backplate and four included Torx screws (included with module)
3. Mounting the remote module (for more information, see [Mounting on page 16](#)). Select the mounting option appropriate for your installation. Mounting options include:
  - Wall mount on a sheet metal surface
  - Pipe mount using the Itron pipe mount kit CFG-0005-003
  - Custom Romet mounting (see Romet documentation for custom mounting)
4. Programming the remote module. For programming information, see [Programming on page 21](#). Programming requires an Itron programming device (for example, an FC300SR).

## Romet Product Mounting Instructions

### Romet ECM2 to remote module mounting option

**Note:** This mounting option requires a Romet mounting kit (Rommet part number 34-444-1-KIT).



1. Remove the module screw from the back of the ECM2 meter.



**Romet ECM2 to remote module mounting option**

2. Insert the mounting screw fitted with the three lock washers. Two lock washers are used as spacers (as shown).



3. Attach the mounting plate to the meter. Insert the mounting screw where the module screw was removed. Torque the mounting screw to 5-7 ft.lbs. to secure the plate to the Romet meter.



4. Mount the remote module using the pre-drilled holes on the mounting plate and the module mounting screws.

5. Place new tamper seals over the two screws. Press tamper seals into place using an 11/32-inch nut driver or similar blunt tool.

6. Connect the module to the meter using the previously installed cable interface.



## Romet Mechanical and Wiring Installation Instructions

These instructions describe installation with Romet cables and setup options for the AdEM corrector and ECM2 meter. These instructions include the two most common setup configurations. For specialized setup instructions, contact Romet.

1. Remove the module backplate (4 screws) to expose the module lead wires. The backplate and screws will be re-installed on the module later in this procedure so store them (temporarily) in a safe, secure place.

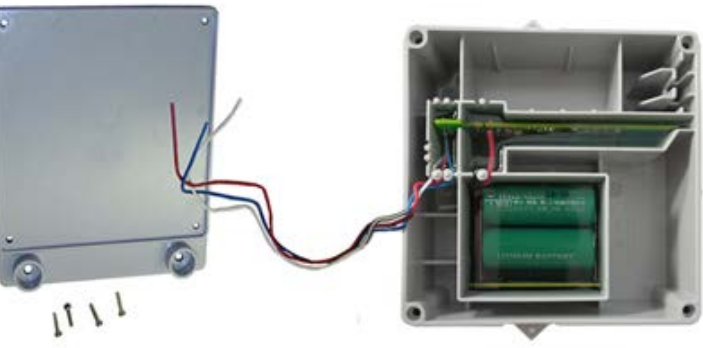

---

2. Insert the lead wires from the module into new 3M gel connectors (Itron part number CON-0023-001) together with the lead wire from the meter cable (see wiring connections).

---

3. Crimp the connectors using a 3M hand-held crimping tool.

!

**Important!** Use a crimping tool compatible with gel-connectors. *Do not* use a standard pliers for crimping gel connectors. For more information, see [Using Gel-cap Connectors to Complete Wiring Connections](#) on page 1. Follow the correct wiring configuration for your Romet corrector or meter from the following wiring parameters.

### Standard AdEM Romet 43-035-40 Cable Wiring

Connection	Corrected count		Uncorrected count	
	Romet cable	wire	Romet cable	wire
Pulse Output 1+	Green	White	Red	White
		Blue		Blue
Pulse Output 1-	White	Red	Black	Red

**Note:** This wiring configuration will not allow a cut cable tamper.

### Romet PG9 Pigtail Cable Wiring

Connection	Corrected count	
	Romet cable	module
Pulse Output 1+	White	White
Pulse Output 1-	Red	Red

Connection	Corrected count	
	Romet cable	module
Cut Cable Alarm	Green	Blue

**Note:** The pigtail cable is the cable extruding from the back of the AdEM corrector. You must select the pigtail cable at the time the AdEM corrector is ordered.

### Romet ECM2 Meter Wiring

**The Romet ECM2 meter**

The meter has three Form "A" outputs that can be configured at the factory to provide any combination of the following three outputs:

- Uncorrected volume (UNC VOL)
- Corrected volume (COR VOL)
- Alarm

The pulse weight for the volumetric outputs is configured in *Setup Mode* at **Menu items > SET UNC OUT** and **Menu items > SET COR OUT**. Since Setup Mode is fully configurable, the ECM2 module is universally adaptable to all Romet TC meter bodies. Reference the Romet technical manual for specific details on the ECM2.

### Romet Cable Number 34-125-20

Cable pin	module wire		
	Corrected	Uncorrected	Alarm
A	White and blue		
B	Red	Red	
C		White and blue	
D			Red
E			White and blue

### Romet Cable Number 34-125-40 or 34-125-41

Cable pin	module wire		
	Corrected	Uncorrected	Alarm
A		White and blue	
B		Red	
C	White and blue		
D	Red		

Cable pin	module wire		
	Corrected	Uncorrected	Alarm
E			White and blue
F			Red

**Romet Cable Number 34-125-42**

Cable pin	module wire		
	Corrected	Uncorrected	Alarm
A	White and blue		
B	Red		
C			White and blue
D			Red
E		White and blue	
F		Red	

**Romet cable number 34-125-43**

Cable pin	module wire		
	Corrected	Aux CC	Alarm
A	White and blue		
B	Red		
C		White and blue	
D		Red	
E			White and blue
F			Red

**Romet Cable Number 34-125-44**

Cable pin	module wire
	Aux CC
A	
B	
C	White and blue



Cable pin	module wire	
	Aux CC	
D	Red	
E		
F		

**Romet Cable Number 34-125-45**

Cable pin	module wire		
	Corrected	Uncorrected	Alarm
A		White and blue	
B		Red	
C			White and blue
D	Red		
E	White and blue		
F			Red

**Romet Cable Number 34-125-50**

Cable pin	module wire		
	Corrected	Uncorrected	Alarm
1		Red	
2	White and blue		
3		White and blue	
4			Red
5	Red		
6			White and blue

*Romet Cable Number 34-125-51*

Cable pin	module wire		
	Correct	Uncorrected	Aux CC
1		Red	
2	White and blue		

Cable pin	module wire		Aux CC
	Correct	Uncorrected	
3		White and blue	
4			Red
5	Red		
6			White and blue

4. After the wire connections are completed, install a cable tie to the meter cable just below the exposed colored lead wires on the cable insulation.

5. Remove the excess cable tie using a hand-held side-cutter pliers. The cable tie performs as a cable strain relief to mitigate the risk of destructive tension on the lead wires.

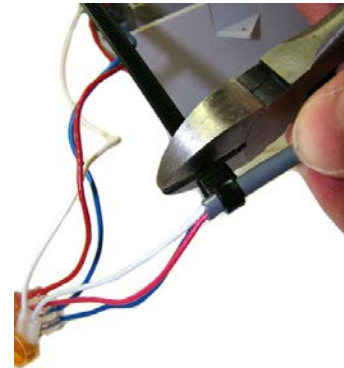

6. Tuck the three gel connectors and cable tie inside the module housing, as shown in the following placement illustration and schematic.

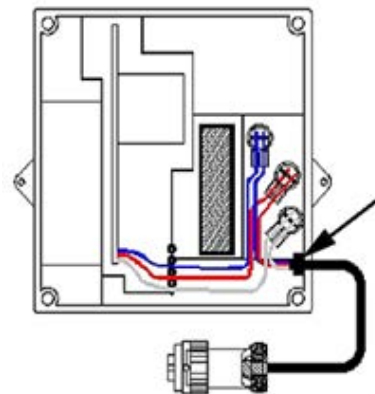

7. Install the remote module backplate using the four screws previously removed from the module and a Torx T-10 screwdriver.



**Important!** Verify that the cable tie and gel connectors are inside the module housing and the cable extends out of the slot in the backplate. Torque the backplate mounting screws to 9 to 12 inch-pounds.

8. Install the module on the wall or a pipe using the pipe installation kit (Itron part number CFG-0005-003) or install the module on the Romet AdEM meter using the Romet mounting bracket (Romet part number 46-444-2).

## Romet Corrector Programming and Requirements Notes

### AdEM Programming

**Note:** Meter setup requires confirmation of communication settings with the AdEM corrector. Communication confirmation requires the RometLink software and the Romet communication cable.

1. Install the RometLink software on your PC.
2. Connect the AdEM corrector communication cable to your computer and the AdEM corrector.
3. Add the AdEM meter to your *Phone Book*.
- 3a. Open the RometLink software and log on.

3b. From the *Talk to Unit* tab, select **Check > All**.

Click **Yes**.

A dialog box opens asking if you want to add the unit in the *Phone Book*.

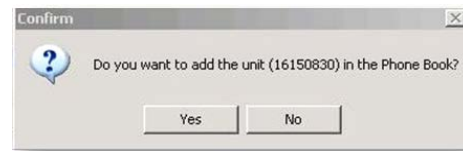
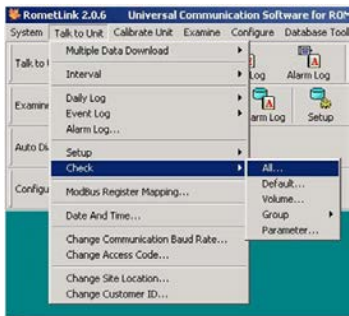

3c. Click **Close**.



3d. Confirm that the meter was added to the Phone Book.

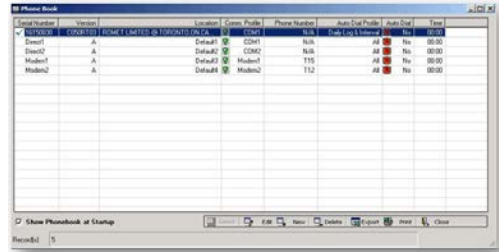

3e. Set up the corrected or uncorrected parameters.

3f. From the *Talk to Unit* tab, select **Setup > Default**.

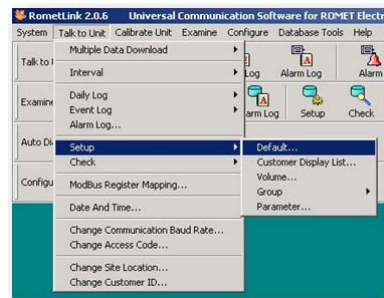

3g. Set the following *Default Setup Group* parameters:

- Enter the desired **Cor. Volume Unit** parameter. Set **Cor. Pulse Volume** to the same number of units.
- For **Output Pulse Spacing**, enter the largest number over 285mS that works for your application. Itron recommends a setting of **350mS**.
- For **Output Pulse Width**, enter the largest number over 28mS that works for your application. Itron recommends a setting of **30mS**.

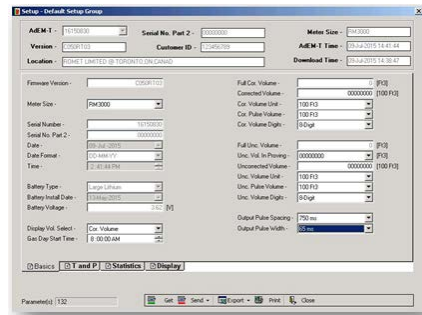

3h. Click **Send** at the bottom of the page.

3i. Select **Current Page**.

### ECM2 programming

4. Set the ECM2 output pulse spacing to 750ms for operation with the 500G remote module. Output spacing represents an *off-time* between pulses.

## Sensus Meter Installation

This section describes remote module installation on compatible Sensus meters.

Meter model	Meter notes	Itron part number	Module notes
 <p data-bbox="298 573 597 678"><b>Sonix pulse output 12, 16, 25, 57 (Metric)</b> <b>600, 880, 2000 (cubic foot)</b></p>	<p data-bbox="630 268 919 449">Sonix meters are pulse output registers which are programmed by Sensus software. Proper pulse output options and display options must be selected.</p>	<p data-bbox="959 268 1127 296">ERG-7000-503</p>	

## Sensus Meter Installation Overview

Installing the remote module to a Sensus meter involves the following tasks:

1. Programming the meter.
2. Mounting the remote module. The module may be mounted on a pipe or flat surface (see [Mounting on page 16](#)). Select the mounting option appropriate for your installation. Mounting options include:
  - Wall mount on a sheet metal surface
  - Pipe mount using the Itron pipe mount kit CFG-0005-003
3. Connecting the remote module to the meter.
4. Programming the remote module. For programming information, see [Programming on page 21](#).

## Sensus Product Mounting Instructions

The Sensus factory can direct mount the remote module to Sensus Sonix Meters (contact Sensus North American Gas Customer Service for mounting specifications and ordering information). This section includes the instructions for customers to mount the module on the Sonix meter using the mounting materials available from Sensus Metering Systems.

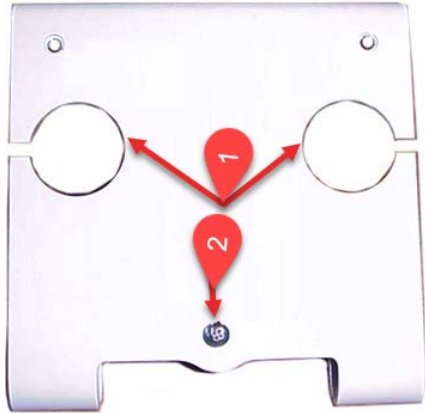

1	Top anchor screw positions
2	Bottom anchor position for the module U-shaped mount

Order the correct Sensus Sonix direct mount bracket for your installation requirements from Sensus North American Gas Customer Service. (Brackets and mounting hardware are ordered separately).

Sensus Sonix direct mount brackets* and mounting hardware	
Sensus part number	Description
60025-063-00000	1 1/2" FTP, 45Lt, #3 Spg, 60Lt, #4 Spg
60025-063-01000	2" - 11BS, 2" FTP
60025-063-02000	30Lt, #1A Spg, 1 1/4" NPT, #2 Spg, 20Lt
903376	#8-32 x 3/4" SS Fillister-head screws (2 required)
011-14-286-00	Rubber mounting washer (stabilizes bracket and remote module assembly)

**Installing the Remote Module on the Mounting Bracket**

1. Place the module mounting bracket over the inlet or outlet pipe fitting on the Sonix meter. (The default position is over the inlet connection. The inlet connection is the left side connection looking at the front of the meter.)
2. Remove the four module backplate screws and turn the backplate so the module mounting screw holes are to the top of the module (the arrow on the module label must point up). Secure the module with the four module backplate screws that were previously removed.
3. Slide the mounting lug (now on the bottom of the module) over the bottom anchor. Insert the two top module mounting screws and tighten in an alternating pattern.

## Sensus Meter Mechanical and Wiring Installation Instructions

Sensus Sonix meters provide a standard Form A electronic pulse output compatible with the remote module. You may connect the Sensus Sonix meter to the remote module using the pulse output cable or you can directly mount the remote module to the meter.

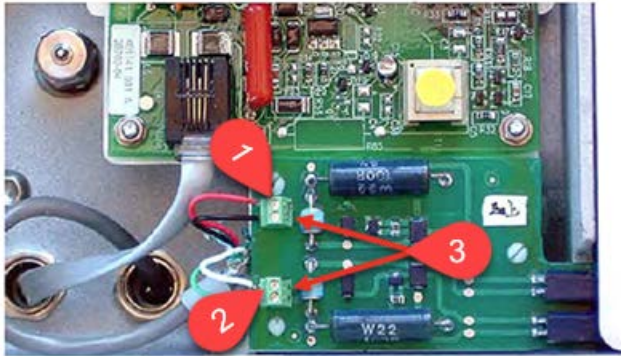

Sensus meter wiring			
<b>Sensus Sonix 2000 meter pulse output options</b>			
Option	(1) Pulse 1 (+)	(2) Pulse 2 (+)	(3) Ground (-)
1	Uncorrected	Corrected	
2	LCD index volume	Alarm	
<b>Sensus Sonix 600 or 880 meter wiring</b>			
Meter wire		module wire	
Red		White and blue	
Black		Red	

For more information about programming wiring parameters, contact Sensus North American Gas Customer Service.

## Sensus Meter Programming and Requirements Notes

Using the SonixCom software, configure the Sensus Sonix meter parameters with the following the Sensus pulse output settings.

- 1 pulse per 10 cf
- 1 pulse per 100 cf
- 1 pulse per 1000 cf

# 6

## Diaphragm Meter Installation

This chapter provides the instructions to install remote modules (Itron part number ERG-7000-501 with 2.5-foot cable and encoder) on diaphragm gas meters where a direct mount module is not possible.

Meter model	Meter notes	Itron part number	module notes
Elster American 10 Metric (10B)	Originally manufactured by Metric Metal Works	ERG-7000-501	
Itron 1A	Flat-face meter where meter body and 1A adapter plate have interference fit issue causing direct mount solution to be non-compatible		
Itron 305	#2 flat-face meter		
Itron 400	#3 flat-face meter		
Itron 675, 1000	Front-mount index	ERG-7000-501	Requires a thicker gasket for magnet hub to clear index box. 1-hole gasket: FAB-0014-001 2-hole gasket: FAB-0014-002 3-hole gasket: FAB-0014-003



### Diaphragm Meter Installation Overview

Diaphragm meter installation involves the following tasks:



1. Programming the module. For programming information, see [Programming on page 21](#).
2. Mounting the remote module. For mounting information, see [Mounting on page 16](#).  
Mounting options include:
  - Wall mount on a sheet metal surface
  - Pipe mount using the Itron pipe mount kit CFG-0005-003
3. Connecting the remote module to the diaphragm meter.

The following materials are required for each remote module installation to a diaphragm gas meter. Purchase these items from Itron.



Part Number	Description	
ERG-7000-501	Cellular 500G remote module with 2.5' encoder cable	
CFG-0081-001	Remote mount encoder kit 1. acetone applicator stick 2. tamper seals 3. cable ties 4. mounting screws 5. magnet hub spacer 6. magnet hub	
013-1723-112	Encoder spacing tool. Use the Encoder Spacing Tool to ensure that the encoder mounts the correct distance from the magnet hub on the meter index.	

The Itron replacement index cover gaskets shown below are thicker than standard gaskets and have a special slot to accommodate the encoder cable. *Gaskets are designed for Schlumberger/Sprague model 675 and 1000 commercial diaphragm meters. These gaskets may be incompatible on meters from other manufacturers; alternate cable relief procedures may be necessary.*

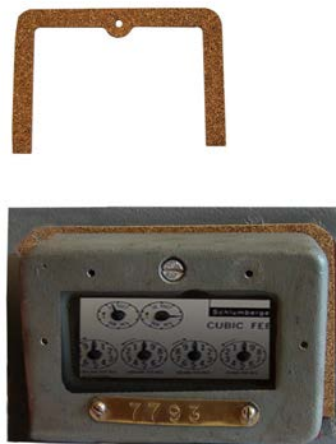
4-hole front cover gasket: Itron part number FAB-0014-003	2-hole front cover gasket: Itron part number FAB-0014-002	1-hole front cover gasket: Itron part number FAB-0014-001
		

## Module Mounting

For remote module mounting with the diaphragm meter, see [Mounting on page 16](#).

## Diaphragm Meter Mechanical and Wiring Installation Instructions



**Caution:** The remote module encoder must be installed at temperatures between 40° and 95°F to ensure proper adhesion.

1. Remove the diaphragm meter index cover and index. Use care to hold the index cover and index while loosening the screws to protect them from damage if they are dropped.
  - a. Remove the index cover screws in an alternating pattern. Hold the index cover while the screws are removed to protect it from damage due to being dropped.
  - b. Remove the index cover and set aside.
  - c. Remove the screws holding the index to the meter. Hold the index to protect it from damage due to being dropped.
  - d. Set the index aside.



2. Remove the old gasket and any gasket residue from the meter and index cover.



3. Remove the magnet hub from the encoder installation kit (Itron part number CFG-0081-001). Verify that there is only one magnet in the hub.

**Note:** If there is no magnet or if there are two magnets in the magnet hub, discard the hub. Encoder installation requires a magnet hub with one magnet.



4. Briefly place the magnet side of the magnet hub into the curved indentation in the encoder as shown in the illustration.

Remove the magnet hub from the encoder and set it at least one inch away from the encoder.

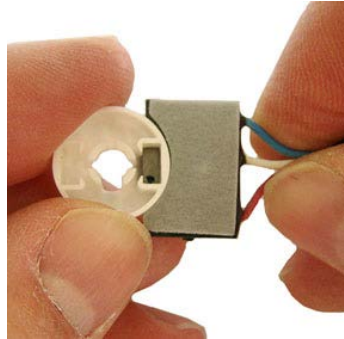

5. Use an module programming device to read the remote module. If this reading is higher than the reading taken after the index was removed, the remote is counting and working properly.

**Note:** If the reading is not higher than the previous reading, the remote module is not working properly. Repeat steps 4 and 5. If the module count is not incrementing, replace the remote module and perform steps 4 and 5.

6. Align the large notch in the magnet hub spacer with the needle of the index meter drive rate dial (1- or 2-foot for residential diaphragm meters; 5-, 10-, or 100-foot for commercial diaphragm meters). Press the magnet hub spacer down over the dial needle as far as possible. The tip on the bottom of the spacer may touch the index face. Turn the dial in the direction noted on the index after the hub is in place to verify the index dial functions with a smooth, easy rotation.



7. Align the pointer (1) on the top of the magnet hub and the notch (2) in the side of the magnet hub with the needle (3) of the meter drive rate dial.



8. Press the magnet hub down over the hub spacer as far as possible. The bottom of the hub spacer may touch the index face. Turn the dial after magnet hub installation to verify that the index dial functions with a smooth, easy rotation.



9. If the dial needle tip sticks out past the edge of the magnet hub, cut off the end of the dial needle as close as possible to the magnet hub with sharp, side-cutting pliers.



10. Remove the acetone stick applicator from the remote encoder installation kit (Itron part number CFG-0081-001). Select a location on the index face next to the magnet hub for the encoder installation. After installation, the encoder cable must not interfere with the index dials.

**Note:** If a TEMP COMP sticker is attached to the index where the encoder cable will mount, remove it before cleaning with the acetone stick. If the sticker (or replacement sticker) must be put back on the register face, place it in a new location on the index face after the encoder is attached.



11. Tilt the acetone stick vertically with the applicator foam end down. Squeeze the acetone stick on the black dot until the packet inside the pen breaks. Continue to hold the pen in a vertical position until the acetone wicks into the foam applicator end. Apply a thorough coat of acetone to the index where the encoder will be installed. Do not touch the area where the acetone was applied before the encoder is installed.

12. Slide the thin end of the encoder spacing tool down over the magnet hub.



13. Peel the protective plastic away from the adhesive side of the encoder.

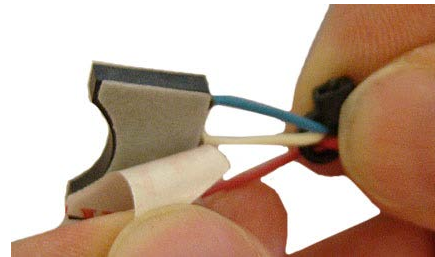

**Important!** You must do the next two steps exactly as described or the remote module will not work properly.

14. Press the curved side of the encoder firmly against the side of the encoder spacing tool as shown below, with the adhesive side down. Slide the encoder down along the side of the encoder spacing tool until it touches the surface of the index (as shown below). Using moderate pressure, hold the encoder firmly against the index, without moving, for 15 seconds to permanently apply the encoder.



15. Remove the encoder spacing tool and lay the index on a flat, horizontal surface to reduce strain on the encoder cable.



16. Program the index reading (with the encoder mounted) into the remote module. Read the remote module and verify that the reading matches the read programmed into the remote module.

17. Use the correct replacement gasket for your meter's index. Remove the gasket center and index cover-hole plugs from the new gasket. Insert the index and encoder assembly through the gasket center with the gasket's adhesive-backed side facing the meter.



18. Align the index wriggler with the meter's drive dog. Install the index on the meter using the index mounting screws. Tighten one index screw two turns. Install and tighten the remaining index screw. Tighten the first index mounting screw completely (alternating fashion).

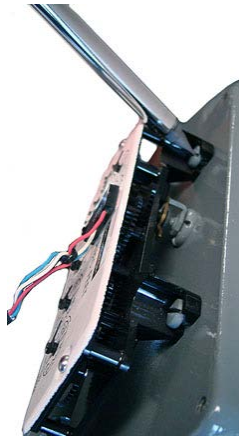

19. Install a strain-relief cable tie about 1-1/4-inch from the encoder cable's stripped end. The cable tie must be inside the index cover after the cover is installed on the meter. Remove any excess cable tie with a side-cutting pliers and dispose the excess cable tie.



20. Remove the protective backing on the replacement gasket to expose the adhesive side of the gasket. Align the gasket (1), encoder cable (2), and cable tie (for strain-relief) (3) on the meter as shown.

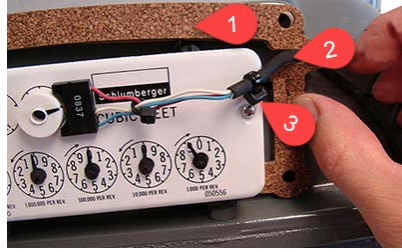

**Caution:** Route the encoder cable inside the index cover to provide strain relief (minimize pulling or twisting on the encoder). Verify that the strain-relief cable tie on the encoder cable is inside the index cover when the cover is installed on the meter. The gasket must align with the index cover screw holes and adhere to the meter face to ensure a proper seal after the index cover is installed.

21. Install the four index cover screws and tighten just enough to hold the screws in place.



22. Verify that the encoder cable is in the correct position in the cable slot of the gasket. Fully tighten the screws in an alternating pattern. Install utility-approved security seals and wires as required.



# Programming and Requirements Notes for Diaphragm Meter Installations

For remote module programming, see [Programming](#) on page 21.

## Residential Module Programming Notes

The module is programmed based on the meter's drive rate. Take note of the index drive rate shown on a lower dial on the index. Elster American meter index drive rates are either 1-cubic foot, 2-cubic feet or 0.05 cubic meters (not shown below).

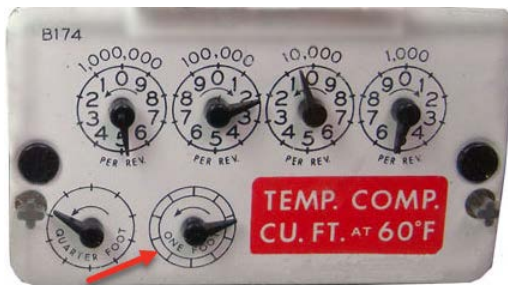

## Commercial Module Programming Notes

Take note of the index drive rate shown on the index. The is programmed based on the drive rate. Elster American commercial meter index drive rates may be 5-, 10- or 100 cubic feet. The index shown has a 10-cubic foot drive rate.

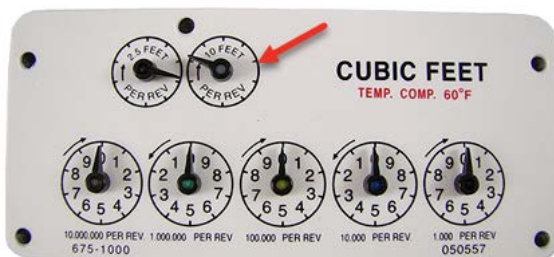



# 7

## Using Gel-cap Connectors to Complete Wiring Connections

This section provides the instructions to complete remote module to meter wiring connections. Gel-cap connections require:

- E-9R 3M gel-cap crimping tool
- 3M gel-cap connectors (Itron part number CON-0023-001)

1. Push the two wires into the connector as far as possible.



**Caution:** Do not strip insulation from the ends of the wires before inserting them into the connector.



2. Place the connector and connector wires into the jaws of the crimping tool. Ensure that the wires remain fully inserted in the connector.



3. Squeeze the handles to crimp the connector. Apply pressure until the cap is fully seated (at least three seconds).



4. The connector is properly crimped when the top of the moveable yellow center (1) is flush with the top of the connector body (2).

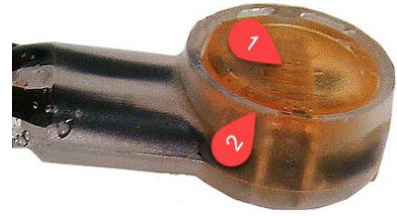

**Warning!** Crimping the connector forces sealant out of the connector. The sealant protects the inside of the connector against insects, moisture, or other contaminants. The sealant may cause minor eye and skin irritation. Avoid eye contact. For more information or Safety Data Sheet (SDS) information, visit the manufacturer website.



# 8

## Optional Sealant Application Instructions

In areas where insect intrusion is a problem, Itron recommends an optional sealant to help keep insects out of the module housing. The Itron-tested and approved sealant (Itron part number ADH-5106-000) is used to seal gaps in remote module installations that can allow insect intrusion.



1. Prepare the module for the sealant by verifying the application area is clean and dry.



**Warning!** Apply sealant in a well-ventilated area.

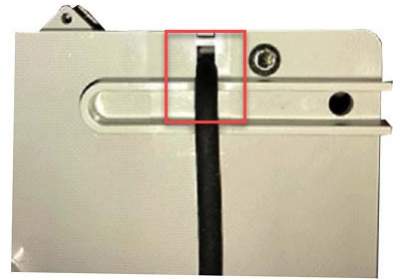

2. Itron recommends sealant application after the remote module is installed so the cable is in the installation position. Use the sealant (ADH-5106-000) to fill the gap.



3. Use enough sealant to fill the gap. Wipe off any excess sealant and replace the cover on the sealant tube.

