

CHAPTER 5

National (Lancaster) Meter Installation

This chapter provides instructions to install the 100G ERT module on 175 - 250 CFH National (Lancaster) meters.



Removing the Meter Index

Begin the module installation by removing the index cover and index from the meter.

To remove the index from the meter

1. Remove any tamper seals from the index cover screws. Remove the index cover screws and the index cover from the meter. Discard the index cover mounting screws and index cover. The 100G includes new, different-size ERT module mounting screws



Note You may use the removed index cover as a temporary storage container for screws. Properly dispose all unused screws, old index covers, gaskets, tamper seals, and other leftover materials. Do not leave materials on customer premises.

2. Remove one index mounting screw completely. Hold one hand under the index to catch the screw.
3. While you remove the other mounting screw, pull the index away from the meter to keep the index backplate against the back of the screw.

4. Remove the screw completely after the index is free of the meter.



5. Set the index aside where it will not be damaged or fill with dirt, rain, or snow. You will mount the index in the ERT module later in this procedure.
6. Discard the index mounting screws. The 100G for National (Lancaster) meters includes new, different-sized index mounting screws (see [Installation Prerequisites](#) on page 14 for screw information).
7. Remove the old gasket, gasket residue, and dirt from the meter (if applicable). The meter face must be free of gasket residue or dirt before you install the 100G assembly.

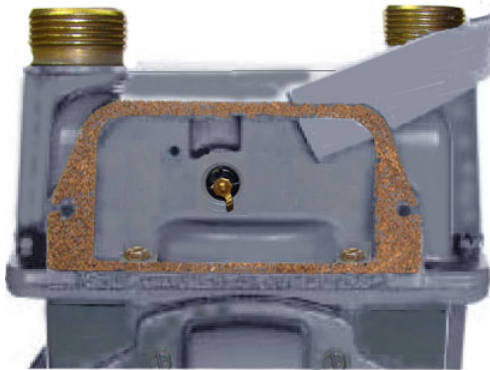

Assembling the Gas ERT Module and Index

Continue ERT module installation by assembling the ERT module and index.

To assemble the 100G series gas ERT module and index

1. Separate the 100G housing from the cover by pulling the cover straight out from the housing.



- Set the ERT cover aside where it will not be damaged or fill with rain, dirt, or snow. You will use the cover later in this installation procedure.

Caution Use only dial-type indexes from National, Actaris, Schlumberger, or Sprague meters with the 100G.

Indexes with bow-tie shaped wrigglers are not compatible with the 100G. You must use a compatible index.

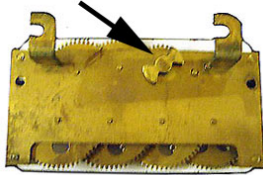

Note National (Lancaster) meter indexes are available in different models:



Indexes with legs



Indexes with mounting holes

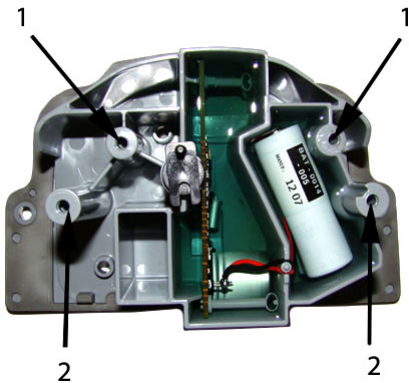

Some National meter indexes have index legs to mount the index on the meter or ERT. Some indexes have both legs and index mounting holes and some have just mounting holes. Mounting methods are dependent on the index. Index types require different mounting screws to attach the index to the 100G housing (see [Installation Prerequisites](#) on page 14). Indexes with legs must be mounted to the ERT housing mounting posts (1). Indexes with mounting holes must be attached to the ERT housing's bracket mounting posts (2).

If your index has legs with mounting screw slots, skip steps 3 and 4. If your index has mounting screw holes in the index back plate (no legs), perform steps 3 and 4, and skip steps 5 and 6.

- For indexes with mounting screw holes in the index back plate (no legs), use the replacement index mounting screws (SCR-0037-001, see [Installation Prerequisites](#) on page 14). Place one screw into the index's right-hand mounting screw hole.

Note National index mounting screws are thread-forming screws and may require more torque.



National (Lancaster) Meter Installation

4. Attach the screw to the ERT housing's right-index mounting post just enough to hold the screw and the right end of the index in place.
5. For indexes with legs (mounting slots), screw one 10 - 20 x 3/8-inch screw (SCR-0017-001, see [Installation Prerequisites](#) on page 14 for screw information) into the right index mounting post one or two turns. Do not completely tighten the screw.
6. Place the right index mounting screw slot under the screw head. Do not completely tighten the screw.
7. Carefully slide the index drive post into the ERT shaft slot. Verify positive engagement of the index wiggler to the ERT shaft. (The following illustrations show index to shaft placement with positive engagement.)

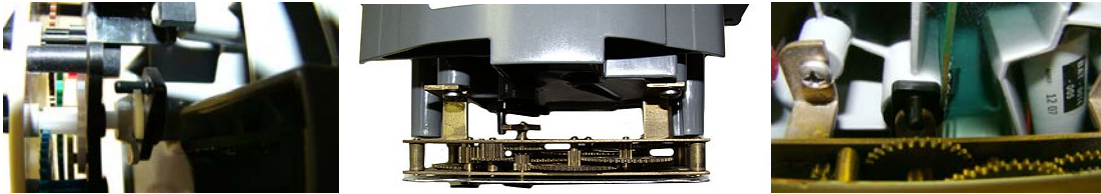

Warning Verify the index drive slot engages with the 100G shaft. Failure to mate the ERT shaft with the index drive post (or slot) can cause binding and lead to poor registration or meter failure.

8. Install and tighten the left index mounting screw (for indexes with either mounting screw slots or holes). Tighten the right index mounting screw. Tighten each index mounting screw evenly.



Warning Slide indexes with mounting screw slots all the way to the right. Verify the ERT module shaft is aligned with the index drive post. Hold the index tightly in place while you secure the index mounting screws.

9. Slide the ERT module cover over the index and housing. Verify the cover is installed correctly. The ERT module label should be clearly visible and easily read.



Programming the 100G Gas ERT Module Assembly

Program the **100G**, **100G DL**, **100G DLN**, or **100G DLT** ERT modules using:

- An FC200SR handheld computer with Field Deployment Manager (FDM) software version 1.1 or higher
or
- A FC300 with SRead handheld computer with Field Deployment Manager (FDM) software version 1.1 or higher
or
- A 900MHz Belt Clip Radio with Field Deployment Manager (FDM) software version 1.1 or higher and a customer-supplied laptop. The Belt Clip Radio connects to the user-supplied laptop using a USB cable or Bluetooth.

The **100G DLS ERT** modules support enhanced security with the Itron Security Manager. Enabling command or enhanced security requires additional programming. Program the 100G DLS ERT modules using:

- An FC200SR handheld computer with Field Deployment Manager (FDM) software version 3.3 or higher
or
- An FC300 with SRead handheld computer with Field Deployment Manager (FDM) software version 3.3 or higher
or
- A 900MHz Belt Clip Radio with Field Deployment Manager (FDM) software version 3.3 or higher and a customer-supplied laptop. The Belt Clip Radio connects to the user-supplied laptop using a USB cable or Bluetooth.

To enable enhanced security and for more complete programming information, see the *Field Deployment Manager Endpoint Tools Mobile Application Guide* (TDC-0934).



FC200SR

FC300 with SRead

900MHz Belt Clip Radio



Caution You must program the 100G gas module before use.

Take note of the index drive rate shown on a top right dial on the index. The endpoint is programmed based on the drive rate. National/Lancaster meter index drive rates are typically 2-cubic feet.

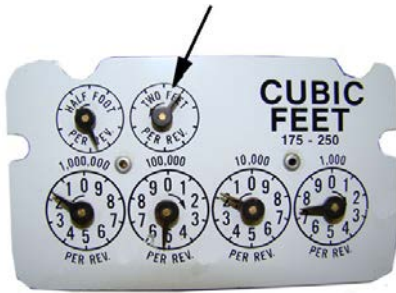

To program the ERT module assembly

1. Program the meter drive rate into the 100G series gas ERT module using the endpoint programming device.
2. For all programming and *Check Endpoint* operations, hold the handheld programmer as close to vertical as possible. For optimal results, keep the handheld programmer within 6 feet of the target ERT module.
3. Verify you have the correct programming mode (Fixed Network Mode, Mobile High Power Mode, Mobile/Handheld Mode, or Hard to Read Mobile/Handheld Mode) for your application.
4. Programming parameters are based on the configuration file loaded into the ERT module programming device. During programming, the 100G is set to the nearest 100 cubic feet; the last two digits (tens and units) are programmed as zeros (0). After programming is complete, the ERT module assembly will read to the nearest cubic foot.

Installing the 100G Gas ERT Module Assembly on the Meter

After you program the ERT module, complete the ERT module installation by installing the module on the meter.

To install the 100G series gas ERT module on the meter

1. Align the black wiggler (1) so one of its four drive *fins* lines up with the meter's drive dog (2).

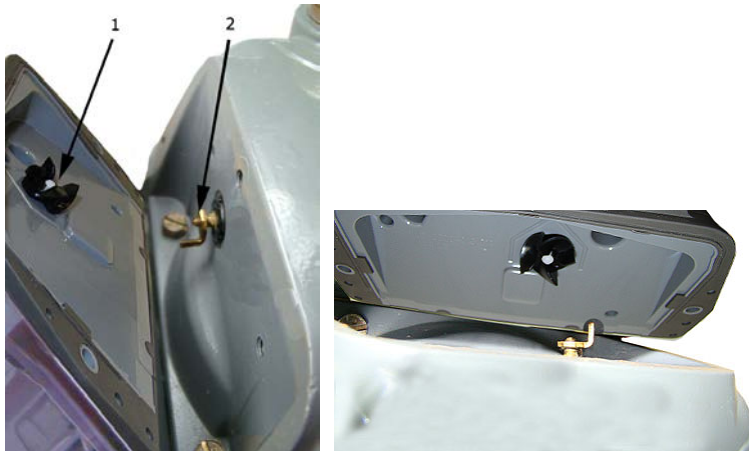

- Carefully place the 100G on the meter.

Warning Failure to correctly align the meter drive post and ERT module wriggler can cause binding and lead to poor registration or meter failure. If there is a gap between the ERT module gasket and the meter, it may be the wriggler of the ERT module is *dead-headed* against the meter drive dog as shown in the following illustration.

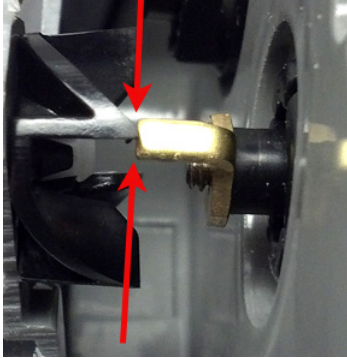

Remove the 100G assembly and repeat the alignment procedure. You must engage the meter drive dog in the ERT module wriggler.

- Insert the right module mounting screw and tighten the screw until the gasket is against the meter. Do not completely tighten the mounting screw.

Note Use the original mounting screws to mount the 100G if they were the correct size and not corroded. If you discarded the original screws, use the correct replacement screws (see [Installation Prerequisites](#) on page 14.)

- Slightly raise the left side of the ERT module (the module will rotate on the right screw) until the left ERT module mounting hole is approximately 1/4-inch above the left meter mounting hole.



5. Rotate the ERT module down until the ERT module mounting hole is approximately 1/4-inch below the meter index mounting hole.

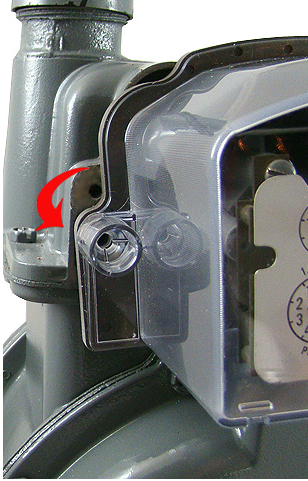

6. Rotate the ERT up to align the left mounting holes. Raising and lowering the ERT module on the meter drive post facilitates the proper positioning and engagement of ERT module wriggler with the meter drive post.

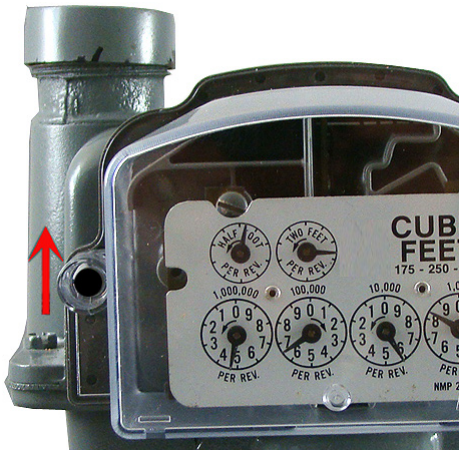

7. Insert the left mounting screw and tighten a few turns.
8. Tighten the right and left ERT-to-meter mounting screws in an alternating pattern. Tighten each mounting screw evenly.

Important Meter manufacturers: torque the mounting screws 15 to 20 inch-pounds.

Tip The following conditions ensure proper engagement of the ERT module to the meter:

- The ERT module fits flush against the meter body--there are no gaps between the ERT gasket and the meter body.
- The ERT module mounting holes align with the index cover mounting holes on the meter body.
- The meter test dial moves in relation to gas flowing through the meter.

National (Lancaster) Meter Installation

- Place a new tamper seal in the tamper seal cups surrounding the two mounting screws. Press the new tamper seals into place using an 11/32-inch nut driver or similar blunt tool.



- Complete any necessary paperwork and properly dispose excess installation materials and scrap from the customer premises.

100G series gas ERT module installation on the National (Lancaster) meter is complete.

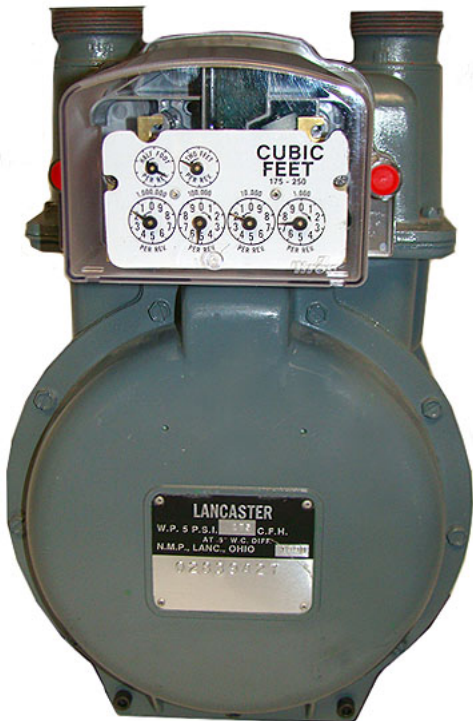

CHAPTER 6

Elster American and Itron Commercial Meter Installation

This chapter provides instructions to install the 100G on Elster American meter and Itron commercial meters.

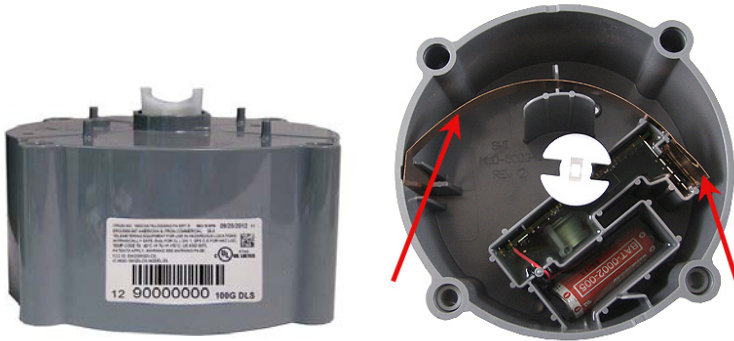

 **Warning** Handle the commercial 100G carefully so the metal passive radiator antenna is not damaged.

Removing the Index or Index Assembly from the Meter

Commercial ERT modules mount on Elster American meters in various configurations. These instructions show metal mounting plates without tamper seal cups and plastic mounting plates with tamper seal cups to represent mounting plate options. Begin ERT module installation by removing the index or index assembly from the commercial meter.



Mounting plate with tamper seal cups Mounting plate without tamper seal cups

Indexes may be mounted on the 100G commercial Elster American meter gas ERT module without mounting plates.



Index covers may (or may not) have tamper seal cups (on the back of the cover) for added security. Index removal assumes the installer removes any tamper seals or wires before continuing with these instructions.



Note It may not be necessary to dismantle your commercial index assembly (index and cover). These instructions do not include index/cover assembly for those applications.

Some diaphragm commercial meters do not require an index assembly mounting plate. Indexes can be mounted directly to the ERT module.

To remove the index assembly

1. Remove any tamper seals (1) (or wire seals) from the index cover and mounting plate screws (2). Set the index and cover assembly aside. You will re-install it later in these instructions.

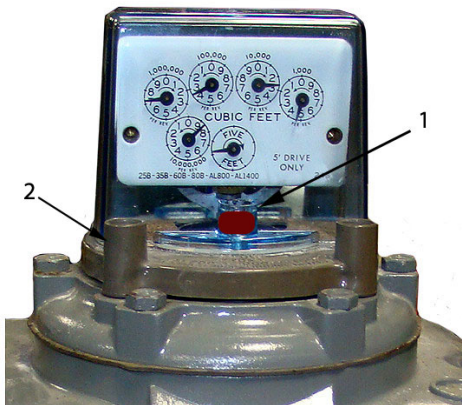

2. Remove the index cover screws from the meter. Verify screws are 1/2-inch long and are not corroded. If the screws are the correct length and are not corroded, keep them to re-install the 100G assembly later in this procedure. If the screws are damaged or not the correct length, discard.



Note Properly dispose all unused screws, old index covers, gaskets, tamper seals, and other leftover materials. Do not leave materials on customer premises.

3. Remove the tamper seals from the mounting plate.

4. Remove the mounting plate screws and separate the mounting plate from the meter. Place the mounting plate where it will not be damaged. You may use it later in this installation.



Programming the 100G Datalogging Commercial Gas ERT

Program commercial **100G**, **100G DL**, **100G DLN**, or **100G DLT** ERT modules using:

- An FC200SR handheld computer with Field Deployment Manager (FDM) software version 1.1 or higher
or
- A FC300 with SRead handheld computer with Field Deployment Manager (FDM) software version 1.1 or higher
or
- A 900MHz Belt Clip Radio with Field Deployment Manager (FDM) software version 1.1 or higher and a customer-supplied laptop. The Belt Clip Radio connects to the user-supplied laptop using a USB cable or Bluetooth.

The **100G DLS ERT** modules support enhanced security with the Itron Security Manager. Enabling command or enhanced security requires additional programming. Program the 100G DLS ERT modules using:

- An FC200SR handheld computer with Field Deployment Manager (FDM) software version 3.3 or higher
or
- An FC300 with SRead handheld computer with Field Deployment Manager (FDM) software version 3.3 or higher
or
- A 900MHz Belt Clip Radio with Field Deployment Manager (FDM) software version 3.3 or higher and a customer-supplied laptop. The Belt Clip Radio connects to the user-supplied laptop using a USB cable or Bluetooth.

To enable enhanced security and for more complete programming information, see the *Field Deployment Manager Endpoint Tools Mobile Application Guide* (TDC-0934).



FC200SR

FC300 with SRead

900MHz Belt Clip Radio



Caution You must program the 100G commercial ERT module before use.

Take note of the index drive rate shown on the index. The ERT is programmed based on the drive rate. Elster American commercial meter index drive rates may be 5-, 10- or 100 cubic feet. The index shown has a 10-cubic foot drive rate.

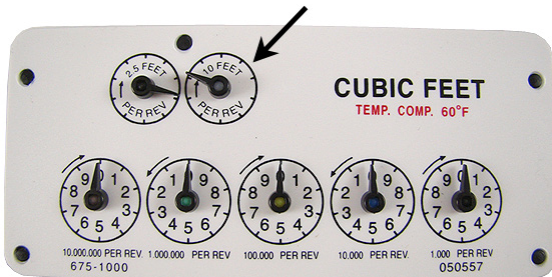

To program the commercial gas ERT module

1. Program the index drive rate into the 100G using the endpoint programming device.
2. For all programming and "Check Endpoint" operations, hold the handheld as close to vertical as possible. For best success, keep the handheld programmer within 6 feet of the target endpoint.
3. Verify you have the correct programming mode (Fixed Network Mode, Mobile High Power Mode, Mobile/Handheld Mode, or Hard to Read Mobile/Handheld Mode) for your application. Programming parameters are based on the configuration file loaded into the endpoint programming device. During programming, the 100G is set to the nearest 100 cubic feet; the last two digits (tens and units) are programmed as zeros (0). After programming is complete, the ERT assembly will read to the nearest cubic foot.

- Slowly turn the ERT module's drive shaft two turns in the direction shown on the index drive rate. This verifies the ERT module is counting properly.



Caution Do not turn the drive shaft faster than one turn per second.

- Read** or **Check** the 100G using the endpoint programming device.
 - If the read result is higher than the number programmed in Step 1, the 100G is counting correctly.
 - If the read result is not higher than the number programmed in Step 1, replace the 100G.

Attaching the Commercial 100G Gas ERT Module Assembly on the Commercial Meter

After you program the commercial gas ERT module, attach it to the commercial meter.

To attach the commercial gas ERT to the Elster American commercial meter

Warning Handle the 100G carefully so the metal passive radiator antenna is not damaged.



- Tilt the 100G at an angle and turn the wiggler until the drive notches line up with the meter wiggler's drive teeth.

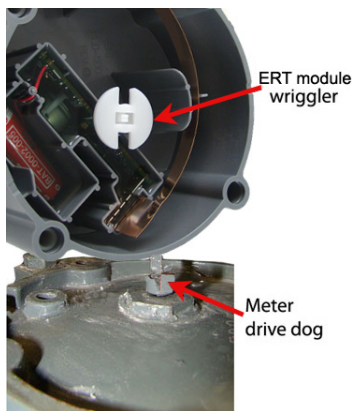

Warning Failure to properly align the 100G DLS wiggler with the meter drive post can cause binding and lead to poor registration or meter failure.

- Align the ERT module so the screw holes line up with the meter's top screw holes. Carefully lower the module on the meter with the wriggler notches lining up with the meter's drive dog teeth.

Warning The INLET label on the 100G must line up with the INLET label on the meter case.

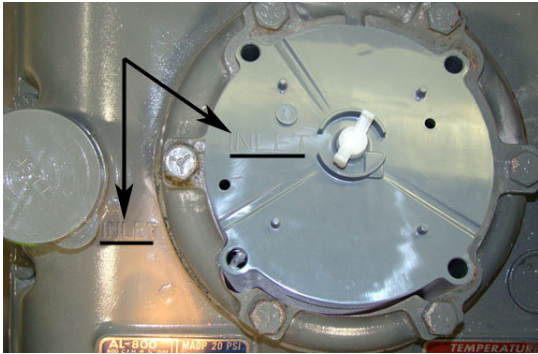

- Verify the bottom of the ERT module and the top of the meter meet. The ERT module housing should rest on top of the meter without gaps.

Warning Do not press down on the 100G if a gap exists between the ERT module and the meter. A gap may be caused by misalignment of the ERT module wriggler and meter's drive post. Pushing down on the ERT module could damage the ERT module wriggler or meter drive post. To eliminate a gap, slowly turn the ERT module's drive shaft back and forth until the module aligns with the meter's drive teeth.



- Place the index cover mounting plate on the commercial 100G so the printing "FLOW FRONT AL800 AL1000 AL1400 AL2300 AL5000 TURBINE ROTARY" stamped on the plate is toward the front of the meter. (A gap between the mounting plate and meter at the screw locations is normal.)

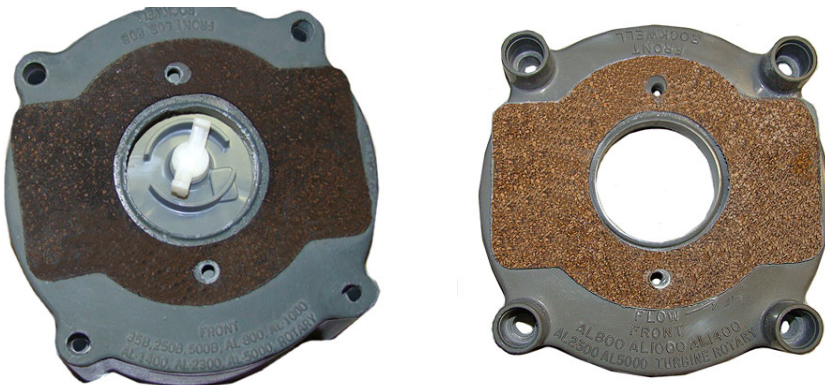

5. Install four mounting screws included with the ERT module and tighten them in an alternating diagonal sequence. For metal mounting plates with a flat screw surface, use ERT module mounting screws with internal tooth washers. For plastic mounting plates with tamper screw cups, use ERT module mounting screws (use O-ring AS-568A-011, 5/16" ID x 7/16-inch OD for a maximum moisture seal). Turn each screw 1/4 to 1/2 turn after it contacts the mounting plate. If you have access to a torque driver, tighten mounting screws to 20-25 inch-pounds.



6. Place new tamper seals over screws (if the mounting plate has tamper seal cups). Press the tamper seals into place with an 11/32-inch nut driver or a similar blunt tool.

To attach the index and cover assembly on the meter and ERT module





1. Place the mounting plate gasket (previously removed) on the index cover mounting plate. Align the gasket and index cover mounting plate screw holes.
2. Place the index and cover assembly on the index mounting plate. (The index must face the direction it faced before removal.) Attach the index/cover assembly on the mounting plate using original 1/2-inch index screws.
 - Insert one screw and tighten two turns to hold it in place on the mounting plate.
 - Insert the second mounting screw and tighten until secure.
 - Completely tighten the first mounting screw.Tighten each index cover mounting screw.
3. Install new tamper or wire seals. If tamper seals are installed, press into place with an 11/32-inch nut driver or similar blunt tool. Crimp the seal if utility-approved wire seals are installed.





This completes installation of the commercial gas ERT module on an Elster American Meter commercial meter.



Attaching the Commercial 100G Gas ERT Module to an Itron Commercial Meter

This section provides instructions for installing the 100G on the Itron, Sprague, Actaris, or Schlumberger 675A, 800A, and 1000A commercial meter. Installation requires an Itron adapter kit available from Itron, Owenton, KY.

Itron Adapter Kit Materials (Part Number 80005901-001)		Itron Part Number (Kit Component)
Adapter plate		550418-001
ERT mounting screws (4)		550416
Adapter plate mounting screws (2)		550622
Screw bushings (4)		550420

Itron Adapter Kit Materials (Part Number 80005901-001)		Itron Part Number (Kit Component)
Tamper seals		017167
Extension driver		550417
Optional Installation Materials (available from Itron)		Itron Part Number
Index cover		80006001
Commercial index		Various
Index mounting screws dial index odometer index		010040 090071

To remove the index cover

1. Place a slotted screwdriver over one of the red security seal covering the index cover mounting screws.
2. Push on the handle-end of the screwdriver to drive the slotted end into the security seal.
3. Pry the broken security seal out of the index screw mounting cup. Be careful not to damage the index cover. Remove the second security seal.

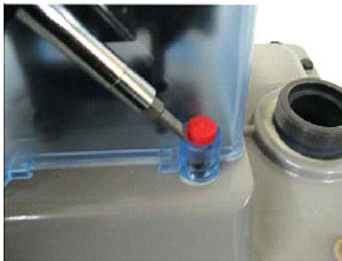

4. Remove the index cover mounting screws with the slotted screwdriver.
5. The index cover has either a room temperature vulcanizing (RTV) or cork gasket. Carefully remove the index cover and inspect the cover for wear or damage to the RTV (silicone) or cork gasket.

Caution If the RTV silicone gasket is damaged during removal or shows signs of degradation, you must replace it with a new index cover from Itron.

6. Set the index cover aside. The index will be reinstalled later in the installation.

To remove the index and index mounting bracket

1. Remove the two screws holding the index bracket to the meter.

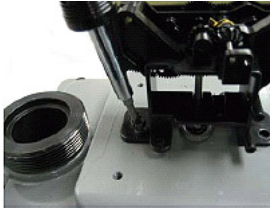

2. To remove a dial index, loosen the two screws holding the index to the index bracket in an alternating pattern:
 - Loosen the right index mounting screw two turns.
 - Loosen the left index mounting screw two turns.
 - Loosen the right and left index mounting screws until you can slide the index to the left and away from the index mounting screws and bracket.

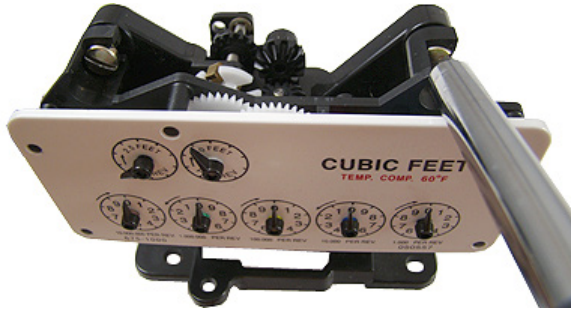

3. To remove an odometer index, remove the two screws holding the index to the index bracket. Temporarily store the index and index mounting screws in a safe location.

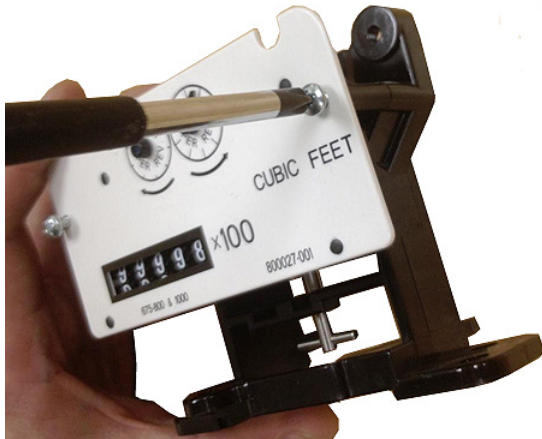

To install the index on the index mounting bracket

1. If the original dial index mounting screws cannot be reused, remove them from the index mounting bracket and recycle or discard.

2. Insert the dial index mounting screws (part number 010040) in the index mounting bracket. Tighten the index mounting screws just enough to secure them in the index mounting bracket.

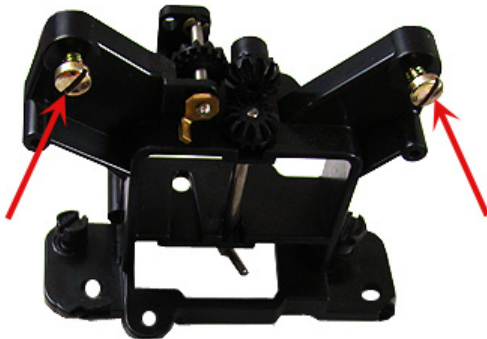

3. Slide the index mounting legs (1) all the way to the right over the index screws. *The mounting bracket drive dog must engage with the index wriggler (2).*

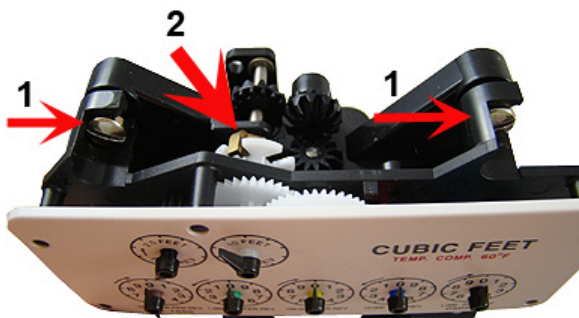

Warning Failure to properly engage the mounting bracket drive dog and index wriggler may cause binding and meter failure.

4. Tighten the index mounting screws in an alternating pattern.



Warning Verify the index is correctly positioned all the way to the right on the index mounting screws before you tighten the index mounting screws. Failure to properly mount the index on the index mounting screws may cause binding and meter failure.

5. Tighten (torque) the index mounting screws to 3 - 6 inch-pounds.

To install the index on the index mounting bracket

1. If the original odometer index mounting screws cannot be reused, recycle or discard them. Use new odometer index mounting screws (part number 090071).

2. Align the mounting bracket drive dog with the index wriggler.

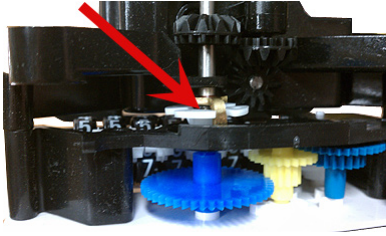

Warning Failure to properly engage the mounting bracket drive dog and index wriggler may cause binding and meter failure.

3. Insert the odometer index mounting screws through the index mounting hole and into the mounting bracket.



4. Tighten the index mounting screws in an alternating pattern. Tighten (torque) the index mounting screws to 3 - 6 inch-pounds.

Programming the Commercial Gas ERT Module Assembly

Program commercial **100G**, **100G DL**, **100G DLN**, or **100G DLT** ERT modules using:

- An FC200SR handheld computer with Field Deployment Manager (FDM) software version 1.1 or higher
or
- A FC300 with SRead handheld computer with Field Deployment Manager (FDM) software version 1.1 or higher
or
- A 900MHz Belt Clip Radio with Field Deployment Manager (FDM) software version 1.1 or higher and a customer-supplied laptop. The Belt Clip Radio connects to the user-supplied laptop using a USB cable or Bluetooth.

The **100G DLS ERT** modules support enhanced security with the Itron Security Manager. Enabling command or enhanced security requires additional programming. Program the 100G DLS ERT modules using:

- An FC200SR handheld computer with Field Deployment Manager (FDM) software version 3.3 or higher
or
- An FC300 with SRead handheld computer with Field Deployment Manager (FDM) software version 3.3 or higher
or
- A 900MHz Belt Clip Radio with Field Deployment Manager (FDM) software version 3.3 or higher and a customer-supplied laptop. The Belt Clip Radio connects to the user-supplied laptop using a USB cable or Bluetooth.

To enable enhanced security and for more complete programming information, see the *Field Deployment Manager Endpoint Tools Mobile Application Guide* (TDC-0934).



FC200SR

FC300 with SRead

900MHz Belt Clip Radio



Caution You must program the 100G ERT module before use.

Take note of the index drive rate shown on the index. The ERT is programmed based on the drive rate. The index shown has a 10-cubic foot drive rate.

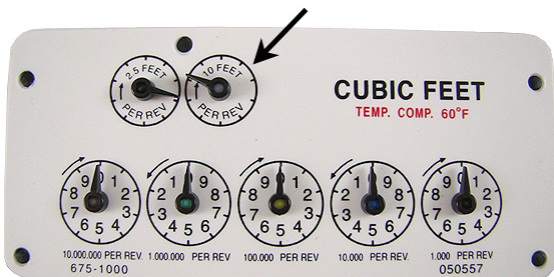

To program the commercial ERT module

1. Program the index drive rate into the 100G series gas ERT module using the endpoint programming device.
2. For all programming and *Check Endpoint* operations, hold the handheld as close to vertical as possible. For best success, keep the handheld programmer within 6 feet of the target ERT module.
3. Verify you have the correct programming mode (Fixed Network Mode, Mobile High Power Mode, Mobile/Handheld Mode, or Hard to Read Mobile/Handheld Mode) for your application. Programming parameters are based on the configuration file loaded into the endpoint programming device.
4. During programming, the 100G is set to the nearest 100 cubic feet; the last two digits (tens and units) are programmed as zeros (0). After programming is complete, the ERT module assembly will read to the nearest cubic foot.

Attaching the Commercial 100G Gas ERT Module Assembly on the Commercial Meter

After you program the commercial gas ERT module, attach it to the commercial meter.

To attach the commercial gas ERT module to the meter

1. Turn the commercial gas ERT module over and place the four mounting screw bushings into the screw holes on the module.



Warning Handle the 100G carefully so the metal passive radiator antenna is not damaged.

2. Push the screw bushings all the way into the mounting screw holes to secure the screw bushings in the mounting screw hole and prevent them from falling out when the module is turned to install on the meter.
3. Turn the ERT module on its side and align the module's wiggler with the meter's drive dog.

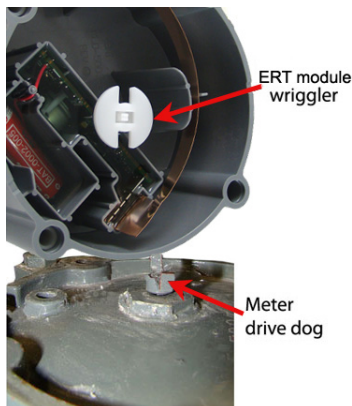

Warning Failure to properly align the 100G DLS wiggler with the meter drive post can cause binding and lead to poor registration or meter failure.

4. Inlet lettering on the commercial gas ERT module must line up with Inlet lettering on the meter.



5. Slowly lower the module onto the Itron commercial meter. Carefully align the meter drive dog and commercial ERT module wiggler. The ERT housing should rest on the top of the meter without gaps.

Warning Do not press down on the 100G if a gap exists between the ERT and the meter. A gap may be caused by misalignment of the ERT wiggler and meter wiggler's drive teeth. Pushing down on the ERT could damage the ERT wiggler or meter drive teeth. To eliminate a gap, remove the 100G and repeat steps 2 and 3.



To mount the index assembly on the adapter plate

1. Align the back outer index bracket screw holes with the adapter plate mounting holes.



2. Secure the index assembly to the adapter plate with the two 1/4-20 x 0.375 Fillister-head screws. Torque the index bracket mounting screws to 3 - 6 inch-pounds.

Note After assembly, the index will be centered on the adapter plate.

To install the index and cover assembly on the commercial module

1. Place the extension driver on the commercial module wriggler. Apply a little pressure to ensure the extension driver seats securely on the commercial module wriggler.

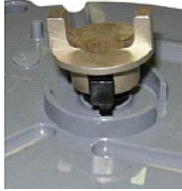

2. Place the Itron adapter plate on the commercial gas module with the two small screw holes in the adapter plate to the back of the meter.

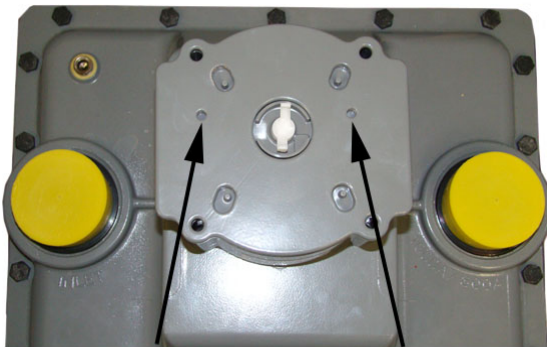

Front of Meter

Note The illustration shows the adapter plate without the index mounting bracket assembly or the extension driver to illustrate the location of the small screw holes. Install the index mounting bracket assembly before you place the adapter plate on the commercial module.

3. Carefully place the adapter plate index assembly on the commercial module and extension driver assembly. The extension driver (1) must align with the index drive dog (2).

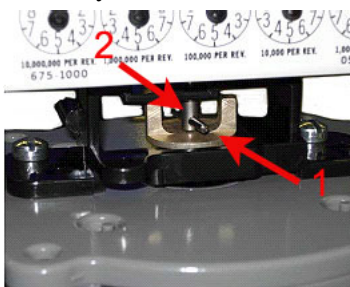

4. Place the index cover over the index with the clear side covering the index dials for easy reading. Align the holes in the index cover with the adapter plate mounting holes.

5. Secure with the four mounting screws from the adapter kit. Tighten the mounting screws in a diagonal alternating pattern.
 - Insert the first screw and tighten enough to hold the index in place.
 - Insert the second screw and tighten two to three turns.
 - Insert the third mounting screw and tighten two to three turns.
 - Insert the fourth mounting screw and tighten.



6. Tighten the first, third and second screw using an alternating tightening pattern. Turn each screw 1/4 to 1/2 turn after the screw contacts the index cover. Tighten each index mounting screw evenly. If you have access to a torque-driver, tighten mounting screws to 20 to 25-inch pounds.
7. Insert tamper seals in the tamper seal cups on the index cover and press into place with an 11/32 nut driver or similar blunt tool.



This completes installation of the commercial AMR module on the Itron commercial meter.



CHAPTER 7

Sensus Commercial Meter Installation

This chapter provides instructions to install the commercial gas ERT module on a Sensus commercial diaphragm meter.



Note Sensus meters are also known as Invensys or Rockwell meters. For these instructions, all meter types are referred to as Sensus meters.



Warning Handle the commercial gas ERT module carefully so the metal passive radiator antenna is not damaged.



Removing the Index or Index Assembly from the Meter

100G commercial gas ERT modules can be mounted on Sensus commercial meters in various configurations. These instructions show the index assembly mounted without a mounting plate.



Note Sensus diaphragm commercial meters do not require an index assembly mounting plate. Indexes can be mounted directly to the ERT module.

To remove the index from the meter

1. Remove any tamper seals (or wire seals) from the index cover and remove the index cover mounting screws. You will reinstall it later in these instructions.

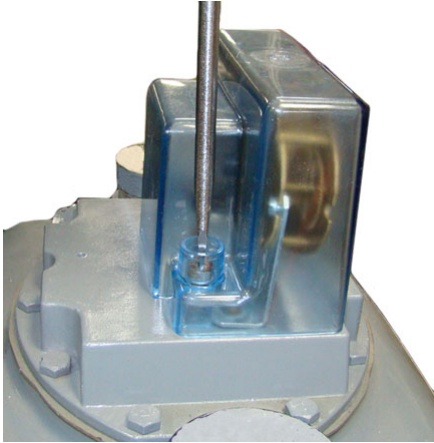

2. Remove the index screws from the meter. Set the index cover aside where it will not be damaged or fill with dirt, rain or snow. You will re-install the index later in this procedure.

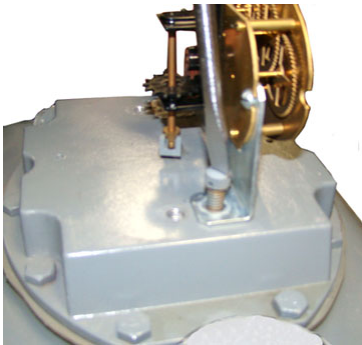

Note Properly dispose all unused screws, old index covers, gaskets, tamper seals, and other leftover materials. Do not leave materials on customer premises.

Programming the Commercial Gas ERT Module Assembly

Program commercial **100G, 100G Datalogging, 100G DLN, or 100G DLT** ERT modules using:

- An FC200SR handheld computer with Field Deployment Manager (FDM) software version 1.1 or higher
or
- A FC300 with SRead handheld computer with Field Deployment Manager (FDM) software version 1.1 or higher
or
- A 900MHz Belt Clip Radio with Field Deployment Manager (FDM) software version 1.1 or higher and a customer-supplied laptop. The Belt Clip Radio connects to the user-supplied laptop using a USB cable or Bluetooth.

Sensus Commercial Meter Installation

The **100G DLS ERT** modules support enhanced security with the Itron Security Manager. Enabling command or enhanced security requires additional programming. Program the 100G DLS ERT modules using:

- An FC200SR handheld computer with Field Deployment Manager (FDM) software version 3.3 or higher
or
- An FC300 with SRead handheld computer with Field Deployment Manager (FDM) software version 3.3 or higher
or
- A 900MHz Belt Clip Radio with Field Deployment Manager (FDM) software version 3.3 or higher and a customer-supplied laptop. The Belt Clip Radio connects to the user-supplied laptop using a USB cable or Bluetooth.

To enable enhanced security and for more complete programming information, see the *Field Deployment Manager Endpoint Tools Mobile Application Guide* (TDC-0934).



FC200SR

FC300 with SRead

900MHz Belt Clip Radio



Caution You must program the 100G commercial ERT module before use.

Take note of the index drive rate shown on the index. The ERT is programmed based on the drive rate. Sensus commercial meter index drive rates may be 5-, 10- or 100-cubic feet. The seven-dial index shown is a 100-cubic feet drive rate.



To program the commercial ERT module

Program the index drive rate into the commercial ERT module using the endpoint programming device. For all programming and *Check Endpoint* operations, hold the handheld programmer as close to vertical as possible. For best success, keep the handheld programmer within 6 feet of the target ERT module. Verify you have the correct programming mode (Fixed Network Mode, Mobile High Power Mode, Mobile/Handheld Mode, or Hard to Read Mobile/Handheld Mode) for your application. Programming parameters are based on the configuration file loaded into the endpoint programming device.

During programming, the ERT module is set to the nearest 100 cubic feet; the last two digits (tens and units) are programmed as zeros (0). After programming is complete, the ERT module assembly will read to the nearest cubic foot.

Installing the Commercial ERT Module Assembly to the Meter

After the ERT module is programmed, complete the ERT module installation by installing the commercial module to the commercial meter.



Warning Handle the commercial gas ERT module carefully so the metal passive radiator antenna is not damaged.



To install the commercial ERT module on the Sensus commercial meter

1. Tilt the commercial ERT module at an angle and turn the wiggler until the drive notches line up with the meter wiggler's drive teeth.

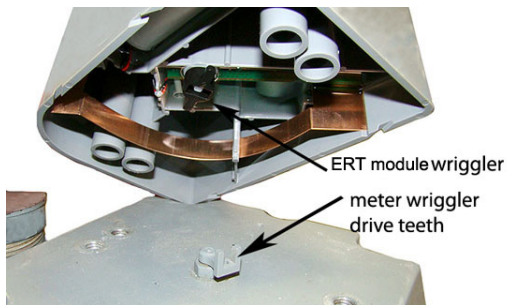

Warning Failure to properly align the 100G DLS wiggler with the meter drive post can cause binding and lead to poor registration or meter failure.

Sensus Commercial Meter Installation

- Align the ERT module so the screw holes line up with the meter's top screw holes. Carefully lower the ERT on the meter so the wriggler's bars line up with the meter drive dog. Itron recommends installation with one bar inserted into the meter drive dog's u-shaped gear.

Warning The INLET label on the commercial gas ERT module must line up with the INLET label on the Sensus meter case.

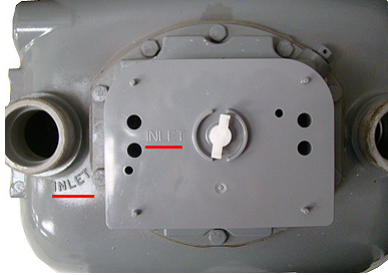

- Verify the bottom of the ERT module and the top of the meter meet. The ERT housing should rest on top of the meter without gaps.

Warning Do not press down on the commercial ERT module if a gap exists between the ERT and the meter. A gap may be caused by misalignment of the ERT wriggler and meter's drive teeth. Pushing down on the ERT could damage the ERT wriggler or meter drive teeth. To eliminate a gap, slowly turn the commercial gas ERT module's shaft back and forth until the ERT module wriggler aligns with the meter's drive teeth.



- Align the ERT module with the index mounting holes. Verify the index drive dog intersects with the ERT module's wriggler.
- Install the ERT mounting screws (SCR-0062-003, see [Installation Prerequisites](#) on page 14 for screw information). Turn each screw 1/4 to 1/2 turn after it contacts the index assembly.

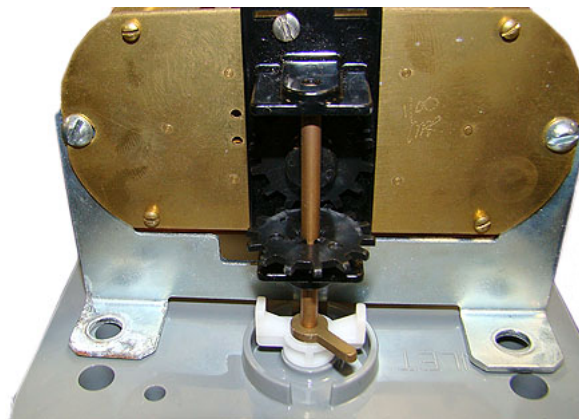

- Install the index cover.
 - For index covers with flat-surface screw holes, use screws (SCR-0062-002), flat washers (WSH-0020-005), and cork washers (WSH-0032-001).

Sensus Commercial Meter Installation

- For index covers with tamper seal cups, use screws, (AS-568A-011, 5/16" ID x 7/16 OD) O-rings, and tamper seals.

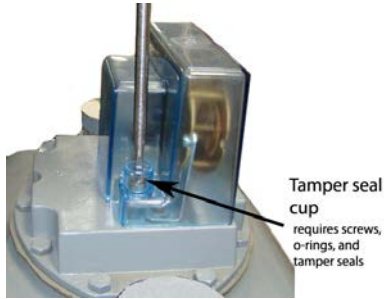

7. Place new tamper seals over screws (if mounting plate has tamper seal cups) and press into place with an 11/32-inch nut driver or similar blunt tool.
8. If your mounting assembly requires a utility-approved wire seal, pass wires through holes in the screw heads and crimp the approved wire seal.

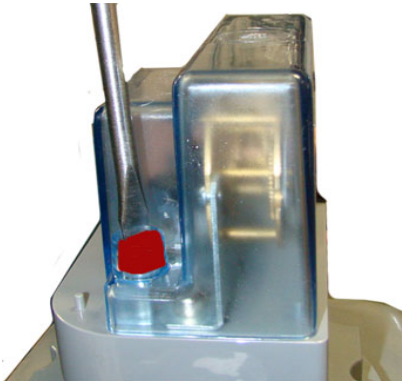

This completes installation of the 100G commercial gas ERT module on the Sensus commercial diaphragm meter.



Mounting a 100G Gas ERT Module on a Rockwell 750 meter with an Aluminum BOX Direct Reading (VDR)

Installing the 100G series commercial gas ERT module on a Rockwell commercial meter with an aluminum box direct reading (VDR) index requires two Itron SCR-0062-001 mounting screws (see [Installation Prerequisites](#) on page 14). The mounting screws must be purchased separately.

To remove the index from the meter

1. Remove tamper seals and screws from the top of the aluminum box direct reading index. Set the cover and screws aside. You will use them later in the installation.



2. Remove the screws holding the aluminum box to the meter.

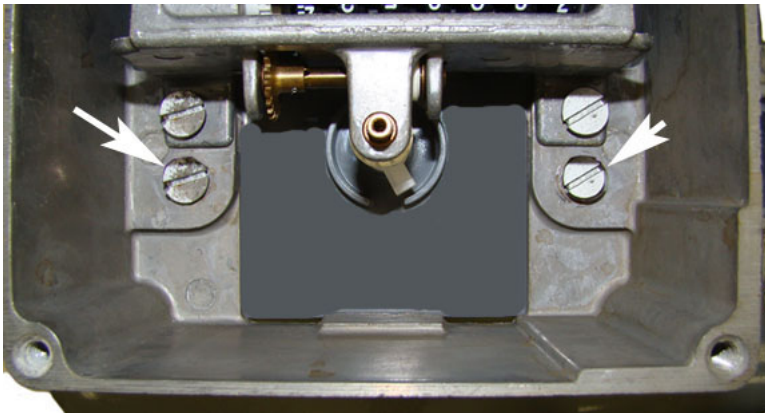

3. Carefully remove the aluminum box and set it aside. You will use it later in this installation.

Program the commercial gas ERT before you install it on the Rockwell meter (see [Programming the Commercial 100G Gas ERT Module Assembly](#) on page 60).

Installing the Commercial ERT Module Assembly to the Meter

After the ERT module is programmed, complete the ERT module installation by installing the commercial module to the commercial meter.

 **Warning** Handle the commercial gas ERT module carefully so the metal passive radiator antenna is not damaged.



To install the commercial ERT module on a Rockwell meter with an aluminum box direct reading (VDR) index

1. Using a side-cutter, remove the two rear housing pins from the 100G commercial ERT module.



Caution Removing the rear housing pins may make the ERT module incompatible with other commercial meters.

2. Tilt the ERT module at an angle and turn the wiggler until the drive notches line up with the meter wiggler's drive teeth.

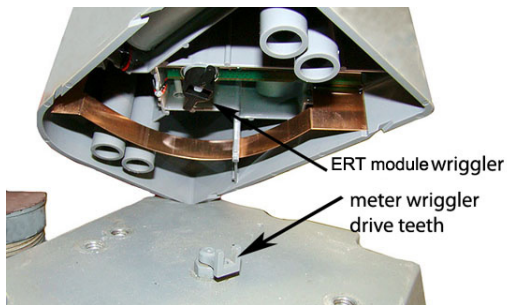

Warning Failure to properly align the 100G ERT module wiggler with the meter drive post can cause binding and lead to poor registration or meter failure.

Sensus Commercial Meter Installation

- Align the ERT module so the screw holes line up with the meter's top screw holes. Carefully lower the ERT on the meter so the wriggler's bars line up with the meter drive dog. Itron recommends installation with one bar inserted into the meter drive dog's u-shaped gear.

Warning The INLET label on the commercial gas ERT must line up with the INLET label on the Rockwell meter case.

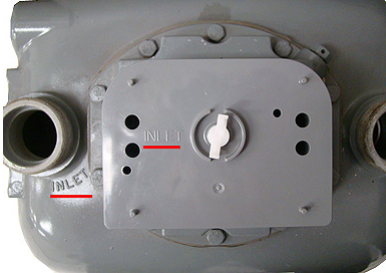

- Verify the bottom of the commercial gas ERT module and the top of the meter meet. The ERT housing must rest on top of the meter without gaps.

Warning Do not press down on the ERT module if a gap exists between the ERT and the meter. A gap may be caused by misalignment of the ERT wriggler and meter's drive teeth. Pushing down on the ERT could damage the ERT wriggler or meter drive teeth. To eliminate a gap, slowly turn the ERT module's shaft back and forth until the ERT wriggler aligns with the meter's drive teeth.



- Align the index drive wriggler with the ERT module shaft and mounting holes. Attach the ERT module to the meter using two SCR-0062-001 Itron mounting screws.



- Attach the index cover with the original index cover screws.
- Insert tamper seals in the tamper seal cups. Push tamper seals into place using an 11/32-inch nut driver or similar blunt tool.

Sensus Commercial Meter Installation

This completes installation of the 100G commercial ERT module with an aluminum box direct reading (VDR) index on a Rockwell commercial meter.



GE Oil & Gas Dresser Commercial Rotary Meter Installation

This chapter provides the instructions to mount 100G ERT modules (residential and commercial) on GE Dresser commercial rotary meters.

Some commercial AMR applications require a GE Dresser rotary meter with a residential 100G ERT module. Only Elster American version residential 100G ERT modules are compatible with GE Dresser series rotary gas meters. This chapter provides the instructions to mount an Elster American residential 100G ERT module on GE Dresser AMR-ready rotary commercial meters. Installation requires an AMR adapter kit supplied by GE Dresser. Refer to the [100G Gas ERT Module Meter Compatibility List](#) for GE Dresser AMR adapter kit part numbers.

Installation Prerequisites

Materials Supplied By Itron

- 100G ERT module
- New tamper seals, if applicable

Materials Supplied by You

- AMR-ready GE Dresser Rotary Meter
- Adapter Kit from GE Dresser
- Elster American Meter index if mounting to 5C15 or 8C15 Rotary Meter



Note Follow the manufacturer field installation instructions to modify the AMR-ready GE Dresser Meter for 100G installation. Contact a GE Dresser distributor or GE Dresser representative for installation instructions specific to the required AMR adapter kit.

Installation Examples

The following pictures show typical residential 100G installations.

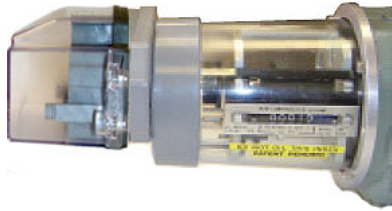

GE Dresser B3 CTR/TC

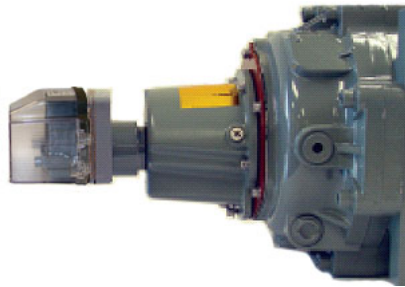

GE Dresser LMMA CTR

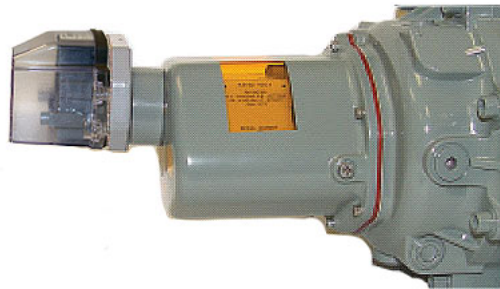

GE Dresser LMMA TC



GE Dresser 8C15

Programming the 100G Gas ERT Module Assembly

Program the **100G**, **100G Datalogging**, **100G DLN**, or **100G DLT** ERT modules using:

- An FC200SR handheld computer with Field Deployment Manager (FDM) software version 1.1 or higher
or
- A FC300 with SRead handheld computer with Field Deployment Manager (FDM) software version 1.1 or higher
or
- A 900MHz Belt Clip Radio with Field Deployment Manager (FDM) software version 1.1 or higher and a customer-supplied laptop. The Belt Clip Radio connects to the user-supplied laptop using a USB cable or Bluetooth.

The **100G DLS ERT** modules support enhanced security with the Itron Security Manager. Enabling command or enhanced security requires additional programming. Program the 100G DLS ERT modules using:

- An FC200SR handheld computer with Field Deployment Manager (FDM) software version 3.3 or higher
or
- An FC300 with SRead handheld computer with Field Deployment Manager (FDM) software version 3.3 or higher
or
- A 900MHz Belt Clip Radio with Field Deployment Manager (FDM) software version 3.3 or higher and a customer-supplied laptop. The Belt Clip Radio connects to the user-supplied laptop using a USB cable or Bluetooth.

To enable enhanced security and for more complete programming information, see the *Field Deployment Manager Endpoint Tools Mobile Application Guide* (TDC-0934).



FC200SR

FC300 with SRead

900MHz Belt Clip Radio



Caution You must program the 100G ERT module before use.

For 5C15 and 8C15 Rotary Meters, program as 4 dial, 2 cubic foot index. For all other residential 100G series gas ERT modules, refer to [B3, LMMA, and S3A CTR/TC GE Dresser Series Register Settings and Direct Drive Programming Information](#) on page 88.

To program the 100G ERT module

Program the meter drive rate into the commercial ERT module using the endpoint programming device. For all programming and *Check Endpoint* operations, hold the handheld programmer as close to vertical as possible. For best success, keep the handheld programmer within 6 feet of the target ERT module. Verify you have the correct programming mode (Fixed Network Mode, Mobile/Handheld Mode, or Hard to Read Mobile/Handheld Mode) for your application. Programming parameters are based on the configuration file loaded into the endpoint programming device.

During programming, the commercial ERT module is set to the nearest 100 cubic feet; the last two digits (tens and units) are programmed as zeros (0). After programming is complete, the ERT module assembly will read to the nearest cubic foot.

B3, LMMA, and S3A CTR/TC GE Dresser Series Register Settings and Direct Drive Programming Information

Use the information in the following tables to program GE Dresser Series B3, LMMA, and S3A non-compensated counter (CTR) and temperature compensated (TC) registers. Reference the [100G Gas ERT Module Meter Compatibility List](#) to confirm compatibility.

Settings for Series B3 Registers			Settings for LMMA Registers		
Model	Meter size	Settings	Model	Meter Size	Settings
CTR	8C-15C and 2M-11M	Number of dials: 5 Drive rate: 10 PCOMP factor: NONE	CTR	1.5M-11M	Number of dials: 5 Drive rate: 10 PCOMP factor: NONE
	16M-56M	Number of dials: 6 Drive rate: 100 PCOMP factor: NONE		16M	Number of dials: 6 Drive rate: 100 PCOMP factor: NONE
TC	8C-15C and 2M-11M	Number of dials: 5 Drive rate: 100 PCOMP factor: NONE	TC	1.5M-11M	Number of dials: 5 Drive rate: 50 PCOMP factor: NONE
	16M	Number of dials: 6 Drive rate: 1000 PCOMP factor: NONE		16M	Number of dials: 6 Drive rate: 500 PCOMP factor: NONE

Settings for Series S3A Registers		
Model	Meter Size	Settings
CTR	1.5M - 11M	Number of dials: 5 Drive rate: 10 PCOMP factor: NONE
	16M	Number of dials: 6 Drive rate: 100 PCOMP factor: NONE
TC	1.5M - 11M	Number of dials: 5 Drive rate: 100 PCOMP factor: NONE
	16M	Number of dials: 6 Drive rate: 1000 PCOMP factor: NONE

B3, LMMA and S3A CTR/TC Meter Drive Rates: Residential Direct Drive Programming*

B3 CTR Meter Size	B3 CTR Meter Drive Rate	B3 TC Meter Size	B3 TC Meter Drive Rate
8C	10	8C	100
11C	10	11C	100
15C	10	15C	100
2M	10	2M	100
3M	10	3M	100
5M	10	5M	100
7M	10	7M	100
11M	10	11M	100
16M	100	16M	1000
23M	100		
38M	100		
56M	100		

LMMA CTR Meter Size	LMMA CTR Meter Drive Rate	LMMA TC Meter Size	LMMA TC Meter Drive Rate
1.5M	10	1.5M	50
3M	10	3M	50
5M	10	5M	50
7M	10	7M	50
11M	10	11M	50
16M	100	16M	500

S3A CTR Meter Size	S3A CTR Meter Drive Rate	S3A TC Meter Size	S3A TC Meter Drive Rate
1.5M	10	1.5M	100
3M	10	3M	100
5M	10	5M	100
7M	10	7M	100
11M	10	11M	100
16M	100	16M	1000



Caution Drive rates in these tables are for direct-mount residential style ERTs only (NOT commercial or remote ERT modules).



Note S3A rotary meters are LMMA meters retrofitted with a Series 3 accessory.

Installing the Residential ERT Module Assembly to the GE Dresser Rotary Meter

After the 100G ERT module programming is complete, attach the ERT assembly to the GE Dresser Rotary Meter. This mounting procedure applies to B3 CTR/TC, LMMA CTR/TC, and 8C15 series GE Dresser Meters.

To install the 100G on the GE Dresser Adapter

Refer to the [Installation Examples](#) on page 86.

- The 100G series ERT module must be mounted on the adapter plate in an upright position. Align the module wiggler with the opening between the tabs of the adapter's drive dog.
 - Insert one module mounting screw and tighten enough to hold the module. Do not completely tighten the screw.
 - Insert the second mounting screw and tighten it two turns.
 - Insert the third mounting screw and tighten it two turns.
 - Insert the last mounting screw and tighten it until snug. Tighten the remaining mounting screws in an alternating, diagonal pattern until snug. Tighten all mounting screws evenly.



Warning A gap may be caused by misalignment of the ERT module wiggler and adapter's drive teeth. Pushing down on the ERT module could damage the ERT module wiggler or adapter's drive teeth. To eliminate a gap, remove the ERT module assembly and re-align the ERT wiggler with the adapter's drive teeth.

- Complete necessary paperwork and verify all excess materials are removed from the customer's premises. Residential 100G ERT module installation on the GE Dresser Rotary meter is complete.

Installing the Commercial Gas ERT Module Assembly on a GE Dresser Rotary Meter with an Instrument Drive

The information in this section guides you through the installation of the commercial gas ERT on GE Dresser rotary meters.



Note This installation procedure requires a GE Dresser rotary gas meter with an instrument drive. These instructions show an Elster American commercial ERT module. The installation procedure is identical for the Sensus commercial ERT module.

100G Elster American Commercial Gas ERT Module



100G Sensus Commercial Gas ERT Module



Installation requires the following items:

- One index mounting plate (if applicable)
- Gasket and drive cover kit (if applicable)
- An Elster American Meter or Sensus commercial ERT module
- A flat, slot-drive screwdriver

Programming the Commercial Gas ERT Module

Program **100G**, **100G DL**, **100G DLN**, or **100G DLT** commercial ERT modules using:

- An FC200SR handheld computer with Field Deployment Manager (FDM) software version 1.1 or higher
or
- A FC300 with SRead handheld computer with Field Deployment Manager (FDM) software version 1.1 or higher
or
- A 900MHz Belt Clip Radio with Field Deployment Manager (FDM) software version 1.1 or higher and a customer-supplied laptop. The Belt Clip Radio connects to the user-supplied laptop using a USB cable or Bluetooth.

The **100G DLS ERT** modules support enhanced security with the Itron Security Manager. Enabling command or enhanced security requires additional programming. Program the 100G DLS ERT modules using:

- An FC200SR handheld computer with Field Deployment Manager (FDM) software version 3.3 or higher
or
- An FC300 with SRead handheld computer with Field Deployment Manager (FDM) software version 3.3 or higher
or
- A 900MHz Belt Clip Radio with Field Deployment Manager (FDM) software version 3.3 or higher and a customer-supplied laptop. The Belt Clip Radio connects to the user-supplied laptop using a USB cable or Bluetooth.

To enable enhanced security and for more complete programming information, see the *Field Deployment Manager Endpoint Tools Mobile Application Guide* (TDC-0934).



Caution You must program the 100G ERT module before use.

The ERT module is programmed based on the meter's drive rate. See B3, LMMA, and S3A CD/TD GE Dresser Meter Drive Rates.

Program the meter drive rate into the 100G commercial gas ERT module using the endpoint programming device. For all programming and Check Endpoint operations, hold the handheld programmer as close to vertical as possible. For best success, keep the handheld programmer within 6 feet of the target ERT module. Verify you have the correct programming mode (Fixed Network Mode, Mobile/Handheld Mode, or Hard to Read Mobile/Handheld Mode) for your application. Programming parameters are based on the configuration file loaded into the endpoint programming device.

During programming, the 100G Datalogging FN commercial gas ERT module is set to the nearest 100 cubic feet; the last two digits (tens and units) are programmed as zeros (0). After programming is complete, the ERT module assembly will read to the nearest cubic foot.

B3, LMMA, and S3A CD/TD GE Dresser Meter Drive Rates

Use the information in the following tables to program the commercial ERT modules installed on GE Dresser B3, LMMA, and S3A registers. Reference the [100G Gas ERT Module Meter Compatibility List](#) to confirm compatibility.

 **Warning** Drive rates listed in the following tables are for commercial module programming. Do not use these settings to program residential or remote modules.

B3 CD Meter Size	B3 CD Meter Drive Rates	B3 TD Meter Size	B3 TD Meter Drive Rate
8C	10	8C	100
11C	10	11C	100
15C	10	15C	100
2M	10	2M	100
3M	10	3M	100
5M	10	5M	100
7M	10	7M	100
11M	10	11M	100
6M	100	16M	1000
23M	100		
38M	100		
56M	100		

LMMA CD Meter Size	LMMA CD Meter Drive Rate	LMMA TD Meter Size	LMMA TD Meter Drive Rate
1.5M	10	1.5M	100
3M	10	3M	100
5M	10	5M	100
7M	10	7M	100
11M	10	11M	100
16M	100	16M	1000

S3A CD Meter Size	S3A CD Meter Drive Rate	S3A TD Meter Size	S3A TD Meter Drive Rate
1.5M	100	1.5M	100
3M	100	3M	100
5M	100	5M	100
7M	1000	7M	100
11M	100	11M	100

16M	1000	16M	1000
-----	------	-----	------

 **Note** S3A rotary meters are LMMA meters retrofitted with Series 3 accessory.

To install the commercial ERT module to the meter

Note A cover is installed on the commercial gas ERT module mounted to a GE Dresser Meter with S3A LMMA accessory units (or other GE Dresser adapters with odometer gauges).

1. Locate the INSTRUMENT FACE stamp (1) and position the meter with the drive dog (2) centered (as shown).

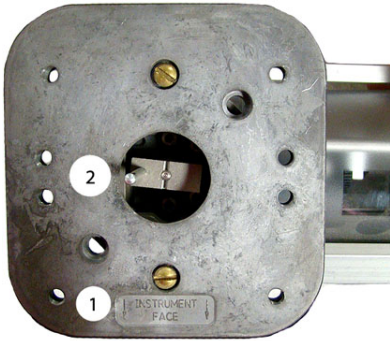

Warning Handle the commercial ERT module carefully so the metal passive radiator antenna is not damaged.

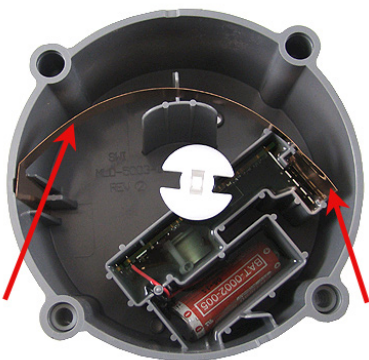

2. Locate the INLET (1) stamp on the ERT and position the ERT as shown in the following illustration. Verify the commercial gas ERT module wiggler (3) and drive dog shaft (2) are aligned (for more information, see [To attach the commercial gas ERT module to the Elster American commercial meter](#) on page 62 or [To attach the commercial ERT on the Sensus commercial meter](#) on page 78).

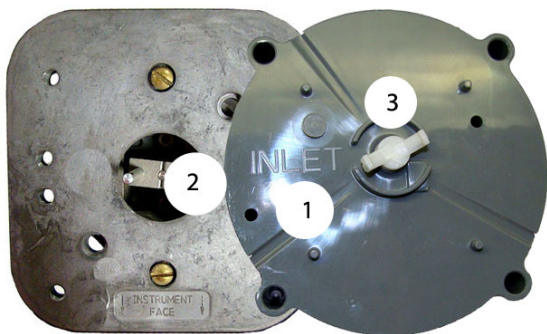

Warning Failure to properly align the 100G ERT module wiggler with the meter drive post can cause binding and lead to poor registration or meter failure.

3. Verify the ERT wiggler and drive dog shaft are engaged by turning the commercial ERT module wiggler. When properly engaged, you will feel resistance.
4. Place the customer-supplied index mounting plate on the ERT and install the four mounting screws. Do not disturb the shaft alignment.

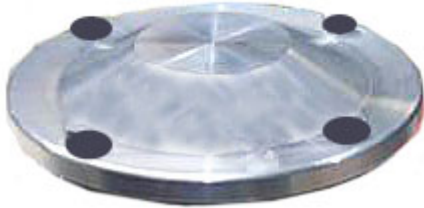

5. Install the four ERT module mounting screws (supplied with the commercial ERT). Tighten mounting screws in an alternating, diagonal pattern. Tighten each ERT module mounting screw evenly.
 - Turn each screw 1/4 to 1/2 turn after it contacts the cover.
 - Torque to 20 - 25 inch-pounds.
6. Insert new utility-approved wire seals and crimp (if required).



Note To mount an index and index cover on a rotary meter without an accessory odometer unit, remove the domed cover and reference [To attach the index and cover assembly on the meter](#) on page 64.

Completed Installation Examples

100G Elster American commercial gas ERT module mounted on a GE Dresser Meter with an instrument drive



100G Sensus commercial gas ERT module mounted on a GE Dresser meter with an instrument drive

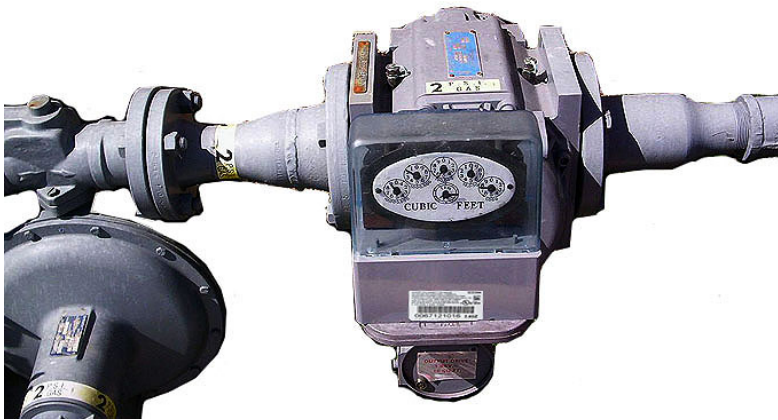

CHAPTER 9

Romet Commercial Rotary Meter Installation

This chapter provides the instructions to mount residential 100G ERT modules on the Romet RM commercial rotary meters.

Only Elster American version residential 100G ERT modules are compatible with Romet RM rotary gas meters. This chapter provides the instructions to mount an Elster American residential 100G ERT module on Romet AMR-ready rotary commercial meters. Installation requires an AMR adapter kit supplied by Romet.

Installation Example

The following illustration shows the typical residential 100G ERT module installation.



Romet STD-RM2000

Programming the 100G Gas ERT Module Assembly

Program the **100G**, **100G Datalogging**, **100G DLN**, or **100G DLT** ERT modules using:

- An FC200SR handheld computer with Field Deployment Manager (FDM) software version 1.1 or higher
or
- A FC300 with SRead handheld computer with Field Deployment Manager (FDM) software version 1.1 or higher
or
- A 900MHz Belt Clip Radio with Field Deployment Manager (FDM) software version 1.1 or higher and a customer-supplied laptop. The Belt Clip Radio connects to the user-supplied laptop using a USB cable or Bluetooth.

Romet Commercial Rotary Meter Installation

The **100G DLS ERT** modules support enhanced security with the Itron Security Manager. Enabling command or enhanced security requires additional programming. Program the 100G DLS ERT modules using:

- An FC200SR handheld computer with Field Deployment Manager (FDM) software version 3.3 or higher
or
- An FC300 with SRead handheld computer with Field Deployment Manager (FDM) software version 3.3 or higher
or
- A 900MHz Belt Clip Radio with Field Deployment Manager (FDM) software version 3.3 or higher and a customer-supplied laptop. The Belt Clip Radio connects to the user-supplied laptop using a USB cable or Bluetooth.

To enable enhanced security and for more complete programming information, see the *Field Deployment Manager Endpoint Tools Mobile Application Guide* (TDC-0934).



FC200SR

FC300 with SRead

900MHz Belt Clip Radio



Caution You must program the 100G ERT module before use.

For 5C15 and 8C15 Rotary Meters, program as 4 dial, 2 cubic foot index. For all other residential 100G series gas ERT modules, refer to [B3, LMMA, and S3A CTR/TC GE Dresser Series Register Settings and Direct Drive Programming Information](#) on page 88.

To program the 100G ERT module

Program the meter drive rate into the commercial ERT module using the endpoint programming device. For all programming and *Check Endpoint* operations, hold the handheld programmer as close to vertical as possible. For best success, keep the handheld programmer within 6 feet of the target ERT module. Verify you have the correct programming mode (Fixed Network Mode, Mobile/Handheld Mode, or Hard to Read Mobile/Handheld Mode) for your application. Programming parameters are based on the configuration file loaded into the endpoint programming device.

During programming, the commercial ERT module is set to the nearest 100 cubic feet; the last two digits (tens and units) are programmed as zeros (0). After programming is complete, the ERT module assembly will read to the nearest cubic foot.

Installing the Residential ERT Module Assembly to the Romet

After the 100G ERT module is programmed, attach the module to the Romet rotary meter.

To attach the ERT module to the Romet rotary meter

Refer to the [Installation Example](#) on page 97. The ERT module must be mounted on the adapter plate in an upright position. Follow the alignment of the mounting components shown in the exploded installation illustration (step 2).

1. Assemble the O-Ring (4) on the meter drive dog.
2. Insert the drive dog (5) into the Romet rotary meter and secure it to the meter using the three flat head screws (11).

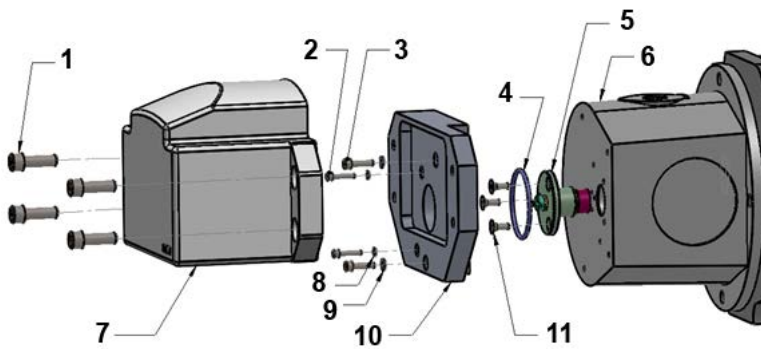

1. Socket head cap screws (4) 1/4-20 x 3/4 lg
 2. Socket head cap screws (2) #4-40 x 1/2 lg
 3. Socket head cap screws (2) #6-32 x 1/2 lg
 4. O-Ring
 5. Drive dog assembly
 6. Romet STD CTR
 7. Itron 100G residential ERT module
 8. Lock washers (4)
 9. Lock washers (6)
 10. Adapter plate
 11. Flat head screws (3) #4-40 x 5/16
3. Mount the adapter plate (10) over the meter drive dog and to the Romet rotary meter using the lock washers (8, 9) and the socket head cap screws (2, 3).
 4. Tighten the adapter plate mounting screws in an alternating pattern.
 5. Align the ERT module wriggler with the meter drive dog (5). Ensure the drive dog aligns with the space between the wriggler's teeth.

Warning A gap may be caused by misalignment of the module wriggler and the meter wriggler's drive teeth. Pushing down on the module could damage the module's wriggler or meter drive teeth. To eliminate a gap, remove the module assembly and re-align the module's wriggler with the meter drive dog.

6. Secure the ERT module to the adapter plate using the four socket head cap screws (1).
7. Complete the necessary paperwork and verify all excess materials are removed from the customer's premises.

Index

Symbols & Numbers

- 100G DLS Gas ERT Module security • 2
- 100G meter compatibility list • 4

A

- about the 100G gas ERT module • 1
- assembling the ERT module and index • 18
- attaching the 100G assembly to the meter • 35, 29, 22, 54
- attaching the 100G assembly to the Sensus meter • 29
- attaching the 100G to the commercial meter • 78, 62
- attaching the 100G to the Sprague 175RM meter • 46

B

- B3, LMMA, and S3A CD/TD Dresser series meter drive rates • 93
- B3, LMMA, and S3A CTR/TC Dresser series register settings and direct drive rates • 88
- before you begin • vii

E

- Elster American and Itron (Actaris) commercial meter installation • 58
- Elster American Meter installation • 17

G

- GE Oil & Gas Dresser commercial rotary meter installation • 85

I

- installation examples • 86
- installation prerequisites • 14
- installing the ERT module assembly to flat-faced Sprague meters • 39
- installing the 100G assembly on Sprague 175RM meters • 42
- installing the 100G on a Rockwell commercial meter with an aluminum box direct reading index • 81
- installing the commercial 100G gas ERT module on an Itron (Actaris) commercial module • 65

- installing the commercial gas ERT on a Dresser Rotary Meter with an instrument drive • 91
- Itron (Sprague) meter installation • 31
- Itron Security Manager • 2

N

- National (Lancaster) meter installation • 49

P

- programming the 100G assembly • 20
- programming the commercial gas ERT • 60, 69

R

- related documents • 3
- removing the index or index assembly from the meter • 58
- removing the meter index • 17

S

- securing brass meter tags to flat-faced meters • 40
- Sensus (Invensys, Equimeter, Rockwell) meter installation • 24
- Sensus (Rockwell) Commercial Meter Installation • 75
- specifications • 3

T

- transmission modes • 1