

TEST REPORT

Report No.: 17120669HKG-002

Application For Original Grant of 47 CFR Part 15 Certification

New Family of RSS-210 Issue 9 Equipment Certification

VoIP Phone

FCC ID: EW780-S006-00

IC: 1135B-80S00600

Prepared and Checked by:

Approved by:

Signed On File

Josie Yao

Engineer

Tang Kwan Mo, Jess

Lead Engineer

Date: April 06, 2018

Intertek's standard Terms and Conditions can be obtained at our website <http://www.intertek.com/terms/>.

This test report only allows to be revised within the retention period unless further standard or the requirement was noticed.

This report is for the exclusive use of Intertek's Client and is provided pursuant to the agreement between Intertek and its Client. Intertek's responsibility and liability are limited to the terms and conditions of the agreement. Intertek assumes no liability to any party, other than to the Client in accordance with the agreement, for any loss, expense or damage occasioned by the use of this report. Only the Client is authorized to permit copying or distribution of this report and then only in its entirety. Any use of the Intertek name or one of its marks for the sale or advertisement of the tested material, product or service must first be approved in writing by Intertek. The observations and test results in this report are relevant only to the sample tested. This report by itself does not imply that the material, product, or service is or has ever been under an Intertek certification program.

© 2017 Intertek

TEST REPORT

GENERAL INFORMATION

Grantee:	VTech Telecommunications Ltd.
Grantee Address:	23/F., Tai Ping Industrial Centre, Block 1, 57 Ting Kok Road, Tai Po, Hong Kong.
FCC Specification Standard:	FCC Part 15, October 1, 2016 Edition
FCC ID:	EW780-S006-00
FCC Model(s):	D785 / ET685 / X885
IC Specification Standard:	RSS-210 Issue 9, August 2016 RSS-Gen Issue 4, November 2014
IC:	1135B-80S00600
HVIN	D785 / ET685 / X885
PMN	VoIP phone for D785, ErisTerminal SIP Deskset for ET685, SIP Color Deskset For X885
Type of EUT:	Transceiver
Description of EUT:	VoIP Phone
Serial Number:	N/A
Sample Receipt Date:	December 18, 2017
Date of Test:	December 18, 2017 to April 05, 2018
Report Date:	April 06, 2018
Environmental Conditions:	Temperature: +10 to 40°C Humidity: 10 to 90%

TEST REPORT

TABLE OF CONTENTS

1.0	TEST RESULTS SUMMARY & STATEMENT OF COMPLIANCE	4
1.1	Summary of Test Results	4
1.2	Statement of Compliance	4
2.0	GENERAL DESCRIPTION	5
2.1	Product Description	5
2.2	Test Methodology	5
2.3	Test Facility	5
3.0	SYSTEM TEST CONFIGURATION	6
3.1	Justification	6
3.2	EUT Exercising Software	7
3.3	Radiated Emission Test Setup	8
3.4	Conducted Emission Test Setup	9
3.5	Details of EUT and Description of Accessories	10
3.6	Measurement Uncertainty	10
4.0	TEST RESULTS	11
4.1	Field Strength Calculation	11
4.2	Radiated Emissions	12
4.2.1	Radiated Emission Configuration Photograph	12
4.2.2	Radiated Emission Data	12
4.2.3	Transmitter Duty Cycle Calculation	17
4.3	Radiated Emission on the Bandedge	19
4.4	AC Power Line Conducted Emission	22
4.4.1	AC Power Line Conducted Emission Configuration Photograph	22
4.4.2	AC Power Line Conducted Emission Data	22
4.5	Occupied Bandwidth	25
5.0	EQUIPMENT LIST	26

TEST REPORT

1.0 TEST RESULTS SUMMARY & STATEMENT OF COMPLIANCE

1.1 Summary of Test Results

Test Items	FCC Part 15 Section	RSS-210/ RSS-Gen [#] / RSS-310 [^] Section	Results	Details See Section
Antenna Requirement	15.203	8.3 [#]	Pass	2.1
Security Code Information	15.214(d)	2.4	Pass	2.1
Radiated Emission	15.249(a), 209, & 109	A2.9(a)	Pass	4.2
Radiated Emission on the Bandedge	15.249(d)	A2.9(b)	Pass	4.3
Radiated Emission in Restricted Bands	15.205	2.2	Pass	4.2
AC Power Line Conducted Emission	15.207 & 15.107	8.8 [#]	Pass	4.4

Note: Pursuant to FCC Part 15 Section 15.215(c), the 20dB bandwidth of the emission was contained within the frequency band designated (mentioned as above) which the EUT operated. The effects, if any, from frequency sweeping, frequency hopping, other modulation techniques and frequency stability over expected variations in temperature and supply voltage were considered.

1.2 Statement of Compliance

The equipment under test is found to be complying with the following standards:

FCC Part 15, October 1, 2016 Edition
RSS-210 Issue 9, August 2016
RSS-Gen Issue 4, November 2014

TEST REPORT

2.0 GENERAL DESCRIPTION

2.1 Product Description

The D785 is a VoIP Phone. The Equipment Under Test (EUT) is an VoIP phone which can support Bluetooth 3.0 and 4.0. For Bluetooth 3.0, it operates at the frequency range of 2402-2480MHz with 1 MHz channel spacing. For Bluetooth 4.0, it operates at the frequency range of 2402-2480MHz with 2 MHz channel spacing. The EUT is powered by 100-240VAC adaptor or PoE.

The Bluetooth antenna used in base unit is integral, and the test sample is a prototype.

For both FCC & IC, the Model(s): ET685 and X885 are the same as the Model: D785 in electronics/electrical designs including software & firmware, PCB layout and construction design/physical design/enclosure. The only differences between these models are model number and brand name to be sold for marketing purpose.

The circuit description is saved with filename: descri.pdf.

2.2 Test Methodology

Both AC power line-conducted and radiated emission measurements were performed according to the procedures in ANSI C63.10 (2013). Preliminary radiated scans and all radiated measurements were performed in Radiated Emission Test Sites. All Radiated tests were performed at an antenna to EUT distance of 3 meters, unless stated otherwise in the "**Justification Section**" of this Application.

2.3 Test Facility

The radiated emission test sites and conducted measurement facility used to collect the radiated data and conducted data are at Workshop No. 3, G/F., World-Wide Industrial Centre, 43-47 Shan Mei Street, Fo Tan, Sha Tin, N.T., Hong Kong. This test facility and site measurement data have been fully placed on file with the FCC and IC No. 2042V.

TEST REPORT

3.0 SYSTEM TEST CONFIGURATION

3.1 Justification

For radiated emissions testing, the equipment under test (EUT) was setup to transmit continuously mode to simplify the measurement methodology. Care was taken to ensure proper power supply voltages during testing. During testing, all cables (if any) were manipulated to produce worst case emissions.

The EUT was powered by 100-240VAC adaptor or PoE.

For the measurements, the EUT was attached to a plastic stand if necessary and placed on the wooden turntable which is four feet in diameter and approximately 0.8m in height above the ground plane for emission measurement at or below 1GHz and 1.5m in height above the ground plane for emission measurement above 1GHz. If the base unit attached to peripherals, they were connected and operational to simulate typical use. Else, the base was wired to transmit full power.

The signal was maximized through rotation and placement in the three orthogonal axes. The antenna height and polarization were varied during the search for maximum signal level. The antenna height was varied from 1 to 4 meters. Radiated emissions were taken at three meters unless the signal level was too low for measurement at that distance. If necessary, a pre-amplifier was used and/or the test was conducted at a closer distance.

For any intentional radiator powered by AC power line, measurements of the radiated signal level of the fundamental frequency component of the emission was performed with the supply voltage varied between 85% and 115% of the nominal rated supply voltage.

For transmitter radiated measurement, the spectrum analyzer resolution bandwidth was 100 kHz for frequencies below 1000 MHz. The resolution bandwidth was 3 MHz for frequencies above 1000 MHz.

Radiated emission measurement for transmitter was performed from the lowest radio frequency signal generated in the device which is greater than 9 kHz to the tenth harmonic of the highest fundamental frequency or to 40 GHz, whichever is lower.

Emission that are directly caused by digital circuits in the transmit path and transmitter portion were measured, and the limit are according to FCC Part 15 Section 15.209. Digital circuitry used to control additional functions other than the operation of the transmitter are subject to FCC Part 15 Section 15.109 Limits.

TEST REPORT

3.1 Justification - Cont'd

Detector function for radiated emissions is in peak mode. Average readings, when required, are taken by measuring the duty cycle of the equipment under test and subtracting the corresponding amount in dB from the measured peak readings. A detailed description for the calculation of the average factor can be found in section 4.2.3.

Determination of pulse desensitization was made according to *Hewlett Packard Application Note 150-2, Spectrum Analysis... Pulsed RF*. The effective period (T_{eff}) was $625\mu s$. With the resolution bandwidth 1MHz and spectrum analyzer IF bandwidth 3dB, the pulse desensitization factor was 0dB.

For AC line conducted emission test, the EUT along with its peripherals were placed on a 1.0m(W)x1.5m(L) and 0.8m in height wooden table and the EUT was adjusted to maintain a 0.4 meter space from a vertical reference plane. The EUT was connected to power mains through a line impedance stabilization network (LISN), which provided 50ohm coupling impedance for measuring instrument. The LISN housing, measuring instrument case, reference ground plane, and vertical ground plane were bounded together. The excess power cable between the EUT and the LISN was bundled.

All connecting cables of EUT and peripherals were manipulated to find the maximum emission.

All relevant operation modes and power sources have been tested, and the worst case data was included in this report.

3.2 EUT Exercising Software

The EUT exercise program used during radiated and conducted testing was designed to exercise the various system components in a manner similar to a typical use.

TEST REPORT

3.3 Radiated Emission Test Setup

The figure below shows the test setup, which is utilized to make these measurements.

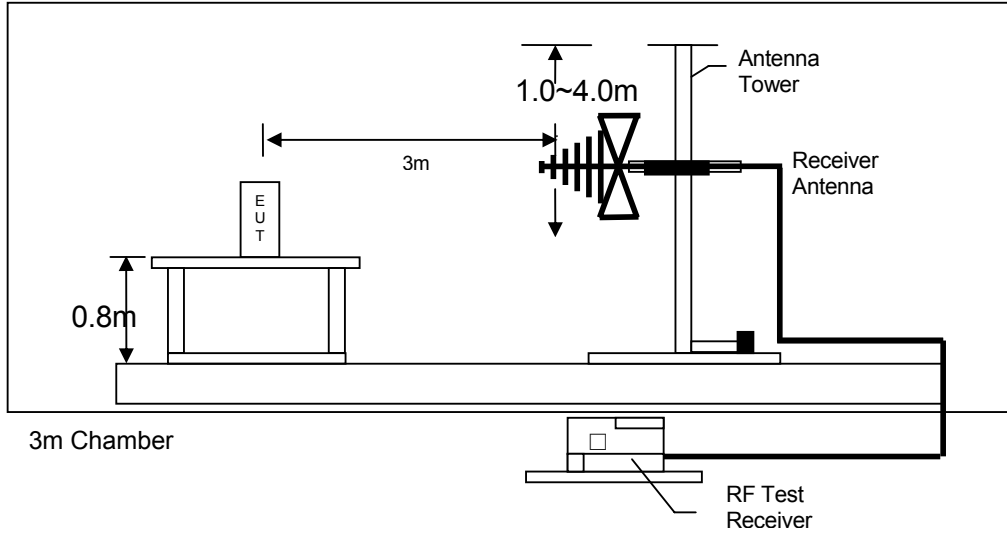

Figure 3.3.1 Test setup of radiated emissions up to 1GHz

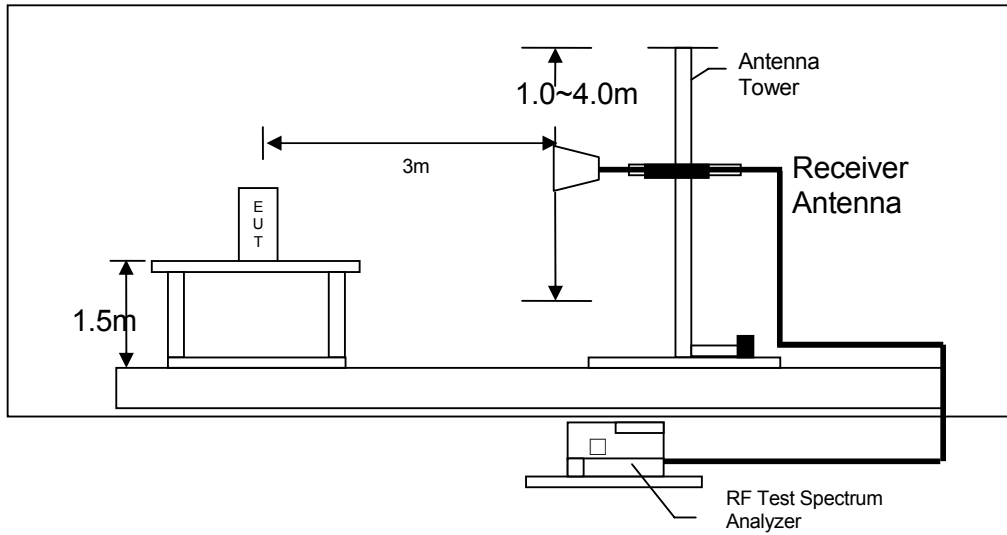

Figure 3.3.2 Test setup of radiated emissions above 1GHz

TEST REPORT

3.4 Conducted Emission Test Setup

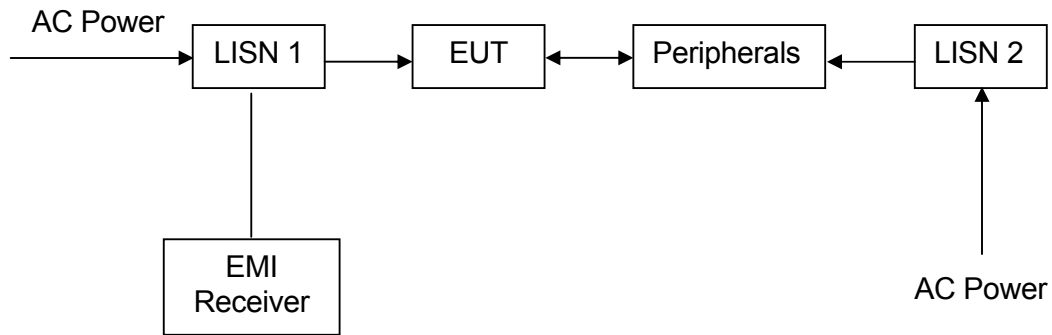

Figure 3.4.1

TEST REPORT

3.5 Details of EUT and Description of Accessories

Details of EUT:

An AC adaptor (provided with the unit) was used to power the device. Their description are listed below.

- (1) An AC adaptor with ferrite (Brand: SIL, Input: 100-240V, 50/60Hz, 300mA to Output: 5V, 2000mA, Model: SSA-050200US) (Supplied by Client)
- (2) An AC adaptor (Brand: PHIHONG, Input: 100-240V, 50/60Hz, 300mA to Output: 5V, 2000mA, Model: PSM10R-050) (Supplied by Client)
- (3) An AC adaptor (Brand: TenPao, Input: 100-240V, 50/60Hz, 500mA to Output: 5V, 2000mA, Model: S018BAM0500200) (Supplied by Client)

Description of Accessories:

- (1) Expansion Module (Brand: Snom, Model: D7, PN: 00004011) (Supplied by Client)
- (2) Notebook (Brand: HP) (Supplied by Intertek)
- (3) 2.0m long LAN Cable x2 with ferrite (Supplied by Client)
- (4) Headset (Brand: Snom, Model: A100M, PN: 00004341) (Supplied by Client)
- (5) EHS Advanced V2.0 (Brand: snom, Model: EHS Advanced V2.0, PN: 00002362) (Supplied by Client)
- (6) PoE (Power over Ethernet), Brand: TP-LINK, Model: TL-POE150S with Adaptor (Model: MU24-1480050-B2, Input: 100-240V, 50/60Hz, 1.0A; Output: 48V, 0.5A) (Supplied by Intertek)

3.6 Measurement Uncertainty

When determining of the test conclusion, the Measurement Uncertainty of test has been considered. The values of the Measurement uncertainty for radiated emission test, AC line conducted emission test and RF conducted test, frequency stability and timing jitter are $\pm 5.3\text{dB}$, $\pm 4.2\text{dB}$, $\pm 1\text{dB}$, $\pm 23\text{Hz}$, $0.1\mu\text{s}$ respectively.

Uncertainty and Compliance - Unless the standard specifically states that measured values are to be extended by the measurement uncertainty in determining compliance, all compliance determinations are based on the actual measured value.

TEST REPORT

4.0 TEST RESULTS

Data is included of the worst case configuration (the configuration which resulted in the highest emission levels). A sample calculation, configuration photographs and data tables of the emissions are included.

4.1 Field Strength Calculation

The field strength is calculated by adding the reading on the Spectrum Analyzer to the factors associated with preamplifiers (if any), antennas, cables, pulse desensitization and average factors (when specified limit is in average and measurements are made with peak detectors). A sample calculation is included below.

$$FS = RA + AF + CF - AG + PD + AV$$

where

- FS = Field Strength in dB μ V/m
- RA = Receiver Amplitude (including preamplifier) in dB μ V
- CF = Cable Attenuation Factor in dB
- AF = Antenna Factor in dB
- AG = Amplifier Gain in dB
- PD = Pulse Desensitization in dB
- AV = Average Factor in -dB

In the radiated emission table which follows, the reading shown on the data table may reflect the preamplifier gain. An example of the calculations, where the reading does not reflect the preamplifier gain, follows:

$$FS = RA + AF + CF - AG + PD + AV$$

Example

Assume a receiver reading of 62.0 dB μ V is obtained. The antenna factor of 7.4 dB and cable factor of 1.6 dB is added. The amplifier gain of 29 dB is subtracted. The pulse desensitization factor of the spectrum analyzer was 0 dB, and the resultant average factor was -10 dB. The net field strength for comparison to the appropriate emission limit is 32 dB μ V/m. This value in dB μ V/m was converted to its corresponding level in μ V/m.

$$RA = 62.0 \text{ dB}\mu\text{V}$$

$$AF = 7.4 \text{ dB}$$

$$CF = 1.6 \text{ dB}$$

$$AG = 29 \text{ dB}$$

$$PD = 0 \text{ dB}$$

$$AV = -10 \text{ dB}$$

$$FS = 62 + 7.4 + 1.6 - 29 + 0 + (-10) = 32 \text{ dB}\mu\text{V/m}$$

$$\text{Level in } \mu\text{V/m} = \text{Common Antilogarithm } [(32 \text{ dB}\mu\text{V/m})/20] = 39.8 \mu\text{V/m}$$

TEST REPORT

4.2 Radiated Emissions

4.2.1 Radiated Emission Configuration Photograph

Worst Case Radiated Emission (powered by PoE)
at

333.286 MHz

The worst case radiated emission configuration photographs are saved with filename: config photos.pdf

4.2.2 Radiated Emission Data

The data in tables 1-4 list the significant emission frequencies, the limit and the margin of compliance. Test setup is shown in section 3.3 Figure 3.3.1 and 3.3.2.

Judgement -

Passed by 0.9 dB margin

TEST REPORT

RADIATED EMISSION DATA

Mode: TX-Channel 00

Table 1

Polarization	Frequency (MHz)	Reading (dB μ V)	Pre-Amp Gain (dB)	Antenna Factor (dB)	Net at 3m - Peak (dB μ V/m)	Average Factor (dB)	Calculated at 3m (dB μ V/m)	Average Limit at 3m (dB μ V/m)	Margin (dB)
H	2402.000	100.1	33	29.4	96.5	41.5	55.0	94.0	-39.0
H	4804.000	42.3	33	34.9	44.2	41.5	2.7	54.0	-51.3
V	7206.000	43.6	33	37.9	48.5	41.5	7.0	54.0	-47.0
V	9608.000	41.5	33	40.4	48.9	41.5	7.4	54.0	-46.6
V	12010.000	45.9	33	40.5	53.4	41.5	11.9	54.0	-42.1
V	14412.000	49.1	33	40.0	56.1	41.5	14.6	54.0	-39.4

Polarization	Frequency (MHz)	Reading (dB μ V)	Pre-Amp Gain (dB)	Antenna Factor (dB)	Net at 3m - Peak (dB μ V/m)	Peak Limit at 3m (dB μ V/m)	Margin (dB)
H	2402.000	100.1	33	29.4	96.5	114.0	-17.5
H	4804.000	42.3	33	34.9	44.2	74.0	-29.8
V	7206.000	43.6	33	37.9	48.5	74.0	-25.5
V	9608.000	41.5	33	40.4	48.9	74.0	-25.1
V	12010.000	45.9	33	40.5	53.4	74.0	-20.6
V	14412.000	49.1	33	40.0	56.1	74.0	-17.9

- NOTES:
1. Peak detector is used for the emission measurement.
 2. All measurements were made at 3 meters. Radiated emissions not detected at the 3-meter distance were measured at 0.3-meter and an inverse proportional extrapolation was performed to compare the signal level to the 3-meter limit. No other radiated emissions than those reported were detected at a test distance of 0.3-meter.
 3. Negative value in the margin column shows emission below limit.
 4. Horn antenna is used for the emission over 1000MHz.
 5. Emission within the restricted band meets the requirement of FCC Part 15 Section 15.205 / RSS-210 Section 4.1.

TEST REPORT

Mode: TX-Channel 39

Table 2

Polarization	Frequency (MHz)	Reading (dB μ V)	Pre-Amp Gain (dB)	Antenna Factor (dB)	Net at 3m - Peak (dB μ V/m)	Average Factor (dB)	Calculated at 3m (dB μ V/m)	Average Limit at 3m (dB μ V/m)	Margin (dB)
H	2440.000	99.4	33	29.4	95.8	41.5	54.3	94.0	-39.7
H	4880.000	42.8	33	34.9	44.7	41.5	3.2	54.0	-50.8
V	7320.000	43.4	33	37.9	48.3	41.5	6.8	54.0	-47.2
V	9760.000	40.8	33	40.4	48.2	41.5	6.7	54.0	-47.3
V	12200.000	45.6	33	40.5	53.1	41.5	11.6	54.0	-42.4
V	14640.000	51.2	33	38.4	56.6	41.5	15.1	54.0	-38.9

Polarization	Frequency (MHz)	Reading (dB μ V)	Pre-Amp Gain (dB)	Antenna Factor (dB)	Net at 3m - Peak (dB μ V/m)	Peak Limit at 3m (dB μ V/m)	Margin (dB)
H	2440.000	99.4	33	29.4	95.8	114.0	-18.2
H	4880.000	42.8	33	34.9	44.7	74.0	-29.3
V	7320.000	43.4	33	37.9	48.3	74.0	-25.7
V	9760.000	40.8	33	40.4	48.2	74.0	-25.8
V	12200.000	45.6	33	40.5	53.1	74.0	-20.9
V	14640.000	51.2	33	38.4	56.6	74.0	-17.4

- NOTES:
1. Peak detector is used for the emission measurement.
 2. All measurements were made at 3 meters. Radiated emissions not detected at the 3-meter distance were measured at 0.3-meter and an inverse proportional extrapolation was performed to compare the signal level to the 3-meter limit. No other radiated emissions than those reported were detected at a test distance of 0.3-meter.
 3. Negative value in the margin column shows emission below limit.
 4. Horn antenna is used for the emission over 1000MHz.
 5. Emission within the restricted band meets the requirement of FCC Part 15 Section 15.205 / RSS-210 Section 4.1.

TEST REPORT

Mode: TX-Channel 78

Table 3

Polarization	Frequency (MHz)	Reading (dB μ V)	Pre-Amp Gain (dB)	Antenna Factor (dB)	Net at 3m - Peak (dB μ V/m)	Average Factor (dB)	Calculated at 3m (dB μ V/m)	Average Limit at 3m (dB μ V/m)	Margin (dB)
H	2480.000	98.2	33	29.4	94.6	41.5	53.1	94.0	-40.9
H	4960.000	42.9	33	34.9	44.8	41.5	3.3	54.0	-50.7
V	7440.000	43.8	33	37.9	48.7	41.5	7.2	54.0	-46.8
V	9920.000	40.9	33	40.4	48.3	41.5	6.8	54.0	-47.2
V	12400.000	46.3	33	40.5	53.8	41.5	12.3	54.0	-41.7
V	14880.000	51.0	33	38.4	56.4	41.5	14.9	54.0	-39.1

Polarization	Frequency (MHz)	Reading (dB μ V)	Pre-Amp Gain (dB)	Antenna Factor (dB)	Net at 3m - Peak (dB μ V/m)	Peak Limit at 3m (dB μ V/m)	Margin (dB)
H	2480.000	98.2	33	29.4	94.6	114.0	-19.4
H	4960.000	42.9	33	34.9	44.8	74.0	-29.2
V	7440.000	43.8	33	37.9	48.7	74.0	-25.3
V	9920.000	40.9	33	40.4	48.3	74.0	-25.7
V	12400.000	46.3	33	40.5	53.8	74.0	-20.2
V	14880.000	51.0	33	38.4	56.4	74.0	-17.6

- NOTES:
1. Peak detector is used for the emission measurement.
 2. All measurements were made at 3 meters. Radiated emissions not detected at the 3-meter distance were measured at 0.3-meter and an inverse proportional extrapolation was performed to compare the signal level to the 3-meter limit. No other radiated emissions than those reported were detected at a test distance of 0.3-meter.
 3. Negative value in the margin column shows emission below limit.
 4. Horn antenna is used for the emission over 1000MHz.
 5. Emission within the restricted band meets the requirement of FCC Part 15 Section 15.205 / RSS-210 Section 4.1.

TEST REPORT

Mode: Bluetooth headset online

Table 4

Polarization	Frequency (MHz)	Reading (dB μ V)	Pre-amp (dB)	Antenna Factor (dB)	Net at 3m (dB μ V/m)	Limit at 3m (dB μ V/m)	Margin (dB)
V	34.580	42.1	16	10.0	36.1	40.0	-3.9
V	39.430	42.4	16	10.0	36.4	40.0	-3.6
V	42.340	43.4	16	10.0	37.4	40.0	-2.6
V	42.879	43.7	16	10.0	37.7	40.0	-2.3
V	43.741	44.4	16	10.0	38.4	40.0	-1.6
V	44.550	43.1	16	10.0	37.1	40.0	-2.9
V	51.286	43.4	16	11.0	38.4	40.0	-1.6
H	96.283	39.3	16	12.0	35.3	43.5	-8.2
H	119.994	38.4	16	14.0	36.4	43.5	-7.1
V	154.914	39.1	16	15.0	38.1	43.5	-5.4
H	242.753	32.3	16	19.0	35.3	46.0	-10.7
H	333.286	37.1	16	24.0	45.1	46.0	-0.9
V	413.257	32.5	16	25.0	41.5	46.0	-4.5
V	479.595	31.7	16	26.0	41.7	46.0	-4.3
V	909.897	24.8	16	32.0	40.8	46.0	-5.2
H	959.960	26.7	16	33.0	43.7	46.0	-2.3
V	1000.000	27.1	16	33.0	44.1	54.0	-9.9

- NOTES:
1. Peak Detector Data is used for the emission measurement.
 2. All measurements were made at 3 meters. Harmonic emissions not detected at the 3-meter distances were measured at 0.3-meter and an inverse proportional extrapolation was performed to compare the signal level to the 3-meter limit. No other harmonic emissions than those reported were detected at a test distance of 0.3-meter.
 3. Negative sign in the column shows value below limit.
 4. Horn antenna is used for the emission over 1000MHz.
 5. Emission within the restricted band meets the requirement of FCC Part 15 Section 15.205 / RSS-210 Section 4.1.

TEST REPORT

4.2.3 Transmitter Duty Cycle Calculation

The duty cycle is simply the on-time divided by the period:

The duration of one cycle = 100 ms

Effective period of the cycle = $10 \times 0.084 = 0.84$ ms

DC = $0.84 / 100 = 0.0084$

Therefore, the averaging factor is found by $20 \log 0.0084 = -41.5$ dB.

TEST REPORT

AVERAGE FACTOR (Bluetooth 4.0 BLE)

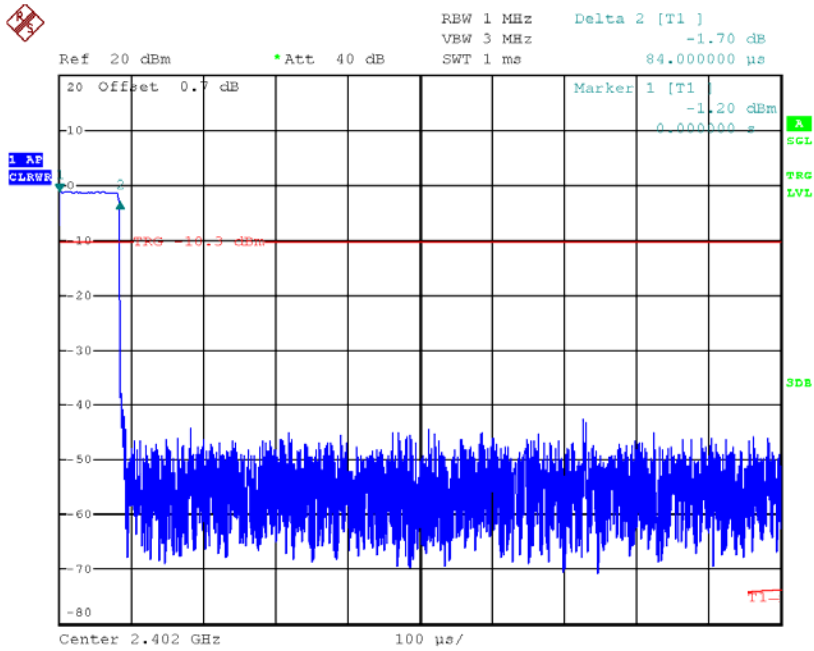
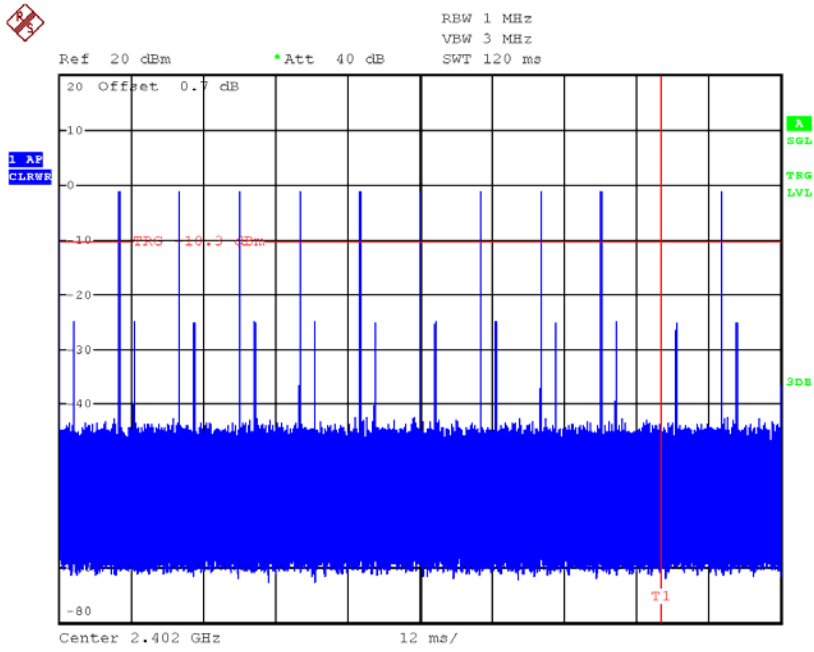

TEST REPORT

4.3 Radiated Emission on the Bandedge

From the following plots, they show that the fundamental emissions are confined in the specified band (2400MHz and 2483.5MHz). In case of emissions up to two standard bandwidths away from the bandedge, the delta measurement technique is used for determining bandedge compliance. Standard bandwidth is the bandwidth specified by ANSI C63.10 (2013) for frequency being measured.

Emissions radiated outside of the specified frequency bands, except harmonics, are attenuated by 50 dB below the level of the fundamental or to the general radiated emission limits in FCC Part 15 Section 15.209 / RSS-210 4.4, whichever is the lesser attenuation, which meet the requirement of FCC Part 15 Section 15.249(d) /RSS-210 B.10.

The plots of radiated emission on the bandedge are saved as below.

TEST REPORT

LOWEST CHANNEL

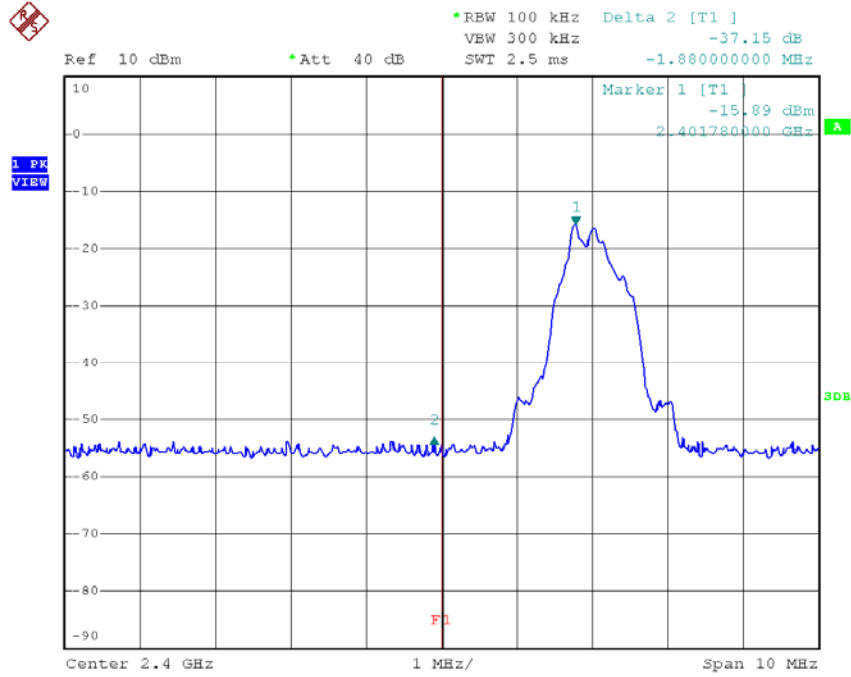

HIGHEST CHANNEL

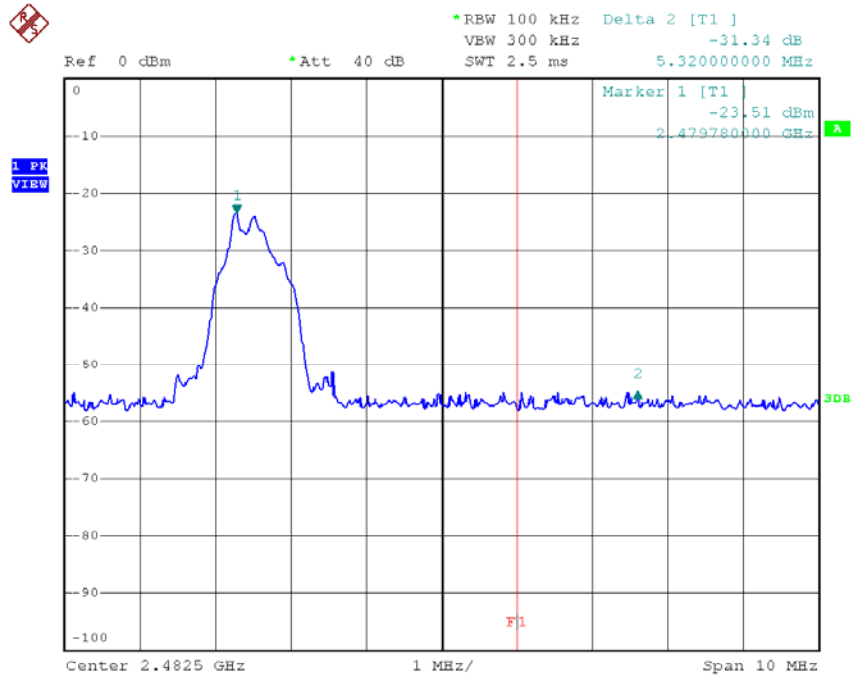

TEST REPORT

PEAK MEASUREMENT (Bluetooth 4.0 BLE)

Bandedge compliance is determined by applying marker-delta method, i.e. (Bandedge Plot).

Lower bandedge

Peak Resultant field strength = Fundamental emissions (peak value) – delta from the plot

$$=96.5 \text{ dB}\mu\text{V/m} - 37.2 \text{ dB}$$

$$=59.3 \text{ dB}\mu\text{V/m}$$

Average Resultant field strength = Fundamental emissions (average value) – delta from the plot

$$=55.0 \text{ dB}\mu\text{V/m} - 37.2 \text{ dB}$$

$$=17.8 \text{ dB}\mu\text{V/m}$$

Upper bandedge

Peak Resultant field strength = Fundamental emissions (peak value) – delta from the plot

$$=94.6 \text{ dB}\mu\text{V/m} - 31.3 \text{ dB}$$

$$=63.3 \text{ dB}\mu\text{V/m}$$

Average Resultant field strength = Fundamental emissions (average value) – delta from the plot

$$=53.1 \text{ dB}\mu\text{V/m} - 31.3 \text{ dB}$$

$$=21.8 \text{ dB}\mu\text{V/m}$$

The resultant field strength meets the general radiated emission limit in Section 15.209 / RSS-210 4.4, which does not exceed 74 dB μ V/m (Peak Limit) and 54 dB μ V/m (Average Limit).

TEST REPORT

4.4 AC Power Line Conducted Emission

- [] Not applicable – EUT is only powered by battery for operation.
- [x] EUT connects to AC power line. Emission Data is listed in following pages.
- [] Base Unit connects to AC power line and has transmission. Handset connects to AC power line but has no transmission. Emission Data of Base Unit is listed in following pages.

Test setup is shown in section 3.4 Figure 3.4.1.

4.4.1 AC Power Line Conducted Emission Configuration Photograph

Worst Case Line-Conducted Configuration (Powered by Tenpao adaptor)
at

321 kHz

The worst case line conducted configuration photographs are saved with filename: config photos.pdf.

4.4.2 AC Power Line Conducted Emission Data

The plot(s) and data in the following pages list the significant emission frequencies, the limit and the margin of compliance.

Passed by 6.48 dB margin compared with CISPR average limit

TEST REPORT

CONDUCTED EMISSION DATA

Worst Case: Bluetooth On

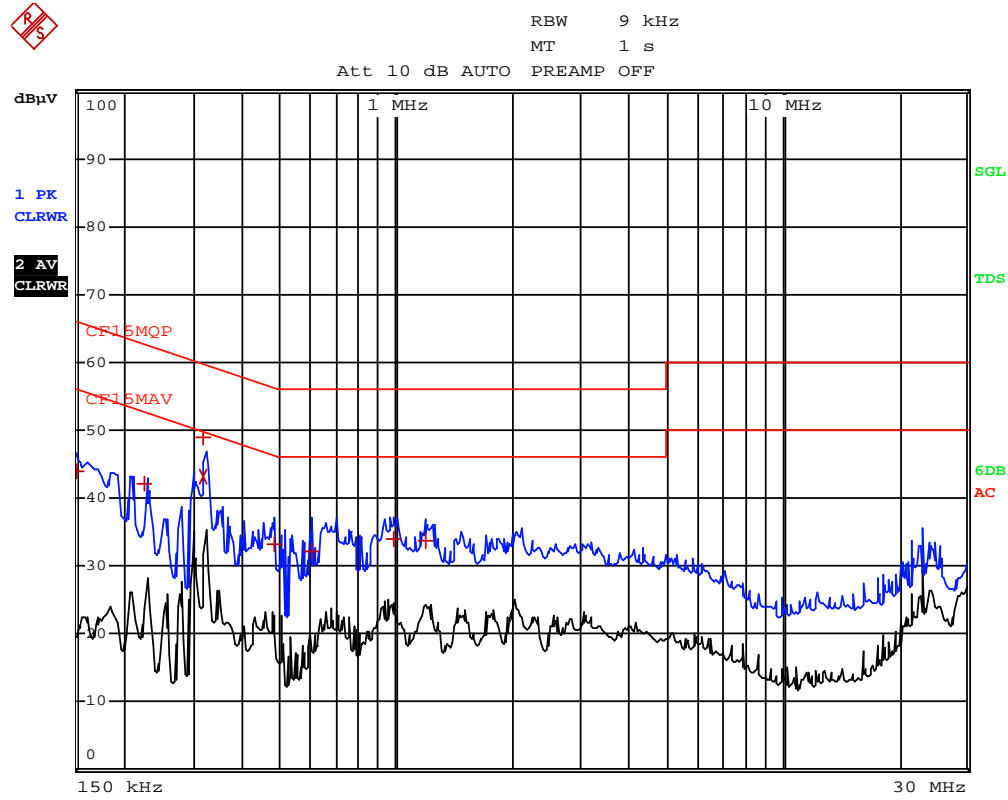

TEST REPORT

Worst Case: Bluetooth On

EDIT PEAK LIST (Final Measurement Results)				
Trace1:	CF15MQP			
Trace2:	CF15MAV			
Trace3:	---			
TRACE	FREQUENCY	LEVEL dBµV		DELTA LIMIT dB
1 Quasi Peak	150 kHz	43.98	N gnd	-22.01
1 Quasi Peak	226.5 kHz	42.04	N gnd	-20.53
1 Quasi Peak	321 kHz	48.98	N gnd	-10.69
2 CISPR Average	321 kHz	43.19	N gnd	-6.48
1 Quasi Peak	483 kHz	33.11	N gnd	-23.17
1 Quasi Peak	604.5 kHz	32.15	N gnd	-23.84
1 Quasi Peak	982.5 kHz	34.03	N gnd	-21.96
1 Quasi Peak	1.1895 MHz	33.80	N gnd	-22.19

TEST REPORT

4.5 Occupied Bandwidth

Occupied Bandwidth Results: (Bluetooth 4.0 BLE)

Bluetooth (MHz)	Occupied Bandwidth (kHz)
Low Channel: 2402	1.05
Middle Channel: 2442	1.08
High Channel: 2480	1.14

The worst case is shown as below

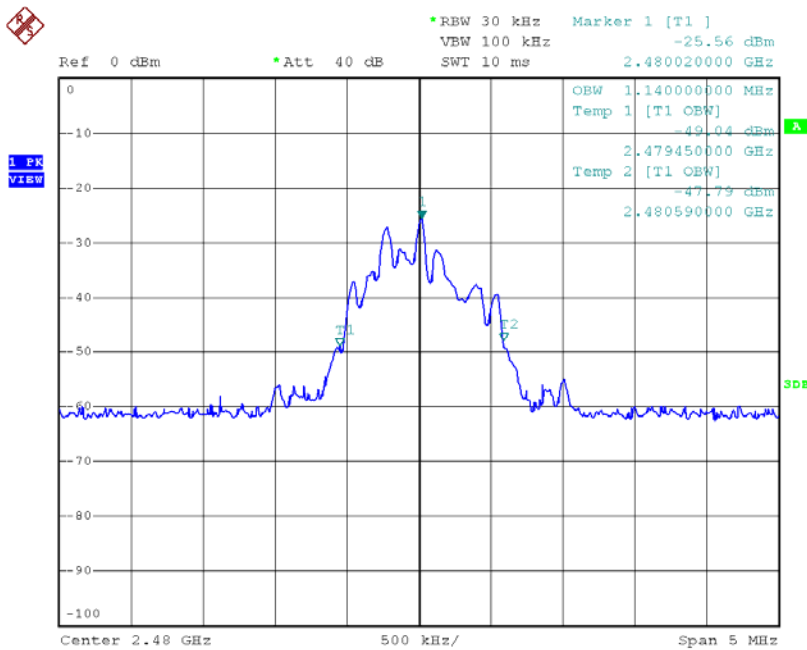

TEST REPORT

5.0 EQUIPMENT LIST

1) Radiated Emissions Test

Equipment	EMI Test Receiver	Spectrum Analyzer	BiConiLog Antenna
Registration No.	EW-3156	EW-2253	EW-3061
Manufacturer	ROHDESCHWARZ	ROHDESCHWARZ	EMCO
Model No.	ESR26	FSP40	3142E
Calibration Date	November 10, 2017	July 24, 2017	November 02, 2017
Calibration Due Date	November 10, 2018	July 24, 2018	November 02, 2018

Equipment	Active Loop H-field (9kHz to 30MHz)	Double Ridged Guide Antenna	Pyramidal Horn Antenna
Registration No.	EW-2313	EW-1133	EW-0905
Manufacturer	ELECTROMETRI	EMCO	EMCO
Model No.	EM-6876	3115	3160-09
Calibration Date	May 18, 2016	May 24, 2017	August 18, 2017
Calibration Due Date	November 18, 2017	November 24, 2018	February 18, 2019

Equipment	RF Cable 9kHz to 1000MHz	RF Cable (up to 40GHz)	Notch Filter (cutoff frequency 2.4GHz to 2.5GHz)
Registration No.	EW-3170	EW-3155	EW-3155
Manufacturer	N/A	N/A	MICROTRONICS
Model No.	9kHz to 1000MHz	1-40 GHz	BRM50701-02
Calibration Date	March 20, 2017	January 29, 2018	May 26, 2017
Calibration Due Date	March 20, 2018	January 29, 2019	May 26, 2018

2) Conducted Emissions Test

Equipment	EMI Test Receiver	LISN	Pulse Limiter
Registration No.	EW-2500	EW-0192	EW-0700
Manufacturer	R&S	R&S	ROHDESCHWARZ
Model No.	ESCI	ESH3-Z5	ESH3-Z2
Calibration Date	October 13, 2017	October 27, 2017	September 07, 2017
Calibration Due Date	October 13, 2018	August 25, 2018	March 07, 2019

Equipment	RF Cable
Registration No.	EW-2451
Manufacturer	RADIALL
Model No.	bnc m st / 142 / bnc m st 80cm
Calibration Date	August 08, 2017
Calibration Due Date	August 08, 2018

3) Bandedge Measurement Test

Equipment	Spectrum Analyzer
Registration No.	EW-2329
Manufacturer	R&S
Model No.	FSP3
Calibration Date	September 28, 2017
Calibration Due Date	September 28, 2018

END OF TEST REPORT