

# SIP CONTEMPORARY SERIES

CTM-S2115

SIP 1-Line Hidden Base with Cordless Handset and Charger

DRAFT

**vtech**<sup>®</sup>

Quick Start Guide

## Important Safety Instructions

When using your telephone equipment, basic safety precautions should always be followed to reduce the risk of fire, electric shock and injury, including the following:

1. This product should be installed by a qualified technician.
2. This product should only be connected to the host equipment and never directly to the network such as Public Switch Telephone Network (PSTN) or Plain Old Telephone Services (POTS).
3. Read and understand all instructions.
4. Follow all warnings and instructions marked on the product.
5. Unplug this product from the wall outlet before cleaning. Do not use liquid or aerosol cleaners. Use a damp cloth for cleaning.
6. Do not use this product near water such as near a bath tub, wash bowl, kitchen sink, laundry tub or swimming pool, or in a wet basement or shower.
7. Do not place this product on an unstable table, shelf, stand or other unstable surfaces.
8. Slots and openings in the back or bottom of the telephone base and handset are provided for ventilation. To protect them from overheating, these openings must not be blocked by placing the product on a soft surface such as a bed, sofa or rug. This product should never be placed near or over a radiator or heat register. This product should not be placed in any area where proper ventilation is not provided.
9. This product should be operated only from the type of power source indicated on the marking label. If you are not sure of the type of power supplied at the premises, consult your dealer or local power company.
10. Do not allow anything to rest on the power cord. Do not install this product where the cord may be walked on.
11. Never push objects of any kind into this product through the slots in the telephone base or handset because they may touch dangerous voltage points or create a short circuit. Never spill liquid of any kind on the product.
12. To reduce the risk of electric shock, do not disassemble this product, but take it to an authorized service facility. Opening or removing parts of the base station or handset other than specified access doors may expose you to dangerous voltages or other risks. Incorrect reassembling can cause electric shock when the product is subsequently used.
13. Do not overload wall outlets and extension cords.

14. Unplug this product from the wall outlet and refer servicing to an authorized service facility under the following conditions:
  - When the power supply cord or plug is damaged or frayed.
  - If liquid has been spilled onto the product.
  - If the product has been exposed to rain or water.
  - If the product does not operate normally by following the operating instructions. Adjust only those controls that are covered by the operation instructions. Improper adjustment of other controls may result in damage and often requires extensive work by an authorized technician to restore the product to normal operation.
  - If the product has been dropped and the telephone base and/or handset has been damaged.
  - If the product exhibits a distinct change in performance.
15. Avoid using a telephone (other than cordless) during an electrical storm. There is a remote risk of electric shock from lightning.
16. Do not use the telephone to report a gas leak in the vicinity of the leak. Under certain circumstances, a spark may be created when the adapter is plugged into the power outlet, or when the handset is replaced in its cradle. This is a common event associated with the closing of any electrical circuit. The user should not plug the phone into a power outlet, and should not put a charged handset into the cradle, if the phone is located in an environment containing concentrations of flammable or flame-supporting gases, unless there is adequate ventilation. A spark in such an environment could create a fire or explosion. Such environments might include: medical use of oxygen without adequate ventilation; industrial gases (cleaning solvents; gasoline vapors; etc.); a leak of natural gas; etc.
17. Only put the handset of your telephone next to your ear when it is in normal talk mode.
18. The power adapters are intended to be correctly oriented in a vertical or floor mount position. The prongs are not designed to hold the plug in place if it is plugged into a ceiling, under-the-table or cabinet outlet.
19. Use only the power cord and batteries indicated in this manual. Do not dispose of batteries in a fire. They may explode. Check with local codes for possible special disposal instructions.
20. In wall mounting position, make sure to mount the telephone base on the wall by aligning the eyelets with the mounting studs of the wall plate. Then slide the telephone base down on both mounting studs until it locks into

place. Refer to the full instructions in Installation in the user's manual.

21. Listed PoE (The product is considered not likely to require connection to an Ethernet network with outside plant routing).



- Keep small metallic objects such as pins and staples away from the handset receiver.
- There may be a risk of explosion if a wrong type of handset battery is used (CTM-S2115). Use only the supplied rechargeable battery (BT164392/BT264392) or replacement battery (BT264392). Dispose of used batteries according to the information in The RBRC® seal in this user guide.

## SAVE THESE INSTRUCTIONS

### Instructions de sécurité importantes

Lorsque vous utilisez votre équipement téléphonique, des précautions de base doivent toujours être prises pour réduire les risques d'incendie, d'électrocution et de blessure, notamment les suivantes :

1. Ce produit doit être installé par un technicien qualifié.
2. Ce produit ne doit être connecté qu'à l'équipement hôte et jamais directement au réseau tel que le réseau téléphonique public commuté (RTPC) ou les services téléphoniques classiques (POTS).
3. Lire et comprendre toutes les instructions.
4. Respecter tous les avertissements et instructions figurant sur le produit.
5. Débranchez ce produit de la prise murale avant de le nettoyer. N'utilisez pas de nettoyants liquides ou en aérosol. Utilisez un chiffon humide pour le nettoyage.
6. N'utilisez pas ce produit près de l'eau, par exemple près d'une baignoire, d'une cuvette de lavage, d'un évier de cuisine, d'une cuve de lavage ou d'une piscine, ou dans un sous-sol ou une douche humide.
7. Ne pas placer ce produit sur une table, une étagère, un support ou toute autre surface instable.
8. Des fentes et des ouvertures à l'arrière ou en-dessous du socle du téléphone et du combiné sont prévues pour la ventilation. Afin de les protéger contre la surchauffe, ces ouvertures ne doivent pas être obstruées en plaçant le produit sur une surface souple comme un lit, un divan ou un tapis. Ce produit ne doit jamais être placé à proximité ou au-dessus d'un radiateur ou d'un registre de chaleur. Ce produit ne doit pas être placé dans un endroit où une ventilation adéquate n'est pas assurée.

9. Ce produit ne doit être utilisé qu'avec le type de source d'énergie indiqué sur l'étiquette de marquage. Si vous n'êtes pas sûr du type d'alimentation électrique sur place, consultez votre revendeur ou votre compagnie d'électricité locale.
10. Ne laissez rien reposer sur le cordon d'alimentation. N'installez pas ce produit à un endroit où l'on pourrait marcher sur le cordon.
11. N'introduisez jamais d'objets de quelque nature que ce soit dans ce produit par les fentes du socle du téléphone ou du combiné, car ils pourraient toucher des points de tension dangereux ou créer un court-circuit. Ne jamais renverser de liquide de quelque nature que ce soit sur le produit.
12. Pour réduire le risque d'électrocution, ne démontez pas ce produit, mais confiez-le à un service après-vente agréé. Ouvrir ou retirer des parties du socle du téléphone ou du combiné autres que les portes d'accès spécifiées peut vous exposer à des tensions dangereuses ou à d'autres risques. Un remontage incorrect peut provoquer une électrocution lors de l'utilisation ultérieure du produit.
13. Ne surchargez pas les prises murales et les rallonges électriques.
14. Débranchez ce produit de la prise murale et confiez l'entretien à un centre de service agréé dans les conditions suivantes :
  - Lorsque le cordon d'alimentation ou la fiche est endommagé ou effiloché.
  - Si du liquide a été renversé sur le produit.
  - Si le produit a été exposé à la pluie ou à l'eau.
  - Si le produit ne fonctionne pas normalement en suivant les instructions d'utilisation. Ne réglez que les commandes qui sont couvertes par le mode d'emploi. Un mauvais réglage des autres commandes peut entraîner des dommages et nécessite souvent un travail important de la part d'un technicien autorisé pour remettre le produit en état de fonctionnement.
  - Si le produit est tombé et que le socle du téléphone et/ou le combiné ont été endommagés.
  - Si le produit présente un changement distinct de performance.
15. Évitez d'utiliser un téléphone (autre que sans fil) pendant un orage électrique. Il existe un risque d'électrocution dû à la foudre.
16. N'utilisez pas le téléphone pour signaler une fuite de gaz à proximité de la fuite. Dans certaines circonstances, une étincelle peut se produire lorsque l'adaptateur est branché dans la prise de courant, ou lorsque le combiné est replacé dans son berceau. Il s'agit d'un événement courant associé à la fermeture de tout circuit électrique. L'utilisateur ne doit pas brancher le téléphone dans une prise de courant, ni placer un combiné chargé dans son socle, si le téléphone est situé dans

un environnement contenant des concentrations de gaz inflammables ou propices aux flammes, à moins qu'il n'y ait une ventilation adéquate. Une étincelle dans un tel environnement pourrait créer un incendie ou une explosion. Ces environnements peuvent comprendre : l'utilisation médicale de l'oxygène sans ventilation adéquate; les gaz industriels (solvants de nettoyage; vapeurs d'essence; etc.); une fuite de gaz naturel; etc.

17. Ne placez le combiné de votre téléphone près de votre oreille que lorsqu'il est en mode de conversation normal.
18. Les adaptateurs d'alimentation sont destinés à être correctement orientés en position verticale ou au sol. Les broches ne sont pas conçues pour maintenir la fiche en place si elle est branchée au plafond, sous la table ou dans une prise de courant d'armoire.
19. Utilisez uniquement le cordon d'alimentation et les piles indiqués dans ce manuel. Ne jetez pas les piles au feu. Elles risquent d'exploser. Vérifiez auprès des autorités locales les éventuelles instructions spéciales d'élimination.
20. En position de montage mural, veillez à monter le socle du téléphone sur le mur en alignant les oeilletons avec les montants de fixation de la plaque murale. Ensuite, faites glisser le socle téléphonique vers le bas sur les deux montants de montage jusqu'à ce qu'il se verrouille en place. Reportez-vous aux instructions complètes dans la section Installation du guide d'utilisation.
21. Listé POE (Le produit est considéré comme peu susceptible de nécessiter une connexion à un réseau Ethernet avec un routage extérieur à l'installation).



#### MISE EN GARDE

- Gardez les petits objets métalliques tels que les épingles et les agrafes loin du combiné.
- Il peut y avoir un risque d'explosion si un mauvais type de pile de combiné est utilisé (CTM-2115). Utilisez uniquement la pile rechargeable fournie (BT164392/ BT264392) ou une pile de remplacement (BT264392). Éliminez les piles usagées conformément aux informations figurant dans le sceau RBRCMD de ce guide d'utilisation

## CONSERVEZ CES INSTRUCTIONS

## Parts Checklist

Your package contains the following items. Save your sales receipt and original packaging in the event warranty service is necessary.

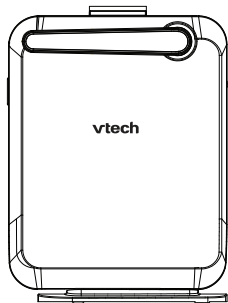

Base Station



Base Station  
wall-mounting plate



Cordless Handset and  
Handset Battery  
(preinstalled in the handset)

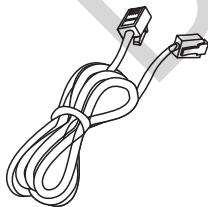

Ethernet Cable

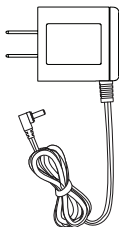

Handset Charger  
Adapter

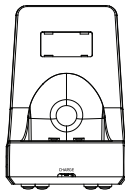

Handset Charger

## Base Station Layout

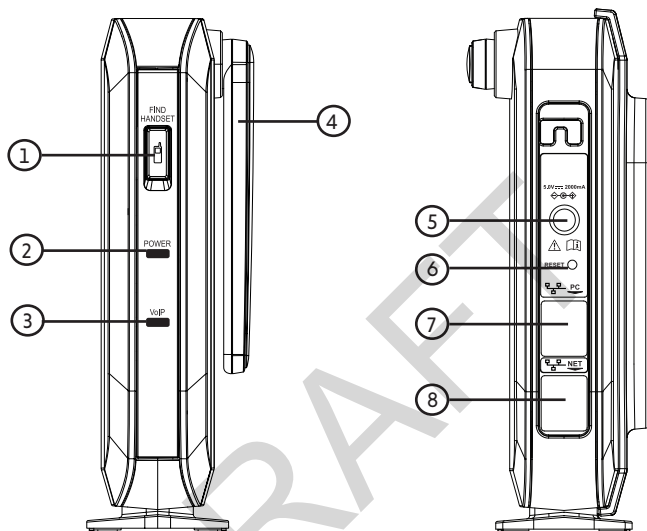





1	<b>FIND HANDSET</b> button. <ul style="list-style-type: none"><li>• Short press (for less than 2 seconds) to find the handset by making it ring. Short press again to stop handset ringing.</li><li>• Short press (for less than 2 seconds) ten times, then long press (between 5 and 10 seconds) to restore the phone's factory defaults.</li></ul>
2	<b>POWER</b> LED
3	<b>VoIP</b> LED
4	Antenna
5	AC adapter input
6	Reset button. Short press (for less than 2 seconds) to reboot the phone.
7	PC port
8	Ethernet port

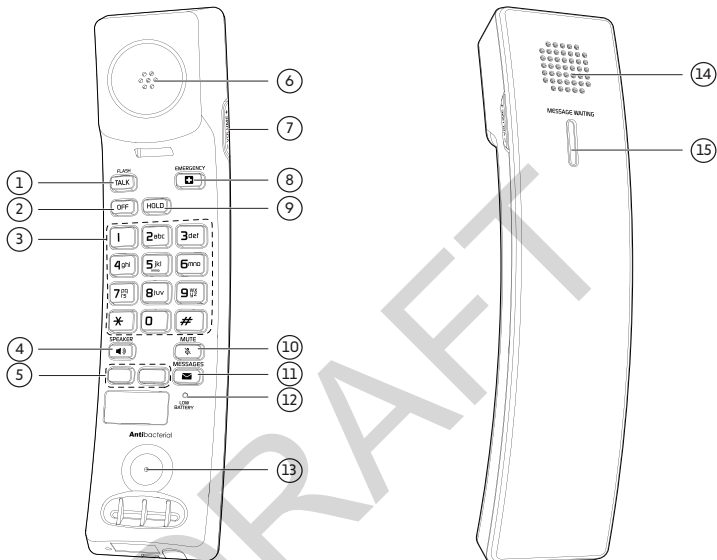

## Cordless Handset Layout



1	<b>FLASH/TALK</b>
2	<b>OFF</b>
3	Numeric dial keys
4	<b>SPEAKER</b>  key
5	Speed dial keys
	Programmable key #1 Programmable key #2
6	Handset earpiece

7	<b>VOLUME +/-</b>
8	<b>EMERGENCY</b> 
9	<b>HOLD</b>
10	<b>MUTE</b> 
11	<b>MESSAGES</b> 
12	Low battery LED
13	Microphone
14	Speaker
15	<b>MESSAGE WAITING</b> LED

## Cordless Handset Charger Layout

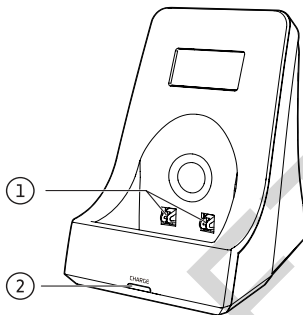

1	Charging poles
2	<b>CHARGE LED</b>

## Base Station Installation

This section assumes that your network infrastructure is established and that your IP PBX phone service has been ordered and configured for your location. For more information about IP PBX configuration, please refer to the SIP Phone Configuration Guide.

You can power the base station using a compatible VTech power adapter (sold separately) or using Power over Ethernet (PoE Class 2) from your network. If you are not using PoE, install the base station near a power outlet not controlled by a wall switch. The base station can be placed on a flat surface or mounted on a wall in a vertical or horizontal orientation.

### To install the base station:

1. Plug one end of the Ethernet cable into the Ethernet port on the rear of the base station (marked by  NET), and plug the other end of the cable into your network router or switch.
2. If the base station is not using power from a PoE-capable network router or switch:
  - a. Connect the supplied power adapter to the base station power jack.
  - b. Plug the power adapter into an electrical outlet that is not controlled by a wall switch.

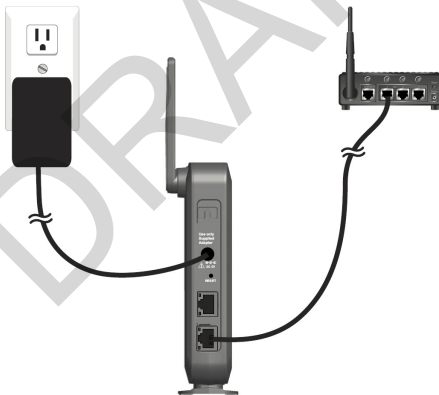

### IMPORTANT INFORMATION

1. Use only a compatible VTech power adapter. To order a replacement power adapter, call **1 (888) 907-2007**.
2. The power adapter is intended to be correctly oriented in a vertical or floor mount position. The prongs are not designed to hold the plug in place if it is plugged into a ceiling, under-the-table or cabinet outlet.

### To mount the base station on a wall:

1. Install two mounting screws on the wall. Choose screws with heads larger than 5 mm (3/16 inch) in diameter (1 cm / 3/8 inch diameter maximum). The screw centers should be 5 cm (1 15/16 inches) apart vertically or horizontally.

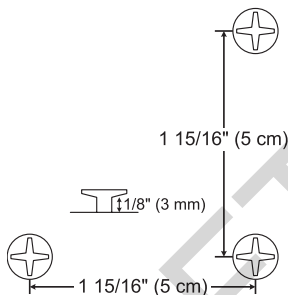

2. Tighten screws until only 3 mm (1/8 inch) of the screws are exposed.
3. Attach the mounting plate to the top of the base station. Insert the tab into the slot and then push the plate in at the bottom of the base station until the mounting plate clicks into place.



4. Check to make sure the plate is secure at top and bottom. It should be flush with the base station body.

5. Place the base station over the mounting screws.

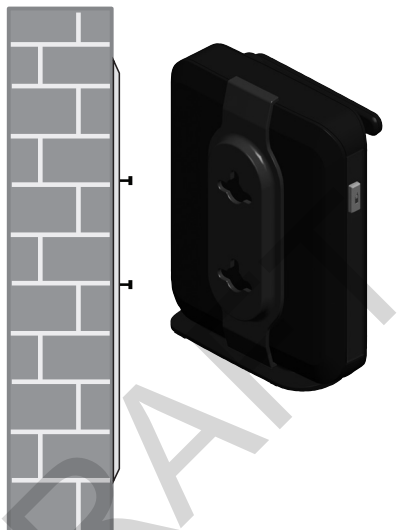

6. Connect the Ethernet cable and power as described on page 11.

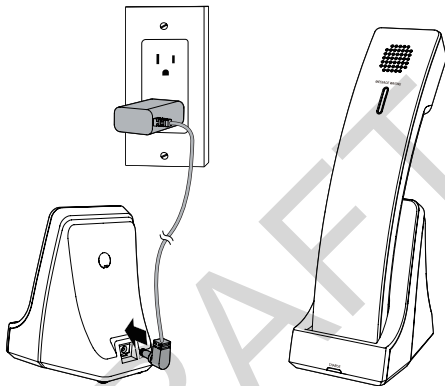

## Handset Charger Installation

1. Install the handset charger as shown below.
  - Make sure the supplied power adapter is securely plugged into an outlet not controlled by a wall switch.

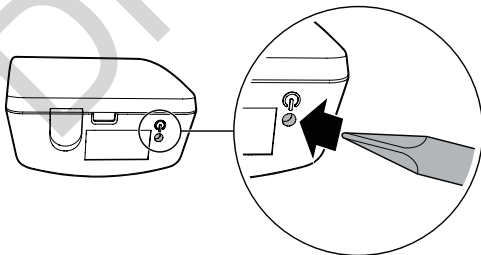

2. Bend a small paperclip and gently insert it in the handset battery ON pinhole to turn on the cordless handset.



- Without turning on the battery, the handset cannot be charged or operated.
  - The battery is fully charged after 16 hours of continuous charging. For best performance, keep the handset in the charging base when not in use.
3. On the handset, press /SPEAKER. Listen for a dial tone, and then press /SPEAKER again to hang up.

## CAUTIONS

Use only the supplied power adapter. The supplied power adapter is not designed for use in any other devices. Misuse of it on your other devices shall be prohibited. To order a replacement, call 1-888-907-2007.

## Installation Notes

Avoid placing the base station, handset, or handset charger too close to:

- Communication devices such as television sets, DVD players, or other cordless telephones
- Excessive heat sources
- Noise sources such as a window with traffic outside, motors, microwave ovens, refrigerators, or fluorescent lighting
- Excessive dust sources such as a workshop or garage
- Excessive moisture
- Extremely low temperature
- Mechanical vibration or shock such as on top of a washing machine or work bench

## Handset Registration

Your cordless handset is preregistered to the base station. You do not need to register your cordless handset.

You can register additional cordless handsets to the base station. The Base station accommodates up to four CTM-C4402 cordless handsets.

1. On the base station, press the FIND HANDSET button for four seconds, then release the button. Both LEDs on the base station begin to flash.
2. On the cordless handset, press the key sequence: **1 2 3 MUTE**.

When the registration process completes, the **MESSAGE WAITING** LED flashes once, and you hear three rising beeps as confirmation.

## Handset Deregistration

1. When a registered cordless handset is idle, press the key sequence:  
**\* 3 3 1 7 3 4 # MUTE**.

When the deregistration process completes, you hear a confirmation tone.

2. To reset the cordless handset to factory settings, press the key sequence:  
**\* 8 8 3 2 4 7 # MUTE**.

## Finding your phone's IP address

If you want to use the Web User Interface to configure the phone, you need to know the phone's IP address. You can obtain the phone's IP address using either of the following methods: \*

### Voice Menu

1. When the phone is idle, press this key sequence on the handset: **TALK \* \* \* \***.  
A digitized voice on the handset will announce Voice Menu options.
2. Press **1** for network configuration.
3. Press **2** for IP address.  
A digitized voice on the handset will announce the IP address.

### Administration Tool

1. Run the VTech Hotel SIP Phone Admin Tool on a computer with access to your SIP network.
2. Enter the **Start IP** and **End IP** range to search, and then click **>**.

You should consult with your network administrator for the IP range used at your installation.

Hotel SIP Phone Administration Tool v4.1.2.9

File Tools

**vtech**

IP Range

Single IP:  >

Start IP :  >

End IP :  >

Start IP	End IP
----------	--------

Remove

Refresh

3. Click the IP range in the table, and then click **Refresh**.



Hotel SIP Phone Administration Tool v4.1.2.9

File Tools

# vtech

IP Range

Single IP :  >

Start IP :  >

End IP :

Start IP	End IP
10.91.20.60	10.91.20.90

Remove

Refresh

4. Under **Select target models**, select the **CTM-S2115** checkbox.

Select target models and enter administrator password

1. Select target models

<input type="checkbox"/> CTM-S2110	<input type="checkbox"/> S2211
<input checked="" type="checkbox"/> <b>CTM-S2115</b>	<input type="checkbox"/> S2211-L
<input type="checkbox"/> CTM-S2120	<input type="checkbox"/> S2220-L
<input type="checkbox"/> CTM-S2125	<input type="checkbox"/> S2221-L
<input type="checkbox"/> CTM-S2312	<input type="checkbox"/> S2310

5. Enter your **Password**, and then click **Apply**. The default password is admin. The Admin tool begins scanning IP addresses. As the scan proceeds, the list of devices is updated.
6. Look for your phone's MAC Address. The table entry will display the phone's IP address. Check the MAC Address against the LAN MAC or the WIFI MAC, depending on which connection (LAN or WIFI) is in use. The labels of both LAN and WIFI MAC are pasted on the base station.

ension	MAC Address	IP Address	Status	BS Current Firmware	Model Number	C
	EE:D0:66:2D:B6:07	10.91.20.60	Unregistered	0.1.0-15-g961a0468	M500	
	<b>14:AE:DB:E8:9A:55</b>	<b>10.91.20.87</b>	Registered	0.0.2.0	CTM-S2115	0.

## Voice Menu

The Voice menu enables you to use the handset to query and change phone settings.

### To access the Voice Menu:

1. When the phone is idle, press this key sequence on the handset: **TALK \* \* \* \* .**  
A digitized voice on the handset will announce Voice Menu options.
2. Press the number key on the handset to select the desired menu option, or enter information. A list of menu options is shown in the diagram below.  
For example, to find out the IP address of the phone, press **1** for Network Configuration, then press **2** for IP Address.
3. When you are finished with the Voice menu, press **OFF** on the handset or place it in the handset charger.

**NOTE:** If you changed any network settings, your phone will automatically reboot. This will enable your new settings to take effect.

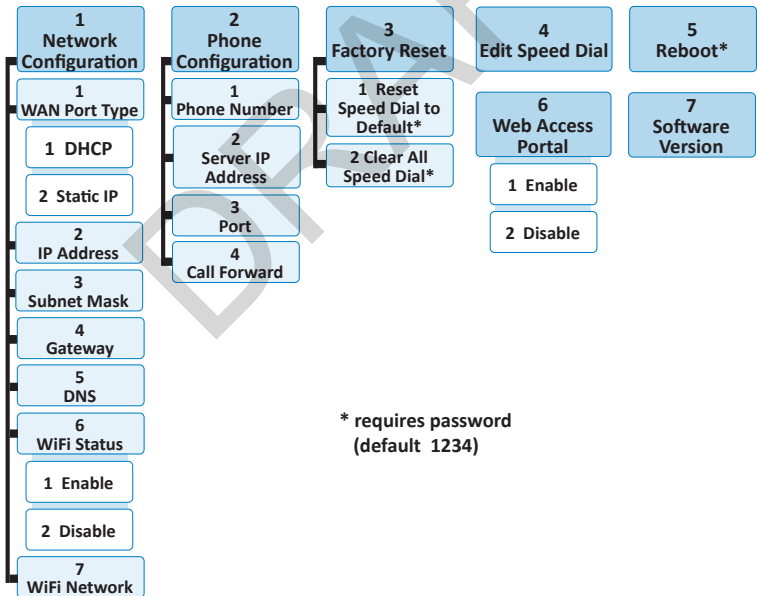

## Handset Battery Charging

The battery must be fully charged before using the cordless handset for the first time. The **CHARGE** LED turns on when the handset is charging on the telephone base, charging base or charging stand. The battery is fully charged after 16 hours of continuous charging. For best performance, keep the cordless handset in the telephone base, charging base or charging stand when not in use.

## Replacing a Cordless Handset Battery

The cordless handset battery is preinstalled. To replace the cordless handset battery, follow the steps below.

1. Use a narrow object to pry open the screw cover and remove the screw with cross head screwdriver. Then, insert a 5 mm standard flat head screwdriver in the provided slot and gently open the handset cover.

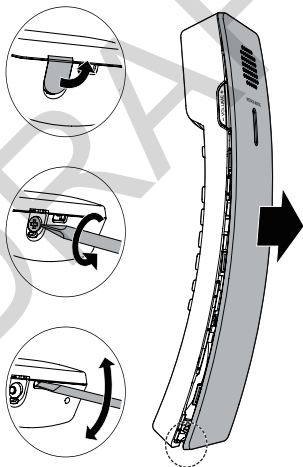

2. Unplug the battery connector from the socket and then remove the battery from the handset battery compartment.
3. Plug the battery connector securely into the socket inside the handset battery compartment. Place the battery with the label THIS SIDE UP facing up and the wires inside the battery compartment.

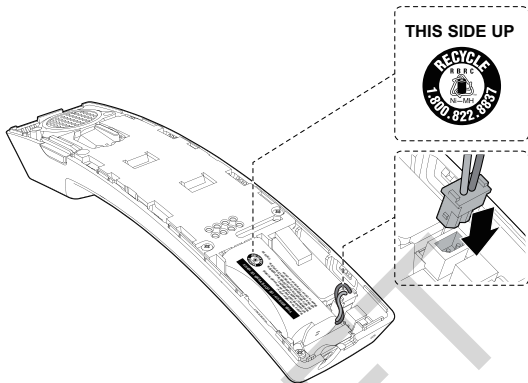

4. To replace the handset cover, align all the tabs on the handset cover against the corresponding grooves on the handset, then firmly push downward until all the tabs lock in the grooves. Then install the screw.

#### **!** CAUTIONS

- There may be a risk of explosion if a wrong type of handset battery is used. Use only the supplied rechargeable battery (BT164392/BT264392) or replacement battery (BT264392). To order a replacement, call **1-888-907-2007**.
- FCC ID is shown on the back of the cordless handset body after the handset cover is removed.
- Dispose of used batteries according to the information in The RBRC® seal.

## Precautions for users of implanted cardiac pacemakers

Cardiac pacemakers (applies only to digital cordless telephones):

Wireless Technology Research, LLC (WTR), an independent research entity, led a multidisciplinary evaluation of the interference between portable wireless telephones and implanted cardiac pacemakers. Supported by the U.S. Food and Drug Administration, WTR recommends to physicians that:

Pacemaker patients

- Should keep wireless telephones at least six inches from the pacemaker.
- Should NOT place wireless telephones directly over the pacemaker, such as in a breast pocket, when it is turned ON.
- Should use the wireless telephone at the ear opposite the pacemaker.

WTR's evaluation did not identify any risk to bystanders with pacemakers from other persons using wireless telephones.

## Operating range

The cordless telephone operates with the maximum power allowed by the Federal Communications Commission (FCC). Even so, the cordless handset and telephone base can communicate over only a certain distance - which can vary with the locations of the telephone base, cordless handset, the weather, and the layout of the hotel.

When the cordless handset is out of range while on a call, the cordless handset rapidly beeps three times.

If there is a call while the handset is out of range, it may not ring, or if it does ring, the call may not connect well when you answer the call. Move closer to the telephone base to answer the call.

If the handset moves out of range during a telephone conversation, there may be interference.

To improve reception, move closer to the telephone base.

## About cordless telephones

Privacy: The same features that make a cordless telephone convenient create some limitations. Telephone calls are transmitted between the telephone base and the cordless handset by radio waves, so there is a possibility that the cordless telephone conversations could be intercepted by radio receiving equipment within range of the cordless handset. For this reason, you should not think of cordless telephone conversations as being as private as those on corded telephones.

**Electrical power:** The telephone base of the cordless telephone must be connected to a working electrical outlet. The electrical outlet should not be controlled by a wall switch. Calls cannot be made from the cordless handset if the telephone base is unplugged, switched off or if the electrical power is interrupted.

**Potential TV interference:** Some cordless telephones operate at frequencies that may cause interference to televisions and VCRs. To minimize or prevent such interference, do not place the telephone base of the cordless telephone near or on top of a TV or VCR. If interference is experienced, moving the cordless telephone farther away from the TV or VCR often reduces or eliminates the interference.

**Rechargeable batteries:** Exercise care in handling batteries in order not to create a short circuit with conducting material such as rings, bracelets and keys. The battery or conductor may overheat and cause harm. Observe proper polarity between the battery and the battery charger.

**Nickel-metal hydride rechargeable batteries:** Dispose of these batteries in a safe manner. Do not burn or puncture the battery. Like other batteries of this type, if burned or punctured, they could release caustic material which could cause injury.

## The RBRC® seal

The RBRC® seal on the nickel-metal hydride battery indicates that VTech Communications, Inc. is voluntarily participating in an industry program to collect and recycle these batteries at the end of their useful lives, when taken out of service within the United States and Canada.

The RBRC® program provides a convenient alternative to placing used nickel-metal hydride batteries into the trash or municipal waste, which may be illegal in your area.

VTech's participation in RBRC® makes it easy for you to drop off the spent battery at local retailers participating in the RBRC® program or at authorized VTech product service centers. Please call **1 (800) 8 BATTERY™** for information on Ni-MH battery recycling and disposal bans/ restrictions in your area. VTech's involvement in this program is part of its commitment to protecting our environment and conserving natural resources.

**RBRC® is a registered trademark of Rechargeable Battery Recycling Corporation.**



## **FCC, ACTA and IC regulations**

### **FCC Part 15**

This equipment has been tested and found to comply with the requirements for a Class B digital device under Part 15 of the Federal Communications Commission (FCC) rules. These requirements are intended to provide reasonable protection against harmful interference in a residential installation. This equipment generates, uses and can radiate radio frequency energy and, if not installed and used in accordance with the instructions, may cause harmful interference to radio communications. However, there is no guarantee that interference will not occur in a particular installation. If this equipment does cause harmful interference to radio or television reception, which can be determined by turning the equipment off and on, the user is encouraged to try to correct the interference by one or more of the following measures:

- Reorient or relocate the receiving antenna.
- Increase the separation between the equipment and receiver.
- Connect the equipment into an outlet on a circuit different from that to which the receiver is connected.
- Consult the dealer or an experienced radio/TV technician for help.

Changes or modifications to this equipment not expressly approved by the party responsible for compliance could void the user's authority to operate the equipment.

This device complies with Part 15 of the FCC rules. Operation is subject to the following two conditions: (1) this device may not cause harmful interference, and (2) this device must accept any interference received, including interference that may cause undesired operation.

This Class B digital apparatus complies with Canadian ICES-003. CAN ICES-3 (B)/NMB-3(B)

### **FCC Part 68 and ACTA**

This equipment complies with Part 68 of the FCC rules and with technical requirements adopted by the Administrative Council for Terminal Attachments (ACTA). The label on the back or bottom of this equipment contains, among other things, a product identifier in the format US:AAAKXNANXXXX. This identifier must be provided to your telephone service provider upon request.

The plug and jack used to connect this equipment to premises wiring and the telephone network must comply with applicable Part 68 rules and technical requirements adopted by ACTA. A compliant telephone cord and modular plug is provided with this product. It is designed to be connected to a compatible modular jack that is also compliant. An RJ45 jack should normally be used for connecting to a single line. See the installation

instructions in the user's manual.

The Ringer Equivalence Number (REN) is used to determine how many devices you may connect to your telephone line and still have them ring when you are called. The REN for this product is encoded as the 6th and 7th characters following the US: in the product identifier (e.g., if ## is 03, the REN is 0.3). In most, but not all areas, the sum of all RENs should be five (5.0) or less. For more information, please contact your telephone service provider.

This equipment may not be used with Party Lines. If you have specially wired alarm dialing equipment connected to your telephone line, ensure the connection of this equipment does not disable your alarm equipment. If you have questions about what will disable alarm equipment, consult your telephone service provider or a qualified installer.

If this equipment is malfunctioning, it must be unplugged from the modular jack until the problem has been corrected. Repairs to this telephone equipment can only be made by the manufacturer or its authorized agents. For repair procedures, follow the instructions outlined under **VTech Hospitality limited warranty program** in the user's manual.

To ensure safety of users, the FCC has established criteria for the amount of radio frequency energy of the product. This product has been tested and found to comply with the FCC criteria. The handset may be safely held against the ear of the user. The telephone base shall be installed and used such that parts of the user's body other than the hands are maintained at a distance of approximately 20 cm (8 inches) or more.

If this equipment is causing harm to the telephone network, your telephone service provider may temporarily discontinue your telephone service. Your telephone service provider is required to notify you before interrupting service. If advance notice is not practical, you will be notified as soon as possible. You will be given the opportunity to correct the problem and your telephone service provider is required to inform you of your right to file a complaint with the FCC. Your telephone service provider may make changes in its facilities, equipment, operation, or procedures that could affect the proper functioning of this product. Your telephone service provider is required to notify you if such changes are planned.

If this product is equipped with a corded or cordless handset, it is hearing aid compatible.

If this product has memory dialing locations, you may choose to store emergency telephone numbers (e.g., police, fire, medical) in these locations. If you do store or test emergency numbers, please:

Remain on the line and briefly explain the reason for the call before hanging up.

Perform such activities in off-peak hours, such as early morning or late evening.

When the adjunct is used with a leased system, permission of the owner of the equipment must be obtained for connection of the adjunct because modification of the host system is often required.



This product can only be connected to the host equipment and never directly to the network.

## Industry Canada

This product meets the applicable Innovation, Science and Economic Development Canada technical specifications.

The Ringer Equivalence Number (REN) is an indication of the maximum number of devices allowed to be connected to a telephone interface. The termination of an interface may consist of any combination of devices subject only to the requirement that the sum of the RENs of all the devices not exceed five.

Le présent matériel est conforme aux spécifications techniques applicables d'Innovation, Sciences et Développement économique Canada.

L'indice d'équivalence de la sonnerie (IES) sert à indiquer le nombre maximal de terminaux qui peuvent être raccordés à une interface téléphonique. La terminaison d'une interface peut consister en une combinaison quelconque de dispositifs, à la seule condition que la somme d'indices d'équivalence de la sonnerie de tous les dispositifs n'excède pas cinq.

## ISED Warning

This device complies with Innovation, Science, and Economic Development Canada licence exempt RSS standard(s). Operation is subject to the following two conditions:

1. This device may not cause interference, and
2. This device must accept any interference, including interference that may cause undesired operation of the device.

Privacy of communications may not be ensured when using this telephone.

The device of base unit is in compliance with RF exposure guidelines, users can obtain Canadian information on RF exposure and compliance. The minimum distance from body to use the device is 20cm.

The device of handset unit has been tested and complies with ISED SAR limits.

## Avertissement ISED

Cet appareil est compatible avec la licence de l'Innovation, la Science et le développement économique du Canada à l'exemption des normes RSS. Le fonctionnement est sujet aux deux (2) conditions suivantes :

- (1) Cet appareil peut ne pas causer de l'interférence, et
- (2) Cet appareil doit accepter l'interférence, incluant de l'interférence qui peut causer un mauvais fonctionnement de cet appareil.

La confidentialité des communications peut ne pas être garantie lors de l'utilisation de ce téléphone.

L'appareil de l'unité de base est conforme aux directives d'exposition aux RF. Après examen de ce matériel aux conformités ou aux limites d'intensité de champ RF, les utilisateurs peuvent sur l'exposition aux radiofréquences et la conformité d'acquérir les informations correspondantes. La distance minimale du corps à utiliser le dispositif est de 20cm.

L'appareil du combiné a été testé et est conforme aux restrictions ISEDC SAR.

## **Maintenance**

### **TAKING CARE OF YOUR TELEPHONE**

Your telephone contains sophisticated electronic parts, so it must be treated with care.

### **AVOID ROUGH TREATMENT**

Place the handset down gently. Save the original packing materials to protect your telephone if you ever need to ship it.

### **AVOID WATER**

Your telephone can be damaged if it gets wet. Do not use the handset outdoors in the rain, or handle it with wet hands. Do not install the telephone base near a sink, bathtub or shower.

### **ELECTRICAL STORMS**

Electrical storms can sometimes cause power surges harmful to electronic equipment. For your own safety, take caution when using electrical appliances during storms.

### **CLEANING YOUR TELEPHONE**

Your telephone has a durable plastic casing that should retain its luster for many years. Clean it only with a soft cloth slightly dampened with water or mild soap. Do not use excess water or cleaning solvents of any kind.

## **Disclaimer and Limitation of Liability**

VTech Communications, Inc. and its suppliers assume no responsibility for any damage or loss resulting from the use of this user's manual. VTech Communications, Inc. and its suppliers assume no responsibility for any loss or claims by third parties that may arise through the use of this product. VTech Communications, Inc. and its suppliers assume no responsibility for any damage or loss caused by deletion of data as a result of malfunction, dead battery, or repairs. Be sure to make backup copies of important data on other media to protect against data loss.

**Company:** VTech Communications, Inc.

**Address:** 9020 SW Washington Square Road., Suite 555, Tigard, OR 97223, United States

**Phone:** 1 (888) 907-2007

REMEMBER THAT ELECTRICAL APPLIANCES CAN CAUSE SERIOUS INJURY IF USED WHEN YOU ARE WET OR STANDING IN WATER. IF THE TELEPHONE BASE SHOULD FALL INTO WATER, DO NOT RETRIEVE IT UNTIL YOU UNPLUG THE POWER CORD AND/OR TELEPHONE LINE CORD FROM THE WALL. THEN REMOVE THE TELEPHONE BY THE UNPLUGGED CORDS.

## Technical Specifications

### Base Station

Transmit frequency	1921.536–1928.448 MHz
Channels	5
Nominal effective range	Maximum power allowed by FCC and IC. Actual operating range may vary according to environmental conditions at the time of use.
Operating temperature	32–104 °F (0–40 °C)
Power requirement	Power over Ethernet (PoE): IEEE 802.3at supported, class 2 If PoE not available, power adapter (sold separately): S006AKU0500080 Input: 100-240V AC 50/60Hz Output: 5.0V DC @ 800mA
Ethernet network port	Two 10/100 Mbps RJ-45 ports

### Handset

Frequency control	Crystal controlled PLL synthesizer
Transmit frequency	1921.536–1928.448 MHz
Channels	5
Nominal effective range	Maximum power allowed by FCC and IC. Actual operating range may vary according to environmental conditions at the time of use.
Operating temperature	32–104 °F (0–40 °C)
Power requirement	Handset battery (BT164392/BT264392): 2.4V 550 mA, Ni-MH battery pack Handset charger: supplied power adapter: VT05UUS06040 Input: 100-120V AC 60 Hz Output: 6V DC @ 400 mA

DRAFT



Specifications are subject to change without notice.  
Copyright © 2021  
VTech Telecommunications, Inc.  
All Rights Reserved.  
CTM-S2115\_QSG\_V1\_CEC\_20210106