

Specific Absorption Rate (SAR) Test Report
for
Vtech Telecommunications Ltd.
on the
1.9GHz DECT 6.0 Hospitality Cordless Phone
Model Number: A1420

Test Report: TS10080130-EME
Date of Report: Aug. 25, 2010
Date of test: Aug. 24, 2010
Review Date: Aug. 26, 2010

Total No of Pages Contained in this Report: 68



The test report was prepared by:

Sign on File
Shirla Hsiao / Officer

These measurements were taken by:

Sign on File
Fred Yu / Engineer

The test report was reviewed by:

Name Rex Liao
Title Engineer

All services undertaken are subject to the following general policy: Reports are submitted for exclusive use of the client to whom they are addressed. Their significance is subject to the adequacy and representative character of the samples and to the comprehensiveness of the tests, examinations or surveys made. This report shall not be reproduced except in full, without written consent of Intertek Testing Services, Taiwan Ltd.

Table of Contents

1.0 General information	3
2.0 SAR Evaluation.....	7
3.0 Test Instruments and Tissue Liquids	17
4.0 Measurement Uncertainty	21
5.0 Test Results.....	23
6.0 E-Field Probe and 1900 Dipole Antenna Calibration	24
7.0 WARNING LABEL INFORMATION - USA	24
8.0 REFERENCES	24
9.0 DOCUMENT HISTORY	25
APPENDIX A - SAR Evaluation Data	26
APPENDIX B - Photographs.....	35
APPENDIX C - E-Field Probe and 1900MHz Dipole Antenna Calibration Data.....	39

1.0 General information

The A1420 handset supplied for Specific Absorption Rate (SAR) testing is a 1.9GHz DECT 6.0 Hospitality Cordless Phone device.

The device was tested at the facility of Intertek Testing Services in Hsinchu, Taiwan. The maximum output power declared by Vtech Telecommunications Ltd.

EUT model #A1420 was evaluated in accordance with the requirements for compliance testing defined in FCC OET Bulletin 65 Supplement C (Edition 01-01), RSS-102 and meet the SAR requirement.

For the evaluation, the dosimetric assessment system INDEXSAR SARA2 was used. The phantom employed was the head Specific Anthropomorphic Mannequin (SAM) phantom. The total uncertainty for the evaluation of the spatial peak SAR values averaged over a cube of 1g tissue mass had been assessed for this system to be $\pm 20.6\%$.

SAR testing was performed at both the left and right ear of the phantom at the two-handset positions stated in the specification. Testing was performed at the middle frequency of 1900 band with a rechargeable battery and in Normal mode of operation.

Any accessories supplied with A1420 have also been tested.

In summary, the maximum spatial peak SAR value for the sample device averaged over 1g was found to be:

Phantom	Worst Case Position	SAR _{1g} , W/kg
Head Specific Anthropomorphic Mannequin (SAM) phantom	EUT Right Cheek to the phantom	0.011 W/kg

In conclusion, the tested Sample device was found to be in compliance with the requirements defined in OET Bulletin 65 Supplement C (Edition 01-01) and RSS-102 for head configurations.

1.1 Client Information

The 1.9GHz DECT 6.0 Hospitality Cordless Phone has been tested at the request of:

Applicant: Vtech Telecommunications Ltd.
23/F, Tai Ping Industrial Centre, Block 1, 57 Ting Kok Road, Tai Po, Hong Kong

1.2 Equipment under test (EUT)

Product Descriptions:

Equipment	1.9GHz DECT 6.0 Hospitality Cordless Phone		
Trade Name	Vtech	Model No.	A1420
FCC ID	EW780-H006-00	S/N No.	Not Labeled
Category	Portable	RF Exposure	Uncontrolled Environment
Frequency Band	1921.536 -1928.448 MHz	System / Power Level	DECT

EUT Antenna Description			
Type	Integral	Configuration	Fixed
Dimensions	36 mm length	Gain	0 dBi
Location	Embedded		

Use of product: 1.9GHz DECT 6.0 Hospitality Cordless Phone

Manufacturer: Dongguan VTech Satellite Equipment Co.Ltd.

Production is planned: Yes, No

EUT receive date: Aug. 19, 2010

EUT received condition: Good operating condition prototype

EUT status: Normal mode

Test start date: Aug. 24, 2010

Test end date: Aug. 24, 2010

1.3 Modifications required for compliance

The EUT has no modifications during test.

1.4 System test configuration

1.4.1 System block diagram & Support equipment

Support Equipment			
Item #	Equipment	Model No.	S/N
1	Base unit	A1420	N/A



1.4.2 Test Position

See the photographs as section 2.2

1.4.3 Test Condition

During tests the worst-case data (max RF coupling) was determined with following conditions:

Usage	Operated in normal mode with Base unit which provided by client	Distance between antenna axis at the joint and the liquid surface:	Handset is touching and tilting the Head Phantom in right and left position	
Simulating human Head / Body	Head	EUT Battery	Fully-charged with 1 set rechargeable battery	
Conducted output power	Channel	Frequency MHz	Before SAR Test (dBm)	After SAR Test (dBm)
	Mid Channel	1924.992	20.39	20.38

The spatial peak SAR values were assessed for middle operating channel, defined by the manufacturer.

2.0 SAR Evaluation

2.1 SAR Limits

The following FCC limits (IEEE C95.1 2005) for SAR apply to devices operate in General Population/Uncontrolled Exposure environment:

EXPOSURE (General Population/Uncontrolled Exposure environment)	SAR (W/kg)
Average over the whole body	0.08
Spatial Peak (1g)	1.60
Spatial Peak for hands, wrists, feet and ankles (10g)	4.00

2.2 Configuration Photographs

Test System: Head Simulator

Cheek Position of Left Ear



Tilt Position of Left Ear

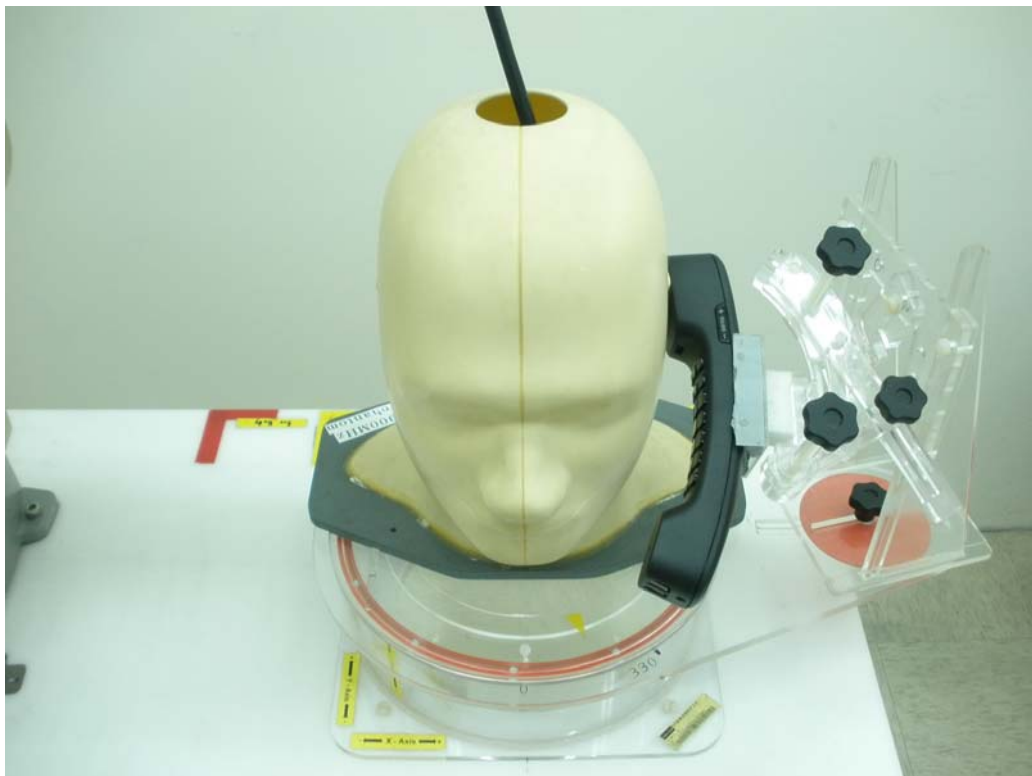

Cheek Position of Right Ear



Tilt Position of Right Ear



2.3 SAR measurement system

Robot system specification

The SAR measurement system being used is the IndexSAR SARA2 system, which consists of a Mitsubishi RV-E2 6-axis robot arm and controller, IndexSAR probe, amplifier and the phantom with Head or Box Shape. The robot is used to articulate the probe to programmed positions inside the phantom head to obtain the SAR readings from the DUT.

The system is controlled remotely from a PC, which contains the software to control the robot and data acquisition equipment. The software also displays the data obtained from test scans.

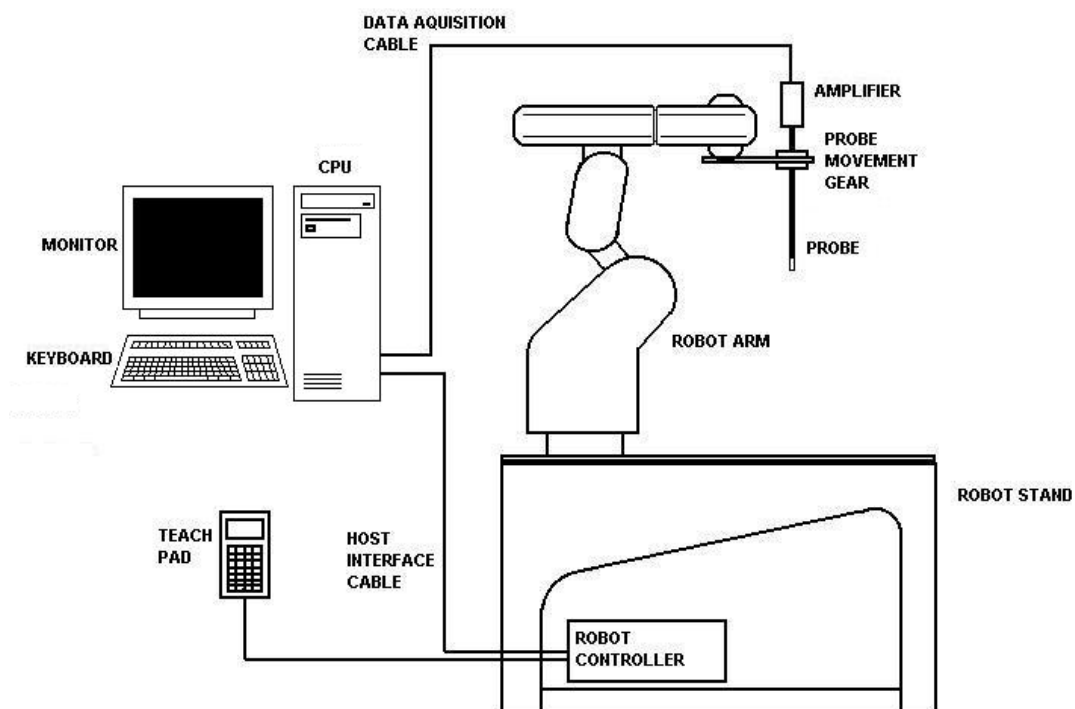

Figure 1: Schematic diagram of the SAR measurement system

The position and digitized shape of the phantom heads are made available to the software for accurate positioning of the probe and reduction of set-up time.

The SAM phantom heads are individually digitized using a Mitutoyo CMM machine to a precision of 0.02mm. The data is then converted into a shape format for the software, providing an accurate description of the phantom shell.

In operation, the system first does an area (2D) scan at a fixed depth within the liquid from the inside wall of the phantom scanning area is greater than the projection of EUT and antenna. When the maximum SAR point has been found, the system will then carry out a 3D scan centred at that point to determine volume averaged SAR level. The first 2 measurements points in a direction perpendicular to the surface of the phantom during the zoom scan and closest to the phantom surface, were only 3.5mm and the probe is kept at greater than half a diameter from the surface Probe specification.

IndexSar isotropic immersible SAR probe

The probe contains three orthogonal dipole sensors arranged on a triangular prism core, protected against static charges by PEEK cylindrical enclosure material.

Probe amplifier specification

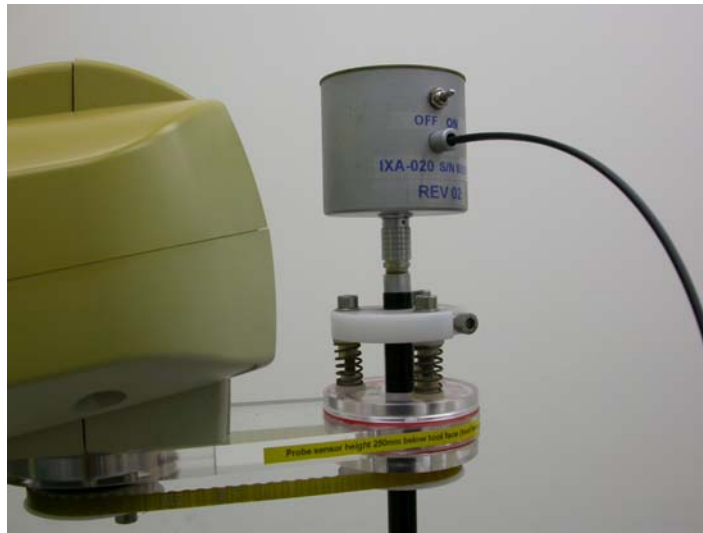

This amplifier has a time constant of approx. 50 μ s, which is much faster than the SAR probe response time. The overall system time constant is therefore that of the probe (<1ms) and reading sets for all three channels (simultaneously) are returned every 2ms to the PC. The conversion period is approx. 1 μ s at the start of each 2ms period. This enables the probe to follow pulse modulated signals of periods >>2ms. The PC software applies the linearisation procedure separately to each reading, so no linearisation corrections for the averaging of modulated signals are needed in this case. It is important to ensure that the probe reading frequency and the pulse period are not synchronised and the behaviour with pulses of short duration in comparison with the measurement interval need additional consideration.

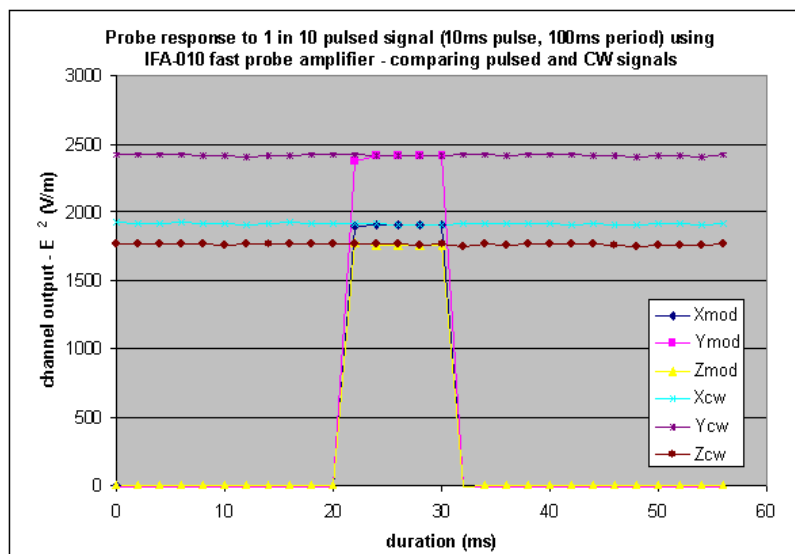

2.3.1 SAR measurement procedure

a. SARA2 interpolation and extrapolation schemes

SARA2 software contains support for both 2D cubic B-spline interpolation as well as 3D cubic B-spline interpolation. Additionally, for extrapolation purposes, a general n-th order polynomial fitting routine is implemented following a singular value decomposition algorithm presented in [4]. A 4th order polynomial fit is used by default for data extrapolation, but a linear-logarithmic fitting function can be selected as an option. The polynomial fitting procedures have been tested by comparing the fitting coefficients generated by the SARA2 procedures with those obtained using the polynomial fit functions of Microsoft Excel when applied to the same test input data.

b. Interpolation of 2D area scan

The 2D cubic B-spline interpolation is used after the initial area scan at fixed distance from the phantom shell wall. The initial scan data are collected with approx. 10mm spatial resolution and spline interpolation is used to find the location of the local maximum to within a 1mm resolution for positioning the subsequent 3D scanning.

c. Extrapolation of 3D scan

For the 3D scan, data are collected on a spatially regular 3D grid having (by default) 6.4 mm steps in the lateral dimensions and 3.5 mm steps in the depth direction (away from the source). SARA2 enables full control over the selection of alternative steps in all directions.

The digitised shape of the head is available to the SARA2 software, which decides which points in the 3D array are sufficiently well within the shell wall to be “visited” by the SAR probe. After the data collection, the data are extrapolated in the depth direction to assign values to points in the 3D array closer to the shell wall. A notional extrapolation value is also assigned to the first point outside the shell wall so that subsequent interpolation schemes will be applicable right up to the shell wall boundary.

d. Interpolation of 3D scan and volume averaging

The procedure used for defining the shape of the volumes used for SAR averaging in the SARA2 software follow the method of adapting the surface of the “cube” to conform with the curved inner surface of the phantom (see Appendix D of FCC OET 65 Supplement C). This is called, here, the conformal scheme.

For each row of data in the depth direction, the data are extrapolated and interpolated to less than 1 mm spacing and average values are calculated from the phantom surface for the row of data over distances corresponding to the requisite depth for 10g and 1g cubes. This results in two 2D arrays of data, which are then cubic B-spline interpolated to sub mm lateral resolution. A search routine then moves an averaging square around through the 2D array and records the maximum value of corresponding 1g and 10g volume averages. For the definition of the surface in this procedure, the digitized position of the head shell surface is used for measurement in head-shaped phantoms. For measurements in rectangular, box phantom, the distance between the phantom wall and the closest set of grided data points is entered into the software. For measurements in box-shaped phantoms, this distance is under the control of the user. The effective distance must be greater than 2.5 mm as this is the tip-sensor distance and to avoid interface proximity effects, it should be at least 5 mm. A value of 6 or 8 mm is recommended. This distance is called **dbe**.

For automated measurements inside the head, the distance can't be less than 2.5mm, which is the radius of the probe tip and to avoid interface proximity effects, a minimum clearance distance of x mm is retained. The actual value of **dbe** will vary from point to point depending upon how the spatially-regular 3D grid points fit within the shell. The greatest separation is when a grid point is just not visited due to the probe tip dimensions. In this case the distance could be as large as the step-size plus the minimum clearance distance (i.e. with $x=5$ mm and a step size of 3.5, **dbe** will be between 3.5 and 8.5 mm).

The default step size (**dstep**) used is 3.5 mm, but this is under user-control. The compromise is with time of scan, so it's not practical to make it much smaller or scan times become long and power-drop influences become larger.

The robot positioning system specification for the repeatability of the positioning (**dss**) is +/- 0.04 mm.

The phantom shell is made by an industrial molding process from the CAD files of the SAM shape, with both internal and external molds. For upright phantoms, the external shape is subsequently digitized on a Mitutoyo CMM machine (Euro an ultrasonic sensor indicate that the shell thickness (**dph**) away from the eare is 2.0 ± 0.1 mm. the ultrasonic measurements were calibrated using additional mechanical measurements on available cut surfaces of the phantom shells.

For upright phantom, the alignment is based upon registration of the rotation axis of the phantom on its 253 mm diameter baseplate bearing and the position of the probe axis when commanded to go to the axial position. A laser alignment tool is provided (procedure detailed elsewhere). This enables the registration of the phantom tip (**dmis**) to be assured to within approx. 0.2mm. This alignment is done with reference to the actual probe tip after installation and probe alignment. The rotational positioning of the phantom is variable-offering advantages for special studies, but locating pins ensure accurate repositioning at the principal positions (LH and RH ears).

2.3.2 SAR measurement system validation

Routine record keeping procedures should be established for tracking the calibration and performance of SAR measurement system. When SAR measurements are performed, the entire measurement system should be checked daily within the device transmitting frequency ranges to verify system accuracy. A flat phantom irradiated by a half-wavelength dipole is typically used to verify the measurement accuracy of a system. When a radiating source is not available at the operating frequency range of the test device to verify system accuracy, a source operating within 100 MHz of the mid-band channel of each operating mode may be used. The measured one-gram SAR should be within 10% of the expected target values specified for the specific phantom and RF source used in the system verification measurement.

Procedures

The SAR evaluation was performed with the following procedures:

- a. The SAR distribution was measured at the exposed side of the bottom of the box phantom and was measured at a distance of 15 mm for 300 ~ 1000 MHz and 10 mm for 1000 ~ 3000 MHz from the inner surface of the shell. The feed power was 1/5W.
- b. The dimension for this cube is 32 mm x 32 mm x 34 mm was assessed by measuring 5 x 5 x 7 points. On the basis of this data set, the spatial peak SAR value was evaluated with the following procedure:
 - i) The data at the surface were extrapolated, since the center of the dipoles is 2.7 mm away from the tip of the probe and the distance between the surface and the lowest measurement point is 5 mm. The extrapolation was based on a least square algorithm. A polynomial of the fourth order was calculated through the points in Z-axes. This polynomial was then used to evaluate the points between the surface and the probe tip.
 - ii) The maximum interpolated value was searched with a straightforward algorithm. Around this maximum, the SAR values averaged over the spatial volumes (1g or 10g) were computed using the 3-D spline interpolation algorithm. The 3-D spline is composed of three one-dimensional splines with the "Not a knot" condition (in x, y and z directions). The volume was integrated with the trapezoidal algorithm. 1000 points (10 x 10 x 10) were interpolated to calculate the average.
 - iii) All neighboring volumes were evaluated until no neighboring volume with a higher average value was found.
- c. Re-measurements of the SAR value at the same location as in step a. above. If the value changed by more than 5 %, the evaluation was repeated.
- d. The test scan procedure for system validation also apply to the general scan procedure except for the set-up position. For general scan, the EUT was placed at the side of phantom. For validation scan, the dipole antenna was placed at the bottom of phantom

2.3.2.1 System Validation results

System Validation (1900 MHz)					
Frequency MHz	Liquid Type	Operating Mode	Target SAR _{1g} (W/kg)	Measured SAR _{1g} (W/kg)	Deviation (±10%)
1900	Head	CW	39.7*	38.475	-3.0856%

* the target was quoted from 1900 dipole antenna calibration report

Please see the plot below:

Date:	2010/8/24	Position:	bottom to phantom
Filename:	1900H validation.txt	Phantom:	HeadBox1-val..csv
Device Tested:	1900H validation	Head Rotation:	0
Antenna:	1900 dipole antenna	Test Frequency:	1900 MHz
Shape File:	none.csv	Power Level:	23 dBm

Probe:	0136																
Cal File:	SN0136_1900_HEAD																
Cal Factors:	<table border="1"> <tr> <th></th> <th>X</th> <th>Y</th> <th>Z</th> </tr> <tr> <td>Air</td> <td>459</td> <td>359</td> <td>382</td> </tr> <tr> <td>DCP</td> <td>20</td> <td>20</td> <td>20</td> </tr> <tr> <td>Lin</td> <td>.369</td> <td>.369</td> <td>.369</td> </tr> </table>		X	Y	Z	Air	459	359	382	DCP	20	20	20	Lin	.369	.369	.369
		X	Y	Z													
	Air	459	359	382													
	DCP	20	20	20													
Lin	.369	.369	.369														
Batteries Replaced:	2010/08/24																

Liquid:	15.5cm
Type:	1900 MHz Head
Conductivity:	1.3668
Relative Permittivity:	40.5146
Liquid Temp (deg C):	24
Ambient Temp (deg C):	24
Ambient RH (%):	50
Density (kg/m3):	1000
Software Version:	2.54

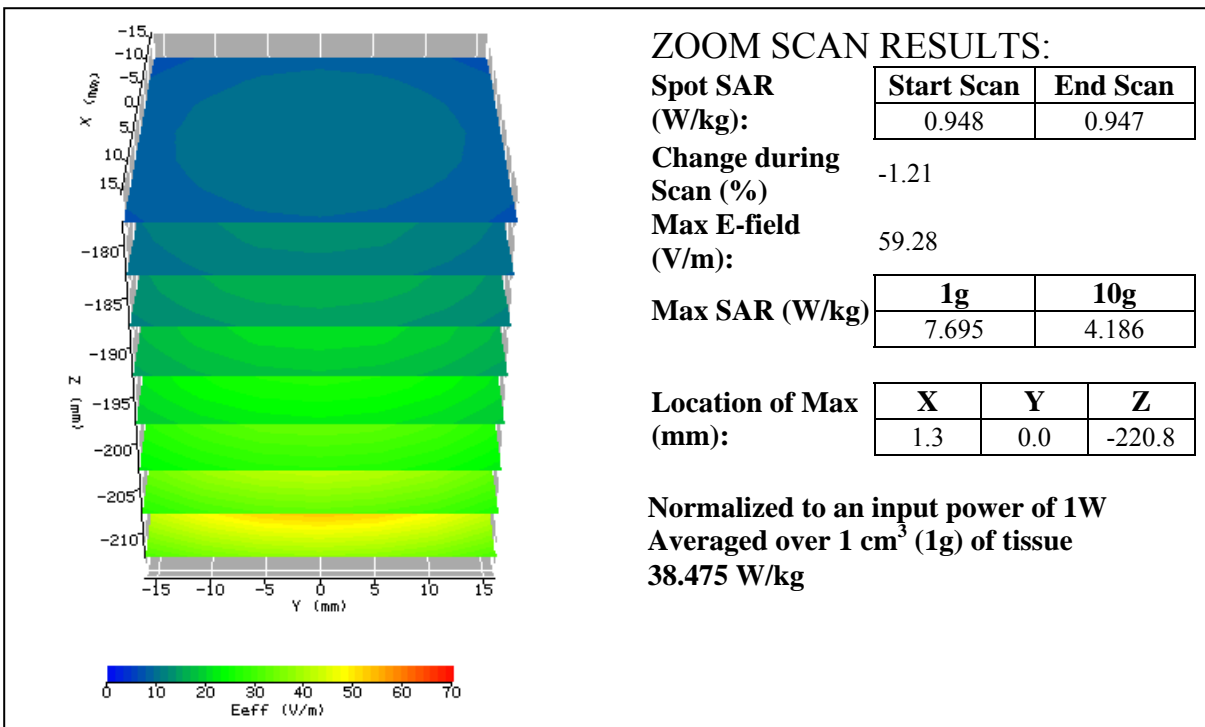

3.0 Test Instruments and Tissue Liquids

3.1 Instruments List

The Specific Absorption Rate (SAR) tests were performed with the INDEXSAR SARA2 SYSTEM.

The following major equipment/components were used for the SAR evaluations:

SAR Measurement System			
EQUIPMENT	SPECIFICATIONS	Intertek ID No.	LAST CAL. DATE
Balanced Validation Dipole Antenna	1900MHz	EC1381-6	12/09/2008
Controller	Mitsubishi CR-E116	EP1320-1	N/A
Robot	Mitsubishi RV-E2	EP1320-2	N/A
	Repeatability: ± 0.04 mm; Number of Axes: 6		
E-Field Probe	IXP-050	EC1356	01/14/2010
	Frequency Range: 800 MHz – 3000 MHz Probe outer diameter: 5.2 mm; Length: 350 mm; Distance between the probe tip and the dipole center: 2.7 mm		
Data Acquisition	SARA2	N/A	N/A
	Processor: Pentium 4; Clock speed: 1.5GHz; OS: Windows XP; I/O: two RS232; Software: SARA2 ver. 2.54 VPM		
Phantom	Upright Head Specific Anthropomorphic Mannequin (SAM) phantom, 2mm wall thickness box phantom	N/A	N/A
	The head and body phantom shell should be made of low-loss dielectric material with dielectric constant and loss tangent less than 5.0 and 0.05 respectively. The shell thickness for all regions coupled to the test device and its antenna should be within 2.0 ± 0.2 mm. The phantom should be filled with the required head or body equivalent tissue medium to a depth of 15.0 ± 0.5 cm. Body capacity: $152.5 \times 225.5 \times 200$ (W x L x D) mm^3 .		
Device holder	Material: clear Perspex	N/A	N/A
	Dielectric constant: less than 2.85 above 500MHz		
Simulated Tissue	Mixture	N/A	08/24/2010
	Please see section 3.2 for details		
RF Power Meter	Anritsu 2495A power sensor MA2411B	EC1411	10/09/2008
	Frequency Range: 300 MHz to 40 GHz, -20~+20dBm		
Vector Network Analyzer	HP 8753B, HP 85046A	EC1375	10/06/2009
	300k to 3GHz		
Signal Generator	R&S SMR27	EC1354	11/14/2008
	10M to 27GHz, <120dBuV		

Note: The above equipments are within the valid calibration period

3.1.1 Device test positions relative to the head

This practice specifies two handset test positions against the head phantom—the “cheek” position and the “tilt” position. These two test positions are defined in the following subclauses. The handset should be tested in both positions on left and right sides of the SAM phantom. If handset construction is such that the handset positioning procedures described in 3.1.1.1 and 3.1.1.2 to represent normal use conditions cannot be used, e.g., some asymmetric handsets, alternative alignment procedures should be adapted with all details provided in the test report. These alternative procedures should replicate intended use conditions as closely as possible according to the intent of the procedures described in this subclause.

3.1.1.1 Definition of the cheek position

The cheek position is established as follows:

- a) Ready the handset for talk operation, if necessary. For example, for handsets with a cover piece (flip cover), open the cover. If the handset can transmit with the cover closed, both configurations must be tested.
- b) Define two imaginary lines on the handset—the vertical centerline and the horizontal line. The vertical centerline passes through two points on the front side of the handset—the midpoint of the width w_t of the handset at the level of the acoustic output (point A in below figure), and the midpoint of the width w_b of the bottom of the handset (point B). The horizontal line is perpendicular to the vertical centerline and passes through the center of the acoustic output (see below left figure). The two lines intersect at point A. Note that for many handsets, point A coincides with the center of the acoustic output; however, the acoustic output may be located elsewhere on the horizontal line. Also note that the vertical centerline is not necessarily parallel to the front face of the handset (see right figure), especially for clamshell handsets, handsets with flip covers, and other irregularly-shaped handsets.
- c) Position the handset close to the surface of the phantom such that point A is on the (virtual) extension of the line passing through points RE and LE on the phantom (see the figure as next page), such that the plane defined by the vertical centerline and the horizontal line of the handset is approximately parallel to the sagittal plane of the phantom.
- d) Translate the handset towards the phantom along the line passing through RE and LE until handset point A touches the pinna at the ERP.

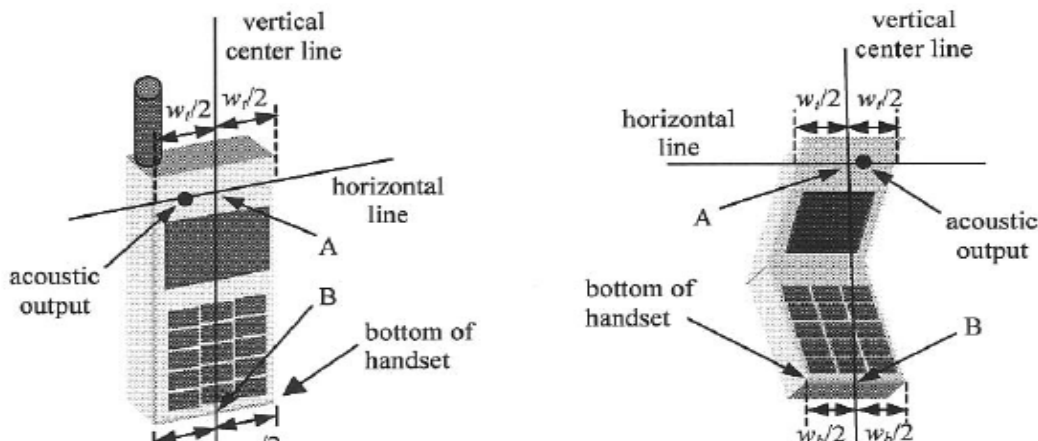

e) While maintaining the handset in this plane, rotate it around the LE-RE line until the vertical centerline is in the plane normal to the plane containing B-M and N-F lines, i.e., the Reference Plane.

f) Rotate the handset around the vertical centerline until the handset (horizontal line) is parallel to the N-F line.

g) While maintaining the vertical centerline in the Reference Plane, keeping point A on the line passing through RE and LE, and maintaining the handset contact with the pinna, rotate the handset about the N-F line until any point on the handset is in contact with a phantom point below the pinna on the cheek.

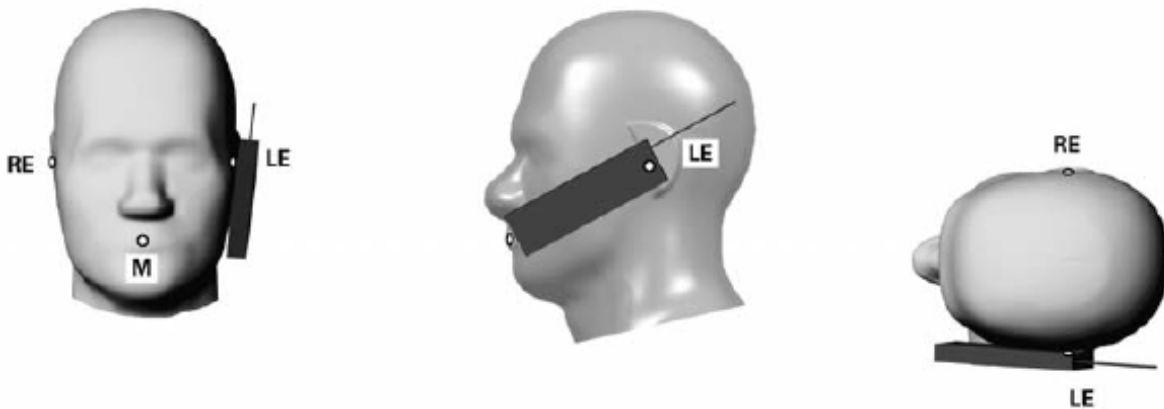

3.1.1.2 Definition of the tilt position

The tilt position is established as follows:

a) Repeat steps a) through g) of 3.1.1.1 to place the device in the cheek position.

b) While maintaining the orientation of the handset, move the handset away from the pinna along the line passing through RE and LE far enough to allow a rotation of the handset away from the cheek by 15°.

c) Rotate the handset around the horizontal line by 15°.

d) While maintaining the orientation of the handset, move the handset towards the phantom on the line passing through RE and LE until any part of the handset touches the ear. The tilt position is obtained when the contact point is on the pinna. See the figure as below. If contact occurs at any location other than the pinna, e.g., the antenna at the back of the phantom head, the angle of the handset should be reduced. In this case, the tilt position is obtained if any point on the handset is in contact with the pinna and a second point on the handset is in contact with the phantom, e.g., the antenna with the back of the head.

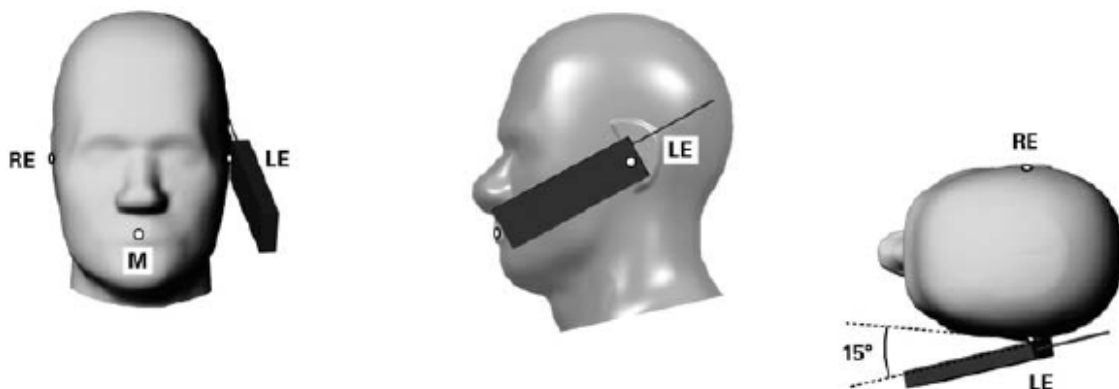

3.2 Tissue Simulating Liquid

The head and body tissue parameters should be used to test operating frequency band of transmitters. When a transmission band overlaps with one of the target frequencies, the tissue dielectric parameters of the tissue medium at the middle of a device transmission band should be within $\pm 5\%$ of the parameters specified at that target frequency.

3.2.1 Brain Tissue Simulating Liquid Recipes

Brain Ingredients Frequency (1900 MHz)	
Water	54.9%
Salt	0.18%
DGBE (Dilethylene Glycol Butyl Ether)	44.92%

The dielectric parameters were verified prior to assessment using the HP 85046A dielectric probe kit and the HP 8753B network Analyzer. The dielectric parameters were:

Freq. (MHz)	Temp. (°C)	ϵ_r / Relative Permittivity			σ / Conductivity (mho/m)			ρ ^{**} (kg/m ³)
		measured	Target*	Δ ($\pm 5\%$)	measured	Target*	Δ ($\pm 5\%$)	
1900	24	40.5416	40.0	1.3540	1.3668	1.40	-2.3714	1000

* Target values refer to IEEE 1528 2003 and FCC OET 65 Supplement C

** Worst-case assumption

4.0 Measurement Uncertainty

The uncertainty budget has been determined for the INDEXSAR SARA2 measurement system according to IEEE P1528 documents [3] and is given in the following table. The extended uncertainty (95% confidence level) was assessed to be 20.6 % for SAR measurement, and the extended uncertainty (95% confidence level) was assessed to be 20.2 % for system performance check.

Table 1 Exposure Assessment Uncertainty

a	b			c	d	e	f		g	h	i
Uncertainty Component	Sec.	Tol. (+/-)			Prob. Dist.	Divisor (descrip)	Divisor (value)	c1 (1g)	c1 (10g)	Standard Uncertainty (%) 1g	Standard Uncertainty (%) 10g
		(dB)		(%)							
Measurement System											
Probe Calibration	E2.1			2.5	N	1 or k	1	1	1	2.50	2.50
Axial Isotropy	E2.2	0.25	5.93	5.93	R	$\sqrt{3}$	1.73	0	0	0.00	0.00
Hemispherical Isotropy	E2.2	0.45	10.92	10.92	R	$\sqrt{3}$	1.73	1	1	6.30	6.30
Boundary effect	E2.3		4	4.00	R	$\sqrt{3}$	1.73	1	1	2.31	2.31
Linearity	E2.4	0.04	0.93	0.93	R	$\sqrt{3}$	1.73	1	1	0.53	0.53
System Detection Limits	E2.5		1	1.00	R	$\sqrt{3}$	1.73	1	1	0.58	0.58
Readout Electronics	E2.6		1	1.00	N	1 or k	1.00	1	1	1.00	1.00
Response time	E2.7		0	0.00	R	$\sqrt{3}$	1.73	1	1	0.00	0.00
Integration time	E2.8		1.4	1.40	R	$\sqrt{3}$	1.73	1	1	0.81	0.81
RF Ambient Conditions	E6.1		3	3.00	R	$\sqrt{3}$	1.73	1	1	1.73	1.73
Probe Positioner Mechanical Tolerance	E6.2		0.6	0.60	R	$\sqrt{3}$	1.73	1	1	0.35	0.35
Probe Position wrt. Phantom Shell	E6.3		3	3.00	R	$\sqrt{3}$	1.73	1	1	1.73	1.73
SAR Evaluation Algorithms	E5		8	8.00	R	$\sqrt{3}$	1.73	1	1	4.62	4.62
Test Sample Related											
Test Sample Positioning	E4.2		2	2.00	N	1	1.00	1	1	2.00	2.00
Device Holder Uncertainty	E4.1		2	2.00	N	1	1.00	1	1	2.00	2.00
Output Power Variation	6.6.2		5	5.00	R	$\sqrt{3}$	1.73	1	1	2.89	2.89
Phantom and Tissue Parameters											
Phantom Uncertainty (shape and thickness)	E3.1		4	4.00	R	$\sqrt{3}$	1.73	1	1	2.31	2.31
Liquid conductivity (Deviation from target)	E3.2		5	5.00	R	$\sqrt{3}$	1.73	0.64	0.43	1.85	1.24
Liquid conductivity (measurement uncert.)	E3.3		1.1	1.10	N	1	1.00	0.64	0.43	0.70	0.47
Liquid permittivity (Deviation from target)	E3.2		5	5.00	R	$\sqrt{3}$	1.73	0.6	0.49	1.73	1.41
Liquid permittivity (measurement uncert.)	E3.3		1.1	1.10	N	1	1.00	0.6	0.49	0.66	0.54
Combined standard uncertainty					RSS					10.5	10.3
Expanded uncertainty	(95% Confidence Level)				k=2					20.6	20.3

Table 2 System Check (Verification)

a	b	c		d	e	f	g	h	i		
Uncertainty Component	Sec.	Tol. (+/-)		Prob. Dist.	Divisor (descrip)	Divisor (value)	c1 (1g)	c1 (10g)	Standard Uncertainty (%) 1g	Standard Uncertainty (%) 10g	
		(dB)	(%)								
Measurement System											
Probe Calibration	E2.1		2.5	N	1 or k	1	1	1	2.50	2.50	
Axial Isotropy	E2.2	0.25	5.93	5.93	R	√3	1.73	0	0	0.00	0.00
Hemispherical Isotropy	E2.2	0.45	10.92	10.92	R	√3	1.73	1	1	6.30	6.30
Boundary effect	E2.3		4	4.00	R	√3	1.73	1	1	2.31	2.31
Linearity	E2.4	0.04	0.93	0.93	R	√3	1.73	1	1	0.53	0.53
System Detection Limits	E2.5		1	1.00	R	√3	1.73	1	1	0.58	0.58
Readout Electronics	E2.6		1	1.00	N	1 or k	1.00	1	1	1.00	1.00
Response time	E2.7		0	0.00	R	√3	1.73	1	1	0.00	0.00
Integration time	E2.8		1.4	1.40	R	√3	1.73	1	1	0.81	0.81
RF Ambient Conditions	E6.1		3	3.00	R	√3	1.73	1	1	1.73	1.73
Probe Positioner Mechanical Tolerance	E6.2		0.6	0.60	R	√3	1.73	1	1	0.35	0.35
Probe Position wrt. Phantom Shell	E6.3		3	3.00	R	√3	1.73	1	1	1.73	1.73
SAR Evaluation Algorithms	E5		8	8.00	R	√3	1.73	1	1	4.62	4.62
Dipole											
Dipole axis to liquid distance	8, E4.2		2	2.00	N	1	1.00	1	1	2.00	2.00
Input power and SAR drift measurement	8, 6.6.2		5	5.00	R	√3	1.73	1	1	2.89	2.89
Phantom and Tissue Parameters											
Phantom Uncertainty (thickness)	E3.1		4	4.00	R	√3	1.73	1	1	2.31	2.31
Liquid conductivity (Deviation from target)	E3.2		5	5.00	R	√3	1.73	0.64	0.43	1.85	1.24
Liquid conductivity (measurement uncert.)	E3.3		1.1	1.10	N	1	1.00	0.64	0.43	0.70	0.47
Liquid permittivity (Deviation from target)	E3.2		5	5.00	R	√3	1.73	0.6	0.49	1.73	1.41
Liquid permittivity (measurement uncert.)	E3.3		1.1	1.10	N	1	1.00	0.6	0.49	0.66	0.54
Combined standard uncertainty					RSS					10.3	10.1
Expanded uncertainty	(95% Confidence Level)				k=2					20.2	19.9

5.0 Test Results

The results on the following page(s) were obtained when the device was tested in the condition described in this report. Detailed measurement data and plots, which reveal information about the location of the maximum SAR with respect to the device, are reported in Appendix A.

Measurement Results

Trade Name:	Vtech	Model No.:	A1420
Serial No.:	Not Labeled	Test Engineer:	Fred Yu
TEST CONDITIONS			
Ambient Temperature	24 °C	Relative Humidity	50 %
Test Signal Source	Normal Mode	Signal Modulation	DECT
Conducted power Before SAR Test	See 1.4.3 of this report	Conducted power After SAR Test	See 1.4.3 of this report
Test Duration	23 min. each scan	Number of Battery Change	Fully Charged battery for every Scan

EUT Position					
Channel (MHz)	Operating Mode	Description	Degree or Distance	Measured SAR _{1g} (W/kg)	Plot Number
Middle	DECT	Right cheek	180°	0.011	1
Middle	DECT	Right tilt	180°	0.007	2
Middle	DECT	Left cheek	0°	0.008	3
Middle	DECT	Left tilt	0°	0.004	4

6.0 E-Field Probe and 1900 Dipole Antenna Calibration

Probe calibration factors and dipole antenna calibration are included in Appendix C.

7.0 WARNING LABEL INFORMATION - USA

See user manual.

8.0 REFERENCES

- [1] ANSI, *ANSI/IEEE C95.1-2005: IEEE Standard for Safety Levels with Respect to Human Exposure to Radio Frequency Electromagnetic Fields, 3kHz to 300 GHz*
- [2] Federal Communications Commission, "Evaluating Compliance with FCC Guidelines for Human Exposure to Radiofrequency Electromagnetic Fields", Supplement C (Edition 01-01) to OET Bulletin 65 (Edition 97-01)
- [3] IEEE Standards Coordinating Committee 34, "IEEE Recommended Practice for Determining the Peak Spatial-Average Specific Absorption Rate (SAR) in the Human Head from Wireless Communications Devices: Measurement Techniques", IEEE Std 1528TM-2003
- [4] Industry Canada, "Radio Frequency Exposure Compliance of Radiocommunication Apparatus (All Frequency Bands)", Radio Standards Specification RSS-102 Issue 4: March 2010.
- [5] IEC 62209-1 Human exposure to radio frequency fields from hand-held and body-mounted wireless communication devices – Human models, instrumentation, and procedures – Part 1: Procedure to determine the specific absorption rate (SAR) for hand-held devices used in close proximity to the ear (frequency range of 300MHz to 3GHz)



9.0 DOCUMENT HISTORY

Revision/ Job Number	Writer Initials	Date	Change
TS10080130-EME	S. Hsiao	Aug. 25, 2010	Original document

APPENDIX A - SAR Evaluation Data

Power drift is the measurement of power drift of the device over one complete SAR scan.

To assess the drift of the power of the device under test, a SAR measurement was made in the middle of the zoom scan volume at the start of the scan and a measurement at this point was then also made after the measurement scan. The difference between the two measurements should be greater or less than 5%.

Plot #1 (1/2)

Date / Time:	2010/8/24	Position:	Right Cheek
Filename:	A1420-RC.txt	Phantom:	HeadFT06.csv
Device Tested:	A1420-RC	Head Rotation:	180
Antenna:	Integral	Test Frequency:	1924.992 MHz
Shape File:	A1420-front.csv	Power Level:	20.39 dBm

Probe:	0136																
Cal File:	SN0136_1900_HEAD																
Cal Factors:	<table border="1"> <thead> <tr> <th></th> <th>X</th> <th>Y</th> <th>Z</th> </tr> </thead> <tbody> <tr> <td>Air</td> <td>459</td> <td>359</td> <td>382</td> </tr> <tr> <td>DCP</td> <td>20</td> <td>20</td> <td>20</td> </tr> <tr> <td>Lin</td> <td>.369</td> <td>.369</td> <td>.369</td> </tr> </tbody> </table>		X	Y	Z	Air	459	359	382	DCP	20	20	20	Lin	.369	.369	.369
		X	Y	Z													
	Air	459	359	382													
	DCP	20	20	20													
Lin	.369	.369	.369														
Batteries Replaced:	2010/08/24																

Liquid:	15.5 cm
Type:	1900 MHz Head
Conductivity:	1.3668
Relative Permittivity:	40.5146
Liquid Temp (deg C):	24
Ambient Temp (deg C):	24
Ambient RH (%):	50
Density (kg/m3):	1000
Software Version:	2.54

ZOOM SCAN RESULTS:

	Start Scan	End Scan
Spot SAR (W/kg):	0.004	0.004
Change during Scan (%):	-3.99	
Max E-field (V/m):	3.02	
Max SAR (W/kg)	1g	10g
	0.011	0.007

Location of Max (mm):	X	Y	Z
	77.4	22.0	-136.0

Plot #1 (2/2)

AREA SCAN:

Scan Extent:

	Min	Max	Steps
Y	-40.0	60.0	10.0
Z	-170.0	-90.0	8.0

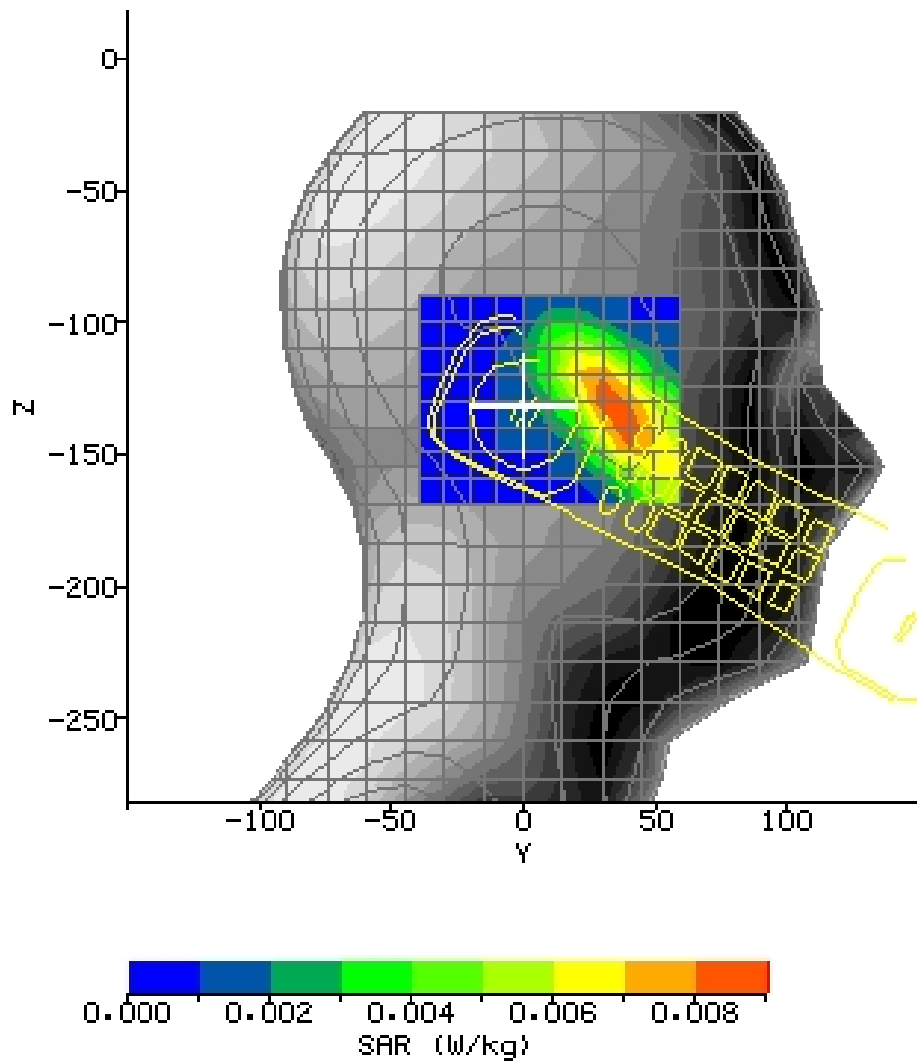

Plot #2 (1/2)

Date / Time:	2010/8/24	Position:	Right Tilt
Filename:	A1420-RT.txt	Phantom:	HeadFT06.csv
Device Tested:	A1420-RT	Head Rotation:	180
Antenna:	Integral	Test Frequency:	1924.992 MHz
Shape File:	A1420-front.csv	Power Level:	20.39 dBm

Probe:	0136																
Cal File:	SN0136_1900_HEAD																
Cal Factors:	<table border="1"> <thead> <tr> <th></th> <th>X</th> <th>Y</th> <th>Z</th> </tr> </thead> <tbody> <tr> <td>Air</td> <td>459</td> <td>359</td> <td>382</td> </tr> <tr> <td>DCP</td> <td>20</td> <td>20</td> <td>20</td> </tr> <tr> <td>Lin</td> <td>.369</td> <td>.369</td> <td>.369</td> </tr> </tbody> </table>		X	Y	Z	Air	459	359	382	DCP	20	20	20	Lin	.369	.369	.369
		X	Y	Z													
	Air	459	359	382													
	DCP	20	20	20													
Lin	.369	.369	.369														
Batteries Replaced:	2010/08/24																

Liquid:	15.5 cm
Type:	1900 MHz Head
Conductivity:	1.3668
Relative Permittivity:	40.5146
Liquid Temp (deg C):	24
Ambient Temp (deg C):	24
Ambient RH (%):	50
Density (kg/m3):	1000
Software Version:	2.54

ZOOM SCAN RESULTS:

Spot SAR (W/kg):	Start Scan	End Scan
	0.002	0.002

Change during Scan (%): -2.05

Max E-field (V/m): 2.43

Max SAR (W/kg)	1g	10g
	0.007	0.004

Location of Max (mm):

X	Y	Z
77.6	6.0	-121.0

Plot #2 (2/2)

AREA SCAN:

Scan Extent:

	Min	Max	Steps
Y	-40.0	60.0	10.0
Z	-170.0	-90.0	8.0

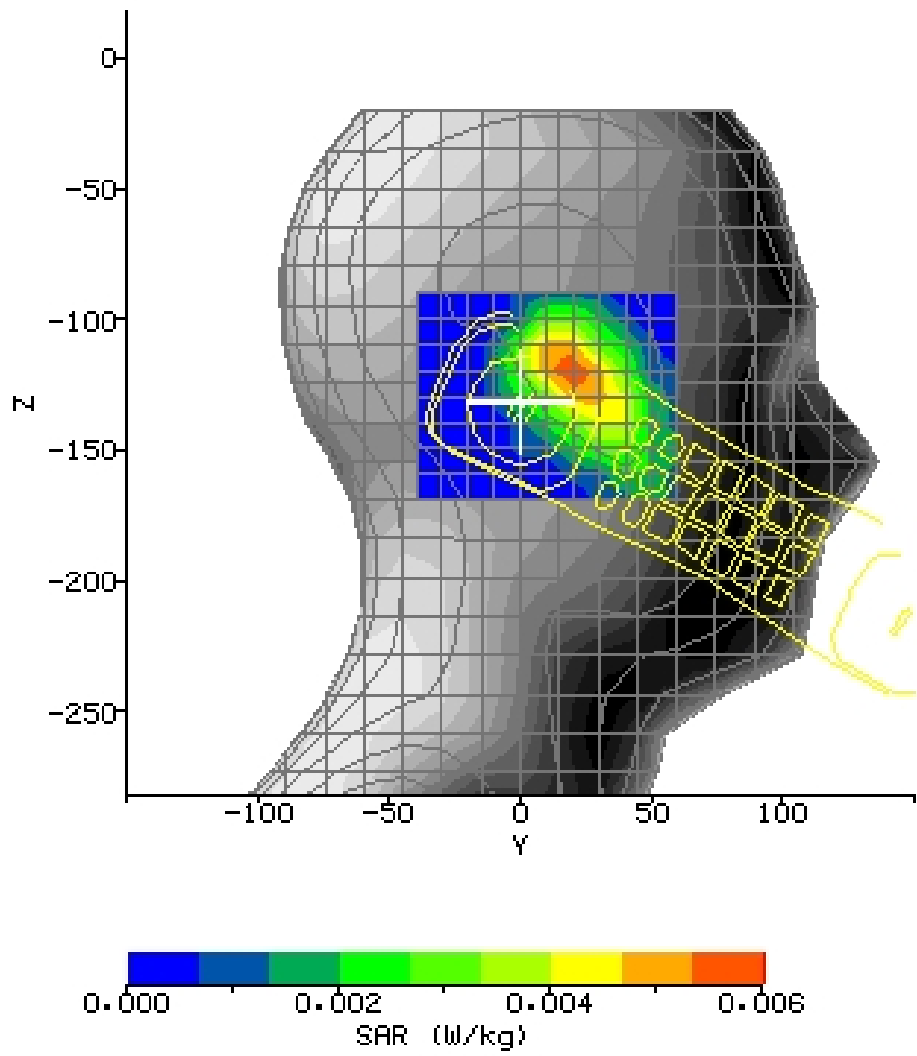

Plot #3 (1/2)

Date / Time:	2010/8/24	Position:	Left Cheek
Filename:	A1420-LC.txt	Phantom:	HeadFT06.csv
Device Tested:	A1420-LC	Head Rotation:	0
Antenna:	Integral	Test Frequency:	1924.992 MHz
Shape File:	A1420-front.csv	Power Level:	20.39 dBm

Probe:	0136																
Cal File:	SN0136_1900_HEAD																
Cal Factors:	<table border="1"> <thead> <tr> <th></th> <th>X</th> <th>Y</th> <th>Z</th> </tr> </thead> <tbody> <tr> <td>Air</td> <td>459</td> <td>359</td> <td>382</td> </tr> <tr> <td>DCP</td> <td>20</td> <td>20</td> <td>20</td> </tr> <tr> <td>Lin</td> <td>.369</td> <td>.369</td> <td>.369</td> </tr> </tbody> </table>		X	Y	Z	Air	459	359	382	DCP	20	20	20	Lin	.369	.369	.369
		X	Y	Z													
	Air	459	359	382													
	DCP	20	20	20													
Lin	.369	.369	.369														
Batteries Replaced:	2010/08/24																

Liquid:	15.5 cm
Type:	1900 MHz Head
Conductivity:	1.3668
Relative Permittivity:	40.5146
Liquid Temp (deg C):	24
Ambient Temp (deg C):	24
Ambient RH (%):	50
Density (kg/m3):	1000
Software Version:	2.54

ZOOM SCAN RESULTS:

Spot SAR (W/kg):	Start Scan	End Scan
	0.003	0.003

Change during Scan (%): -1.52

Max E-field (V/m): 2.47

Max SAR (W/kg)	1g	10g
	0.008	0.006

Location of Max (mm):	X	Y	Z
	75.2	-51.0	-150.1

Plot #3 (2/2)

AREA SCAN:

Scan Extent:

	Min	Max	Steps
Y	-60.0	40.0	10.0
Z	-170.0	-90.0	8.0

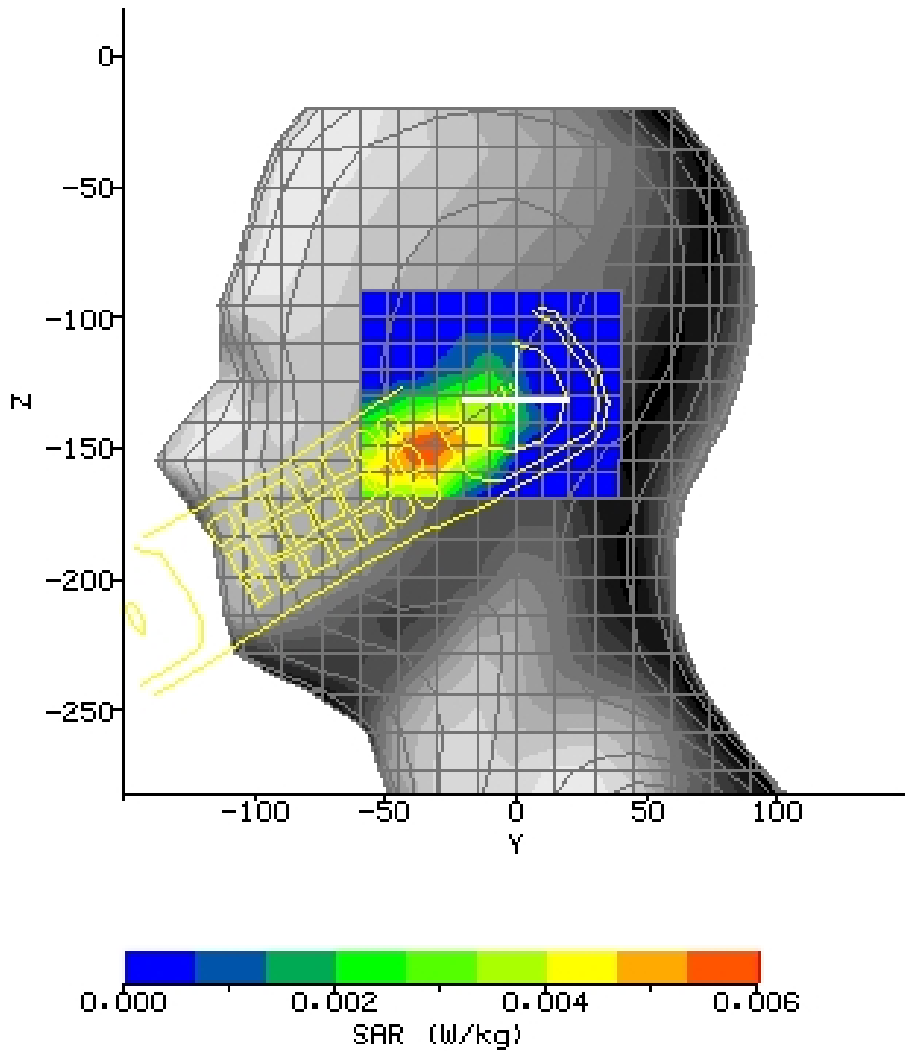

Plot #4 (1/2)

Date / Time:	2010/8/24	Position:	Left Tilt
Filename:	A1420-LT.txt	Phantom:	HeadFT06.csv
Device Tested:	A1420-LT	Head Rotation:	0
Antenna:	Integral	Test Frequency:	1924.992 MHz
Shape File:	A1420-front.csv	Power Level:	20.39 dBm

Probe:	0136																
Cal File:	SN0136_1900_HEAD																
Cal Factors:	<table border="1"> <thead> <tr> <th></th> <th>X</th> <th>Y</th> <th>Z</th> </tr> </thead> <tbody> <tr> <td>Air</td> <td>459</td> <td>359</td> <td>382</td> </tr> <tr> <td>DCP</td> <td>20</td> <td>20</td> <td>20</td> </tr> <tr> <td>Lin</td> <td>.369</td> <td>.369</td> <td>.369</td> </tr> </tbody> </table>		X	Y	Z	Air	459	359	382	DCP	20	20	20	Lin	.369	.369	.369
		X	Y	Z													
	Air	459	359	382													
	DCP	20	20	20													
Lin	.369	.369	.369														
Batteries Replaced:	2010/08/24																

Liquid:	15.5 cm
Type:	1900 MHz Head
Conductivity:	1.3668
Relative Permittivity:	40.5146
Liquid Temp (deg C):	24
Ambient Temp (deg C):	24
Ambient RH (%):	50
Density (kg/m3):	1000
Software Version:	2.54

ZOOM SCAN RESULTS:

Spot SAR (W/kg):	Start Scan	End Scan
	0.001	0.001

Change during Scan (%): -3.71

Max E-field (V/m): 1.73

Max SAR (W/kg)	1g	10g
	0.004	0.002

Location of Max (mm):	X	Y	Z
	76.8	-33.0	-145.9

Plot #4 (2/2)

AREA SCAN:

Scan Extent:

	Min	Max	Steps
Y	-60.0	40.0	10.0
Z	-170.0	-90.0	8.0

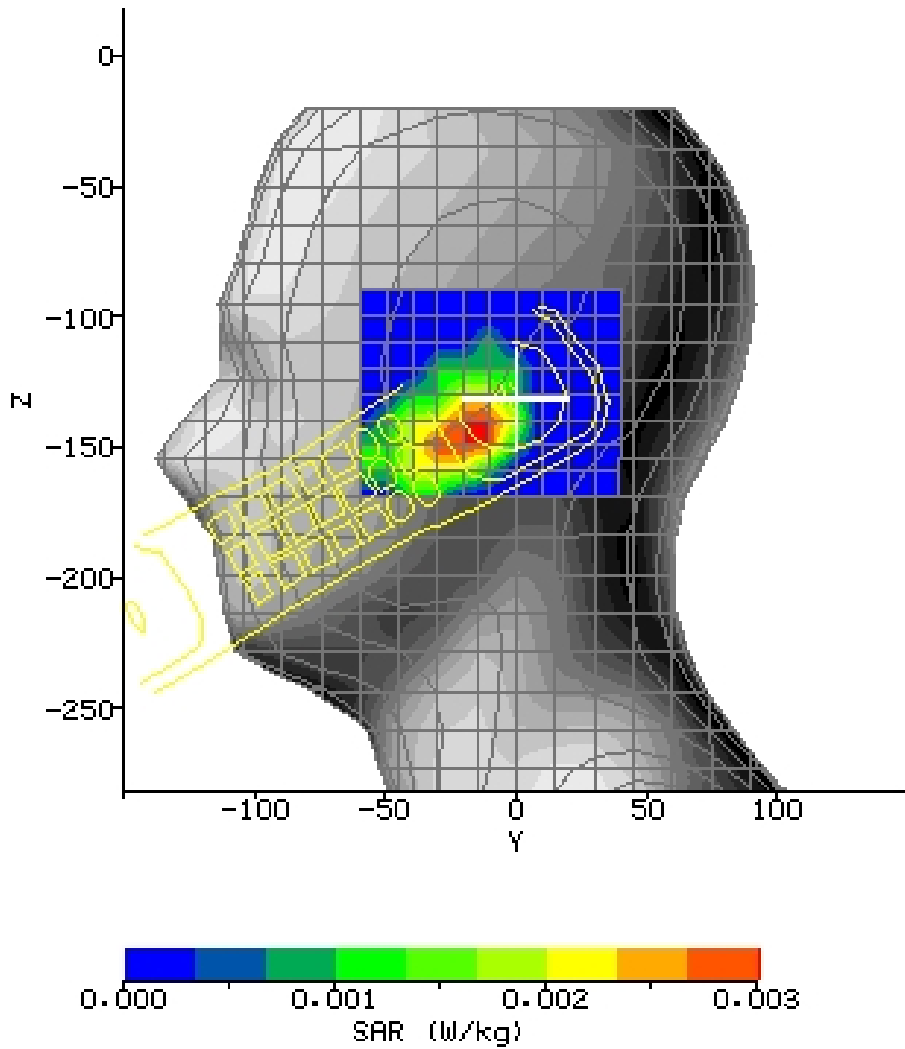

APPENDIX B - Photographs

Exterior photo 1
Handset



Exterior photo 2
Handset



Exterior photo 3
Accessories - Base unit



Exterior photo 4
Accessories - Base unit



Exterior photo 5
Accessories - Adapter



Exterior photo 6
Accessories – Adapter label



Exterior photo 7
Accessories- Battery



Exterior photo 8
Accessories- Battery





APPENDIX C - E-Field Probe and 1900MHz Dipole Antenna Calibration Data



IMMERSIBLE SAR PROBE

CALIBRATION REPORT

Part Number: IXP – 050

S/N 0136

January 2010

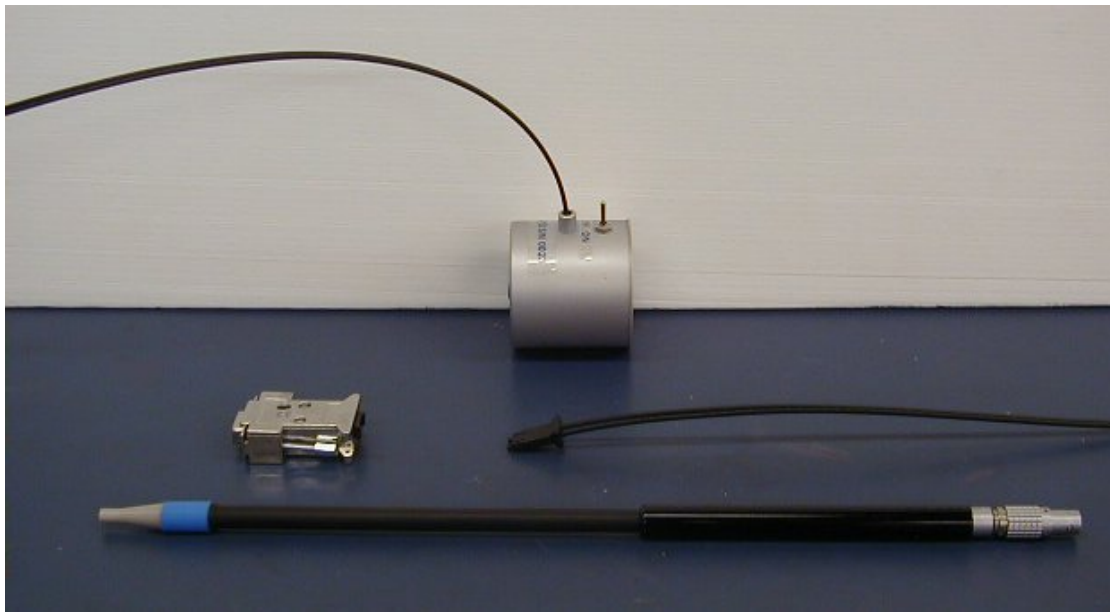

**Indexsar Limited
Oakfield House
Cudworth Lane
Newdigate
Surrey RH5 5BG**

Tel: +44 (0) 1306 632 870

Fax: +44 (0) 1306 631 834

e-mail: enquiries@indexsar.com



Indexsar Limited
Oakfield House
Cudworth Lane
Newdigate
Surrey RH5 5BG
Tel: +44 (0) 1306 632 870
Fax: +44 (0) 1306 631 834
e-mail: enquiries@indexsar.com

Calibration Certificate 1001/0136
Date of Issue: 14th January 2010
Immersible SAR Probe

Type:	IXP-050
Manufacturer:	IndexSAR, UK
Serial Number:	0136
Place of Calibration:	IndexSAR, UK
Date of Receipt of Probe:	26 th February 2009
Calibration Dates:	12 th November — 24 th December 2009
Customer:	ITS

IndexSAR Ltd hereby declares that the IXP-050 Probe named above has been calibrated for conformity to the IEEE 1528 and BSEN 62209-1 standards using the methods described in this calibration document. Where applicable, the standards used in the calibration process are traceable to the UK's National Physical Laboratory.

Calibrated by:

Technical Manager

Approved by:

Director

Please keep this certificate with the calibration document. When the probe is sent for a calibration check, please include the calibration document.

INTRODUCTION

This Report presents measured calibration data for a particular Indexsar SAR probe (S/N 0136) only and describes the procedures used for characterisation and calibration.

Indexsar probes are characterised using procedures that, where applicable, follow the recommendations of BSEN 62209-1 [Ref 1] & IEEE 1528 [Ref 2] standards. The procedures incorporate techniques for probe linearisation, isotropy assessment and determination of liquid factors (conversion factors). Calibrations are determined by comparing probe readings with analytical computations in canonical test geometries (waveguides) using normalised power inputs.

Each step of the calibration procedure and the equipment used is described in the sections below.

CALIBRATION PROCEDURE

1. Objectives

The calibration process comprises four stages

- 1) Determination of the channel sensitivity factors which optimise the probe's overall rotational isotropy in 900MHz brain fluid
- 2) Determination of the channel sensitivity factors and angular offset of the X channel which together optimise the probe's spherical isotropy in 900MHz brain fluid
- 3) Numerical combination of the two sets of channel sensitivity factors to give both acceptable rotational isotropy and acceptable spherical isotropy values
- 4) At each frequency of interest, application of these channel sensitivity factors to model the exponential decay of SAR in a waveguide fluid cell, and hence derive the liquid conversion factors at that frequency

2. Probe output

The probe channel output signals are linearised in the manner set out in Refs [1] and [2]. The following equation is utilized for each channel:

$$U_{lin} = U_{op} + U_{op}^2 / DCP \quad (1)$$

where U_{lin} is the linearised signal, U_{op} is the raw output signal in mV and DCP is the diode compression potential in similar voltage units.

DCP is determined from fitting equation (1) to measurements of U_{lin} versus source feed power over the full dynamic range of the probe. The DCP is a characteristic of the Schottky diodes used as the sensors. For the IXP-050 probes with CW signals the DCP values are typically 100mV (or 20 in the voltage units used by Indexsar software, which are $V*200$).

In turn, measurements of E-field are determined using the following equation (where output voltages are also in units of $V*200$):

$$E_{liq}^2 \text{ (V/m)} = U_{linx} * Air Factor_x * Liq Factor_x + U_{liny} * Air Factor_y * Liq Factor_y + U_{linz} * Air Factor_z * Liq Factor_z \quad (3)$$

Here, "Air Factor" represents each channel's sensitivity, while "Liq Factor" represents the enhancement in signal level when the probe is immersed in tissue-simulant liquids at each frequency of interest.

3. Selecting channel sensitivity factors to optimise isotropic response

After manufacture, the first stage of the calibration process is to balance the three channels' Air Factor values, thereby optimising the probe's overall axial response ("rotational isotropy").

To do this, a 900MHz waveguide containing head-fluid simulant is selected. Like all waveguides used during probe calibration, this particular waveguide contains two distinct sections: an air-filled launcher section, and a liquid cell section, separated by a dielectric matching window designed to minimise reflections at the air-liquid interface.

The waveguide stands in an upright position and the liquid cell section is filled with 900MHz brain fluid to within 10 mm of the open end. The depth of liquid ensures there is negligible radiation from the waveguide open top and that the probe calibration is not influenced by reflections from nearby objects.

During the measurement, a TE_{01} mode is launched into the waveguide by means of an N-type-to-waveguide adapter. The probe is then lowered vertically into the liquid until the tip is exactly 10mm above the centre of the dielectric window. This particular separation ensures that the probe is operating in a part of the waveguide where boundary corrections are not necessary.

Care must also be taken that the probe tip is centred while rotating.

The exact power applied to the input of the waveguide during this stage of the probe calibration is immaterial since only relative values are of interest while the probe rotates. However, the power must be sufficiently above the noise floor and free from drift.

The dedicated Indexsar calibration software rotates the probe in 10 degree steps about its axis, and at each position, an Indexsar 'Fast' amplifier samples the probe channels 500 times per second for 0.4 s. The raw $U_{o/p}$ data from each sample are packed into 10 bytes and transmitted back to the PC controller via an optical cable. U_{linx} , U_{liny} and U_{linz} are derived from the raw $U_{o/p}$ values and written to an Excel template.

Once data have been collected from a full probe rotation, the Air Factors are adjusted using a special Excel Solver routine to equalise the output from each channel and hence minimise the rotational isotropy. This automated approach to optimisation removes the effect of human bias.

Figure 5 represents the output from each diode sensor as a function of probe rotation angle.

4. Measurement of Spherical Isotropy

The setup for measuring the probe's spherical isotropy is shown in Figure 2.

A box phantom containing 900MHz head fluid is irradiated by a vertically-polarised, tuned dipole, mounted to the side of the phantom on the robot's seventh axis. During calibration, the spherical response is generated by rotating the probe about its axis in 20 degree steps and changing the dipole polarisation in 10 degree steps.

By using the VPM technique discussed below, an allowance can also be made for the effect of E-field gradient across the probe's spatial extent. This permits values for the probe's

effective tip radius and X-channel angular offset to be modelled until the overall spherical

isotropy figure is optimised.

The dipole is connected to a signal generator and amplifier via a directional coupler and power meter. As with the determination of rotational isotropy, the absolute power level is not important as long as it is stable.

The probe is positioned within the fluid so that its sensors are at the same vertical height as the centre of the source dipole. The line joining probe to dipole should be perpendicular to the phantom wall, while the horizontal separation between the two should be small enough for VPM corrections to be applicable, without encroaching near the boundary layer of the phantom wall. VPM corrections require a knowledge of the fluid skin depth. This is measured during the calibration by recording the E-field strength while systematically moving the probe away from the dipole in 2mm steps over a 20mm range.

The directionality of the orthogonally-arranged sensors can be checked by analysing the data using dedicated Indexsar software, which displays the data in 3D format, a representative image of which is shown in Figure 3. The left-hand side of this diagram shows the individual channel outputs after linearisation (see above). The program uses these data to balance the channel outputs and then applies an optimisation process, which makes fine adjustments to the channel factors for optimum isotropic response.

5. Determination of Conversion (“Liquid”) Factors at each frequency of interest

A lookup table of conversion factors for a probe allows a SAR value to be derived at the measured frequencies, and for either brain or body fluid-simulant.

The method by which the conversion factors are assessed is based on the comparison between measured and analytical rates of decay of SAR with height above a dielectric window. This way, not only can the conversion factors for that frequency/fluid combination be determined, but an allowance can also be made for the scale and range of boundary layer effects.

The theoretical relationship between the SAR at the cross-sectional centre of the lossy waveguide as a function of the longitudinal distance (z) from the dielectric separator is given by Equation 4:

$$SAR(z) = \frac{4(P_f - P_b)}{\rho ab \delta} e^{-2z/\delta} \quad (4)$$

Here, the density ρ is conventionally assumed to be 1000 kg/m³, ab is the cross-sectional area of the waveguide, and P_f and P_b are the forward and reflected power inside the lossless section of the waveguide, respectively. The penetration depth δ (which is the reciprocal of the waveguide-mode attenuation coefficient) is a property of the lossy liquid and is given by Equation (5).

$$\delta = \left[\text{Re} \left\{ \sqrt{(\pi/a)^2 + j\omega\mu_o(\sigma + j\omega\epsilon_o\epsilon_r)} \right\} \right]^{-1} \quad (5)$$

where σ is the conductivity of the tissue-simulant liquid in S/m, ϵ_r is its relative permittivity, and ω is the radial frequency (rad/s). Values for σ and ϵ_r are obtained prior to each

waveguide test using an Indexsar DiLine measurement kit, which uses the TEM method as recommended in [2]. σ and ϵ_r are both temperature- and fluid-dependent, so are best measured using a sample of the tissue-simulant fluid immediately prior to the actual calibration.

Wherever possible, all DiLine and calibration measurements should be made in the open laboratory at $22 \pm 2.0^\circ\text{C}$; if this is not possible, the values of σ and ϵ_r should reflect the actual temperature. Values employed for calibration are listed in the tables below.

By ensuring the liquid height in the waveguide is at least three penetration depths, reflections at the upper surface of the liquid are negligible. The power absorbed in the liquid is therefore determined solely from the waveguide forward and reflected power.

Different waveguides are used for 835/900MHz, 1800/1900MHz, 2100/2450/2600MHz and 5200/5800MHz measurements. Table A.1 of [1] can be used for designing calibration waveguides with a return loss greater than 20 dB at the most important frequencies used for personal wireless communications, and better than 15dB for frequencies greater than 5GHz. Values for the penetration depth for these specific fixtures and tissue-simulating mixtures are also listed in Table A.1.

According to [1], this calibration technique provides excellent accuracy, with standard uncertainty of less than 3.6% depending on the frequency and medium. The calibration itself is reduced to power measurements traceable to a standard calibration procedure. The practical limitation to the frequency band of 800 to 5800 MHz because of the waveguide size is not severe in the context of compliance testing.

During calibration, the probe is lowered carefully until it is just touching the cross-sectional centre of the dielectric window. 200 samples are then taken and written to an Excel template file before moving the probe vertically upwards. This cycle is repeated 150 times. The vertical separation between readings is determined from practical considerations of the expected SAR decay rate, and range from 0.2mm steps at low frequency, through 0.1mm at 2450MHz, down to 0.05mm at 5GHz.

Once the data collection is complete, a Solver routine is run which optimises the measured-theoretical fit by varying the conversion factor, and the boundary correction size and range.

For 450 MHz calibrations, a slightly different technique must be used — the equatorial response of the probe-under-test is compared with the equivalent response of a probe whose 450MHz characteristics have already been determined by NPL. The conversion factor of the probe-under-test can then be deduced.

VPM (Virtual Probe Miniaturisation)

SAR probes with 3 diode-sensors in an orthogonal arrangement are designed to display an isotropic response when exposed to a uniform field. However, the probes are ordinarily used for measurements in non-uniform fields and isotropy is not assured when the field gradients are significant compared to the dimensions of the tip containing the three orthogonally-arranged dipole sensors.

It becomes increasingly important to assess the effects of field gradients on SAR probe readings when higher frequencies are being used. For Indexsar IXP-050 probes, which are of 5mm tip diameter, field gradient effects are minor at GSM frequencies, but are major

above 5GHz. Smaller probes are less affected by field gradients and so probes, which are significantly less than 5mm diameter, would be better for applications above 5GHz.

The IndexSAR report IXS0223 describes theoretical and experimental studies to evaluate the issues associated with the use of probes at arbitrary angles to surfaces and field directions. Based upon these studies, the procedures and uncertainty analyses referred to in P1528 are addressed for the full range of probe presentation angles.

In addition, generalized procedures for correcting for the finite size of immersible SAR probes are developed. Use of these procedures enables application of schemes for virtual probe miniaturization (VPM) – allowing probes of a specific size to be used where physically-smaller probes would otherwise be required.

Given the typical dimensions of 3-channel SAR probes presently available, use of the VPM technique extends the satisfactory measurement range to higher frequencies.

CALIBRATION FACTORS MEASURED FOR PROBE S/N 0136

The probe was calibrated at 450, 835, 900, 1800, 1900, 2100, 2450 and 2600 MHz in liquid samples representing brain and body liquid at these frequencies.

The calibration was for CW signals only, and the axis of the probe was parallel to the direction of propagation of the incident field i.e. end-on to the incident radiation. The axial isotropy of the probe was measured by rotating the probe about its axis in 10 degree steps through 360 degrees in this orientation.

The reference point for the calibration is in the centre of the probe's cross-section at a distance of 2.7 mm from the probe tip in the direction of the probe amplifier. A value of 2.7 mm should be used for the tip to sensor offset distance in the software. The distance of 2.7mm for assembled probes has been confirmed by taking X-ray images of the probe tips (see Figure 9).

It is important that the diode compression point and air factors used in the software are the same as those quoted in the results tables, as these are used to convert the diode output voltages to a SAR value.

CALIBRATION EQUIPMENT

The table on page 20 indicates the calibration status of all test equipment used during probe calibration.

MEASUREMENT UNCERTAINTIES

A complete measurement uncertainty analysis for the SARA2 measurement system has been published in Reference [3]. Table 10 from that document is re-created below, and lists the uncertainty factors associated just with the calibration of probes.

Source of uncertainty	Uncertainty value \pm %	Probability distribution	Divisor	c_i	Standard uncertainty u_i \pm %	v_i or v_{eff}
Incident or forward power	5.743	N	1.00	1	5.743	∞
Reflected power	5.773	N	1.00	1	5.773	∞
Liquid conductivity	1.120	N	1.00	1	1.120	∞
Liquid permittivity	1.085	N	1.00	1	1.085	∞
Field homogeneity	0.002	R	1.73	1	0.001	∞
Probe positioning: +/- 0.05mm	0.55	R	1.73	1	0.318	
Influence on Probe pos: 11%/mm						
Field probe linearity	4.7	R	1.73	1	2.714	∞
Combined standard uncertainty		RSS			8.729	

At the 95% confidence level, therefore, the expanded uncertainty is 17.1%

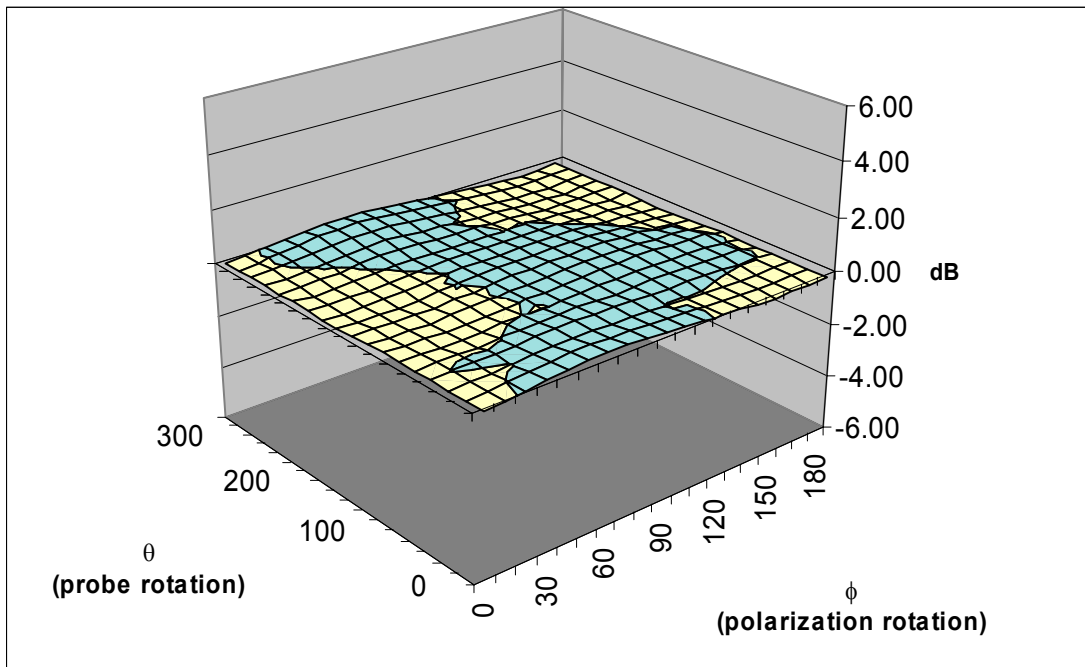

Surface Isotropy diagram of IXP-050 Probe S/N 0136 at 900MHz after VPM (rotational isotropy axial +/-0.09dB, spherical isotropy +/-0.28dB)

Probe tip radius 1.25
 X Ch. Angle to red dot -8.1

Frequency	Head		Body	
	Bdy. Corr. – f(0)	Bdy. Corr. – d(mm)	Bdy. Corr. – f(0)	Bdy. Corr. – d(mm)
450	0.0	1.0	0.0	1.0
835	0.9	1.4	1.4	1.2
900	1.2	1.3	1.2	1.3
1800	0.9	1.5	0.9	1.5
1900	0.9	1.6	1.0	1.5
2100	0.9	1.4	0.8	1.8
2450	0.8	1.6	0.8	1.8
2600	0.9	1.5	0.7	1.8

SUMMARY OF CALIBRATION FACTORS FOR PROBE IXP-050 S/N 0136

Spherical isotropy measured at 900MHz	0.28	(+/-) dB
---------------------------------------	------	----------

	X	Y	Z	
Air Factors	459	359	382	$(V*200)^2/mV$
CW DCPs	20	20	20	V*200

Freq (MHz)	Axial Isotropy		SAR ConvF		Notes
	(+/- dB)		(liq/air)		
	Head	Body	Head	Body	
450	-	-	0.336	0.316	3
835	-	-	0.279	0.295	1,2
900	0.09	-	0.289	0.303	1,2
1800	-	-	0.352	0.388	1,2
1900	-	-	0.369	0.413	1,2
2100	-	-	0.374	0.427	1,2
2450	-	-	0.406	0.459	1,2
2600	-	-	0.437	0.490	1,2

Notes	
1)	Calibrations done at 22°C +/-2°C
2)	Waveguide calibration
3)	Transfer calibration

PROBE SPECIFICATIONS

Indexsar probe 0136, along with its calibration, is compared with BSEN 62209-1 and IEEE standards recommendations (Refs [1] and [2]) in the Tables below. A listing of relevant specifications is contained in the tables below:

Dimensions	S/N 0136	BSEN [1]	IEEE [2]
Overall length (mm)	350		
Tip length (mm)	10		
Body diameter (mm)	12		
Tip diameter (mm)	5.2	8	8
Distance from probe tip to dipole centers (mm)	2.7		

Dynamic range	S/N 0136	BSEN [1]	IEEE [2]
Minimum (W/kg)	0.01	<0.02	0.01
Maximum (W/kg) N.B. only measured to > 100 W/kg on representative probes	>100	>100	100

Isotropy (measured at 900MHz)	S/N 0136	BSEN [1]	IEEE [2]
Axial rotation with probe normal to source (+/- dB)	0.09	0.5	0.25
Spherical isotropy covering all orientations to source (+/- dB)	0.28	1.0	0.50

Construction	Each probe contains three orthogonal dipole sensors arranged on a triangular prism core, protected against static charges by built-in shielding, and covered at the tip by PEEK cylindrical enclosure material. No adhesives are used in the immersed section. Outer case materials are PEEK and heat-shrink sleeving.
Chemical resistance	Tested to be resistant to TWEEN20 and sugar/salt-based simulant liquids but probes should be removed, cleaned and dried when not in use. NOT recommended for use with glycol or soluble oil-based liquids.

REFERENCES

- [1] BSEN 62209-1:2006. Human exposure to radio frequency fields from hand-held and body-mounted wireless communication devices — Human models, instrumentation, and procedures — Part 1: Procedure to determine the specific absorption rate (SAR) for hand-held devices used in close proximity to the ear (frequency range of 300 MHz to 3 GHz)
- [2] IEEE 1528, 2003 Recommended Practice for Determining the Peak Spatial-Average Specific Absorption Rate (SAR) in the Human Head from Wireless Communications Devices: Measurement Techniques
- [3] Indexsar Report IXS-0300, October 2007. Measurement uncertainties for the SARA2 system assessed against the recommendations of BS EN 62209-1:2006

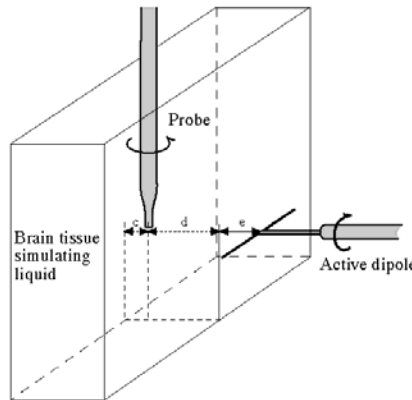
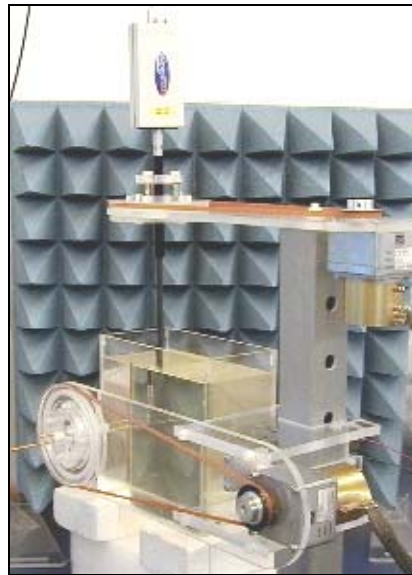

Figure 1. Spherical isotropy jig showing probe, dipole and box filled with simulated brain liquid (see Ref [2], Section A.5.2.1)

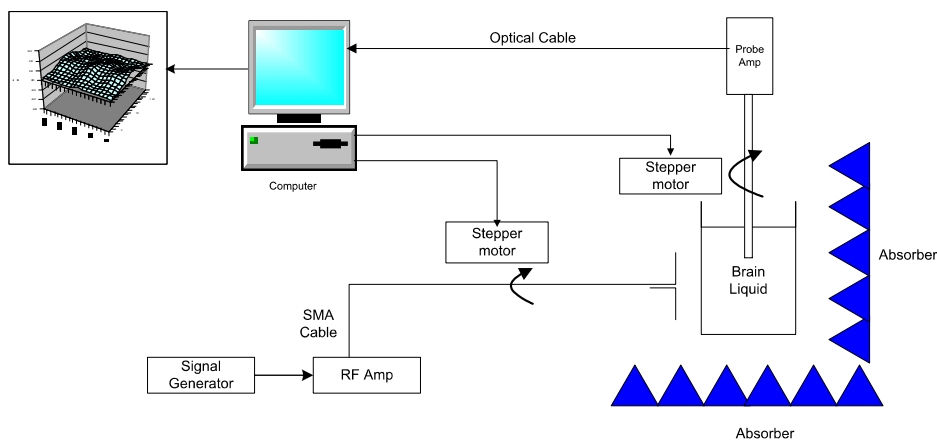

Figure 2. Schematic diagram of the test geometry used for isotropy determination

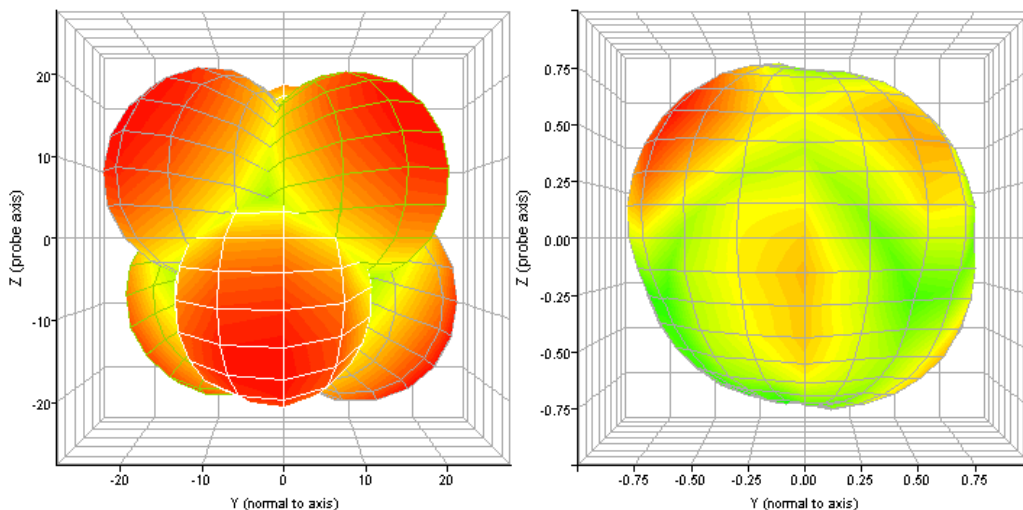

Figure 3. Graphical representation of probe 0136's response to fields applied from each direction. The diagram on the left shows the individual response characteristics of each of the three channels and the diagram on the right shows the resulting probe sensitivity in each direction. The colour range in the figure images the lowest values as blue and the maximum values as red. For probe S/N 0136, this range is (+/-) 0.28.

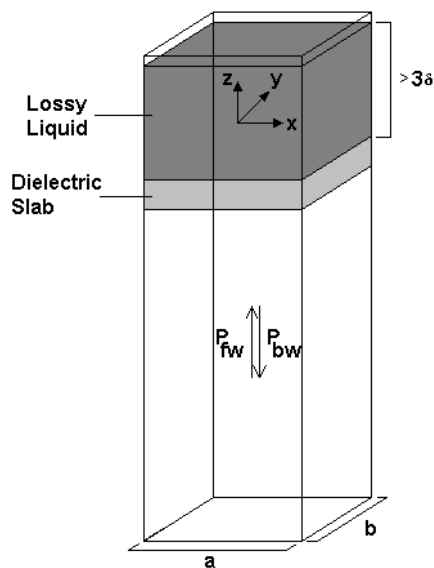

Figure 4. Geometry used for waveguide calibration (after Ref [2]. Section A.3.2.2)

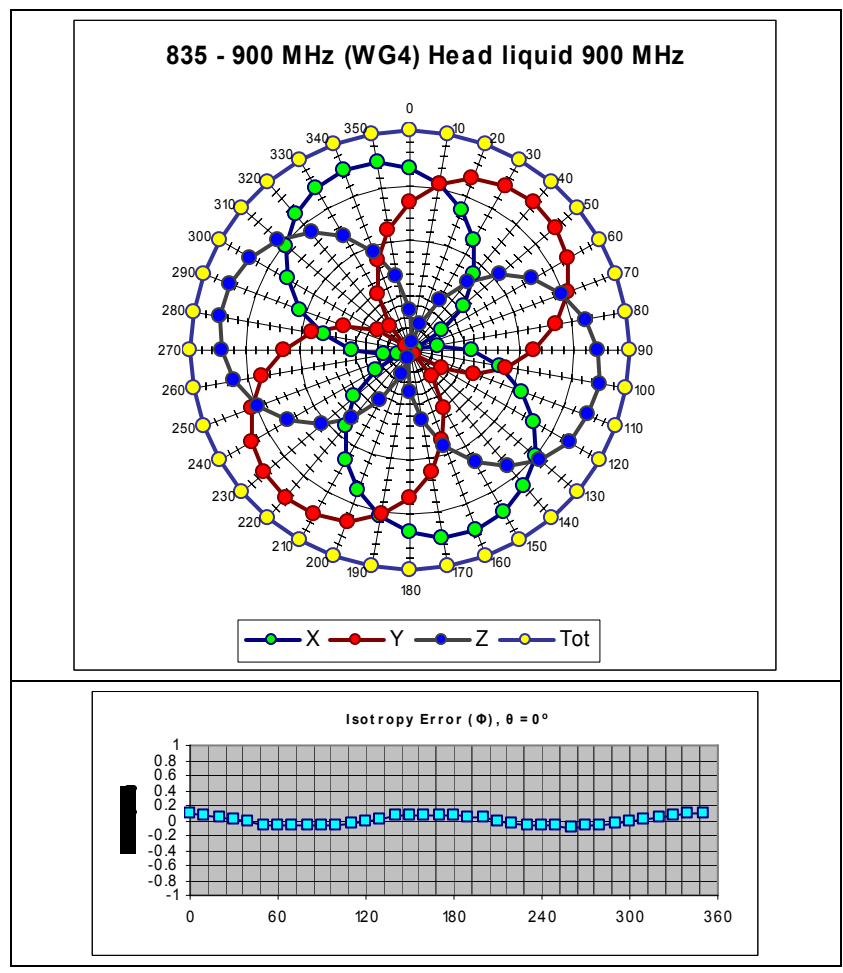

Figure 5. The rotational isotropy of probe S/N 0136 obtained by rotating the probe in a liquid-filled waveguide at 900 MHz.

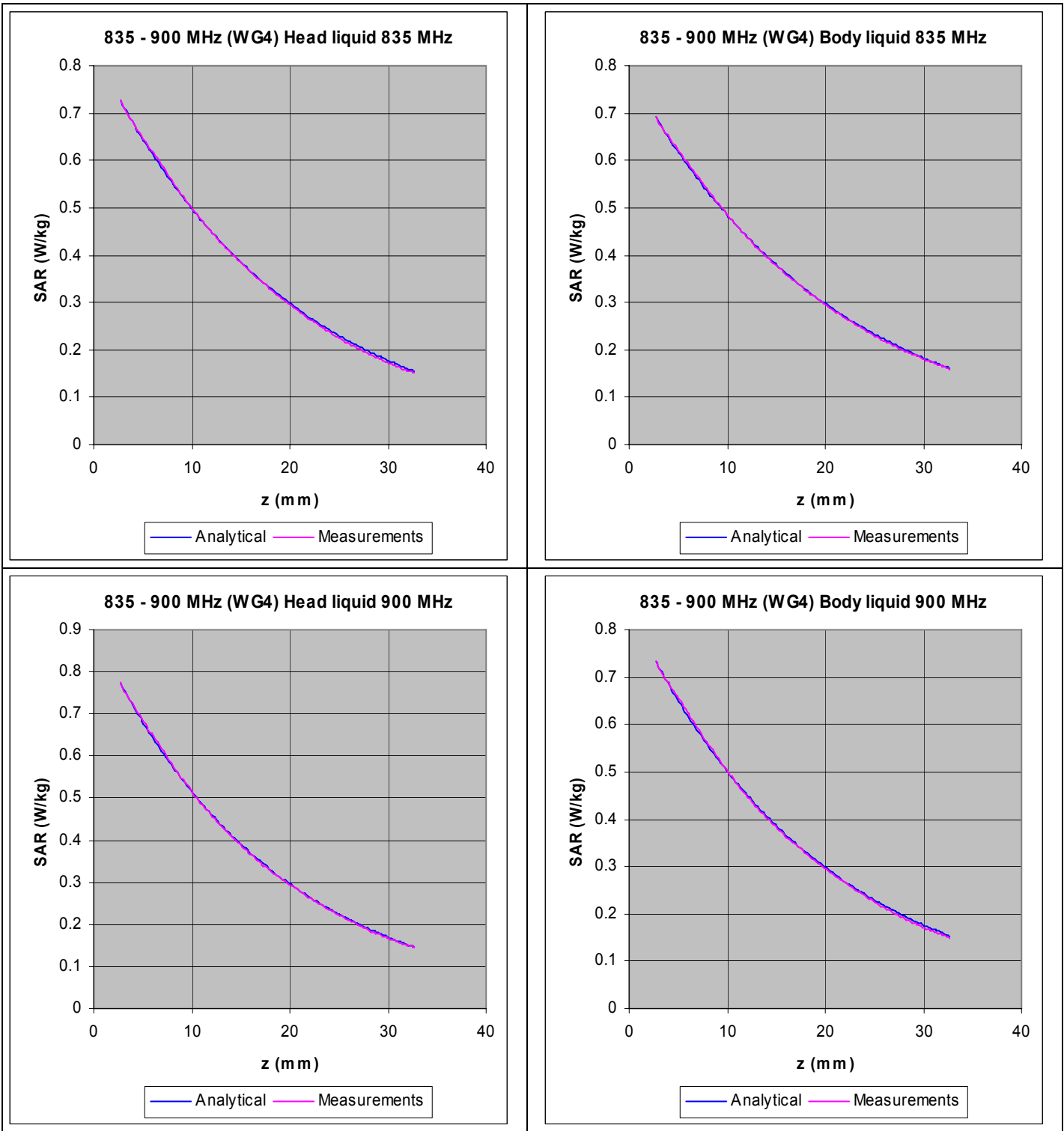
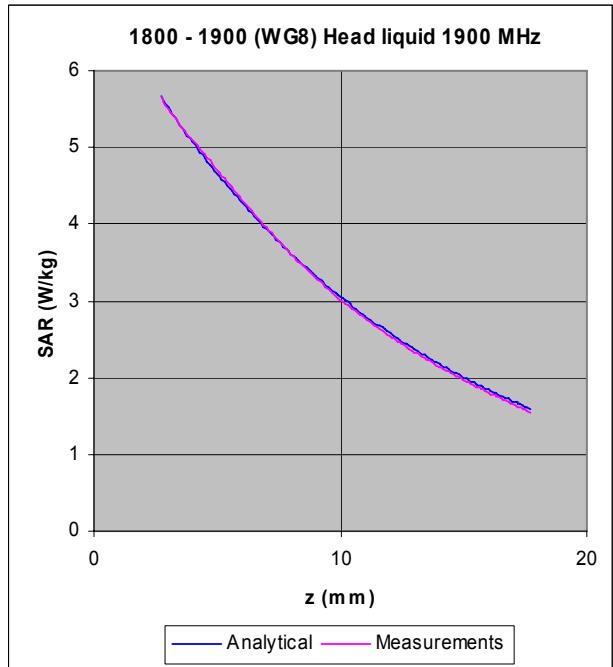
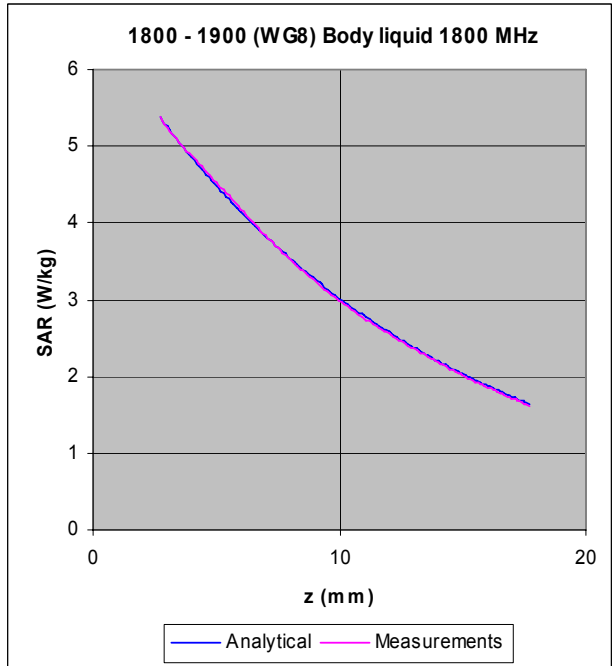
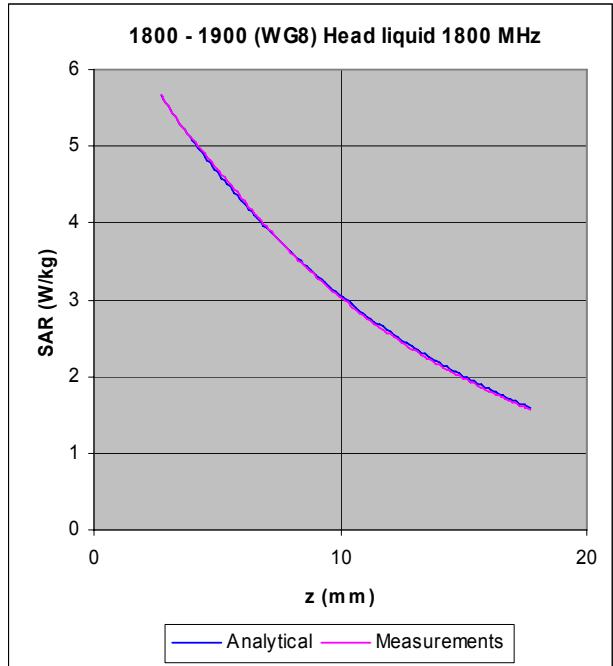
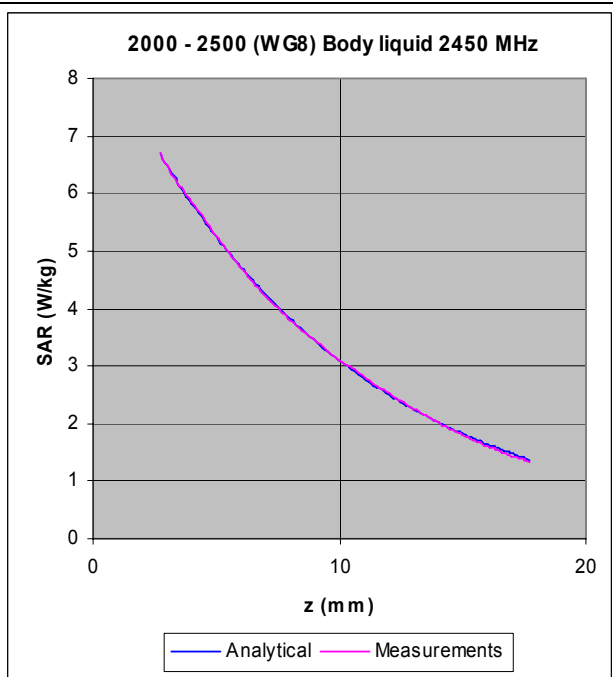
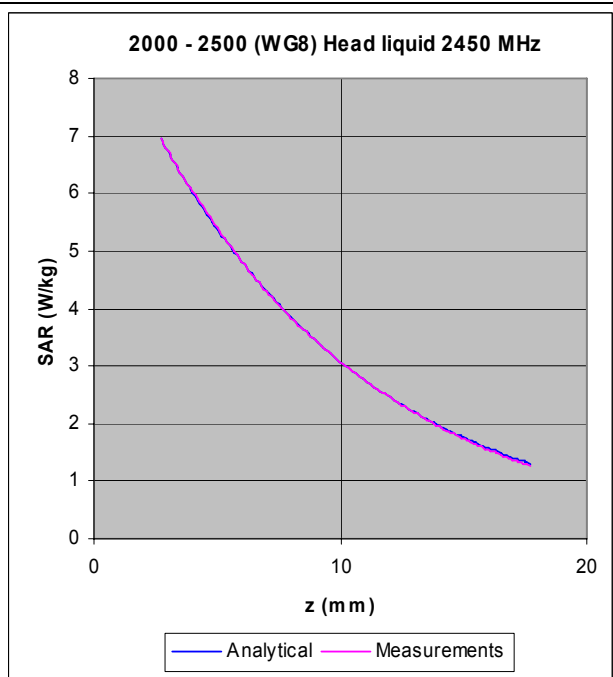
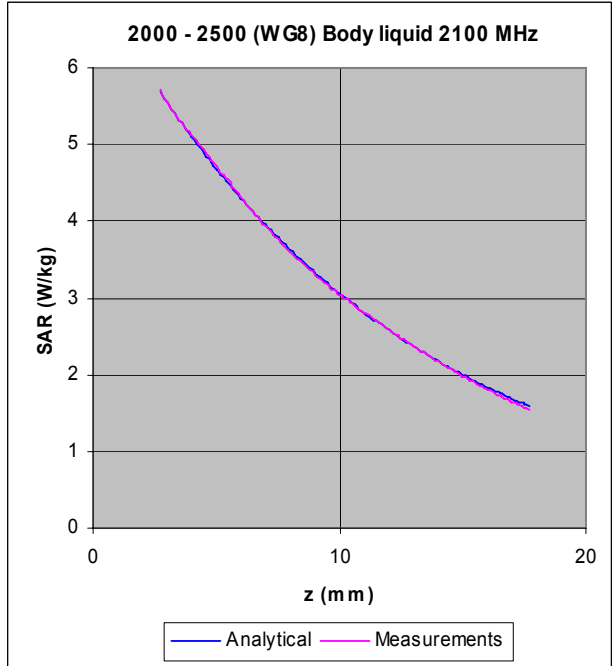
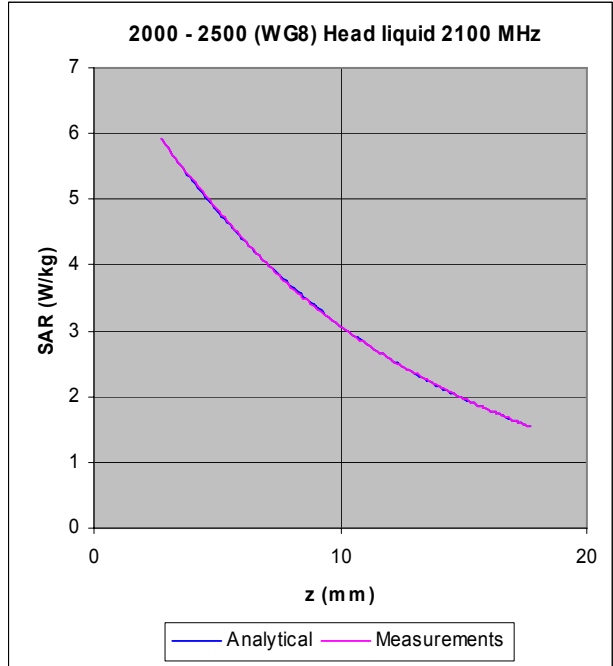

Figure 6. The measured SAR decay function along the centreline of the WG4 waveguide with conversion factors adjusted to fit to the theoretical function for the particular dimension, frequency, power and liquid properties employed.



D



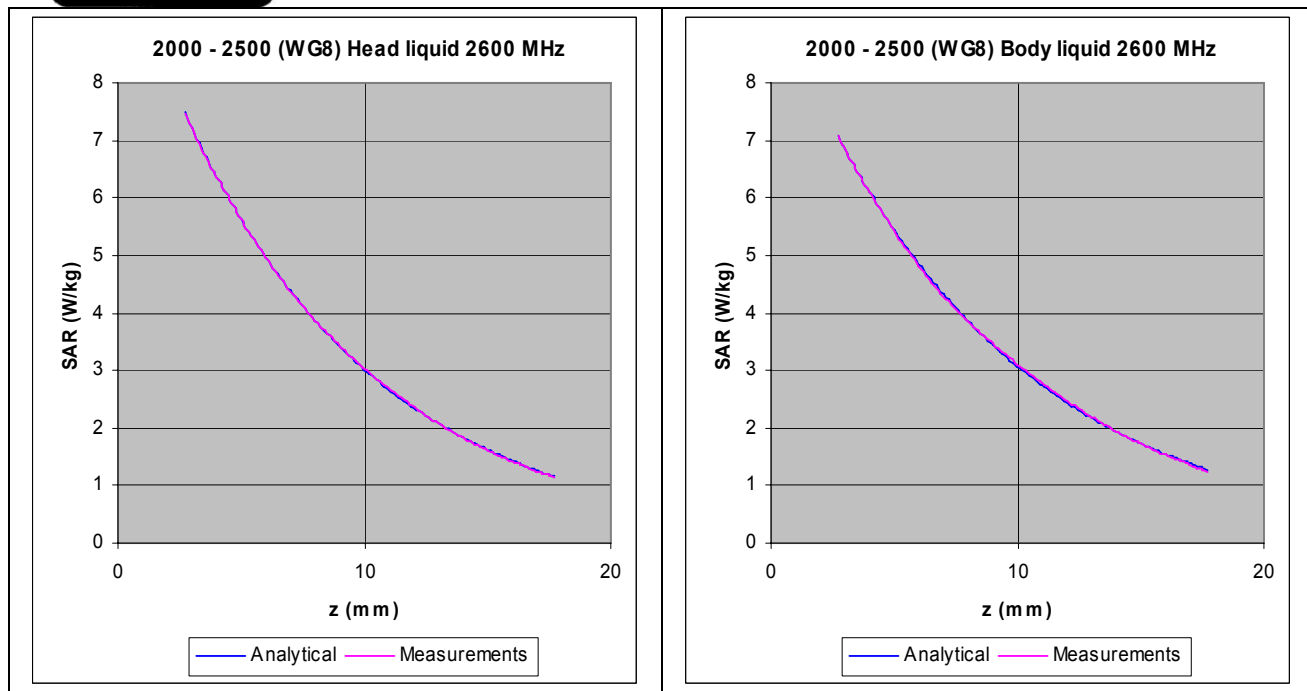

Figure 7. The measured SAR decay function along the centreline of the R22 waveguide with conversion factors adjusted to fit to the theoretical function for the particular dimension, frequency, power and liquid properties employed.

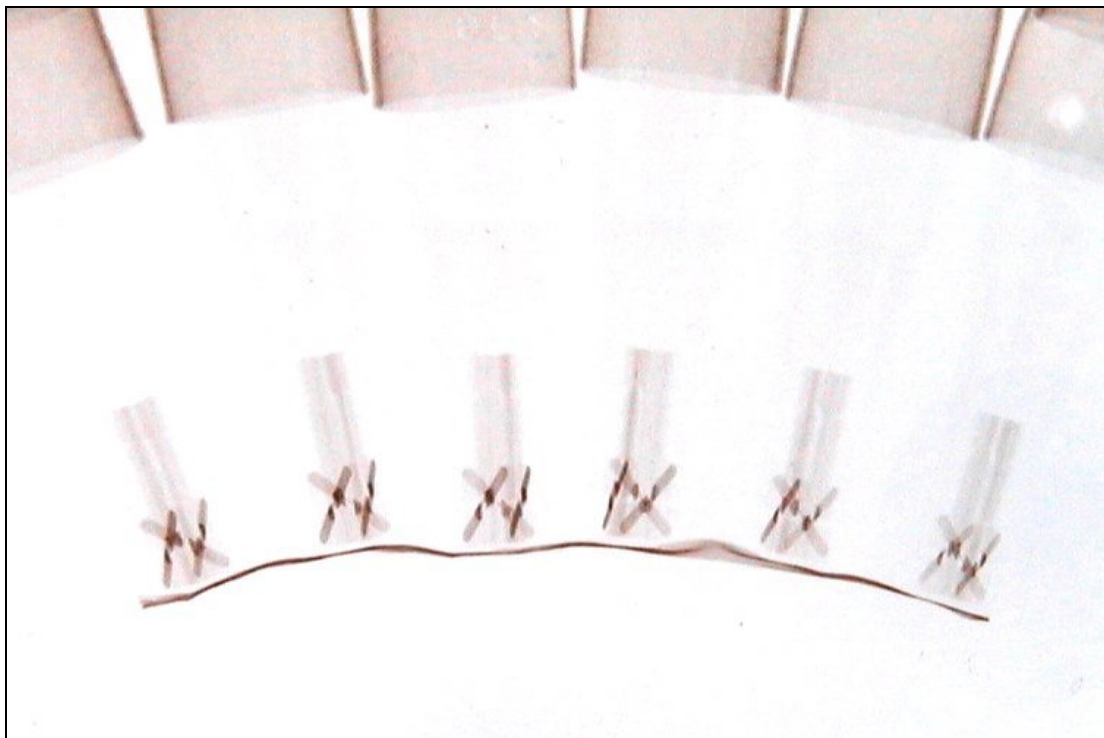

Figure 9: X-ray positive image of 5mm probes

Table indicating the dielectric parameters of the liquids used for calibrations at each frequency

Frequency (MHz)	BRAIN		BODY	
	Relative permittivity (measured)	Conductivity (S/m) (measured)	Relative permittivity (measured)	Conductivity (S/m) (measured)
450	44.28	0.847	57.57	0.856
835	42.00	0.916	55.98	0.990
900	41.42	0.978	55.45	1.054
1800	39.01	1.435	53.14	1.555
1900	39.67	1.440	53.98	1.539
2100	39.22	1.521	53.64	1.677
2450	37.95	1.865	52.54	2.061
2600	37.21	2.057	52.08	2.221

Table of test equipment calibration status

Instrument description	Supplier / Manufacturer	Model	Serial No.	Last calibration date	Calibration due date
Power sensor	Rohde & Schwarz	NRP-Z23	100063	16/06/2008	16/6/2010
Dielectric property measurement	Indexasar	DiLine (sensor lengths: 160mm, 80mm and 60mm)	N/A	(absolute) – checked against NPL values using reference liquids	N/A
Vector network analyser	Anritsu	MS6423B	003102	09/10/2008	12/01/2010
SMA autocalibration module	Anritsu	36581KKF/1	001902	09/10/2008	12/01/2010



Report No. SN0217_0812
9th December 2008

INDEXSAR
1900 MHz Validation Dipole
Type IXD-190 S/N 0217

Performance measurements

Dr Tony Brinklow

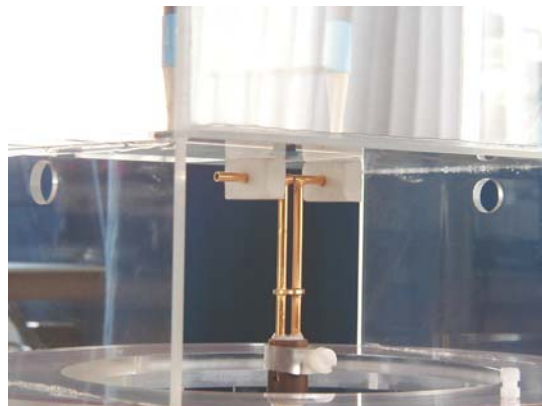

**Indexsar, Oakfield House, Cudworth Lane,
Newdigate, Surrey RH5 5BG. UK.**
Tel: +44 (0) 1306 632 870 Fax: +44 (0) 1306 631 834
E-mail: enquiries@indexsar.com

Measurement Conditions

Measurements were performed using a box-shaped phantom made of PMMA with dimensions designed to meet the accuracy criteria for reasonably-sized phantoms that do not have liquid capacities substantially in excess of the volume of liquid required to fill the Indexsar upright SAM phantoms used for SAR testing of handsets against the ear. The wall thickness was 2mm.

An Anritsu MS4623B vector network analyser was used for the return loss measurements. The dipole was placed in a special holder made of low-permittivity, low-loss materials. This holder enables the dipole to be positioned accurately in the centre of the wall of the Indexsar box-phantom used for flat-surface testing and validation checks.

The validation dipoles are supplied with special spacers made from a low-permittivity, low-loss foam material. These spacers are fitted to the dipole arms to ensure that, when the dipole is offered up to the phantom surface, the spacing between the dipole and the liquid surface is accurately aligned according to the guidance in the relevant standards documentation [1]. The spacers are rectangular with a central hole equal to the dipole arm diameter and dimensioned so that the longer side can be used to ensure a spacing of 15mm from the liquid in the phantom (for tests at 1000MHz and below) and the shorter side can be used for tests at 1000MHz and above to ensure a spacing of 10mm from the liquid in the phantom. The spacers are made on a CNC milling machine with an accuracy of $1/40^{\text{th}}$ mm but they may suffer wear and tear and need to be replaced periodically. The material used is Rohacell, which has a relative permittivity of approx. 1.05 and a negligible loss tangent.

The apparatus supplied by Indexsar for dipole validation tests thus includes:

Balanced dipoles for each frequency required are dimensioned according to the guidelines given in IEEE 1528 [1]. The dipoles are made from semi-rigid 50 Ohm co-ax, which is joined by soldering and is gold-plated subsequently. The constructed dipoles are easily deformed, if mis-handled, and periodic checks need to be made of their symmetry.

Rohacell foam spacers designed for presenting the dipoles to 2mm thick PMMA box phantoms. These components also suffer wear and tear and should be replaced when the central hole is a loose-fit on the dipole arms or if the edges are too worn to ensure accurate alignment. The standard spacers are dimensioned for use with 2mm wall thickness (additional spacers are available for 4mm wall thickness).

Dipole impedance and return loss

The dipoles are designed to have low return loss ONLY when presented against a lossy-phantom at the specified distance. A Vector Network Analyser (VNA) was used to perform a return loss measurement on the specific dipole when in the measurement-location against the box phantom. The distance was as specified in the standard i.e. 15mm from the liquid (for 1900MHz). The Indexsar foam spacers (described above) were used to ensure this condition during measurement.

The impedance was measured at the SMA-connector with the network analyser. The following parameters were measured against Head fluid:

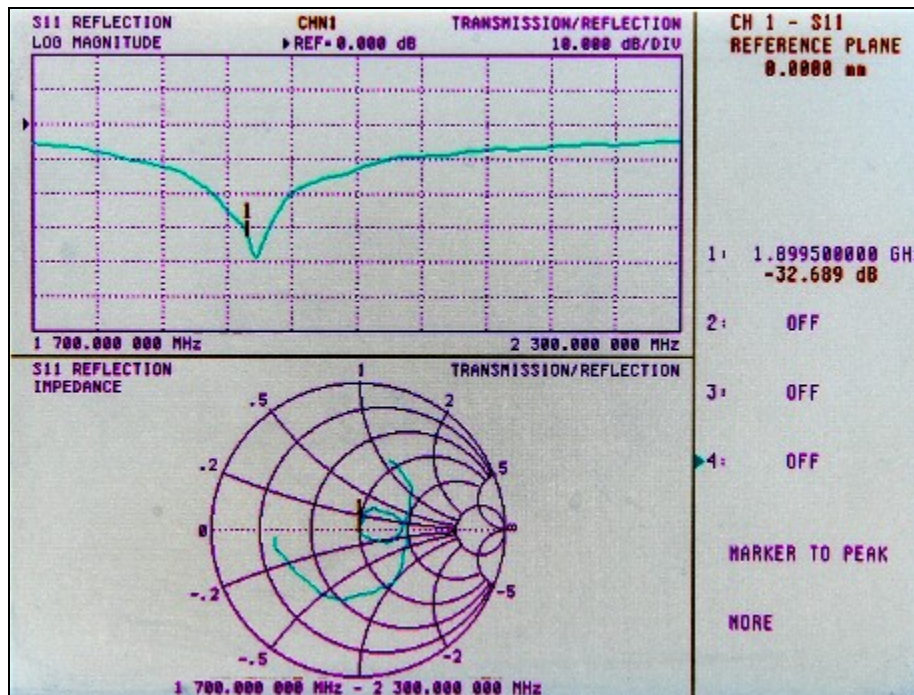

Dipole impedance at 1900 MHz $Re\{Z\} = 49.9 \Omega$
 $Im\{Z\} = -2.0 \Omega$

Return loss at 1900MHz **-32.7 dB**

The measurements were also repeated against 1900 Body fluid:

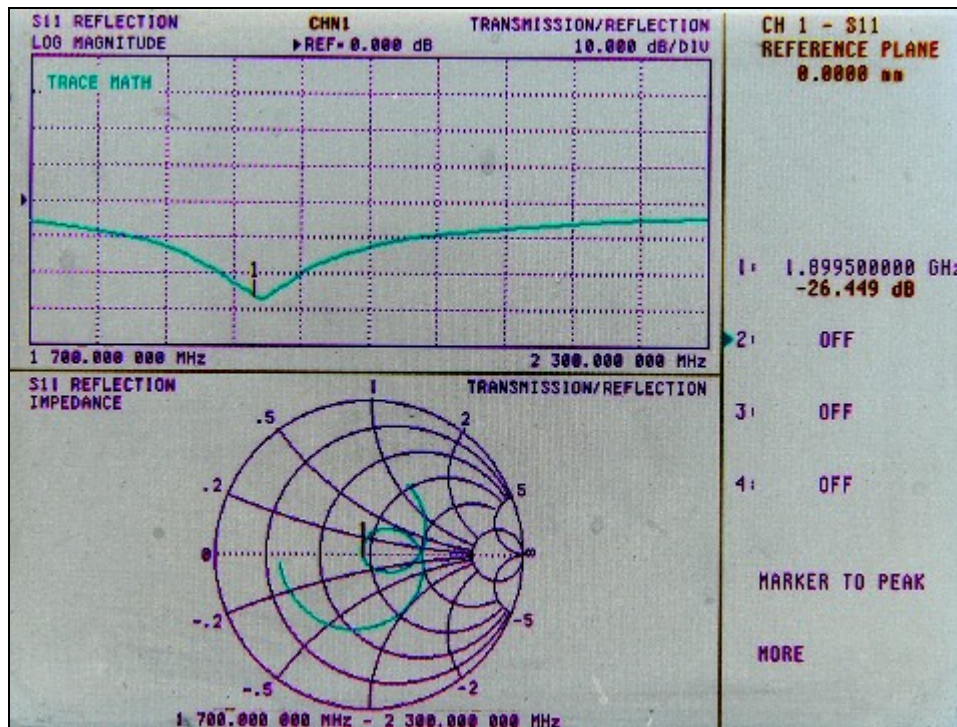

Dipole impedance at 1900 MHz $\text{Re}\{Z\} = 45.5 \Omega$
 $\text{Im}\{Z\} = -0.8 \Omega$

Return loss at 1900MHz **-26.4 dB**

SAR Validation Measurement in Brain Fluid

SAR validation checks have been performed using the 1900MHz dipole and the box-phantom located on the SARA2 phantom support base on the SARA2 robot system. Tests were then conducted at a feed power level of approx. 0.25W. The actual power level was recorded and used to normalise the results obtained to the standard input power conditions of 1W (forward power). The ambient temperature was 21°C +/- 1°C and the relative humidity was around 35% during the measurements.

The phantom was filled with a 1900MHz brain liquid using a recipe from [1], which has the following electrical parameters (measured using an Indexsar DiLine kit) at 1900MHz at the measurement temperature:

Relative Permittivity **39.18**
Conductivity **1.57 S/m**

The SARA2 software version 2.54 VPM was used with Indexsar IXP_050 probe Serial Number 0127 previously calibrated using waveguides.

The 3D measurement made using the dipole at the bottom of the phantom box is shown below:

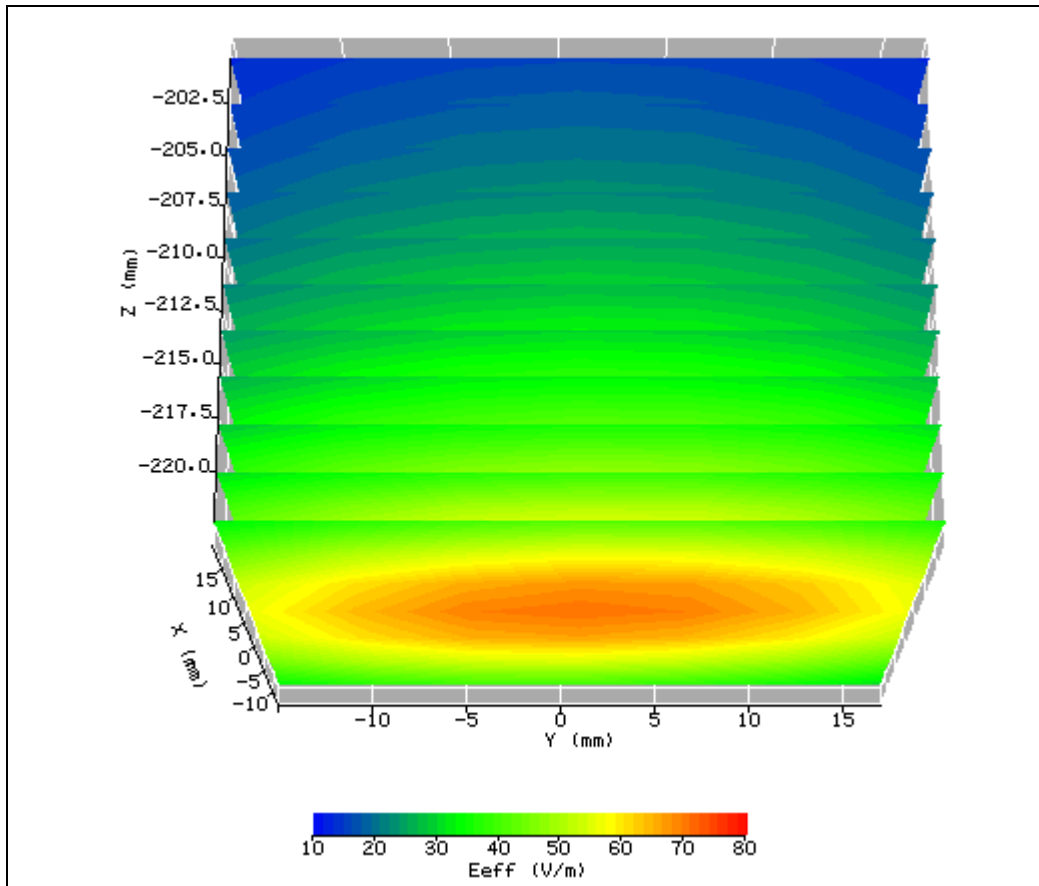

SAR measurement standard 62209-1 [ref 2] tabulates the volume-averaged 1g and 10g SAR values over a range of frequencies up to 3000MHz. The following values are listed for 1900MHz:

	SAR values (W/kg) (Normalised to 1W feed power)
1g SAR	39.7
10g SAR	20.5

The validation results, also normalised to an input power of 1W (forward power) were:

	Measured SAR values (W/kg) (Normalised to 1W feed power)	% Deviation from Standard
1g SAR	39.7	0.0%
10g SAR	21.2	+3.2%

SAR Measurement in Body Fluid

SAR validation checks are only defined in the standard against brain simulant fluid. Nonetheless, it is possible to measure the effective volume-averaged SAR values against body fluid, simply to provide a reference value.

The ambient temperature was $22^{\circ}\text{C} \pm 1^{\circ}\text{C}$ and the relative humidity was around 32% during the measurements.

The phantom was filled with a 1900MHz body liquid using a recipe from [1], which has the following electrical parameters (measured using an Indxsar DiLine kit) at 1900MHz at the measurement temperature:

Relative Permittivity	54.01
Conductivity	1.55 S/m

The SARA2 software version 2.54 VPM was used with Indxsar IXP_050 probe Serial Number 0127 previously calibrated using waveguides.

The 3D measurement made using the dipole at the bottom of the phantom box is shown below:

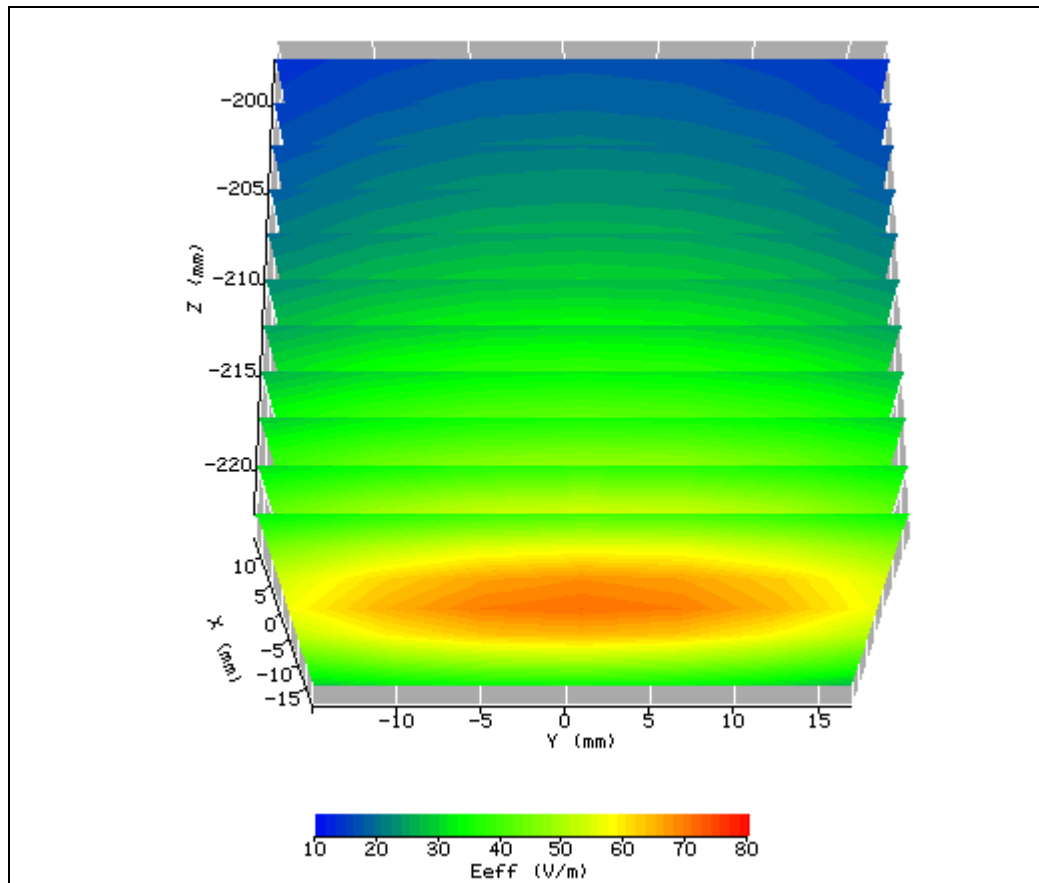

The validation results, also normalised to an input power of 1W (forward power) were:

	Measured SAR values (W/kg) (Normalised to 1W feed power)	% Deviation from Standard
1g SAR	38.8	N/A
10g SAR	20.7	N/A

Dipole handling

The dipoles are made from standard, copper-sheathed coaxial cable. In assembly, the sections are joined using ordinary soft-soldering. This is necessary to avoid excessive heat input in manufacture, which would destroy the polythene dielectric used for the cable. The consequence of the construction material and the assembly technique is that the dipoles are fragile and can be deformed by rough handling. Conversely, they can be straightened quite easily as described in this report.

If a dipole is suspected of being deformed, a normal workshop lathe can be used as an alignment jig to restore the symmetry. To do this, the dipole is first placed in the headstock of the lathe (centred on the plastic or brass spacers) and the headstock is rotated by hand (do NOT use the motor). A marker (lathe tool or similar) is brought up close to the end of one dipole arm and then the headstock is rotated by 0.5 rev. to check the opposing arm. If they are not balanced, judicious deformation of the arms can be used to restore the symmetry.

If a dipole has a failed solder joint, the dipole can be fixed down in such a way that the arms are co-linear and the joint re-soldered with a reasonably-powerful electrical soldering iron. Do not use gas soldering irons. After such a repair, electrical tests must be performed as described below.

Please note that, because of their construction, the dipoles are short-circuited for DC signals.

Tuning the dipole

The dipole dimensions are based on calculations that assumed specific liquid dielectric properties. If the liquid dielectric properties are somewhat different, the dipole tuning will also vary. A pragmatic way of accounting for variations in liquid properties is to 'tune' the dipole (by applying minor variations to its effective length). For this purpose, Indexsar can supply short brass tube lengths to extend the length of the dipole and thus 'tune' the dipole. It cannot be made shorter without removing a bit from the arm. An alternative way to tune the dipole is to use copper shielding tape to extend the effective length of the dipole. Do both arms equally.

It should be possible to tune a dipole as described, whilst in place in the measurement position as long as the user has access to a VNA for determining the return loss.

References

[1] IEEE Std 1528-2003. IEEE recommended practice for determining the peak spatial-average specific absorption rate (SAR) in the human body due to wireless communications devices: Measurement Techniques – Description.

[2] BS EN 62209-1:2006 Human exposure to radio frequency fields from hand-held and body-mounted wireless communication devices — Human models, instrumentation, and procedures — Part 1: Procedure to determine the specific absorption rate (SAR) for hand-held devices used in close proximity to the ear (frequency range of 300 MHz to 3 GHz)