



AT&T

Abridged user's manual

CL83519

DECT 6.0 cordless telephone/
answering system with
caller ID/call waiting

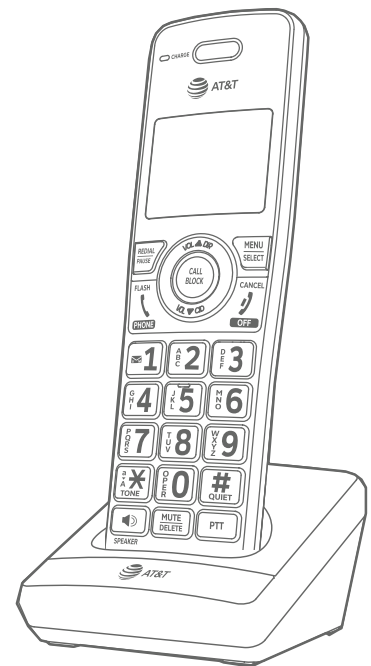
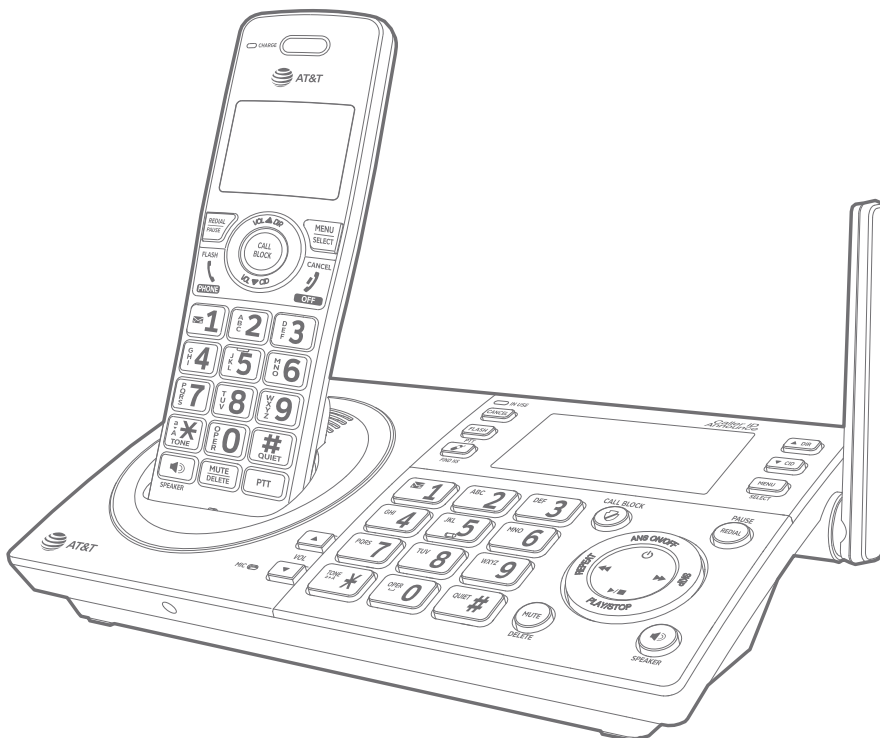

This Abridged user's manual provides you with basic installation and major operation instructions. A limited set of features are described in an abridged form.

Please refer to the online **CL83519 DECT 6.0 cordless telephone/answering system with caller ID/call waiting** Complete user's manual for a full set of installation and operation instructions at **www.telephones.att.com/manuals**.

This telephone system is compatible with certain AT&T DECT 6.0 cordless headsets and speakerphones. Visit **www.telephones.att.com/accessories** for a list of compatible cordless headsets and speakerphones.

For customer service, visit our website at **www.telephones.att.com** or call **1 (800) 222-3111**. In Canada, dial **1 (866) 288-4268**.

Model number: CL83519 (five handsets)

Type: DECT 6.0 cordless telephone/answering system with caller ID/call waiting

Serial number: _____

Purchase date: _____

Place of purchase: _____

Both the model and serial numbers of your AT&T product can be found on the bottom of the telephone base.

Save your sales receipt and original packaging in case it is necessary to return your telephone for warranty service.



Telephones identified with this logo have reduced noise and interference when used with most T-coil equipped hearing aids and cochlear implants. The TIA-1083 Compliant Logo is a trademark of the Telecommunications Industry Association. Used under license.



The ENERGY STAR® program (www.energystar.gov) recognizes and encourages the use of products that save energy and help protect our environment. We are proud to mark this product with the ENERGY STAR® label indicating it meets the latest energy efficiency guidelines.

Parts checklist

Your telephone package contains the following items. Save your sales receipt and original packaging in the event warranty service is necessary.

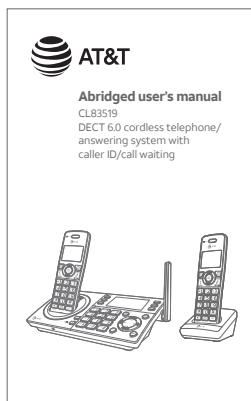

Abridged user's manual

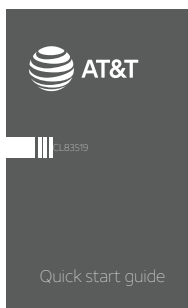

Quick start guide



Five cordless handsets



Telephone base

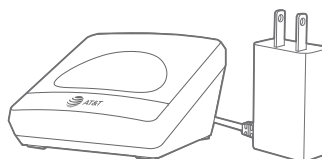

Four chargers for cordless handsets with power adapters installed



Five batteries for cordless handsets

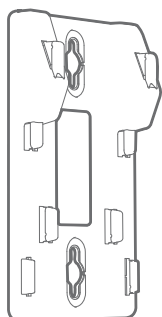

Wall-mount bracket



Five battery compartment covers

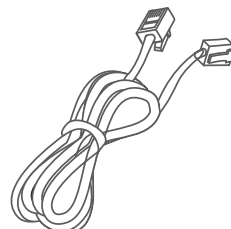

Telephone line cord

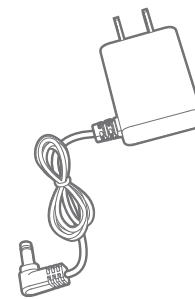

Power adapter for telephone base

Abridged user's manual

CL83519

DECT 6.0 cordless telephone/
answering system with
caller ID/call waiting



For more detailed instructions, refer to the Complete user's manual at www.telephones.att.com/manuals.

Table of contents

Getting started

Quick reference guide - handset	1
Quick reference guide - telephone base.....	4
Telephone base and charger installation.....	7
Telephone base installation.....	7
Charger installation	7
Battery installation and charging.....	9
Battery backup mode.....	12
To activate the mode	12
Operation.....	12
Installation options.....	13
Tabletop to wall-mount installation	13

Telephone settings

Handset settings.....	14
Ringer volume	14
Ringer tone.....	14
Set date/time	15
LCD language	16
Caller ID announce	16

Set speed dial voicemail number.....	17
Voicemail (visual message waiting) indicator	17
Clear voicemail indication	18
Key tone.....	18
Home area code.....	19
Dial mode.....	19
QUIET mode.....	20
Telephone base settings	21
Ringer volume	21
Ringer tone.....	21
Set date/time	22
LCD language	23
Caller ID announce	23
Set speed dial voicemail number.....	24
Voicemail (visual message waiting) indicator	24
Clear voicemail indication	25
Key tone.....	25
Home area code.....	26
Dial mode.....	26

Telephone operation

Telephone operation.....	27
Making a call	27
Answering a call.....	27
Ending a call	27
Handset speakerphone.....	27
Last number redial	28
Equalizer	28
Volume control	28
Call waiting.....	29
Mute	29
Options while on calls.....	30
Chain dialing.....	30
Blind transfer.....	31

Multiple handset use

Multiple handset use	33
Handset locator.....	33
Intercom	34
Push-to-talk (PTT)	36
Turn PTT on or off	36
PTT call to a single device.....	36
PTT call to multiple devices.....	37
Answer a PTT call	38

Directory

Directory.....	39
Create a new directory entry.....	39
Review the directory	40
Review directory entries	40
Search by name.....	40
Delete a directory entry	40
Edit a directory entry.....	41
Speed dial.....	42
Assign a speed dial number	42
Assign your voicemail speed dial number	42
Make a call using speed dial.....	42
Check your voicemail using speed dial.....	42

Caller ID

Caller ID	43
Missed (new) call indicator	43
Review the caller ID log.....	43
View dialing options	43
Dial a caller ID log entry	44
Save a caller ID log entry to the directory.....	44

Smart call blocker

About Smart call blocker*	45
Call categories.....	46
Call controls	47
Call block settings.....	49
Set Smart call blocker on/off.....	49
Set profile	49
Control calls without numbers (Customized settings)	50
Control uncategorized calls (Customized settings)	51
Block list.....	53
Allow list.....	58
Star name list.....	63
Screening announcement.....	66
Voice guide to set Smart call blocker	69
Allowed calls.....	70
Allow calls without numbers	70
Allow uncategorized calls.....	70
Block calls without numbers	71
Block uncategorized calls.....	71
Screen calls without numbers	72
Answer call once	73
Send call to answering system ...	74
End call.....	74
Screen uncategorized calls.....	75
Allow call once.....	77
Always allow.....	77
Block call.....	78
Send call to answering system ...	78
Option while on a call.....	79

Answering system

Answering system settings	80
Announcement.....	80
Answer on/off.....	83
Voice guide to set Answering system	84
Call screening.....	85
Number of rings	85
Remote access code.....	86
Message alert tone	86
Message recording time.....	87
Answering system and voicemail indicators	88
About the answering system.....	89
Using the answering machine and voicemail together	89
Message capacity.....	89
Call screening.....	89
Call intercept.....	90
Temporarily turning off the message alert tone	90
Message playback.....	91
Options during playback.....	91
Delete all old messages	93
Recording and playing memos.....	94
Record a memo	94
Play back a memo.....	94
Remote access	95

Appendix

Adding and registering handsets/ headsets/speakerphones.....	96
Register a handset to the telephone base	96
Deregistering handsets.....	97
Deregister all handsets from the telephone base	97
Troubleshooting.....	98
Maintenance	104

Important safety information.....	105
Safety information.....	105
Especially about cordless telephones.....	106
Precautions for users of implanted cardiac pacemakers.....	107
Pacemaker patients.....	107
ECO mode.....	107
Especially about telephone answering systems.....	107
For C-UL compliance	108
Mesures de sécurité importantes.....	108
FCC Part 68 and ACTA.....	111
FCC Part 15.....	112
Limited warranty.....	113
Technical specifications.....	116
DECT 6.0 digital technology	116
Telephone operating range	116
Redefining long range coverage and clarity.....	116
HD audio.....	116
Simulated full-duplex handset and base speakerphones.....	116

Index

Index	117
-------------	-----

Quick reference guide - handset

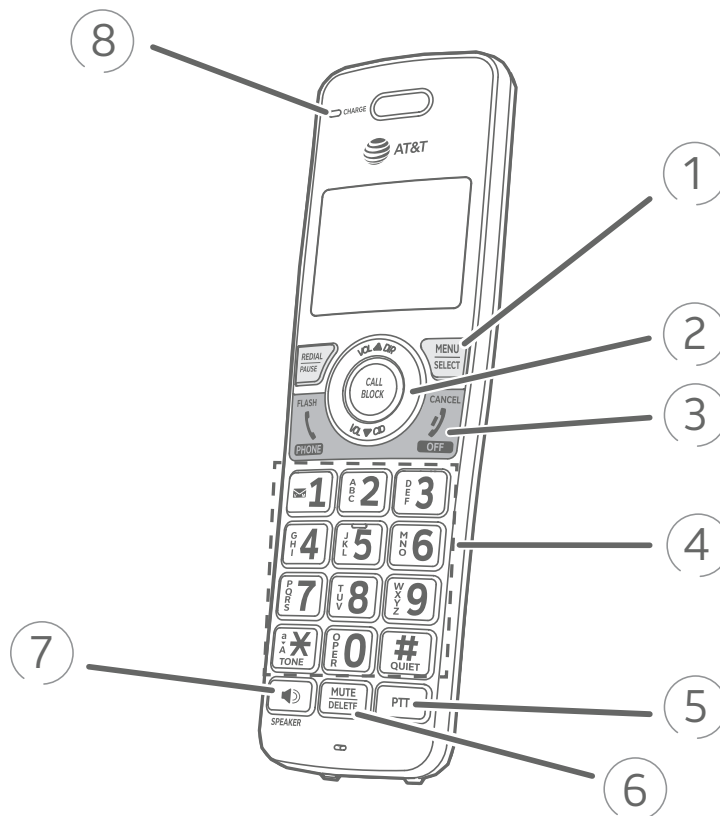

1 REDIAL/PAUSE

- ▶ Press repeatedly to view the last ten numbers dialed (page 28).
- ▶ While entering numbers, press and hold to insert a dialing pause (page 39).

MENU/SELECT

- ▶ When the handset is not in use, press to show the menu.
- ▶ While in the menu, press to select an item or save an entry or setting.

2 VOL ▲ DIR

- ▶ Press to display the directory entries when the phone is not in use (page 40).
- ▶ Press to scroll up while in menus and lists.
- ▶ While entering names or numbers, press to move the cursor to the right.
- ▶ Press to increase the listening volume when on a call (page 28), or to increase the message playback volume (page 91).

CALL BLOCK

- ▶ Press to block the incoming call when the telephone is ringing (page 78).
- ▶ When on a call, press to block the call (page 79).
- ▶ When the handset is not in use, press to show the call block menu (page 49).

VOL ▼ CID

- ▶ Press to show caller ID log when the handset is not in use (page 43).
- ▶ Press to scroll down while in menus.
- ▶ While entering names or numbers, press to move the cursor to the left.
- ▶ Press to decrease the listening volume when on a call (page 28), or to decrease the message playback volume (page 91).

Quick reference guide - handset

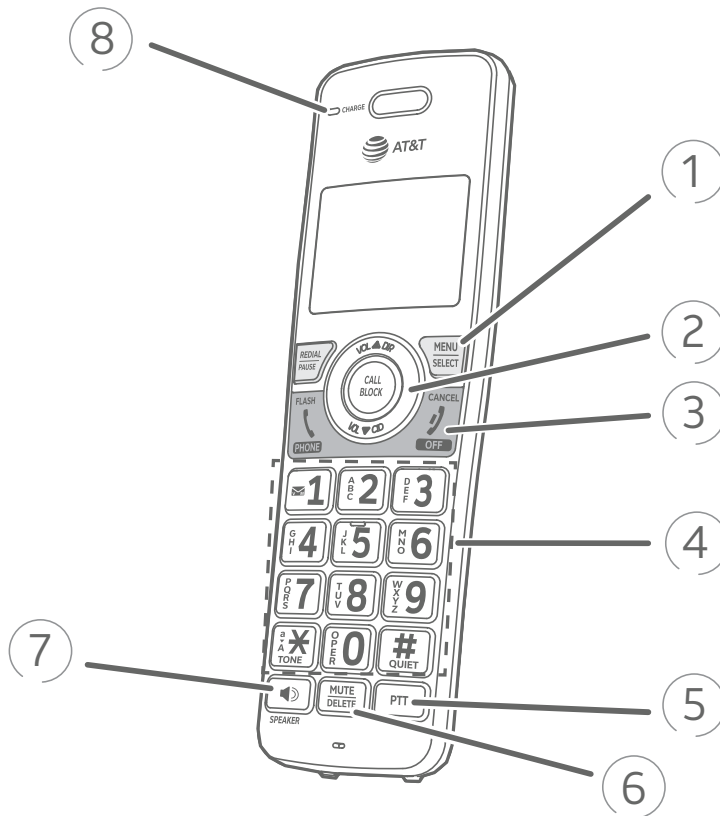

3 PHONE/FLASH

- ▶ Press to make or answer a call (page 27).
- ▶ During a call, press to answer an incoming call when you receive a call waiting alert (page 29).
- ▶ During message playback, press to call back the caller if the caller's number is available (page 91).

OFF/CANCEL

- ▶ During a call, press to hang up (page 27).
- ▶ While in a menu, press to cancel an operation, back up to the previous menu, or exit the menu display; or press and hold this button to exit to idle mode.
- ▶ When the handset is ringing, press to mute the ringer temporarily (page 29).

- ▶ Press and hold while the telephone is not in use to erase the missed call indicator (page 43).

4 1

- ▶ While reviewing a caller ID log entry, press repeatedly to add or remove 1 in front of the telephone number before dialing or saving it in the directory (page 43).
- ▶ Press and hold to set (page 17) or to dial your voicemail number (page 42).

TONEX/a>A

- ▶ Press to switch to tone dialing temporarily during a call if you have pulse service.
- ▶ While entering names, press to change the next letter to upper or lower case (page 39).

Getting started

Quick reference guide - handset

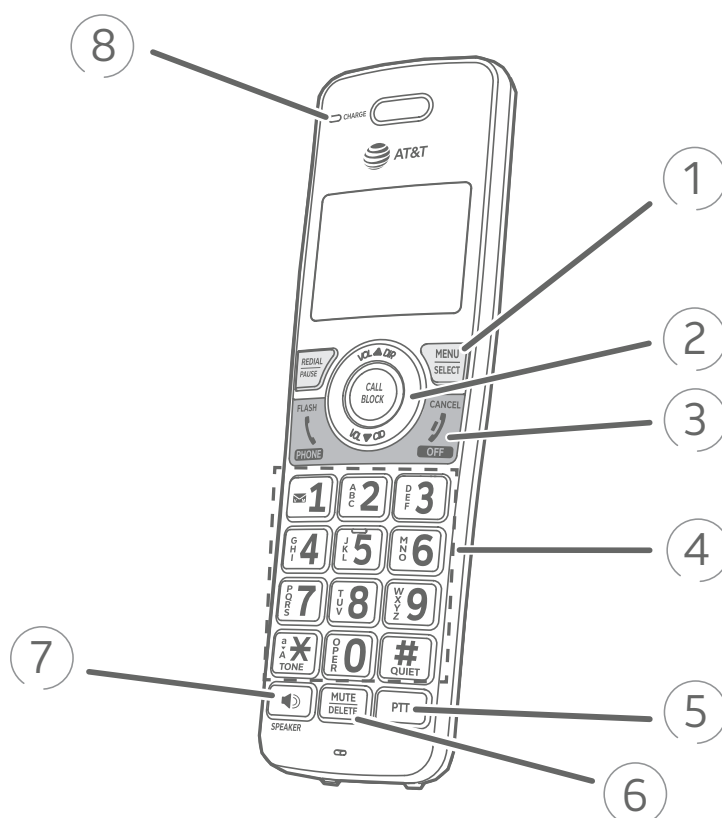

4 QUIET# (pound key)

- ▶ Press repeatedly to display other dialing options when reviewing a caller ID log entry (page 43).
- ▶ Press and hold to enter the **QUIET** mode setting screen, or to deactivate **QUIET** mode (page 20).

5 PTT

- ▶ Press to initiate a one-to-one or one-to-group broadcast.
- ▶ Press and hold to broadcast to a group of system devices.

6 MUTE/DELETE

- ▶ During a call, press to mute the microphone (page 29).
- ▶ When the handset is ringing, press to mute the ringer temporarily.

- ▶ While reviewing the caller ID log, directory, redial memory, allow list, block list, or star name list, press to delete an individual entry.
- ▶ While predialing, press to delete digits.
- ▶ During message or announcement playback, press to delete the playing message or the recorded announcement.

7 /SPEAKER

- ▶ Press to make or answer a call using the speakerphone (page 27).
- ▶ Press to switch between the speakerphone and the handset (page 27).

8 **CHARGE** light

- ▶ On when the handset is charging in the telephone base or charger.

Quick reference guide - telephone base

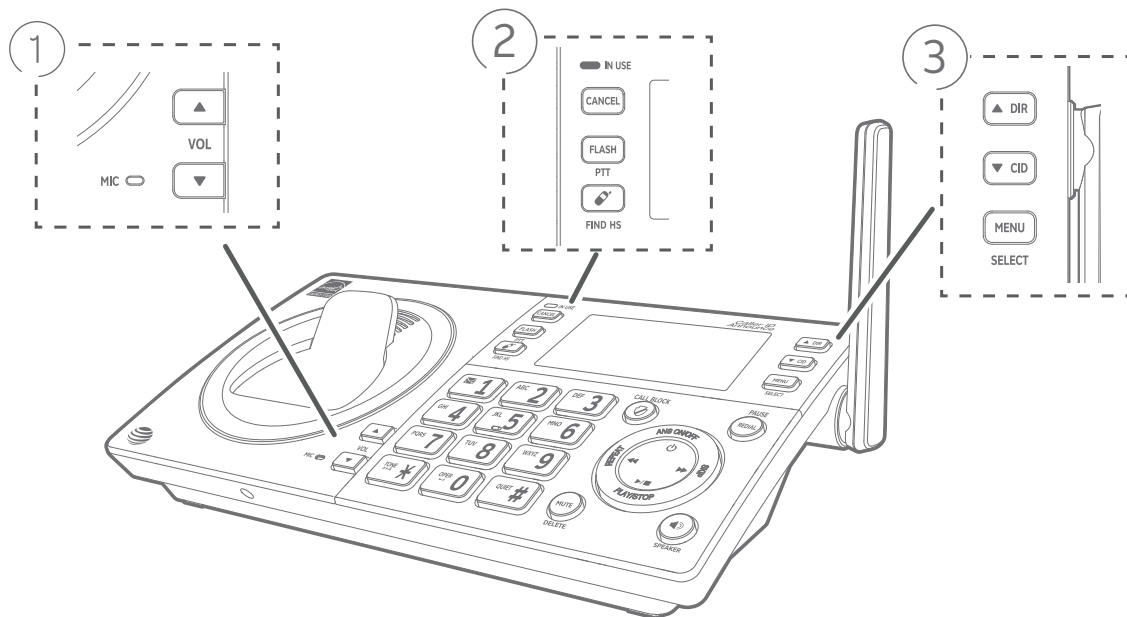

1 MIC Microphone

▼/VOL/▲

- ▶ During message playback or call screening, press to adjust the listening volume (page 28).
- ▶ While in idle mode, press to adjust the base ringer volume.
- ▶ When on a call, press to adjust the listening volume.

2 IN USE light

- ▶ On when the telephone is in use, or when the answering system is answering an incoming call.
- ▶ On when a handset is being registered.
- ▶ Flashes when there is an incoming call or when all handsets are being deregistered.
- ▶ Flashes when another telephone is in use on the same line.

CANCEL

- ▶ While in a menu, press to cancel an operation, back up to the previous menu or exit the menu display; or press and hold to go back to idle mode.

- ▶ When the telephone base is ringing, press to mute the ringer temporarily.
- ▶ When the telephone base is not in use, press and hold to erase the missed call indicator.

FLASH/PTT

- ▶ Press to initiate a one-to-one (page 36) or one-to-group broadcast (page 37).
- ▶ Press and hold to broadcast to a group of system devices (page 37).
- ▶ During a call, press to answer an incoming call when you receive a call waiting alert.

🔍/FIND HS

While the phone is idle, press to page all handsets (page 33).

3 ▲DIR

- ▶ Press to display the directory when the phone is not in use (page 40).
- ▶ Press to scroll up while in menus and lists.
- ▶ While entering names or numbers, press to move the cursor to the right.

Quick reference guide - telephone base

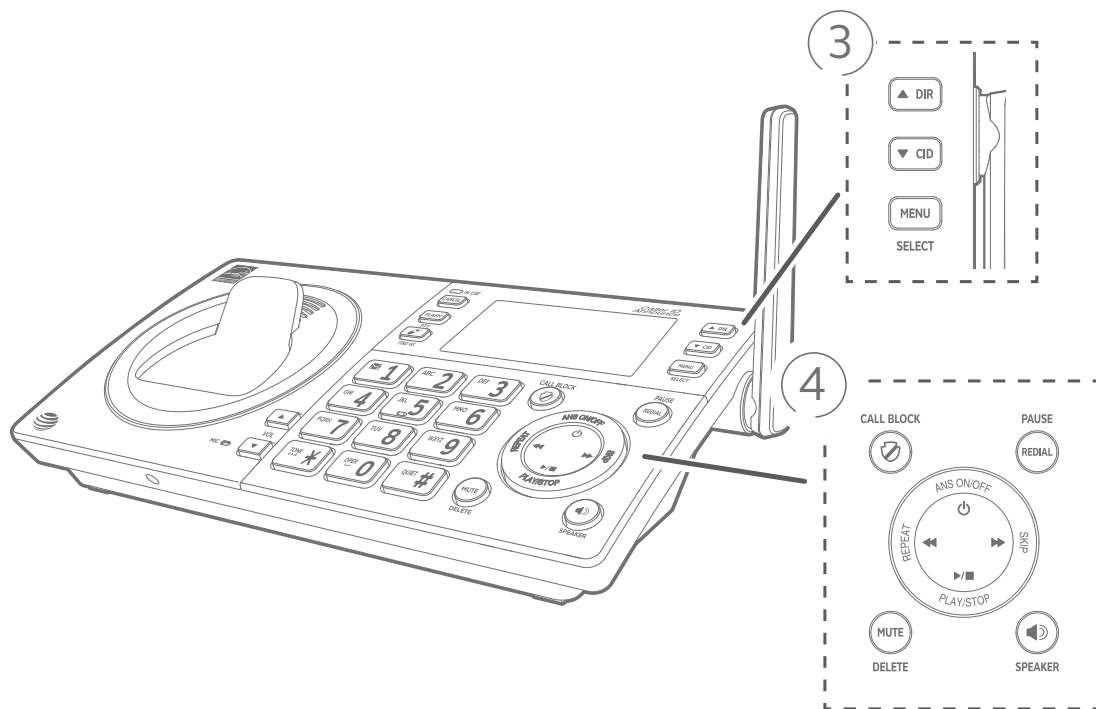

3 ▼CID

- ▶ Press to display the caller ID log when the phone is not in use (page 43).
- ▶ Press to scroll down while in menus and lists.
- ▶ While entering names or numbers, press to move the cursor to the left.

MENU/SELECT

- ▶ When the telephone base is not in use, press to show the menu.
- ▶ While in the menu, press to confirm or save an entry or setting.

4 ◻/CALL BLOCK

- ▶ Press to block the incoming call when the telephone is ringing (page 78).
- ▶ When on a call, press to block the call (page 79).
- ▶ When the handset is not in use, press to show the call block menu (page 49).

REIDIAL/PAUSE

- ▶ Press repeatedly to view the last 10 numbers dialed (page 28).
- ▶ While entering numbers, press and hold to insert a dialing pause.

⏻/ANSWER ON

Press to turn the built-in answering system on or off (page 83).

◀/REPEAT

- ▶ During playback, press to repeat the playing message (page 91).
- ▶ During playback, press twice to play the previous message (page 91).

▶▶/SKIP

Press to skip a message (page 91).

▶■/PLAY/STOP

Press to start or stop message playback (page 91).

Quick reference guide - telephone base

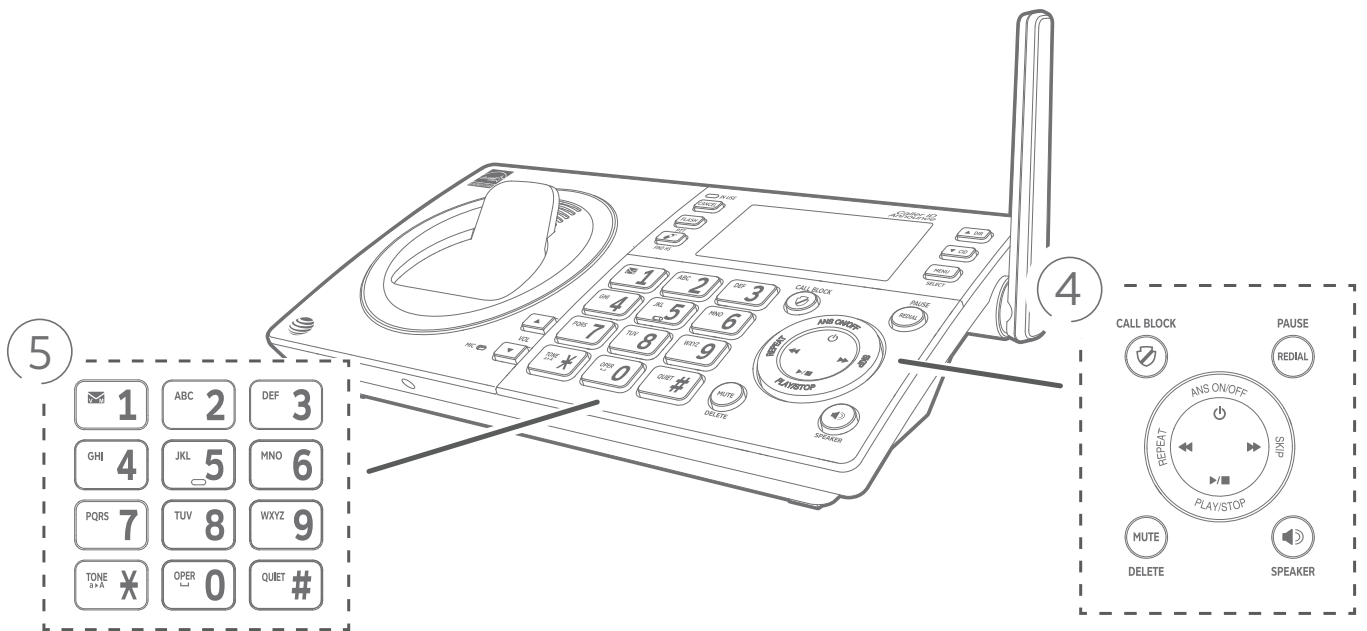

4 MUTE/DELETE

- ▶ While reviewing the caller ID log, directory, redial memory, allow list, block list, and star name list, press to delete an individual entry.
- ▶ While predialing, press to delete digits.
- ▶ During message or announcement playback, press to delete the playing message or announcement.
- ▶ Press twice to delete all old messages when the phone is not in use.
- ▶ During a call, press to mute the microphone (page 29).
- ▶ When the phone is ringing, press to mute the ringer temporarily.

/SPEAKER

Press to make or answer a call using the speakerphone.

TONEX/a>A

- ▶ Press to switch to tone dialing temporarily during a call if you have pulse service.
- ▶ While entering names, press to change the next letter to upper or lower case (page 39).

QUIET# (pound key)

- ▶ Press repeatedly to display other dialing options when reviewing a caller ID log entry (page 43).
- ▶ Press and hold to enter the **QUIET** mode setting screen, or to deactivate **QUIET** mode (page 20).

5 1

- ▶ Press and hold to set (page 24) or to dial your voicemail number (page 42).

Telephone base and charger installation

Install the telephone base and charger, as shown below.

Telephone base installation

Plug the large end of the telephone base power adapter into a power outlet not controlled by a wall switch.

Plug one end of the telephone line cord into a telephone jack or a DSL filter.

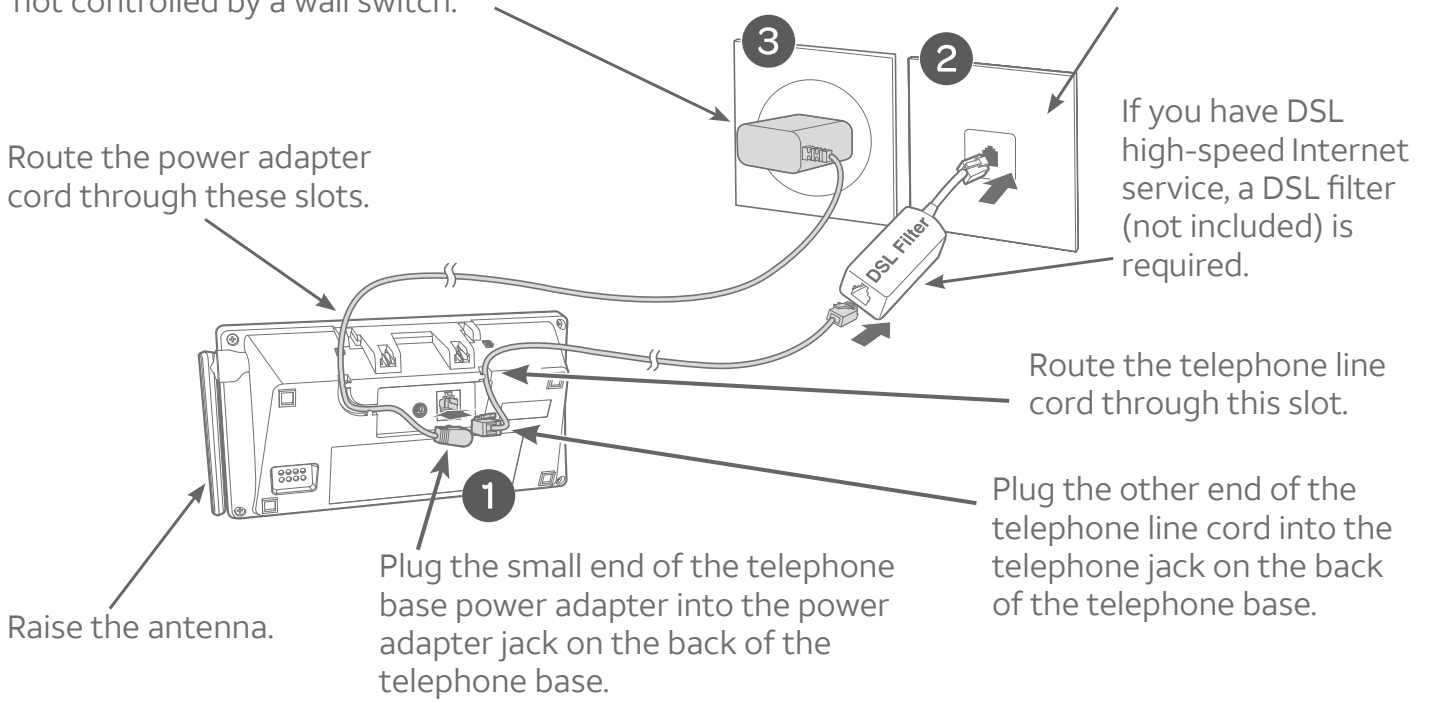

Charger installation

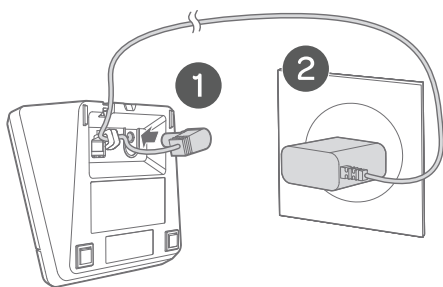

Plug the power adapter into a power outlet not controlled by a wall switch.



Telephone base and charger installation

IMPORTANT INFORMATION

- ▶ Use only the power adapter(s) supplied with this product. To order a replacement power adapter, visit our website at **www.telephones.att.com** or call **1 (800) 222-3111**. In Canada, dial **1 (866) 288-4268**. For more detailed instructions, refer to the online Complete user's manual at **www.telephones.att.com/manuals**.
- ▶ The power adapters are intended to be correctly oriented in a vertical or floor mount position. The prongs are not designed to hold the plug in place if it is plugged into a ceiling, under-the-table or cabinet outlet.
- ▶ Avoid placing the telephone base and charger too close to:
 - ▶ Communication devices such as television sets, VCRs, or other cordless telephones.
 - ▶ Excessive heat sources.
 - ▶ Noise sources such as a window with traffic outside, motors, microwave ovens, refrigerators, or fluorescent lighting.
 - ▶ Excessive dust sources such as a workshop or garage.
 - ▶ Excessive moisture.
 - ▶ Extremely low temperature.
 - ▶ Mechanical vibration or shock such as on top of a washing machine or workbench.

Battery installation and charging

Once you have installed the battery, the screen indicates the battery status (see the following table). For best performance, keep the handset in the telephone base or charger when not in use. The battery is fully charged after ten hours of continuous charging. See the table in the Technical specifications section on page 116 for battery operating times.

Battery indicators	Battery status	Action
The screen is blank, or shows Place in charger and  (flashing).	Battery has no or very little charge. The handset cannot be used.	Charge without interruption (at least 30 minutes).
The screen shows Low battery and  (flashing).	Battery has enough charge to be used for a short time.	Charge without interruption (at least 30 minutes).
The screen shows HANDSET X .	Battery is charged.	To keep the battery charged, place it in the telephone base or charger when not in use.

Step 1

Plug the battery connector securely into the socket inside the handset battery compartment. Insert the supplied battery with the label **THIS SIDE UP** facing up, as indicated.

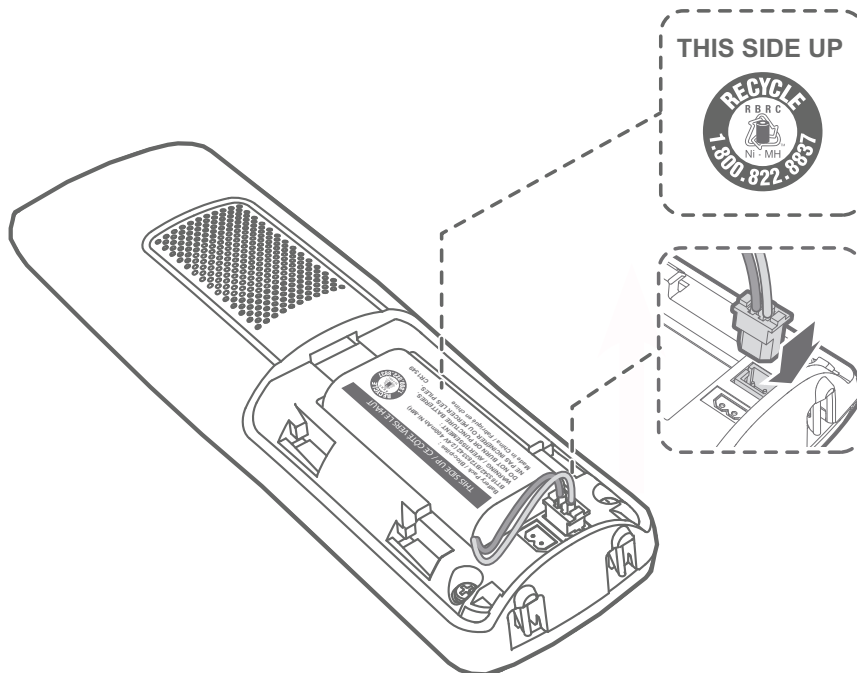

Battery installation and charging

Step 2

Align the cover flat against the battery compartment, then slide it upwards until it clicks into place.

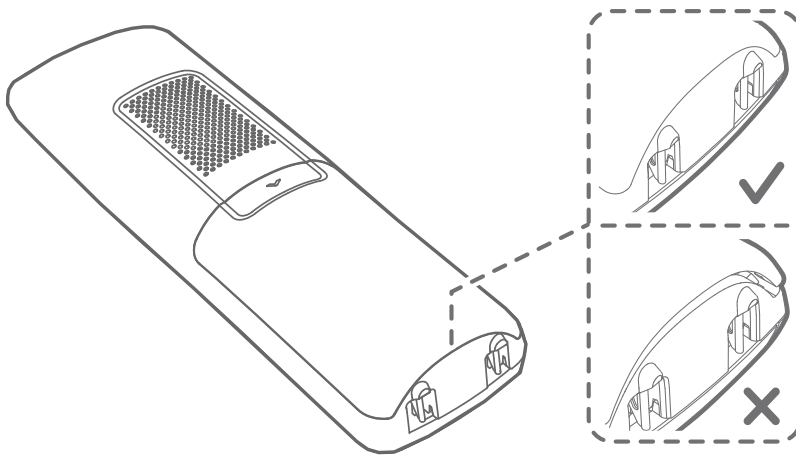
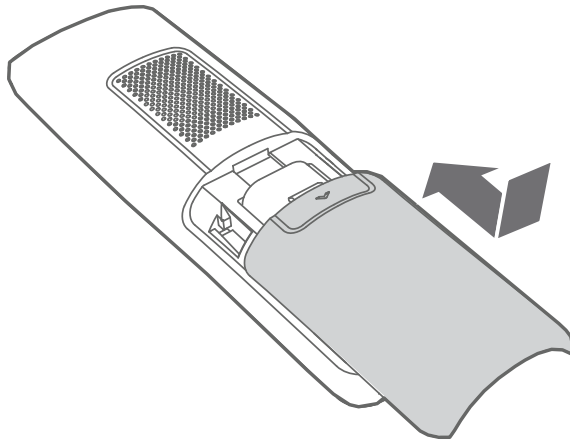

Step 3

Charge the handset by placing it face forward in the telephone base or charger. The **CHARGE** light on the handset is on during charging.

Battery installation and charging

After you install your telephone or power returns following a power outage, the handset and the telephone base will prompt you to set the date and time. For instructions, see **Set date/time** on page 15 or page 22. To skip setting the date and time, press **OFF/CANCEL** on the handset or **CANCEL** on the telephone base.



After the date and time setting is done or skipped, the telephone base then prompts if you want to set Smart call blocker. Press **MENU/SELECT** to start the Smart call blocker setup via voice guide. For more details, see **Voice guide to set Smart call blocker** on page 69. To skip the setup, press **CANCEL** on the telephone base.

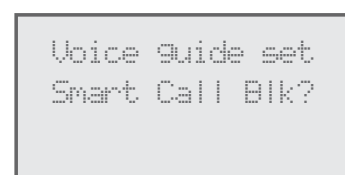

After the Smart call blocker setting is done or skipped, the telephone base will then prompt if you want to set up the answering system. Press **MENU/SELECT** to start the answering system setup via voice guide. For more details, see **Voice guide to set Answering system** on page 84. To skip the setup, press **CANCEL** on the telephone base.

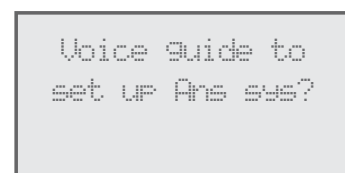

IMPORTANT INFORMATION

- ▶ Use only the supplied rechargeable battery or replacement battery (model BT183342/ BT283342). To order, visit our website at **www.telephones.att.com** or call **1 (800) 222-3111**. In Canada, dial **1 (866) 288-4268**.
- ▶ If you do not use the handset for a long time, disconnect and remove the battery to prevent possible leakage.

Battery backup mode

Battery backup mode allows your telephone system to function in the event of a power outage. The telephone system uses stored power from the handset's battery to operate.

To activate the mode

After the power goes out, if there is already a handset with enough charge placed in the telephone base, the telephone system enters battery backup mode automatically. That handset screen shows **Powering base... Don't pick up**. All other handset screens show **Pwr outage mode**.

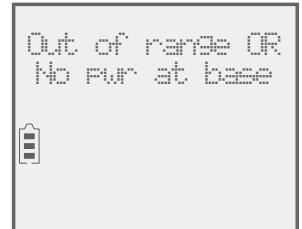

-OR-

If there is no handset placed in the telephone base after the power goes out, all handsets show **Out of range OR No pwr at base** and **Put HS on base to power base**, alternatively. Place any handset with enough charge in the telephone base. Its screen shows **Powering base... Don't pick up**. All other handset screens show **Pwr outage mode**.

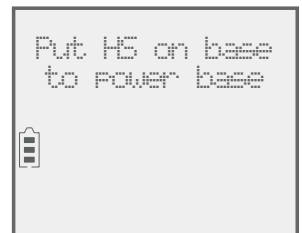

Note: A handset which does not have enough charge to power up the base, its screen shows **Out of range OR No pwr at base** and **Not enough batt to power base**, alternatively, after the power goes out. Find another system handset that has enough charge to activate the mode.

Operation

During battery backup mode, the telephone base and answering system will be disabled. The operating time is subject to the battery level of the handset placed in the telephone base and the actual usage. For optimal performance, you are not recommended to use the handset placed in the telephone base when this mode is on.

Using other system handsets (Recommended):

Operate the handsets the same way as usual, except the answering system which will be disabled.

Using the handset placed in the telephone base:

To maximize the operating time, you are not advised to use this handset. If you do have to use it, make sure you do not lift it from the telephone base. All operations should be done with the handset placed in the telephone base. In this case, calls can only be made and received using the speakerphone.

Installation options

Your telephone base is ready for tabletop use. If you want to mount your telephone on a wall, follow the steps, as mentioned below, to connect the telephone base with a standard dual-stud telephone wall-mounting plate. You may need a professional to install the mounting plate.

Tabletop to wall-mount installation

1. Plug the telephone line into the telephone base. If you are using a DSL filter, plug the other end of the telephone line into the filter. Route the telephone line cord (or DSL filter) through the wall-mount bracket hole.
2. Align the holes on the wall-mount bracket with the standard wall plate and slide the wall-mount bracket down until it locks securely.
3. Position the telephone base, as shown below. Insert the extended tabs (marked B) of the wall-mount bracket into the slots on the back of the telephone base. Push the telephone base down until it is securely in place.
4. Plug the power adapter into a power outlet not controlled by a wall switch. Plug the other end of the power adapter into the telephone base. Bundle the telephone line cord and power adapter cord neatly with twist ties.

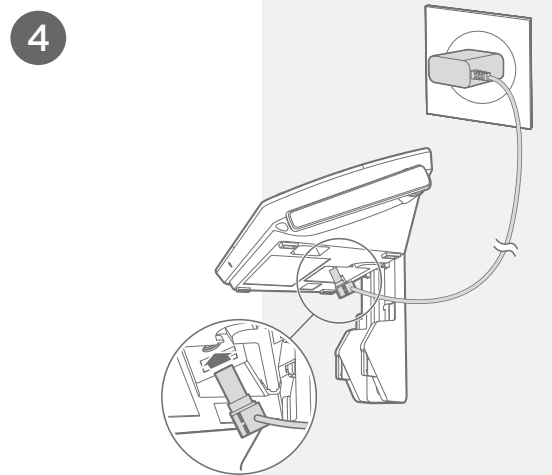
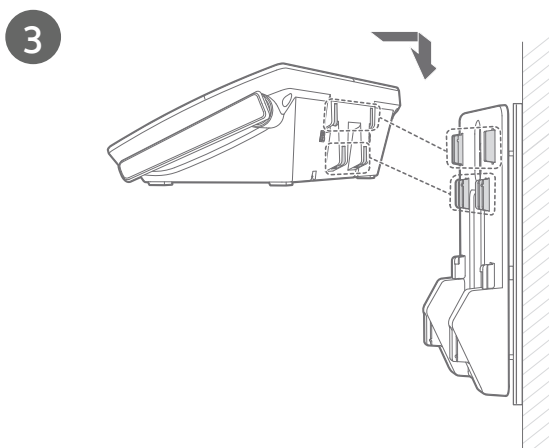
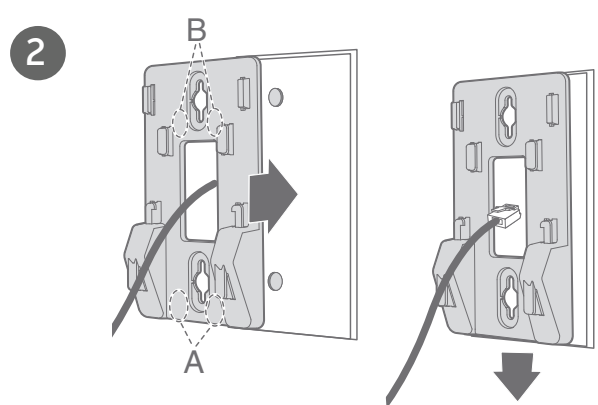
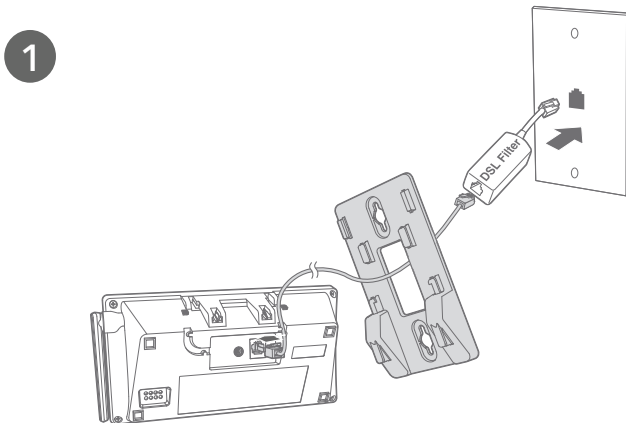

Handset settings

Use the menu to change the telephone settings.

1. Press **MENU/SELECT** on the handset when it is not in use to enter the main menu.
2. Press **▼CID** or **▲DIR** to scroll to the feature to be changed. When scrolling through the menu, the **>** symbol indicates the chosen menu item.
3. Press **MENU/SELECT** to select the chosen item.



 Note: Press **⏏/OFF/CANCEL** to cancel an operation, back up to the previous menu or exit the menu display. Press and hold **⏏/OFF/CANCEL** to return to idle mode.

Ringer volume

You can set the ringer volume level to one of the six levels or turn the ringer off. When the ringer is off,  appears on the screen.

1. Press **MENU/SELECT** in idle mode to enter the main menu.
2. Press **▼CID** or **▲DIR** to scroll to **Ringers**, then press **MENU/SELECT**.
3. Press **MENU/SELECT** again to select **Ringer volume**.
4. Press **▼CID** or **▲DIR** to sample each volume level.
5. Press **MENU/SELECT** to save your preference.

 Note: The handset ringer volume also determines the ringer volume for intercom calls.

Ringer tone

You can choose one of the ten ringer tones.

1. Press **MENU/SELECT** in idle mode to enter the main menu.
2. Press **▼CID** or **▲DIR** to scroll to **Ringers**, then press **MENU/SELECT**.
3. Press **▼CID** or **▲DIR** to scroll to **Ringer tone**, then press **MENU/SELECT**.
4. Press **▼CID** or **▲DIR** to sample each ringer tone.
5. Press **MENU/SELECT** to save your preference.

 Note: If you turn off the ringer volume, you will not hear ringer tone samples.

Handset settings

Set date/time

The answering system announces the day and time of each message prior to playing it. Before using the answering system, set the date and time as follows. If you subscribe to caller ID service, the day, month and time are set automatically with each incoming call. The year must be set so that the day of the week can be calculated from the caller ID information. You can turn off the date and time settings of the caller ID service and set the date and time manually.

1. When the handset is in idle mode, press **MENU/SELECT** to enter the main menu.
2. Press **▼CID** or **▲DIR** to scroll to **Set date/time**, then press **MENU/SELECT**.
3. Press **▼CID** or **▲DIR** to select the month, then press **MENU/SELECT**, or enter the number using the dialing keys.
4. Press **▼CID** or **▲DIR** to select the day, then press **MENU/SELECT**, or enter the number using the dialing keys.
5. Press **▼CID** or **▲DIR** to select the year, or enter the number using the dialing keys, then press **MENU/SELECT** to move on to set the time.
6. Press **▼CID** or **▲DIR** to select the hour, then press **MENU/SELECT**, or enter the number using the dialing keys.
7. Press **▼CID** or **▲DIR** to select the minute, then press **MENU/SELECT**, or enter the number using the dialing keys.
8. Press **▼CID** or **▲DIR** to select **AM** or **PM**, or press **2** for **AM** or **7** for **PM**. Press **MENU/SELECT** to confirm.

 Note: If the clock is not set when a message is recorded, the system announces, “*Time and day not set,*” before it plays the message.

Handset settings

LCD language

You can select the language used for all screen displays.

1. Press **MENU/SELECT** in idle mode to enter the main menu.
2. Press **▼CID** or **▲DIR** to scroll to **Settings**, then press **MENU/SELECT**.
3. Press **MENU/SELECT** to choose **LCD language**.
4. Press **▼CID** or **▲DIR** to highlight **English**, **Français** or **Español**, then press **MENU/SELECT**. The screen prompts **Set English/Français/Español as LCD language?**
5. Press **MENU/SELECT** to save your preference.



Note: If you accidentally change the LCD language to French or Spanish, you can reset it back to English without going through the French or Spanish menus. Press **MENU/SELECT** on the handset in idle mode, then enter **364#**. There is a confirmation tone.

Caller ID announce

The caller ID announce feature lets you know who's calling without having to look at the display.

To turn on or off the caller ID announce feature:

1. Press **MENU/SELECT** in idle mode to enter the main menu.
2. Press **▼CID** or **▲DIR** to scroll to **Settings**, then press **MENU/SELECT**.
3. Press **▼CID** or **▲DIR** to scroll to **Caller ID annc**, then press **MENU/SELECT**.
4. Press **▼CID** or **▲DIR** to highlight the desired option, then press **MENU/SELECT**.
 - ▶ **Set all On/Off** - Change the setting for the base and all handsets.
 - ▶ **Local handset** - Change the setting for that handset only.
 - ▶ **Base** - Change the setting for the telephone base only.
5. Press **▼CID** or **▲DIR** to highlight **On** or **Off**, then press **MENU/SELECT**.



Notes:

- ▶ To use the caller ID announce feature, you must subscribe to caller ID service from your telephone service provider.
- ▶ If you have paired an AT&T **TL80133** DECT 6.0 cordless speakerphone to the telephone base, the caller ID announce setting for all devices also applies to the speakerphone.
- ▶ Pronunciation of names may vary with this feature. Not all names may be pronounced correctly.

Handset settings

Set speed dial voicemail number

This feature lets you save your voicemail number for quick access when you press and hold the  **1** key.

To save your voicemail number:

1. Press **MENU/SELECT** in idle mode to enter the main menu.
2. Press **▼CID** or **▲DIR** to scroll to **Settings**, then press **MENU/SELECT**.
3. Press **▼CID** or **▲DIR** to scroll to **Voicemail #**, then press **MENU/SELECT**.
4. Use the dialing keys to enter the voicemail access number provided by your telephone service provider (up to 30 digits) when prompted.
 - ▶ Press **▼CID** or **▲DIR** to move the cursor to the left or right.
 - ▶ Press **MUTE/DELETE** on the handset to erase a digit.
 - ▶ Press and hold **MUTE/DELETE** on the handset to erase all digits.
 - ▶ Press **REDIAL/PAUSE** to enter a three-second dialing pause (a **p** appears).
5. Press **MENU/SELECT** to save.

Voicemail (visual message waiting) indicator

If you subscribe to a voicemail service, New voicemail and the  icon appear on the handset screen when you have new voicemail messages. Contact your service provider for more information and assistance about using your voicemail service.

Handset settings

Clear voicemail indication

Use this feature when the telephone indicates there is new voicemail but there is none. For example, when you have accessed your voicemail while away from home. This feature only turns off the displayed New voicemail and the  icon; it does not delete your voicemail messages. As long as you have new voicemail messages, your telephone service provider continues to send the signal to turn on the indicators.

To manually turn off the new voicemail indicators:

1. Press **MENU/SELECT** when in idle mode to enter the main menu.
2. Press **▼CID** or **▲DIR** to scroll to **Settings**, then press **MENU/SELECT**.
3. Press **▼CID** or **▲DIR** to scroll to **Clr voicemail**, then press **MENU/SELECT**.
The screen shows **Reset Voicemail Indicator?**.
4. Press **MENU/SELECT** again to turn the voicemail indication off.



Note: For information about using your voicemail service, contact your telephone service provider.

Key tone

The handset is set to beep with each key press. You can adjust the key tone volume or turn it off.

1. Press **MENU/SELECT** in idle mode to enter the main menu.
2. Press **▼CID** or **▲DIR** to scroll to **Settings**, then press **MENU/SELECT**.
3. Press **▼CID** or **▲DIR** to scroll to **Key tone**, then press **MENU/SELECT**.
4. Press **▼CID** or **▲DIR** to select the desired volume or **Off**.
5. Press **MENU/SELECT** to save your preference.

Handset settings

Home area code

If you dial seven digits to make a local call (no area code required), enter your area code into the telephone as the home area code. When you receive a call from within your home area code, the caller ID log only displays the seven digits of the telephone number.

This feature makes it easy for you to place a call from the caller ID log. If you dial ten digits to make a local phone call, do not use this home area code feature. If you do, you cannot place local calls from your caller ID log, as they will have only seven digits.

To set the home area code:

1. Press **MENU/SELECT** in idle mode to enter the main menu.
2. Press **▼CID** or **▲DIR** to scroll to **Settings**, then press **MENU/SELECT**.
3. Press **▼CID** or **▲DIR** to scroll to **Home area code**, then press **MENU/SELECT**.
The screen briefly shows **Only for 7 digit dial from CID**.
4. Use the dialing keys to enter a three-digit home area code.
 - Press **MUTE/DELETE** to delete a digit.
 - Press and hold **MUTE/DELETE** to delete all digits.
5. Press **MENU/SELECT** to save.



Note: If in the future, your telephone service provider requires you to dial ten digits to make a local call (area code plus telephone number), you need to delete your home area code and dial out locally from the call ID log. With the home area code displayed, press and hold **MUTE/DELETE** until the digits are deleted, and then press **MENU/SELECT**. The home area code is now restored to its default setting of **_ _ _** (empty).

Dial mode

The dial mode is preset to tone dialing. If you have pulse (rotary) service, you must change the dial mode to pulse dialing before using the telephone.

To set the dial mode:

1. Press **MENU/SELECT** in idle mode to enter the main menu.
2. Press **▼CID** or **▲DIR** to scroll to **Settings**, then press **MENU/SELECT**.
3. Press **▼CID** or **▲DIR** to scroll to **Dial mode**, then press **MENU/SELECT**.
4. Press **▼CID** or **▲DIR** to scroll to **Touch-tone** or **Pulse**, then press **MENU/SELECT**.

Handset settings

QUIET mode

When QUIET mode is turned on, the telephone silences all sounds during the set period of time (1-12 hours). However, the handset locator paging tone and any sound-generating operations initiated by users, such as making calls using the speakerphone or setting ringer volume, will sound as normal. After you turn on QUIET mode, this feature activates immediately and the answering system turns on automatically. When QUIET mode is on, the answering system takes calls and records messages without broadcasting them.

To turn QUIET mode on:

1. Press and hold QUIET # in idle mode to enter the **QUIET** mode setting screen. The screen shows **Quiet: __ hours (1-12 hours)**.
2. Use the dialing keys to enter the desired number of hours (1-12) you would like to turn on **QUIET** mode, then press **MENU/SELECT**. Your screen briefly shows **Answering sys is ON**, and then **Quiet mode on**.

To turn QUIET mode off:

- ▶ While **QUIET** mode is on, press and hold QUIET #. Then, the screen shows **Quiet mode is off** and you hear a confirmation tone.



Notes:

- ▶ If you change the base ringer, handset ringer, ringer volume, key tone, or caller ID announce features when QUIET mode is on, the sample plays but the feature is still muted after saving the setting.
- ▶ After QUIET mode is turned off or the set period of time has expired, all muted features will be activated again.
- ▶ The PTT function is not available when QUIET mode is on.
- ▶ Intercom is available during QUIET mode, but the handset will not ring.
- ▶ When QUIET mode is on, and Smart call blocker is on and in screening mode, all screened calls will be sent to the answering system after screening. For more information on Smart call blocker, see page 81.

Telephone base settings

Use the menu to change the telephone settings.

1. Press **MENU/SELECT** on the telephone base when it is not in use to enter the main menu.
2. Press **▼CID** or **▲DIR** to scroll to the feature to be changed. When scrolling through the menu, the **>** symbol indicates the selected menu item.
3. Press **MENU/SELECT** to select the highlighted item.

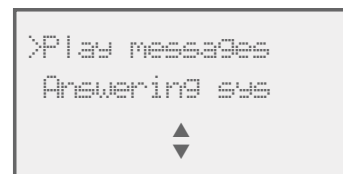

Note: Press **CANCEL** to cancel an operation, back up to the previous menu or exit the menu display. Press and hold CANCEL to return to idle mode.

Ringer volume

You can set the ringer volume level to one of the six levels or turn the ringer off. When the ringer is off,  appears on the screen.

1. Press **MENU/SELECT** in idle mode to enter the main menu.
2. Press **▼CID** or **▲DIR** to scroll to **Ringers**, then press **MENU/SELECT**.
3. Press **MENU/SELECT** again to select **Ringer volume**.
4. Press **▼CID** or **▲DIR** to sample each volume level.
5. Press **MENU/SELECT** to save your preference.



Note: The telephone base ringer volume also determines the ringer volume for intercom calls.

Ringer tone

You can choose one of the ten ringer tones.

1. Press **MENU/SELECT** in idle mode to enter the main menu.
2. Press **▼CID** or **▲DIR** to scroll to **Ringers**, then press **MENU/SELECT**.
3. Press **▼CID** or **▲DIR** to scroll to **Ringer tone**, then press **MENU/SELECT**.
4. Press **▼CID** or **▲DIR** to sample each ringer tone.
5. Press **MENU/SELECT** to save your preference.



Note: If you turn off the ringer volume, you will not hear ringer tone samples.

Telephone base settings

Set date/time

The answering system announces the day and time of each message prior to playing it. Before using the answering system, set the date and time as follows. If you subscribe to caller ID service, the day, month and time are set automatically with each incoming call. The year must be set so that the day of the week can be calculated from the caller ID information.

1. When the telephone base is in idle mode, press **MENU/SELECT** to enter the main menu.
2. Press **▼CID** or **▲DIR** to scroll to **Set date/time**, then press **MENU/SELECT**.
3. Press **▼CID** or **▲DIR** to select the month, then press **MENU/SELECT**, or enter the number using the dialing keys.
4. Press **▼CID** or **▲DIR** to select the day, then press **MENU/SELECT**, or enter the number using the dialing keys.
5. Press **▼CID** or **▲DIR** to select the year, or enter the number using the dialing keys, then press **MENU/SELECT** to move on to set the time.
6. Press **▼CID** or **▲DIR** to select the hour, then press **MENU/SELECT**, or enter the number using the dialing keys.
7. Press **▼CID** or **▲DIR** to select the minute, then press **MENU/SELECT**, or enter the number using the dialing keys.
8. Press **▼CID** or **▲DIR** to select **AM** or **PM**, or press **2** for **AM** or **7** for **PM**. Press **MENU/SELECT** to confirm.



Note: If the clock is not set when a message is recorded, the system announces, “*Time and day not set,*” before it plays the message.

Telephone base settings

LCD language

You can select the language used for all screen displays.

1. Press **MENU/SELECT** in idle mode to enter the main menu.
2. Press **▼CID** or **▲DIR** to scroll to **Settings**, then press **MENU/SELECT**.
3. Press **MENU/SELECT** to choose **LCD language**.
4. Press **▼CID** or **▲DIR** to highlight **English, Français** or **Español**, then press **MENU/SELECT**. The screen prompts **Set English/Français/Español as LCD language?**.
5. Press **MENU/SELECT** to confirm and save your preference.



Note: If you accidentally change the LCD language to French or Spanish, you can reset it back to English without going through the French or Spanish menus. Press **MENU/SELECT** on the base in idle mode, then enter **364#**. There is a confirmation tone.

Caller ID announce

The caller ID announce feature lets you know who's calling without having to look at the display.

To turn on or off the caller ID announce feature:

1. Press **MENU/SELECT** in idle mode to enter the main menu.
2. Press **▼CID** or **▲DIR** to scroll to **Settings**, then press **MENU/SELECT**.
3. Press **▼CID** or **▲DIR** to scroll to **Caller ID annc**, then press **MENU/SELECT**.
4. Press **▼CID** or **▲DIR** to highlight the desired option, then press **MENU/SELECT**.
 - ▶ **Set all On/Off** - Change the setting for the base and all handsets.
 - ▶ **Base** - Change the setting for the telephone base only.
5. Press **▼CID** or **▲DIR** to highlight **On** or **Off**, then press **MENU/SELECT**.



Notes:

- ▶ To use the caller ID announce feature, you must subscribe to caller ID service from your telephone service provider.
- ▶ If you have paired an AT&T **TL80133** DECT 6.0 cordless speakerphone to the telephone base, the caller ID announce setting for all devices also applies to the speakerphone.
- ▶ Pronunciation of names may vary with this feature. Not all names may be pronounced correctly.

Telephone base settings

Set speed dial voicemail number

This feature lets you save your voicemail number for easy access when you press and hold the  **1** key.

To save your voicemail number:

1. Press **MENU/SELECT** in idle mode to enter the main menu.
2. Press **▼CID** or **▲DIR** to scroll to **Settings**, then press **MENU/SELECT**.
3. Press **▼CID** or **▲DIR** to scroll to **Voicemail #**, then press **MENU/SELECT**.
4. Use the dialing keys to enter the voicemail access number provided by your telephone service provider (up to 30 digits) when prompted.
 - ▶ Press **▼CID** or **▲DIR** to move the cursor to the left or right.
 - ▶ Press **MUTE/DELETE** on the telephone base to erase a digit.
 - ▶ Press and hold **MUTE/DELETE** on the telephone base to erase all digits.
 - ▶ Press **REDIAL/PAUSE** to enter a three-second dialing pause (a **p** appears).
5. Press **MENU/SELECT** to save.

Voicemail (visual message waiting) indicator

If you subscribe to a voicemail service offered by your telephone service provider, New voicemail and the  icon appear on the telephone base screen when you have new messages. Contact your service provider for more information and assistance about using your voicemail service.

Telephone base settings

Clear voicemail indication

Use this feature when the telephone indicates there is new voicemail but there is none. For example, when you have accessed your voicemail while away from home. This feature only turns off the displayed **New voicemail** and the  icon; it does not delete your voicemail messages. As long as you have new voicemail messages, your telephone service provider continues to send the signal to turn on the indicators.

To manually turn off the new voicemail indicators:

1. Press **MENU/SELECT** when in idle mode to enter the main menu.
2. Press **▼CID** or **▲DIR** to scroll to **Settings**, then press **MENU/SELECT**.
3. Press **▼CID** or **▲DIR** to scroll to **Clr voicemail**, then press **MENU/SELECT**.
The screen shows **Reset Voicemail Indicator?**.
4. Press **MENU/SELECT** again to turn the voicemail indication off.



Note: For information about using your voicemail service, contact your telephone service provider.

Key tone

The telephone base is set to beep with each key press. You can adjust the key tone volume or turn it off.

1. Press **MENU/SELECT** in idle mode to enter the main menu.
2. Press **▼CID** or **▲DIR** to scroll to **Settings**, then press **MENU/SELECT**.
3. Press **▼CID** or **▲DIR** to scroll to **Key tone**, then press **MENU/SELECT**.
4. Press **▼CID** or **▲DIR** to select the desired volume or **Off**.
5. Press **MENU/SELECT** to save your preference.

Telephone base settings

Home area code

If you dial seven digits to make a local call (no area code required), enter your area code into the telephone as the home area code. When you receive a call from within your home area code, the caller ID log only displays the seven digits of the telephone number.

This feature makes it easy for you to place a call from the caller ID log. If you dial 10 digits to make a local phone call, do not use this home area code feature. If you do, you cannot place local calls from your caller ID log, as they will have only seven digits.

To set the home area code:

1. Press **MENU/SELECT** in idle mode to enter the main menu.
2. Press **▼CID** or **▲DIR** to scroll to **Settings**, then press **MENU/SELECT**.
3. Press **▼CID** or **▲DIR** to scroll to **Home area code**, then press **MENU/SELECT**.
The screen briefly shows **Only for 7 digit dial from CID**.
4. Use the dialing keys to enter a three-digit home area code.
 - Press **MUTE/DELETE** to delete a digit.
 - Press and hold **MUTE/DELETE** to delete all digits.
5. Press **MENU/SELECT** to save.



Note: If in the future, your telephone service provider requires you to dial ten digits to make a local call (area code plus telephone number), you need to delete your home area code and dial out locally from the caller ID log. With the home area code displayed, press and hold **MUTE/DELETE** until the digits are deleted, and then press **MENU/SELECT**. The home area code is now restored to its default setting of **__** (empty).

Dial mode

The dial mode is preset to tone dialing. If you have pulse (rotary) service, you must change the dial mode to pulse dialing before using the telephone.

To set the dial mode:

1. Press **MENU/SELECT** in idle mode to enter the main menu.
2. Press **▼CID** or **▲DIR** to scroll to **Settings**, then press **MENU/SELECT**.
3. Press **▼CID** or **▲DIR** to scroll to **Dial mode**, then press **MENU/SELECT**.
4. Press **▼CID** or **▲DIR** to highlight **Touch-tone** or **Pulse**, then press **MENU/SELECT**.

Telephone operation

Making a call

Using a cordless handset:

- ▶ Press **PHONE/FLASH** or **SPEAKER**, then enter the telephone number.

Using the telephone base:

- ▶ Press **SPEAKER**, then enter the telephone number.

Answering a call

Using a cordless handset:

- ▶ Press **PHONE/FLASH** or **SPEAKER**.
- OR-
- ▶ Press any dialing key (**0-9**, **TONE X** or **#**).

Using the telephone base:

- ▶ Press **SPEAKER**.
- OR-
- ▶ Press any dialing key (**0-9**, **TONE X** or **#**).

Ending a call

Using a cordless handset:

- ▶ Press **OFF/CANCEL** or return the handset to the telephone base or charger.

Using the telephone base:

- ▶ Press **SPEAKER**.

Handset speakerphone

During a call, press **SPEAKER** to switch between handsfree speakerphone and normal handset use. Press **OFF/CANCEL** to hang up.

 Note: The speakerphone uses more power than the normal handset. If the handset battery becomes very low while you are using the speakerphone, the call remains in speakerphone mode until you hang up or the battery becomes depleted.

Telephone operation

Last number redial

Each handset and the telephone base stores the last ten telephone numbers dialed (up to 30 digits each).

Using a cordless handset:

- Press **REDIAL/PAUSE**, then **▼CID**, **▲DIR** or **REDIAL/PAUSE** repeatedly to view up to ten recently called numbers. Press **PHONE/FLASH** or **📞/SPEAKER** to dial the displayed number.

Using the telephone base:

- Press **REDIAL/PAUSE**, then **▼CID**, **▲DIR** or **REDIAL/PAUSE** repeatedly to view up to 10 recently called numbers. Press **📞/SPEAKER** to dial the displayed number.

Equalizer

The equalizer feature enables you to change the quality of the audio to best suit your hearing.

Using a cordless handset or the telephone base:

1. While on a call or intercom call, press **MENU/SELECT**.
2. Press **MENU/SELECT** to select **Equalizer**.
3. Press **▼CID** or **▲DIR** to select **Treble 1**, **Treble 2**, **Bass** or **Natural** (the default setting). The current setting is shown on the screen for two seconds.

Volume control

Using a cordless handset:

You can set the listening volume to one of six levels. While on a call, press **VOL ▼CID** to decrease or press **VOL ▲DIR** to increase the listening volume.

Using the telephone base:

You can set the listening volume to one of eight levels. While on a call, press **▼/VOL** to decrease or **▲/VOL** to increase the listening volume.

Telephone operation

Call waiting

If you subscribe to call waiting service from your telephone service provider, and someone calls while you are already on a call, you hear two beeps.

- ▶ Press **\PHONE/FLASH** on the handset or **PTT/FLASH** on the telephone base to put your current call on hold and take the new call.
- ▶ Press **\PHONE/FLASH** on your handset or **PTT/FLASH** on your telephone base at any time to switch back and forth between calls.

Mute

Use the mute function to turn off the microphone. You can hear the caller, but the caller cannot hear you.

Using a cordless handset:

- ▶ Press **MUTE/DELETE** while on a call to enable or disable the mute feature.

Using the telephone base:

- ▶ Press **MUTE** while on a call to enable or disable the mute feature.

Options while on calls

Chain dialing

Use this feature to initiate a dialing sequence from the numbers in the directory, caller ID log or redial memory while you are on a call.

Using a cordless handset:

To access the directory or caller ID log while on a call:

1. Press **MENU/SELECT**.
2. Press **▼CID** or **▲DIR** to scroll to **Directory** or **Caller ID log**, then press **MENU/SELECT**.
3. Press **▼CID** or **▲DIR** to scroll to the desired number.
4. Press **MENU/SELECT** to dial the number shown.

To access the redial list while on a call:

1. Press **REDIAL/PAUSE** to show the most recently dialed number.
2. Press **▼CID** or **▲DIR** to scroll to the desired number, or press **REDIAL/PAUSE** repeatedly to find the desired number. Press **MENU/SELECT** to dial the number shown.

Using the telephone base:

To access the directory or caller ID log while on a call:

1. Press **MENU/SELECT**.
2. Press **▼CID** or **▲DIR** to scroll to **Directory** or **Caller ID log**, then press **MENU/SELECT**.
3. Press **▼CID** or **▲DIR** to scroll to the desired number.
4. Press **MENU/SELECT** to dial the number shown.

To access the redial list while on a call:

1. Press **REDIAL/PAUSE** to show the most recently dialed number.
2. Press **▼CID** or **▲DIR** to scroll to the desired number, or press **REDIAL/PAUSE** repeatedly to find the desired number. Press **MENU/SELECT** to dial the number shown.

Options while on calls

Blind transfer

While on an outside call, you can transfer the call to a specific device or any device without notifying them.

To transfer an outside call from a cordless handset:

1. During the call, press **MENU/SELECT**.
2. Press **▼CID** or **▲DIR** to scroll **Transfer**, then press **MENU/SELECT**.
 - ▶ If you have one handset and no other registered devices, the outside call is put on hold and your handset shows **Transferring call...** The telephone base rings and shows **Transfer from HANDSET X**.
 - ▶ If you have other registered device(s) or more than one handset, your screen shows **TRANSFER TO:**. Use the dialing keys to enter a specific device number (**0** for the telephone base, **1-9** for handsets 1-9, **TONEX** followed by **0-2** for handsets 10-12, or **TONEX** followed by **#** for all devices), or press **▼CID** or **▲DIR** to scroll to the desired device and press **MENU/SELECT**. The outside call is put on hold and your handset screen shows **Transferring call...** or **Transferring call to all...** The other device rings and shows **Transfer from HANDSET X (HANDSET** represents the handset name, **X** represents the handset number).
3. To answer the call on the destination handset, press **\PHONE/FLASH** or **🔊/SPEAKER**. To answer the call on the telephone base, press **🔊/SPEAKER**. The initiating handset shows **Call transferred** and goes to idle mode.

To transfer an outside call from the telephone base:

1. During the call, press **MENU/SELECT**.
2. Press **▼CID** or **▲DIR** to scroll **Transfer**, then press **MENU/SELECT**.
 - ▶ If you have one handset and no other registered devices, the outside call is put on hold and the telephone base shows **Transferring call...** The handset rings and shows **Transfer from BASE 0 (BASE** represents the base name).

Options while on calls

- ▶ If you have other registered device(s) or more than one handset, the telephone base shows **TRANSFER TO:**. Use the dialing keys to enter a specific handset number (**1-9** for handsets 1-9, **TONEX** followed by **0-2** for handsets 10-12, or **TONEX** followed by **#** for all devices), or press **▼CID** or **▲DIR** to scroll to the desired device and press **MENU/SELECT**. The outside call is put on hold and the telephone base shows **Transferring call...** or **Transferring call to all...**. The other handset(s) rings and shows **Transfer from BASE 0** (**BASE** represents the base name).
- 3. To answer the call on the destination handset, press **\PHONE/FLASH** or **🔊/SPEAKER**. The telephone base shows **Call transferred** and goes to idle mode.

Multiple handset use

Handset locator

The handset locator feature is useful if you misplace any handsets.



To start the paging tone:

- ▶ Press /**FIND HS** on the telephone base to start the paging tone on all handsets for 60 seconds.



Note: If you press /**OFF/CANCEL** or **MUTE/DELETE** on handset, the ringer of that handset stops, but the paging to the rest of the handsets continues.

To stop the paging tone:

- ▶ Press **PHONE/FLASH**, /**SPEAKER**, or any dialing key (**0-9**, **TONE X** or **#**) on the handset(s).
- OR-
- ▶ Press /**FIND HS**, **MUTE** or **CANCEL** on the telephone base.

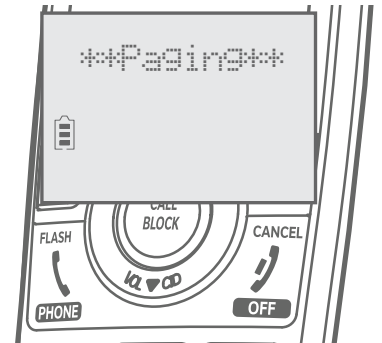
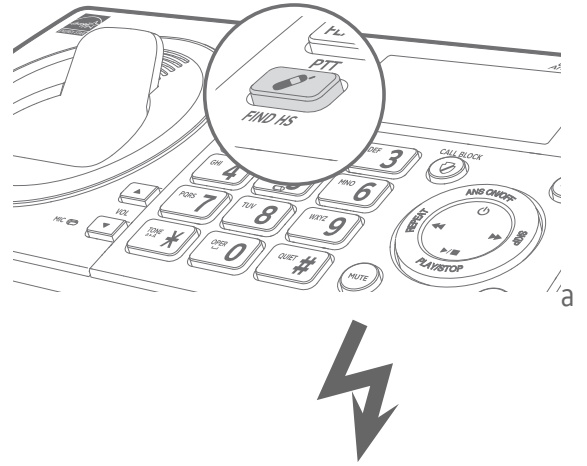

Intercom

Use the intercom feature for conversations between two handsets, a handset and the telephone base, or a handset/telephone base and a cordless headset/speakerphone (sold separately). You can buy additional expansion handsets (model AT&T CL80119), cordless headsets and speakerphones for this telephone base to expand your telephone system (up to 12 handsets or 10 cordless handsets and two cordless headsets/speakerphones).

Using a cordless handset:

1. Press **MENU/SELECT** in idle mode to enter the main menu. Press **▼CID** or **▲DIR** to scroll to **Intercom**, then press **MENU/SELECT**.
 - If you have one handset and no other registered devices, the handset shows **Calling base**.
 - If you have cordless headset(s)/speakerphone(s) or more than one handset, the handset shows **INTERCOM TO:**. Use the dialing keys to enter a specific device number (**0** for the telephone base, **1-9** for handsets 1-9, **TONEX** followed by **0-2** for handsets 10-12, **#** for a single headset/speakerphone, **#** followed by **1** or **2** for headset/speakerphone 1 or 2, or **TONEX** followed by **#** for all devices), or press **▼CID** or **▲DIR** to scroll to the desired device and press **MENU/SELECT**. Your handset screen shows **Calling HANDSET X**, **Calling BASE 0**, **Calling headset** or **Calling all devices**.

The destination device(s) rings and shows **HANDSET X is calling** or **HANDSET X is calling all** (**HANDSET** represents the handset name, **X** represents the handset number).
2. To answer the intercom call, press **\PHONE/FLASH, ◀/SPEAKER** or any dialing key (**0-9**, **TONEX**, or **#**) on the called device. Both devices now show **Intercom**.
3. To end the intercom call, one party presses **∕OFF/CANCEL**, or places the handset back in the telephone base or charger; or presses **CANCEL** on the telephone base. The other party hears four beeps. Both devices display **Intercom ended**.

Intercom

Using the telephone base:

1. When the telephone base is not in use, press **MENU/SELECT** to enter the main menu. Press **▼CID** or **▲DIR** to scroll to **Intercom**, then press **MENU/SELECT**.
 - ▶ If you have one handset and no other registered devices, the telephone base shows **Calling HANDSET X**.
 - ▶ If you have cordless headset(s)/speakerphone(s) or more than one handset, the telephone base shows **INTERCOM TO:**. Use the dialing keys to enter a specific handset number (**1-9** for handsets 1-9, **TONEX** followed by **0-2** for handsets 10-12, **#** for a single headset/speakerphone, **#** followed by **1** or **2** for headset/speakerphone 1 or 2, or **TONEX** followed by **#** for all devices), or press **▼CID** or **▲DIR** to scroll to the desired device and press **MENU/SELECT**. The telephone base shows **Calling HANDSET X** or **Calling all handsets**.

The destination device(s) rings and shows **BASE 0 is calling** or **BASE 0 is calling all**.

2. To answer the intercom call, press **\PHONE/FLASH, ◀/SPEAKER** or any dialing key (**0-9, TONEX, or #**) on the destination handset. Both the base and the handset now show **Intercom**.
3. To end the intercom call, one party presses **!OFF/CANCEL**, or places the handset back in the telephone base or charger; or presses **CANCEL** on the telephone base. The other party hears four beeps. Both devices display **Intercom ended**.



Notes:

- ▶ For cordless headsets and speakerphones, refer to the corresponding user's manual on how to answer and end an intercom call.
- ▶ If a total of two cordless headset(s) and/or speakerphone(s) are registered to the telephone base, they appear as **HEADSET 1** and **HEADSET 2**, respectively, in the intercom menu.

Push-to-talk (PTT)

You can directly broadcast messages to the speakerphone of any device. Press and hold **PTT** on a handset or **PTT/FLASH** on the telephone base to begin two-way communication.

- ▶ Only one device can talk at a time. To do so, press and hold **PTT** on the handset or **PTT/FLASH** on the telephone base.
- ▶ You must release **PTT** on the handset or **PTT/FLASH** on the telephone base, so the other person can respond.
- ▶ Only one PTT session can be active at a time.
- ▶ While PTT is in use between two devices, other devices cannot use the intercom feature but can access the answering system.

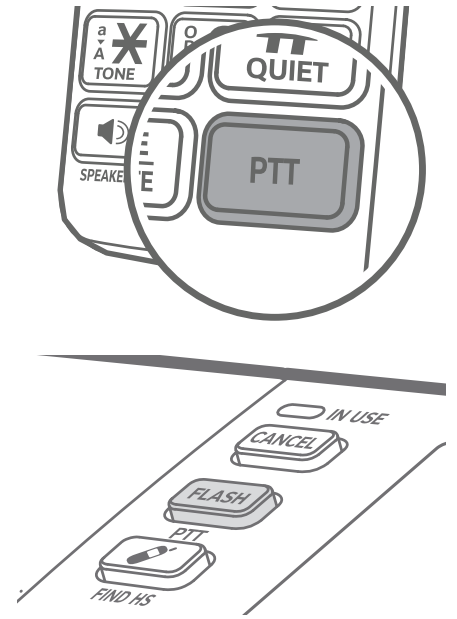

Turn PTT on or off

Using a cordless handset:

1. Press **PTT** when the handset is not in use. The **PUSH TO TALK** menu displays.
2. Press **▼CID** or **▲DIR** to choose **PTT On/Off**, then press **MENU/SELECT**.
3. Press **▼CID** or **▲DIR** to choose **On** or **Off**, then press **MENU/SELECT**.

Using the telephone base:

1. Press **PTT/FLASH** when the telephone base is not in use. The **PUSH TO TALK** menu displays.
2. Press **▼CID** or **▲DIR** to choose **PTT On/Off**, then press **MENU/SELECT**.
3. Press **▼CID** or **▲DIR** to choose **On** or **Off**, then press **MENU/SELECT**.

PTT call to a single device

Using a cordless handset:

1. There are a few ways to begin a PTT call to a single device. When the handset is not in use:
 - ▶ If you have one handset, press and hold **PTT**.
 - ▶ If you have more than one handset, press **PTT** on the handset. Press **▼CID** or **▲DIR** to choose the destination handset number and press **MENU/SELECT** or **PTT**.
2. Press and hold **PTT**.
3. Release **PTT** after speaking.
4. To end the PTT call, press **OFF/CANCEL** or place the handset in the telephone base or charger.

Push-to-talk (PTT)

Using the telephone base:

1. There are a few ways to begin a PTT call to a single handset. When the telephone base is not in use:
 - ▶ If you have one handset, press and hold **PTT/FLASH**.
 - ▶ If you have more than one handset, press **PTT/FLASH**. Use the dialing keys to enter the destination handset number.
2. Press and hold **PTT/FLASH**.
3. Release **PTT/FLASH** after speaking.
4. To end the PTT call, press **CANCEL**.

PTT call to multiple devices

When there are multiple handsets registered to the phone system, PTT supports one-to-group calls. PTT supports a maximum of one-to-five calls when one to five handsets are registered, and a maximum of one-to-four calls when six or more handsets are registered. The first four registered handsets will be able to use this feature. Other handsets can only use PTT for one-to-one calls.

Using a cordless handset:

1. Press and hold **PTT** until the handset shows **Connecting to group...** When the connection is made, both the caller and the destination parties hear a beep. The speakerphones on all other devices automatically activate.
2. You need to press and hold **PTT** when you want to speak. Speak towards the handset. Your voice is broadcast to all devices.
3. Release **PTT** after speaking.
4. Any device can reply (see **Answer a PTT call** on page 38).

Using the telephone base:

1. Press and hold **PTT/FLASH** until the screen shows **Connecting to group...** When the connection is made, both the caller and the destination parties hear a beep. The speakerphones on all other devices automatically activate.
2. You need to press and hold **PTT/FLASH** when you want to speak. Speak towards the telephone base. Your voice is broadcast to all devices.
3. Release **PTT/FLASH** after speaking.
4. Any handset can reply (see **Answer a PTT call** on page 38).

Push-to-talk (PTT)

Answer a PTT call

You can respond to a PTT call, as described below.

1. When your device receives a PTT call, it beeps and shows **Press and hold [PTT] to talk**.
2. When the other party is speaking, your speakerphone light is on, and your device shows:
 - **PTT From HS X To HS X** (the first **X** represents the initiating handset number, and the second **X** represents your handset number; a maximum of four handset numbers appear).
 - OR-
 - **PTT From HS X To Base & HS X** (the first **X** represents the initiating handset number, and the second **X** represents your handset number; a maximum of four handset numbers appear).
 - OR-
 - **PTT From Base To HS X** (the **X** represents your handset number; a maximum of five handset numbers appear).
3. When your speakerphone light is off (the screen shows **Press and hold [PTT] to talk**), press and hold **PTT** on your handset or **PTT/FLASH** on your telephone base. You will hear a chirp. Speak towards the device.
 - While you are speaking, your device shows **PTT To handset: X** (**X** represents the handset numbers of one or more destination handsets; a maximum of five handset numbers appear) or **PTT To base & handset: X** (**X** represents the handset numbers of one or more destination handsets; a maximum of four handset numbers appear).
 - Your voice is broadcast to all destination devices.

After speaking, release **PTT** on your handset or **PTT/FLASH** on your telephone base. Your device will beep. After the beep, if your speakerphone light is off, you can press and hold **PTT** on your handset or **PTT/FLASH** on your telephone base to continue speaking, or the destination device can respond.

Directory

The directory can store up to 50 entries, shared by all handsets and the telephone base.

Create a new directory entry

1. Press **MENU/SELECT** in idle mode to enter the main menu.
2. Scroll to select **Directory**, then scroll to select **Add contact**.
3. Use the dialing keys to enter a telephone number (up to 30 digits) when prompted.
 - ▶ Press **▼CID** or **▲DIR** to move the cursor to the left or right.
 - ▶ Press **MUTE/DELETE** on the handset or the telephone base to erase a digit.
 - ▶ Press and hold **MUTE/DELETE** on the handset or the telephone base to erase all digits.
 - ▶ Press and hold **REDIAL/PAUSE** to enter a three-second dialing pause (a **p** appears).

-OR-

Copy a number from the redial list by pressing **REDIAL/PAUSE**, then **▼CID**, **▲DIR**, or pressing **REDIAL/PAUSE** repeatedly to locate the number. Press **MENU/SELECT** to copy the number.

4. Press **MENU/SELECT** to move on to the name.
5. Use the dialing keys to enter a name (up to 15 characters) when prompted. Press a key repeatedly until the desired character shows on the screen.
 - ▶ Press **▼CID** or **▲DIR** to move the cursor to the left or right.
 - ▶ Press **0** to add a space.
 - ▶ Press **MUTE/DELETE** on the handset or the telephone base to erase a character.
 - ▶ Press and hold **MUTE/DELETE** on the handset or the telephone base to erase all characters.
 - ▶ Press **TONE X** to change the next letter to upper or lower case.
6. Press **MENU/SELECT** to store your new directory entry.

Review the directory

Review directory entries

Press **▲DIR** when in idle mode. Press **▼CID** or **▲DIR** to browse through the directory.

Search by name

1. Press **▲DIR** in idle mode to show the first listing in the directory.
2. When an entry appears, press the dialing keys (**0-9**) to start a name search. The directory shows the first name beginning with the first letter associated with the dialing key, if there is an entry in the directory beginning with that letter. Press **▼CID** or **▲DIR** to scroll through the directory.
3. To see other names starting with the letters on the same dialing key, keep pressing the key. The names appear in alphabetical order.

Delete a directory entry

Using a cordless handset:

To delete the displayed directory entry, press **MUTE/DELETE**. Press **MENU/SELECT** to confirm. You cannot retrieve a deleted entry.

Using the telephone base:

To delete the displayed directory entry, press **MUTE/DELETE**. Press **MENU/SELECT** to confirm. You cannot retrieve a deleted entry.

Review the directory

Edit a directory entry

1. When a directory entry displays, press **MENU/SELECT**. The screen shows **EDIT NUMBER** along with the phone number to be edited. If you only want to edit the name, skip to Step 3.
2. To edit the number:
 - ▶ Use the dialing keys to enter digits.
 - ▶ Press **▼CID** or **▲DIR** to move the cursor to the left or right.
 - ▶ Press **MUTE/DELETE** on the handset or on the telephone base to erase a digit.
 - ▶ Press and hold **MUTE/DELETE** on the handset or on the telephone base to erase all digits.
 - ▶ Press and hold **REDIAL/PAUSE** to add a three-second dialing pause (a **p** appears).
3. Press **MENU/SELECT** to move on to the name. The screen shows **EDIT NAME** along with the name to be edited.
4. To edit the name:
 - ▶ Use the dialing keys to enter characters.
 - ▶ Press **▼CID** or **▲DIR** to move the cursor to the left or right.
 - ▶ Press **MUTE/DELETE** on the handset or on the telephone base to erase a character.
 - ▶ Press and hold **MUTE/DELETE** on your handset or on your telephone base to erase all characters.
5. Press **MENU/SELECT** to save the entry.

Speed dial

The telephone system has nine speed dial locations (**2-9, 0**) and a voicemail access location  **1** where you can store the telephone numbers you wish to dial more quickly. You can store up to 30 digits in each location. Speed dial assignments can only be selected from the existing directory entries. The voicemail access number must be manually entered. In the directory, speed dial locations are indicated by their number on the bottom right hand corner of the entry.

Assign a speed dial number

1. When the telephone is in idle mode, press **MENU/SELECT**.
2. Press **▼CID** or **▲DIR** to scroll to **Directory**. Press **MENU/SELECT**.
3. Press **▼CID** or **▲DIR** to scroll to **Speed dial**. Press **MENU/SELECT**.
4. Press **▼CID** or **▲DIR** to choose your desired speed dial location (**0** or **2-9**), then press **MENU/SELECT**. The screen briefly shows **Copy from Directory...**, then displays the directory list.
5. Press **▼CID** or **▲DIR** to scroll to the phone number you wish to assign to the selected speed dial location.
6. Press **MENU/SELECT** to save the setting and return to the previous menu. There is a confirmation tone and the screen returns to the speed dial list.

Assign your voicemail speed dial number

To assign your voicemail speed dial number to location  **1**, see page 17 or page 24.

Make a call using speed dial

When in idle mode, press and hold the dialing key (**0** or **2-9**) corresponding to the assigned location you wish to call.

Check your voicemail using speed dial

When in idle mode, press and hold  **1** to dial the voicemail number you have set. See page 17 or page 24 to set your voicemail speed dial number.

Caller ID

This product supports caller ID services offered by most telephone service providers. The telephone stores caller ID information for the last 50 incoming calls in the telephone base. This information is common to all handsets and the telephone base.

Missed (new) call indicator

When a handset or the telephone base is in idle mode and has new or missed calls, its screen shows **XX Missed calls**.

If you do not want to review the missed calls one by one, but still want to keep them in the caller ID log, you can press and hold **⏻/OFF/CANCEL** on the handset for four seconds when the handset is idle, or press and hold **CANCEL** on the telephone base for four seconds when the telephone base is idle.

Review the caller ID log

1. When the handset or the telephone base is in idle mode, press **▼CID** to review the caller ID log in reverse chronological order starting with the most recent call.
2. Press **▼CID** or **▲DIR** to scroll through the list.
3. Press **⏻/OFF/CANCEL** on the handset or **CANCEL** on the telephone base to exit the caller ID log.

View dialing options

While reviewing the caller ID log, press **#** (pound key) repeatedly to show different dialing options for local and long distance numbers before dialing or saving the telephone number in the directory.

Press **1** repeatedly if you need to add or remove 1 in front of the telephone number before dialing or saving it in the directory.

When the number is in the correct format for dialing, press **☎/PHONE/FLASH** or **🔊/SPEAKER** on the handset, or **🔊/SPEAKER** on the telephone base to call the number.

Caller ID

Dial a caller ID log entry

1. When in the caller ID log, press ▼ **CID** or ▲ **DIR** to browse.
2. Press \ **PHONE/FLASH** or ◀ **/SPEAKER** on the handset, or ◀ **/SPEAKER** on the telephone base to dial the displayed entry.

Save a caller ID log entry to the directory

1. When in the caller ID log, press ▼ **CID** or ▲ **DIR** to browse.
2. When the desired entry displays, press **MENU/SELECT**.
3. Press **MENU/SELECT** to choose **Directory**.
4. When the screen displays **EDIT NUMBER**, use the dialing keys to edit the number.
 - ▶ Press ▼ **CID** or ▲ **DIR** to move the cursor to the left or right.
 - ▶ Press **MUTE/DELETE** on the handset or the telephone base to backspace and erase a digit.
 - ▶ Press and hold **MUTE/DELETE** on the handset or the telephone base to erase the entire entry.
 - ▶ Press and hold **REDIAL/PAUSE** to insert a three-second dialing pause (a **p** appears).
5. Press **MENU/SELECT** to move to the name.
6. When the screen displays **EDIT NAME**, use the dialing keys to edit the name.
 - ▶ Press ▼ **CID** or ▲ **DIR** to move the cursor to the left or right.
 - ▶ Press **MUTE/DELETE** on the handset or the telephone base to erase a character.
 - ▶ Press and hold **MUTE/DELETE** on the handset or the telephone base to erase all characters.
 - ▶ Press **#** (pound key) to move the last word to the front. For example, **Johnson Charlie** becomes **Charlie Johnson** when you press **#** (pound key).
7. Press **MENU/SELECT** when done. The screen shows **Saved to directory**.

About Smart call blocker*

If you have subscribed to caller ID service, then you can use Smart call blocker to filter robocalls, telemarketing calls and unwanted calls for you, while allowing welcome calls to get through.

You can set up your lists of welcome callers and unwelcome callers. Smart call blocker allows calls from your welcome callers to get through, and it blocks calls from your unwelcome callers.

For other unknown calls, you can allow these calls, block these calls, or forward these calls to the answering system.

With some easy configurations, you can set to only filter robocalls by asking the callers to press the pound key (#) before the calls are put through to you.

You can also set Smart call blocker to screen incoming calls by asking the callers to record their names and press the pound key (#). After your caller completes the request, your telephone rings and announces the caller's name. You can then choose to block or answer the call, or you can forward the call to the answering system. If the caller does not respond or record his/her name, the call is blocked from ringing through. When you add your welcome callers to your allow list, they will bypass all screening and ring directly to your handsets.



Notes:

- ▶ Smart call blocker is on, once you install your telephone. It allows all incoming calls to get through and ring by default. You can change the Smart call blocker settings to screen incoming calls. For more details, see **Set profile** (page 49), **Control calls without numbers** (page 50) and **Control uncategorized calls** (page 51).
- ▶ With call screening active, Smart call blocker screens and filters all incoming calls from numbers or names that are not yet saved in your directory, allow list, block list, or star name list. You can easily add incoming phone numbers to your allow list and block list. This allows you to build up your lists of allowed and blocked numbers, and Smart call blocker will know how to deal with these calls when they come in again.
- ▶ To turn off Smart call blocker, see **Set Smart call blocker on/off** on page 49.

* Includes licenced Qalte™ technology.

Qalte™ is a trademark of Truecall Group Limited.

About Smart call blocker

Call categories

Calls are classified into four categories:

Welcome calls

Welcome calls are calls with telephone numbers saved in your allow list or directory, and not in your block list. Welcome calls also include calls with caller names saved in your star name list.



Note: There are many organizations like schools, medical offices, and pharmacies that use robocalls to communicate important information to you. Robocall uses an autodialer to deliver pre-recorded messages. By entering the name of the organizations into the star name list, it ensures these calls will ring through when you only know the caller names but not their numbers.

Unwelcome calls

Unwelcome calls are calls with telephone numbers saved in your block list, and you want to block their calls.

Calls without numbers

Calls without numbers are calls that are “out of area“ or with numbers set to “Private“.

Uncategorized calls

Uncategorized calls include calls with absent caller ID number, calls with numbers that are not in your directory, allow list, or block list, or calls with caller ID names that are not in your star name list.



Note: The allow list stores up to 200 entries, the block list stores up to 1,000 entries, and the star name list stores up to 10 names.

About Smart call blocker

Call controls

- ▶ Smart call blocker is set to on, and to allow all incoming calls by default. When Smart call blocker is on, the first ring of all incoming calls will be muted.
- ▶ If your directory, allow list, star name list and block list are empty when Smart call blocker is on, and you have set to screen calls, the telephone will screen all incoming calls and asks callers to announce their names or press the pound key (#).
- ▶ If Smart call blocker is off, all incoming calls ring, including numbers saved in the block list.
- ▶ If QUIET mode is on, and Smart call blocker is on and in screening mode, all screened calls will be sent to the answering system after screening.

Smart call blocker handles calls in the following ways:

Call category	Call control
Welcome callers	<p>Allow</p> <p>The telephone rings when there is an incoming call with number saved in your allow list or directory, but not in your block list. Robocalls with caller names saved in your star name list will also ring.</p>
Unwelcome callers	<p>Block</p> <p>The telephone does not ring when there is an incoming call with number saved in your block list, and the call will be rejected.</p>

About Smart call blocker

Call category	Call control
<p>Calls without numbers</p> <ul style="list-style-type: none"> You can set to screen, allow, or block all calls of this call category, or to send these calls to the answering system. Allow is the default setting. To change the setting, see Control calls without numbers on page 50. 	<p>Screening with caller name</p> <p>If you have selected this option, the telephone plays the screening announcement, and then asks the caller to say his/her name before the call rings on your telephone. You can then answer the call, and hear the caller's name announced. You can decide whether to accept or reject the call, or to forward the call to the answering system.</p> <p>Screening without caller name</p> <p>If you have selected this option, the telephone plays the screening announcement, and then asks the caller to press the pound key (#) before the call rings on your telephone. You can then answer the call.</p> <p>Allow (default settings)</p> <p>The telephone allows the calls to get through and ring. The caller's number will not be saved to the allow list.</p> <p>Answering system</p> <p>If you have selected this option, the telephone forwards the calls to the answering system without ringing.</p> <p>Block</p> <p>If you have selected this option, the telephone rejects the calls with block announcement without ringing. The caller's number will not be saved to the block list.</p>
<p>Uncategorized calls</p> <ul style="list-style-type: none"> You can set to screen, allow, or block all calls of this call category, or to send these calls to the answering system. Allow is the default setting. To change the setting, see Control uncategorized calls on page 51. 	

Call block settings

Set Smart call blocker on/off

The Smart call blocker feature is set to on by default.

Using a cordless handset or the telephone base:

1. Press **CALL BLOCK** when it is not in use, and then press **MENU/SELECT** to select **SCB On/Off**.

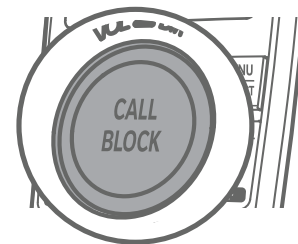

-OR-

Press **MENU/SELECT** to enter the main menu when it is not in use. Press **▼CID** or **▲DIR** to scroll to **Smart call blk**, then press **MENU/SELECT** twice.

2. Press **▼CID** or **▲DIR** to highlight **On** or **Off**, then press **MENU/SELECT** to save the setting. You hear a confirmation tone.



Note: If you set **SCB On/Off** to **Off**, all settings under **Set profile** (see below) will be invalid.

Set profile

There are six profile setting options, which allows you to quickly set up Smart call blocker.

1. Press **CALL BLOCK** on the handset when it is not in use.

-OR-

Press **MENU/SELECT** to enter the main menu when the handset is not in use. Press **▼CID** or **▲DIR** to scroll to **Smart call blk**, then press **MENU/SELECT**.

2. Press **▼CID** or **▲DIR** to scroll to **Set profile**, then press **MENU/SELECT**.
3. Press **▼CID** or **▲DIR** to select one of the following options, then press **MENU/SELECT**.

- ▶ **Screen unknown** - screen any calls from numbers not saved in the Directory, Allow list, or Star name list.
 - This profile setting sets the telephone to screen calls without numbers and uncategorized calls, and to ask the callers to say their names before putting the calls through to you. See **Screen calls without numbers** (page 64) and **Screen uncategorized calls** (page 67).
- ▶ **Screen w/o num** - screen calls that do not display a phone number.
 - This profile setting sets the telephone to screen calls without numbers and ask the callers to say their names before putting the calls through to you. It sets the telephone to allow all calls with numbers but the numbers are not in the Directory, Allow list, or Star name list.

Call block settings

- ▶ **Block only** (default setting) - allow all calls to ring, except calls with numbers on the **Block list**.
 - This profile setting sets the telephone to block calls with numbers found in the **Block list**.
- ▶ **Screen robot** - screen robocalls.
 - This profile setting sets the telephone to allow calls without numbers to get through and ring, but to screen uncategorized calls and ask the caller to press the pound key (#) before putting the call through to you.
- ▶ **UnknownToAns.S** - forward any calls from numbers not saved in the **Directory**, **Allow list**, or **Star name list** to the answering system.
 - This profile setting sets the telephone to forward all calls without numbers and uncategorized calls to the answering system.
- ▶ **Ring all calls** - allow all calls to ring and do not block any numbers.
 - This profile setting turns off the Smart call blocker, and allows all calls to get through and ring.
- ▶ **Customise** - manually set the call handling options for calls without numbers and uncategorized calls. See **Control calls without number** (see below) and **Control uncategorized calls** (page 51).



Note: If you set **SCB On/Off** to **Off**, all settings under **Set profile** will be invalid.

Control calls without numbers (Customized settings)

Use this setting to control “out of area” or “Private” calls. You can choose to allow or reject these calls directly. You can also choose to screen them with or without learning the callers’ names before you decide whether to answer or reject these calls. Moreover, you can forward these calls to the answering system.

To change the setting:

Using a cordless handset or the telephone base:

1. Press **CALL BLOCK** when it is not in use.
-OR-
Press **MENU/SELECT** to enter the main menu when it is not in use. Press **▼CID** or **▲DIR** to scroll to **Smart call blk**, then press **MENU/SELECT**.
2. Press **▼CID** or **▲DIR** to scroll to **Set profile**, then press **MENU/SELECT**.
3. Press **▼CID** or **▲DIR** to scroll to **Customise**, then press **MENU/SELECT**.
4. Press **MENU/SELECT** again to select **Calls w/o num**.

Call block settings

5. Press **▼CID** or **▲DIR** to choose one of the following options, then press **MENU/SELECT**.
 - **Screening** - ask the caller to press the pound key (**#**) or to say his/her name before the call rings on your telephone.
 - **Allow** - allow the calls to get through and ring.
 - **Answering sys** - forward the calls to the answering system without ringing.
 - **Block** - reject the calls with block announcement.
6. If you select **Screening**, press **▼CID** or **▲DIR** to choose one of the following options, then press **MENU/SELECT**.
 - **w/ Caller name** - ask the caller to say his/her name before the call rings on your telephone. You can then answer the call, and hear the caller's name announced. You can decide whether to answer or reject the call, or to forward the call to the answering system.
 - **w/o Caller name** - ask the caller to press the pound key (**#**) before the call rings on your telephone. You can then answer the call.

Control uncategorized calls (Customized settings)

Use this setting to control calls with numbers that are not in your directory, allow list or block list, or have no caller ID number display. You can choose to allow or reject these calls directly. You can also choose to screen them with or without learning the callers' names before you decide whether to answer or reject these calls. Moreover, you can forward these calls to the answering system.

To change the setting:

Using a cordless handset or the telephone base:

1. Press **CALL BLOCK** when it is not in use.
-OR-
Press **MENU/SELECT** to enter the main menu when it is not in use. Press **▼CID** or **▲DIR** to scroll to **Smart call blk**, then press **MENU/SELECT**.
2. Press **▼CID** or **▲DIR** to scroll to **Set profile**, then press **MENU/SELECT**.
3. Press **▼CID** or **▲DIR** to scroll to **Customise**, then press **MENU/SELECT**.
4. Press **▼CID** or **▲DIR** to scroll to **Uncategorized**, then press **MENU/SELECT**.

Call block settings

5. Press ▼**CID** or ▲**DIR** to choose one of the following options, then press **MENU/SELECT**.
 - ▶ **Screening** - ask the caller to press the pound key (#) or to say his/her name before the call rings on your telephone.
 - ▶ **Allow** - allow the calls to get through and ring.
 - ▶ **Answering sys** - send the calls to the answering system without ringing.
 - ▶ **Block** - reject the calls with block announcement.
6. If you select **Screening**, press ▼**CID** or ▲**DIR** to choose one of the following options, then press **MENU/SELECT**.
 - ▶ **w/ Caller name** - ask the caller to say his/her name before the call rings on your telephone. You can then answer the call, and hear the caller's name announced. You can decide whether to answer or reject the call, or to forward the call to the answering system.
 - ▶ **w/o Caller name** - ask the caller to press the pound key (#) before the call rings on your telephone. You can then answer the call.



Note: Robocalls will be classified as uncategorized calls. If you select **Screening**, the telephone screens and filters these calls. It asks the caller to press the pound key (#) or announces his/her name before putting the call through to you. There may be robocalls that you do not want to miss. For example, robocalls with announcements or notices from schools or pharmacies. You can set up your star name list with these caller names to allow their calls to get through to you. See **Star name list** on page 63.

Call block settings

Block list

Add numbers that you want to prevent their calls from ringing through. The block list stores up to 1,000 entries.

Add a block entry:

Using a cordless handset or the telephone base:

1. Press **CALL BLOCK** when it is not in use.
-OR-
Press **MENU/SELECT** to enter the main menu when it is not in use. Press **▼CID** or **▲DIR** to scroll to **Smart call blk**, then press **MENU/SELECT**.
2. Press **▼CID** or **▲DIR** to scroll to **Block list**, and then press **MENU/SELECT**.
3. Press **▼CID** or **▲DIR** to scroll to **Add new entry**, then press **MENU/SELECT**.
4. When the screen displays **ENTER NUMBER**, use the dialing keys to enter a number (up to 30 digits).
 - ▶ Press **▼CID** or **▲DIR** to move the cursor to the left or right.
 - ▶ Press **MUTE/DELETE** to erase a digit.
 - ▶ Press and hold **MUTE/DELETE** to erase all digits.
 - ▶ Press and hold **REDIAL/PAUSE** to enter a three-second dialing pause (a **p** appears).**-OR-**
Copy a number from the redial list by pressing **REDIAL/PAUSE**. Then, press **▼CID**, **▲DIR** or **REDIAL/PAUSE** repeatedly to find the desired number. Press **MENU/SELECT** to copy the number.
5. Press **MENU/SELECT** to move on to the name.
 - ▶ The screen shows **Number already saved** if the number is already in the block list. You cannot save the same number twice.

Call block settings

- When the screen displays **ENTER NAME**, use the dialing keys to enter a name (up to 15 characters). Press a key repeatedly until the desired character appears. The first character of every word is capitalized.
 - Press **▼CID** or **▲DIR** to move the cursor to the left or right.
 - Press **0** to add a space.
 - Press **MUTE/DELETE** to erase a character.
 - Press and hold **MUTE/DELETE** to erase all characters.
 - Press **-tone X** to change the next letter to upper or lower case.
- Press **MENU/SELECT** to store your block entry.



Notes:

- Numbers saved in your directory can also be saved to the block list.
- If you save a block list entry that has already been saved to the allow list, the entry in the allow list will be removed.

Review block list

- Press **CALL BLOCK** on the handset when it is not in use.
-OR-
Press **MENU/SELECT** to enter the main menu when the handset is not in use. Press **▼CID** or **▲DIR** to scroll to **Call block**, then press **MENU/SELECT**.
- Press **▼CID** or **▲DIR** to scroll to **Block list**, and then press **MENU/SELECT**.
- Press **MENU/SELECT** to choose **Review**.
- Press **▼CID** or **▲DIR** to browse through the call block entries.



Note: **Block list is empty** appears if there are no block entries.

Call block settings

Save a caller ID log entry to block list:

Using a cordless handset or the telephone base:

1. Search for the desired caller ID log entry (see **Review the caller ID log** on page 43).
2. When the desired entry displays, press **MENU/SELECT**.
3. Press **▼CID** or **▲DIR** to scroll to **Block list**, then press **MENU/SELECT**.
4. The handset displays **EDIT NUMBER**. Use the dialing keys to edit the number, when necessary.
 - ▶ Press **▼CID** or **▲DIR** to move the cursor to the left or right.
 - ▶ Press **MUTE/DELETE** to backspace and erase a digit.
 - ▶ Press and hold **MUTE/DELETE** to erase the entire entry.
 - ▶ Press and hold **REDIAL/PAUSE** to insert a three-second dialing pause (a **p** appears).
5. Press **MENU/SELECT** to move to the name. The screen displays **EDIT NAME**.
6. Use the dialing keys to add or edit the name.
 - ▶ Press **▼CID** or **▲DIR** to move the cursor to the left or right.
 - ▶ Press **0** to add a space.
 - ▶ Press **MUTE/DELETE** to erase a character.
 - ▶ Press and hold **MUTE/DELETE** to erase all characters.
 - ▶ Press **TONE X** to change the next letter to upper or lower case.
 - ▶ Press **#** (pound key) to move the last word to the front. For example, **Johnson Charlie** becomes **Charlie Johnson** when you press **#** (pound key).
7. Press **MENU/SELECT** when done and the screen shows **Saved to block list**.

Call block settings

Edit a block entry:

Using a cordless handset or the telephone base:

1. Search for the desired entry in the block list (see **Review block list** on page 54).
2. When the desired entry displays, press **MENU/SELECT**. The screen displays **EDIT NUMBER** along with the phone number to be edited. If you only want to edit the name, skip to Step 4.
3. To edit the number:
 - ▶ Use the dialing keys to enter digits.
 - ▶ Press **▼CID** or **▲DIR** to move the cursor to the left or right.
 - ▶ Press **MUTE/DELETE** to erase a digit.
 - ▶ Press and hold **MUTE/DELETE** to erase all digits.
 - ▶ Press and hold **REDIAL/PAUSE** to enter a three-second dialing pause (a **p** appears).
4. Press **MENU/SELECT** to move on to the name. The screen displays **EDIT NAME** along with the name to be edited.
5. To edit the name:
 - ▶ Use the dialing keys to enter characters.
 - ▶ Press **▼CID** or **▲DIR** to move the cursor to the left or right.
 - ▶ Press **0** to add a space.
 - ▶ Press **MUTE/DELETE** to erase a character.
 - ▶ Press and hold **MUTE/DELETE** to erase all characters.
6. Press **MENU/SELECT** to save the entry. The screen displays **Saved to block list**.

Call block settings

Delete a block entry:

1. Search for the desired entry in the block list (see **Review block list** on page 54).
2. When the desired entry displays, press **MUTE/DELETE** on the handset. The screen shows **Delete entry?**.
3. Press **MENU/SELECT** to confirm. The screen show **Entry deleted**, and the next entry displays. You cannot retrieve a deleted entry.



Note: If the call block list is empty after an entry is deleted, the screen displays **Block list is empty**.

Delete all block entries:

1. Press **CALL BLOCK** on the handset when it is not in use.
-OR-
Press **MENU/SELECT** to enter the main menu when the handset is not in use. Press **▼CID** or **▲DIR** to scroll to **Call block**, then press **MENU/SELECT**.
2. Press **▼CID** or **▲DIR** to scroll to **Block list**, and then press **MENU/SELECT**.
3. Press **▼CID** or **▲DIR** to highlight **Delete all**, then press **MENU/SELECT**. The screen shows **Delete all in block list?**.
4. Press **MENU/SELECT** again to confirm. The screen displays **Deleted**. There is a confirmation tone.

Call block settings

Allow list

Add numbers that you want to allow their calls to get through to you. The allow list stores up to 200 entries.

Add an allow entry:

Using a cordless handset or the telephone base:

1. Press **CALL BLOCK** when it is not in use.

-OR-

Press **MENU/SELECT** to enter the main menu when it is not in use. Press **▼CID** or **▲DIR** to scroll to **Smart call blk**, then press **MENU/SELECT**.

2. Press **▼CID** or **▲DIR** to scroll to **Allow list**, and then press **MENU/SELECT**.
3. Press **▼CID** or **▲DIR** to scroll to **Add new entry**, then press **MENU/SELECT**.
4. When the screen displays **ENTER NUMBER**, use the dialing keys to enter a number (up to 30 digits).
 - ▶ Press **▼CID** or **▲DIR** to move the cursor to the left or right.
 - ▶ Press **MUTE/DELETE** to erase a digit.
 - ▶ Press and hold **MUTE/DELETE** to erase all digits.
 - ▶ Press and hold **REDIAL/PAUSE** to enter a three-second dialing pause (a **p** appears).

-OR-

Copy a number from the redial list by pressing **REDIAL/PAUSE**. Then, press **▼CID**, **▲DIR** or **REDIAL/PAUSE** repeatedly to find the desired number. Press **MENU/SELECT** to copy the number.

5. Press **MENU/SELECT** to move on to the name.
 - ▶ The display shows **Number already saved** if the number is already in the allow list. You cannot save the same number twice.

Call block settings

6. When the screen displays **ENTER NAME**, use the dialing keys to enter a name (up to 15 characters). Press a key repeatedly until the desired character appears. The first character of every word is capitalized.
 - ▶ Press **▼CID** or **▲DIR** to move the cursor to the left or right.
 - ▶ Press **0** to add a space.
 - ▶ Press **MUTE/DELETE** to erase a character.
 - ▶ Press and hold **MUTE/DELETE** to erase all characters.
 - ▶ Press **-tone X** to change the next letter to upper or lower case.
7. Press **MENU/SELECT** to store your allow list entry.



Notes:

- ▶ Numbers saved in your directory can also be saved to the allow list.
- ▶ If you save an allow entry that has already been saved to the block list, the entry in the block list will be removed.

Review allow list:

Using a cordless handset or the telephone base:

1. Press **CALL BLOCK** when it is not in use.
-OR-
Press **MENU/SELECT** to enter the main menu when it is not in use. Press **▼CID** or **▲DIR** to scroll to **Smart call blk**, then press **MENU/SELECT**.
2. Press **▼CID** or **▲DIR** to scroll to **Allow list**, and then press **MENU/SELECT**.
3. Press **MENU/SELECT** to choose **Review**.
4. Press **▼CID** or **▲DIR** to browse through the allow entries.



Note: **Allow list is empty** appears if there are no allow entries.

Call block settings

Save a caller ID log entry to allow list:

Using a cordless handset or the telephone base:

1. Search for the desired caller ID log entry (see **Review the caller ID log** on page 43).
2. When the desired entry displays, press **MENU/SELECT**.
3. Press **▼CID** or **▲DIR** to scroll to **Allow list**, then press **MENU/SELECT**.
4. The handset displays **EDIT NUMBER**. Use the dialing keys to edit the number, when necessary.
 - ▶ Press **▼CID** or **▲DIR** to move the cursor to the left or right.
 - ▶ Press **MUTE/DELETE** on the handset to backspace and erase a digit.
 - ▶ Press and hold **MUTE/DELETE** to erase the entire entry.
 - ▶ Press and hold **REDIAL/PAUSE** to insert a three-second dialing pause (a **p** appears).
5. Press **MENU/SELECT** to move to the name. The screen displays **EDIT NAME**.
6. Use the dialing keys to add or edit the name.
 - ▶ Press **▼CID** or **▲DIR** to move the cursor to the left or right.
 - ▶ Press **0** to add a space.
 - ▶ Press **MUTE/DELETE** to erase a character.
 - ▶ Press and hold **MUTE/DELETE** to erase all characters.
 - ▶ Press **TONE ✕** to change the next letter to upper or lower case.
 - ▶ Press **#** (pound key) to move the last word to the front. For example, **Johnson Charlie** becomes **Charlie Johnson** when you press **#** (pound key).
7. Press **MENU/SELECT** when done and the screen shows **Saved to allow list**.

Call block settings

Edit an allow entry:

Using a cordless handset or the telephone base:

1. Search for the desired entry in the allow list (see **Review allow list** on page 59).
2. When the desired entry displays, press **MENU/SELECT**. The screen displays **EDIT NUMBER** along with the phone number to be edited. If you only want to edit the name, skip to Step 4.
3. To edit the number:
 - Use the dialing keys to enter digits.
 - Press **▼CID** or **▲DIR** to move the cursor to the left or right.
 - Press **MUTE/DELETE** on the handset to erase a digit.
 - Press and hold **MUTE/DELETE** to erase all digits.
 - Press and hold **REDIAL/PAUSE** to enter a three-second dialing pause (a **p** appears).
4. Press **MENU/SELECT** to move on to the name. The screen displays **EDIT NAME** along with the name to be edited.
5. To edit the name:
 - Use the dialing keys to enter characters.
 - Press **▼CID** or **▲DIR** to move the cursor to the left or right.
 - Press **0** to add a space.
 - Press **MUTE/DELETE** to erase a character.
 - Press and hold **MUTE/DELETE** to erase all characters.
6. Press **MENU/SELECT** to save the entry. The screen displays **Saved to allow list**.

Call block settings

Delete an allow entry:

Using a cordless handset or the telephone base:

1. Search for the desired entry in the allow list (see **Review allow list** on page 59).
2. When the desired entry displays, press **MUTE/DELETE** on the handset. The screen shows **Delete entry?**.
3. Press **MENU/SELECT** to confirm. The screen shows **Entry deleted**, and the next entry displays. You cannot retrieve a deleted entry.

Delete all allow list entries:

Using a cordless handset or the telephone base:

1. Press **CALL BLOCK** when it is not in use.
-OR-
Press **MENU/SELECT** to enter the main menu when it is not in use. Press **▼CID** or **▲DIR** to scroll to **Smart call blk**, then press **MENU/SELECT**.
2. Press **▼CID** or **▲DIR** to scroll to **Allow list**, and then press **MENU/SELECT**.
3. Press **▼CID** or **▲DIR** to highlight **Delete all**, then press **MENU/SELECT**. The screen shows **Delete all in allow list?**.
4. Press **MENU/SELECT** again to confirm. The screen displays **Deleted**. There is a confirmation tone.

Call block settings

Star name list

There are many organizations like schools, medical offices, and pharmacies that use robocalls to communicate important information to you. Robocall uses an autodialer to deliver pre-recorded messages. By entering the name of the organizations into the star name list, it ensures these calls will ring through when you only know the caller names but not their numbers.

If the first 15 characters of the incoming caller ID's name match a name saved in your star name list, the call will get through and ring. The star name list stores up to 10 names.

Add a star name entry:

Using a cordless handset or the telephone base:

1. Press **CALL BLOCK** when it is not in use.
-OR-
Press **MENU/SELECT** to enter the main menu when it is not in use. Press **▼CID** or **▲DIR** to scroll to **Smart call blk**, then press **MENU/SELECT**.
2. Press **▼CID** or **▲DIR** to scroll to **Star name list**, and then press **MENU/SELECT**.
3. Press **▼CID** or **▲DIR** to scroll to **Add new entry**, then press **MENU/SELECT**.
4. When the screen displays **ENTER NAME**, use the dialing keys to enter a name (up to 15 characters). Press a key repeatedly until the desired character appears. The first character of every word is capitalized.
 - ▶ Press **▼CID** or **▲DIR** to move the cursor to the left or right.
 - ▶ Press **0** to add a space.
 - ▶ Press **MUTE/DELETE** to erase a character.
 - ▶ Press and hold **MUTE/DELETE** to erase all characters.
 - ▶ Press **TONE X** to change the next letter to upper or lower case.
5. Press **MENU/SELECT** to store your star name entry. The display shows **Name already saved** if the name is already in the star name list. You cannot save the same name twice.

Call block settings

Review star name list:

Using a cordless handset or the telephone base:

1. Press **CALL BLOCK** when it is not in use.
-OR-
Press **MENU/SELECT** to enter the main menu when it is not in use. Press **▼CID** or **▲DIR** to scroll to **Smart call blk**, then press **MENU/SELECT**.
2. Press **▼CID** or **▲DIR** to scroll to **Star name list**, and then press **MENU/SELECT**.
3. Press **MENU/SELECT** to choose **Review**.
4. Press **▼CID** or **▲DIR** to browse through the star name entries.



Note: **Star name list is empty** appears if there are no star name entries.

Save a caller ID log entry to star name list:

Using a cordless handset or the telephone base:

1. Search for the desired caller ID log entry (see **Review the caller ID log** on page 43).
2. When the desired entry displays, press **MENU/SELECT**.
3. Press **▼CID** or **▲DIR** to scroll to **Star name list**, then press **MENU/SELECT**.
4. The handset displays **Star this name?**, and the caller ID name of the caller.
5. Press **MENU/SELECT**, and the screen shows **Saved to star name list**.

Call block settings

Edit a star name entry:

Using a cordless handset or the telephone base:

1. Search for the desired entry in the star name list (see **Review star name list** on page 64).
2. When the desired entry displays, press **MENU/SELECT**. The screen displays **EDIT NAME** along with the name to be edited.
3. To edit the name:
 - Use the dialing keys to enter characters.
 - Press **▼CID** or **▲DIR** to move the cursor to the left or right.
 - Press **0** to add a space.
 - Press **MUTE/DELETE** to erase a character.
 - Press and hold **MUTE/DELETE** to erase all characters.
4. Press **MENU/SELECT** to save the entry. The screen displays **Saved to star name list**.

Delete a star name entry:

1. Search for the desired entry in the star name list (see **Review star name list** on page 64).
2. When the desired entry displays, press **MUTE/DELETE** on the handset. The screen shows **Delete entry?**
3. Press **MENU/SELECT** to confirm. The screen show **Entry deleted**, and the next entry displays. You cannot retrieve a deleted entry.

Call block settings

Delete all star name entries:

Using a cordless handset or the telephone base:

1. Press **CALL BLOCK** when it is not in use.
-OR-
Press **MENU/SELECT** to enter the main menu when it is not in use. Press **▼CID** or **▲DIR** to scroll to **Smart call blk**, then press **MENU/SELECT**.
2. Press **▼CID** or **▲DIR** to scroll to **Star name list**, and then press **MENU/SELECT**.
3. Press **▼CID** or **▲DIR** to highlight **Delete all**, then press **MENU/SELECT**. The screen shows **Delete all in star name list?**.
4. Press **MENU/SELECT** again to confirm. The screen displays **Deleted**. There is a confirmation tone.

Screening announcement

If you have set to screen calls without numbers and/or screen uncategorized calls, the callers of one or all of the following incoming call categories will hear a screening announcement.

- ▶ Calls that are “out of area” or with numbers set to “Private”.
- ▶ Calls with numbers that are not in your directory, allow list, or block list, or with absent caller ID number.
- ▶ Calls with caller ID names that are not in your star name list.

The telephone has two screening options, and each option has its default screening announcements.

Screening with caller name - *“Hello. Calls to this number are being screened by Smart call blocker. Please say your name after the tone, then press pound.”*

-OR-

Screening without caller name - *“Hello. Calls to this number are being screened by Smart call blocker. If you’re a family member, friend or invited caller, please press pound to be connected. If you’re a solicitor, please hang up now.”*

You can use these announcements, or record your own name to replace “*this number*” in both announcements.

Call block settings

Play your current announcement of screening with caller name:

Using a cordless handset or the telephone base:

1. Press **CALL BLOCK** when it is not in use.

-OR-

Press **MENU/SELECT** to enter the main menu when the it is not in use. Press **▼CID** or **▲DIR** to scroll to **Smart call blk**, then press **MENU/SELECT**.

2. Press **▼CID** or **▲DIR** to scroll to **Screening annnc**, then press **MENU/SELECT**.

3. Press **▼CID** or **▲DIR** to scroll to **Play annnc**, then press **MENU/SELECT**.

4. Press **MENU/SELECT** again to select **w/ Caller name**.

Play your current announcement of screening without caller name:

Using a cordless handset or the telephone base:

1. Press **CALL BLOCK** when it is not in use.

-OR-

Press **MENU/SELECT** to enter the main menu when it is not in use. Press **▼CID** or **▲DIR** to scroll to **Smart call blk**, then press **MENU/SELECT**.

2. Press **▼CID** or **▲DIR** to scroll to **Screening annnc**, then press **MENU/SELECT**.

3. Press **▼CID** or **▲DIR** to scroll to **Play annnc**, then press **MENU/SELECT**.

4. Press **MENU/SELECT** again to select **w/o Caller name**.

Call block settings

Record your name for all screening announcements:

Using a cordless handset or the telephone base:

1. Press **CALL BLOCK** when it is not in use.
-OR-
Press **MENU/SELECT** to enter the main menu when the handset is not in use. Press **▼CID** or **▲DIR** to scroll to **Smart call blk**, then press **MENU/SELECT**.
2. Press **▼CID** or **▲DIR** to scroll to **Screening annnc**, then press **MENU/SELECT**.
3. Press **MENU/SELECT** to select **Rec your name**. The system announces, *“Record after the tone. Press 5 when you are done.”*
4. Speak towards the handset to record your name. Press 5 to end recording. The announcement with your recorded name plays.

To listen to the announcement with your recorded name again, scroll to **Play annnc** and press **MENU/SELECT**.

Reset all your screening announcements:

Using a cordless handset or the telephone base:

1. Press **CALL BLOCK** when it is not in use.
-OR-
Press **MENU/SELECT** to enter the main menu when it is not in use. Press **▼CID** or **▲DIR** to scroll to **Smart call blk**, then press **MENU/SELECT**.
2. Press **▼CID** or **▲DIR** to scroll to **Screening annnc**, then press **MENU/SELECT**.
3. Press **▼CID** or **▲DIR** to scroll to **Reset annnc**, then press **MENU/SELECT**. The screen shows **Reset to default annnc?**. Press **MENU/SELECT** again to confirm. The screen shows **Annnc. reset to default** before returning to the previous menu.
-OR-
While an announcement is playing, press **MUTE/DELETE**. The screen shows **Annnc. Deleted** before returning to the previous menu.

Your name will be deleted from all the screening announcements, and the telephone will use the default screening announcements described on page 66.

Call block settings

Voice guide to set Smart call blocker

This feature is an easy and alternative way for you to do the basic setup of Smart call blocker. You can follow the voice guide to set your telephone system to allow or to screen all incoming calls, or to screen calls that do not display a phone number.

This feature is only available in the telephone base.

1. Press **CALL BLOCK** on the telephone base when it is not in use.
-OR-
Press **MENU/SELECT** to enter the main menu when it is not in use. Press **▼CID** or **▲DIR** to scroll to **Smart call blk**, then press **MENU/SELECT**.
2. Press **▼CID** or **▲DIR** to scroll to **Voice guide**, then press **MENU/SELECT**.
3. You hear the voice prompt *“Hello! This voice guide will assist you with the basic setup of Smart call blocker...”*
4. Set up your Smart call blocker feature by inputting the designated numbers, as instructed in the voice guide.
 - ▶ Press **1** if you want to screen calls with telephone numbers that are not saved in your directory, allow list or star name list;
 - ▶ Press **2** if you only want to screen calls that do not display a phone number; or
 - ▶ Press **3** if you do not want to screen calls, and want to allow all incoming calls to get through.



Notes:

- ▶ You can press **CANCEL** to quit the voice guide at any time.
- ▶ After a power outage, the system prompts you to set the date and time. After the date and time setting is done or skipped, the system will prompt if you want to set up Smart call blocker via voice guide. Press **MENU/SELECT** to start the setup.

Allowed calls

If Smart call blocker is on, the following types of incoming calls can get through to you and ring on your telephone system:

- Calls with numbers saved in your allow list.
- Calls with numbers saved in your directory, but not in your block list.
- Calls with caller ID names saved in your star name list.



Note: When Smart call blocker is off, or you have set the profile to **Ring all calls** (see page 49), all incoming calls will ring on your telephone system, including calls with numbers saved in the block list.

Allow calls without numbers

If Smart call blocker is on, and you have selected the customized setting to allow calls without numbers, the following type of incoming calls will ring on your telephone system.

- Calls that are “out of area” or with numbers set to “Private”.

Allow uncategorized calls

If Smart call blocker is on, and you have selected the customized setting to allow uncategorized calls, the following type of incoming calls will ring on your telephone system.

- Calls with numbers that are not in your directory, allow list or block list, or with absent caller ID number.
- Calls with caller ID names that are not in your star name list.



Note: If you have set to allow all uncategorized calls, the caller’s number will not be saved to the allow list. If you want to save the caller’s number to your allow list or block list, you can retrieve the number from caller ID log and save it to the allow list or block list. See **Save a caller ID log entry to the block list** on page 55 and **Save a caller ID log entry to the star name list** on page 64.

Blocked calls

If Smart call blocker is on, incoming calls with numbers saved in your block list will not ring. The telephone plays the block announcement *“Calls to this number are being screened by Smart call blocker. The number you are calling is not accepting your call. Please hang up.”* to the caller, and the call will be terminated.



Note: If Smart call blocker is off, or you have set the profile setting to **Ring all calls**, incoming calls with numbers saved in your block list will ring on your telephone system.

Block calls without numbers

If Smart call blocker is on, and you have selected the customized setting to block calls without numbers, the following type of incoming calls will not ring, and the calls will be terminated.

- Calls that are “out of area” or with numbers set to “Private”.

The telephone plays the block announcement *“Calls to this number are being screened by Smart call blocker. The number you are calling is not accepting your call. Please hang up.”* to the caller.



Note: The telephone can respond to remote access code while it is playing the block announcement. This allows you to access your answering system from an unknown number remotely. See **Remote access** on page 95.

Block uncategorized calls

If Smart call blocker is on, and you have selected the customized setting to block uncategorized calls, the following type of incoming calls will not ring, and the calls will be terminated.

- Calls with numbers which are not in your directory, allow list or block list, or with absent caller ID number.
- Calls with caller ID names that are not in your star name list.

The telephone plays the block announcement *“Calls to this number are being screened by Smart call blocker. The number you are calling is not accepting your call. Please hang up.”* to the caller.



Notes:

- If you have set to block all uncategorized calls, the caller’s numbers will not be saved to the block list. If you want to save the caller’s number to your allow list or block list, you can retrieve the number from caller ID log and save it to the allow list or block list. See **Save a caller ID log entry to the block list** on page 55 and **Save a caller ID log entry to the allow list** on page 60. You can also retrieve the name from caller ID log and save it to the star name list. See **Save a caller ID log entry to the star name list** on page 64.
- The telephone can respond to remote access code while it is playing the block announcement. This allows you to access your answering system from an unknown number remotely. See **Remote access** on page 95.

Screen calls without numbers

If Smart call blocker is on, and your telephone is set to screen calls without number, the telephone will not ring when receiving incoming calls that are “out of area” or with numbers set to “Private“. It plays a screening announcement to the caller and asks the caller to respond before putting the call through to you. The telephone has two screening options. You can set your Smart call blocker to screen these calls by asking the callers to record their names and then press the pound key (#). Alternatively, you can screen these calls by only asking the callers to press the pound key (#).

Screen calls without numbers and ask for caller names

When screening a call, the telephone announces to the caller, *“Hello. Calls to this number are being screened by Smart call blocker. Please say your name after the tone, then press pound.”* After the caller completes the request, the telephone announces to the caller *“Please wait a moment while your call is connected.”*. The telephone starts ringing and announces the caller’s name. The telephone screen displays **Screened call** and you can pick up the call. The telephone will then ask whether you want to answer or reject the call, or to forward the call to the answering system.

Screen calls without numbers and do not ask for caller names

When screening a call, the telephone announces to the caller, *“Hello. Calls to this number are being screened by Smart call blocker. If you’re a family member, friend or invited caller, please press pound to be connected. If you’re a solicitor, please hang up now.”* After the caller presses the pound key (#), the telephone announces to the caller *“Please wait a moment while your call is connected.”*. The telephone starts ringing, and you can answer the call. This option is suitable for you to filter calls that uses autodialers to deliver pre-recorded messages, for example, robocalls and telemarketing calls.

Screen calls without numbers



Notes:

- ▶ The telephone announces to the caller with *“Hello. Calls to this number are being screened by Smart call blocker...”* If you have recorded your name in the screening announcements, your recorded name will replace *“this number”* in the announcements. See **Screening announcement** on page 66.
- ▶ If the caller hangs up before the call is screened, or without leaving his/her name while the call is being screened, the call will be logged as missed call in the caller ID log.
- ▶ While a call is being screened, you can press **\ PHONE/FLASH** or **🔊/SPEAKER** to stop screening and answer the call.
- ▶ After the telephone screened a call, and is ringing and announcing the caller’s name, you can press **🔇/OFF/CANCEL** to mute the ringer, or press **CALL BLOCK** to reject the call directly.
- ▶ After you picked up a screened call and the telephone is announcing the screening options, you can press **🔇/OFF/CANCEL** to hang up the call.
- ▶ If you receive a call waiting call without number while on a call, Smart call blocker will not screen the new call. You can press **\ PHONE/FLASH** or **🔊/SPEAKER** to take the new call.
- ▶ Robocalls are unable to respond to the screening announcement, and therefore, will not get through and ring. If you want to allow some robocalls to get through, save their names in the star name list. See page 63.
- ▶ The telephone can respond to remote access code while it is playing the screening announcement. This allows you to access your answering system from an unknown number remotely. See **Remote access** on page 95.

Answer call once

1. When the telephone starts ringing, and the screen displays **Screened call**, press **\ PHONE/FLASH** or **🔊/SPEAKER** to pick up the call. If you have turned on the caller ID announce feature, the telephone announces *“You have a call from...”* and the caller’s name. After you picked up the call, the telephone announces *“To answer the call, press 1. To send this call to the answering system, press 4. To repeat these options, press *”*.
2. Press **1** to answer the call. The telephone number will not be added to your allow list.



Note: To turn on or off caller ID announce, see page 16.

Screen calls without numbers

Send call to answering system

1. When the telephone starts ringing, and the screen displays **Screened call**, press **\ PHONE/FLASH** or **🔊/SPEAKER** to pick up the call. If you have turned on the caller ID announce feature, the telephone announces “*You have a call from...*” and the caller’s name. After you picked up the call, the telephone announces “*To answer the call, press 1. To send this call to the answering system, press 4. To repeat these options, press **”.
2. Press **4** to send the caller to the answering system.



Note: The caller is sent to the answering system and can leave a message even if the answering system is off.

End call

1. When the telephone starts ringing, and the screen displays **Screened call**, press **\ PHONE/FLASH** or **🔊/SPEAKER** to pick up the call. If you have turned on the caller ID feature, the telephone announces “*You have a call from...*” and the caller’s name. After you picked up the call, the telephone announces “*To answer the call, press 1. To send this call to the answering system, press 4. To repeat these options, press **”.
2. If you do not want to take the call, press **🔊 OFF/CANCEL** to end the call.

Screen uncategorized calls

If Smart call blocker is on, and your telephone is set to screen uncategorized calls, the telephone will not ring when receiving the following incoming calls:

- Incoming calls with absent caller ID numbers;
- Incoming calls with numbers that are not in your directory, allow list, nor block list; or
- Incoming calls with names that are not in your star name list.

The telephone plays a screening announcement to the caller and asks the caller to respond before putting the call through to you. There are two screening options. You can set your Smart call blocker to screen these calls by asking the callers to record their names and then press the pound key (#). Alternatively, you can screen these calls by only asking the callers to press the pound key (#).

Screen uncategorized calls and ask for caller names

When screening a call, the telephone announces to the caller, *“Hello. Calls to this number are being screened by Smart call blocker. Please say your name after the tone, then press pound.”* After the caller completes the request, the telephone announces to the caller *“Please wait a moment while your call is connected.”* The telephone starts ringing and announces the caller’s name. The telephone screen displays **Screened call** and you can pick up the call. The telephone will then ask whether you want to answer or reject the call, or to forward the call to the answering system.

Screen uncategorized calls without asking for caller names

When screening a call, the telephone announces to the caller, *“Hello. Calls to this number are being screened by Smart call blocker. If you’re a family member, friend or invited caller, please press pound to be connected. If you’re a solicitor, please hang up now.”* After the caller presses the pound key (#), the telephone announces to the caller *“Please wait a moment while your call is connected.”* The telephone starts ringing, and you can pick up the call. This option is suitable for you to filter calls that uses autodialers to deliver pre-recorded messages, for example, robocalls and telemarketing calls.

Screen uncategorized calls



Notes:

- ▶ You can set Smart call blocker to screen and filter all uncategorized calls from numbers or names that are not saved in your directory, allow list, block list, or star name list. You can easily add incoming phone numbers to your allow list and block list. This allows you to build up your lists of allowed and blocked numbers, and Smart call blocker will know how to deal with these calls when they come in again.
- ▶ The telephone announces to the caller with *“Hello. Calls to this number are being screened by Smart call blocker...”* If you have recorded your name in the screening announcements, your recorded name will replace *“this number”* in the announcements. See **Screening announcement** on page 66
- ▶ If the caller hangs up before the call is screened, or without leaving his/her name while the call is being screened, the call will be logged as missed call in the caller ID log.
- ▶ While a call is being screened, you can press **PHONE/FLASH** or **SPEAKER** to stop screening and answer the call.
- ▶ After the telephone screened a call, and is ringing and announcing the caller’s name, you can press **OFF/CANCEL** to mute the ringer, or press **CALL BLOCK** to reject the call directly. The caller’s number will be added to the block list.
- ▶ After you picked up a screened call and the telephone is announcing the screening options, you can press **OFF/CANCEL** to hang up the call. The caller’s number will not be saved to the block list.
- ▶ If the Smart call blocker feature is on and in screening mode, and you receive a call waiting call:
 - If you have already picked up a screened call, the telephone checks whether the call waiting call’s number can be found in the directory, block list or allow list. It also checks whether the caller name is in the star name list. After that, the telephone displays the caller ID information or **Blocked call** accordingly. You can press **PHONE/FLASH** or **SPEAKER** to take the new call.
 - If the telephone is screening a call, the call waiting call will be ignored and logged as missed call in the caller ID log.
- ▶ Robocalls are unable to respond to the screening announcement, and therefore, will not get through and ring. If you want to allow some robocalls to get through, save their names in the star name list. See page 63.
- ▶ The telephone can respond to remote access code while it is playing the screening announcement. This allows you to access your answering system from an unknown number remotely. See **Remote access** on page 95.

Screen uncategorized calls

Allow call once

1. When the telephone starts ringing, and the screen displays **Screened call**, press **\ PHONE/FLASH** or **🔊/SPEAKER** to pick up the call. If you have turned on the caller ID announce feature, the telephone announces “*You have a call from...*” and the caller’s name. After you picked up the call, the telephone announces “*To answer the call, press 1. To answer and always allow this number, press 2. To block this number, press 3. To send this call to the answering system, press 4. To repeat these options, press **”.
2. Press **1** to answer the call. The telephone number will not be added to your allow list.

Always allow

1. When the telephone starts ringing, and the screen displays **Screened call**, press **\ PHONE/FLASH** or **🔊/SPEAKER** to pick up the call. If you have turned on the caller ID announce feature, the telephone announces “*You have a call from...*” and the caller’s name. After you picked up the call, the telephone announces “*To answer the call, press 1. To answer and always allow this number, press 2. To block this number, press 3. To send this call to the answering system, press 4. To repeat these options, press **”.
2. Press **2** to answer the call. The telephone number will be added to your allow list.

Screen uncategorized calls

Block call

1. When the telephone starts ringing, and the screen displays **Screened call**, press **\ PHONE/FLASH** or **🔊/SPEAKER** to pick up the call. If you have turned on the caller ID announce feature, the telephone announces “*You have a call from...*” and the caller’s name. After you picked up the call, the telephone announces “*To answer the call, press 1. To answer and always allow this number, press 2. To block this number, press 3. To send this call to the answering system, press 4. To repeat these options, press **”.
2. Press **3** or **CALL BLOCK** to block the call. The telephone plays the block announcement “*The number you are calling is not accepting your call. Please hang up.*” to the caller. The telephone number will be added to your block list.

Send call to answering system

1. When the telephone starts ringing, and the screen displays **Screened call**, press **\ PHONE/FLASH** or **🔊/SPEAKER** to pick up the call. If you have turned on the caller ID announce feature, the telephone announces “*You have a call from...*” and the caller’s name. After you picked up the call, the telephone announces “*To answer the call, press 1. To answer and always allow this number, press 2. To block this number, press 3. To send this call to the answering system, press 4. To repeat these options, press **”.
2. Press **4** to forward the call to the answering system.



Note: The call is forwarded to the answering system and the caller can leave a message even if the answering system is off.

Option while on a call

When you are on a call and speaking to the caller, and you do not want to continue the call, you can press the **CALL BLOCK** button on the handset to end the call.

The telephone plays the block announcement “*The number you are calling is not accepting your call. Please hang up.*” to the caller, and the call will be terminated.

The caller’s number will be added to your block list.

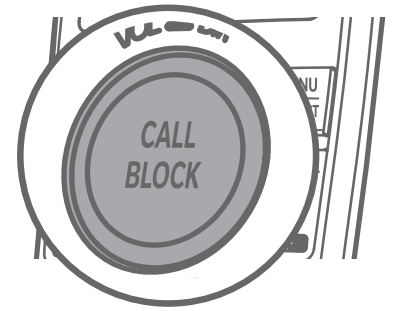

- ▶ Press **CALL BLOCK** on the handset. The screen displays **Block and end?** and the caller’s number, if available. Press **MENU/SELECT** to end the call.



Notes:

- ▶ The caller’s number, if available, will be saved to the block list. The screen displays **Added to block list** after pressing **CALL BLOCK** on the handset. If caller’s number is not available, the screen displays **No number to block.**
- ▶ You can press **CALL BLOCK** on the handset to end the call even if Smart call blocker is turned off.

Answering system settings

Use the answering system menu of a system handset or the telephone base to set up the announcement message, turn on or off the answering system or message alert tone, activate call screening, or change the number of rings, remote access code or message recording time. If you turn off the answering system and you change any setting in the answering system setup menu, the answering machine automatically turns on again.

1. When the device is in idle mode, press **MENU/SELECT** to enter the main menu.
2. Press **▼CID** or **▲DIR** to scroll to **Answering sys**, then press **MENU/SELECT**.

Announcement

Your outgoing announcement plays when calls are answered by the answering system.

The telephone has a default outgoing announcement, *“Hello. Please leave a message after the tone.”* You can use this announcement, or record your own.

You can record an announcement up to 90 seconds. The system does not record any announcement shorter than two seconds.

To play your current outgoing announcement:

Using a cordless handset:

1. When the handset is in idle mode, press **MENU/SELECT** to enter the main menu.
2. Press **▼CID** or **▲DIR** to scroll to **Answering sys**, then press **MENU/SELECT**.
3. Press **MENU/SELECT** again to select **Announcement**.
4. Press **▼CID** or **▲DIR** to scroll to **Play annc**, then press **MENU/SELECT**.

Using the telephone base:

1. When the telephone base is in idle mode, press **MENU/SELECT** to enter the main menu.
2. Press **▼CID** or **▲DIR** to scroll to **Answering sys**, then press **MENU/SELECT**.
3. Press **MENU/SELECT** again to select **Announcement**.
4. Press **▼CID** or **▲DIR** to scroll to **Play annc**, then press **MENU/SELECT**.

Answering system settings

To record a new outgoing announcement:

Using a cordless handset:

1. When the handset is in idle mode, press **MENU/SELECT** to enter the main menu.
2. Press **▼CID** or **▲DIR** to scroll to **Answering sys**, then press **MENU/SELECT**.
3. Press **MENU/SELECT** again to select **Announcement**.
4. Press **MENU/SELECT** to select **Record annc**. The system announces, *“Record after the tone. Press 5 when you are done.”*
5. Speak towards the handset to record your announcement. Press **5** to end recording. Your recorded announcement plays.

To listen to the recorded announcement again, scroll to **Play annc** and press **MENU/SELECT**.

Using the telephone base:

1. When the telephone base is in idle mode, press **MENU/SELECT** to enter the main menu.
2. Press **▼CID** or **▲DIR** to scroll to **Answering sys**, then press **MENU/SELECT**.
3. Press **MENU/SELECT** again to select **Announcement**.
4. Press **MENU/SELECT** again to select **Record annc**. The system announces, *“Record after the tone. Press 5 when you are done.”*
5. Speak towards the telephone base to record your announcement. Press **5** to end recording. Your recorded announcement plays.

To listen to the recorded announcement again, scroll to **Play annc** and press **MENU/SELECT**.

Answering system settings

To delete or reset your outgoing announcement:

Using a cordless handset:

1. When the handset is in idle mode, press **MENU/SELECT**.
2. Press **▼CID** or **▲DIR** to scroll to **Answering sys**, then press **MENU/SELECT**.
3. Press **MENU/SELECT** again to select **Announcement**.
4. Press **▼CID** or **▲DIR** to scroll to **Play annc**, then press **MENU/SELECT**.
5. While the announcement is playing, press **MUTE/DELETE** to delete the announcement. The system announces “*Announcement deleted*” and the screen shows **Annc. Deleted**.

-OR-

1. When the handset is in idle mode, press **MENU/SELECT**.
2. Press **▼CID** or **▲DIR** to scroll to **Answering sys**, then press **MENU/SELECT**.
3. Press **MENU/SELECT** again to select **Announcement**.
4. Press **▼CID** or **▲DIR** to scroll to **Reset annc**, then press **MENU/SELECT**. The screen shows **Reset to default annc?**.
5. Press **MENU/SELECT** again. The screen shows **Annc. reset to default**.

Using the telephone base:

1. When the telephone base is in idle mode, press **MENU/SELECT**.
2. Press **▼CID** or **▲DIR** to scroll to **Answering sys**, then press **MENU/SELECT**.
3. Press **MENU/SELECT** again to select **Announcement**.
4. Press **▼CID** or **▲DIR** to scroll to **Play annc**, then press **MENU/SELECT**.
5. While the announcement is playing, press **MUTE/DELETE** to delete the announcement. The system announces “*Announcement deleted*” and the screen shows **Annc. Deleted**.

When your announcement is deleted, the system answers calls with the default announcement described on page 80. You cannot delete the default announcement.

-OR-

1. When the telephone base is in idle mode, press **MENU/SELECT**.
2. Press **▼CID** or **▲DIR** to scroll to **Answering sys**, then press **MENU/SELECT**.
3. Press **MENU/SELECT** again to select **Announcement**.
4. Press **▼CID** or **▲DIR** to scroll to **Reset annc**, then press **MENU/SELECT**. The screen shows **Reset to default annc?**.
5. Press **MENU/SELECT** again. The screen shows **Annc. reset to default**.

Answering system settings

Answer on/off

Unless you change it, the answering system is on and ready to record messages. You can turn the answering system off, but if you do so, the answering system does not answer calls and record incoming messages.

To turn the answering system on or off:

Using a cordless handset:

1. When the handset is in idle mode, press **MENU/SELECT** to enter the main menu.
2. Press **▼CID** or **▲DIR** to scroll to **Answering sys**, then press **MENU/SELECT**.
3. Press **▼CID** or **▲DIR** to scroll to **Answer ON/OFF**, then press **MENU/SELECT**.
4. Press **▼CID** or **▲DIR** to highlight **On** or **Off**, then press **MENU/SELECT** to save the setting. You hear a confirmation tone.

When the answering system is on, the handset shows **ANS ON**.

Using the telephone base:

- ▶ Press **⓪/ANS ON/OFF** to turn the answering system on or off. If the answering system is turned on, it announces, *“Calls will be answered.”* If the answering system is turned off, it announces, *“Calls will not be answered.”*

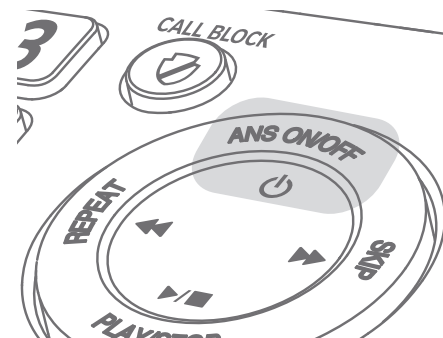

-OR-

1. When the telephone base is in idle mode, press **MENU/SELECT** to enter the main menu.
2. Press **▼CID** or **▲DIR** to scroll to **Answering sys**, then press **MENU/SELECT**.
3. Press **▼CID** or **▲DIR** to scroll to **Answer ON/OFF**, then press **MENU/SELECT**.
4. Press **▼CID** or **▲DIR** to highlight **On** or **Off**, then press **MENU/SELECT** to save the setting. You hear a confirmation tone.



Notes: If the answering system is off and there is an incoming call, the system answers after ten rings and announces, *“Please enter your remote access code.”* For more information about remote access, see page 95.

Answering system settings

Voice guide to set Answering system

This feature is an alternative way for you to do the basic setup of the answering system. You can follow the voice guide to record your own announcement, set the number of rings, and set the message alert tone.

This feature is only available in the telephone base.

1. When the telephone base is in idle mode, press **MENU/SELECT**.
2. Press ▼**CID** or ▲**DIR** to scroll to **Answering sys**, then press **MENU/SELECT**.
3. Press ▼**CID** or ▲**DIR** to scroll to **Voice guide**, then press **MENU/SELECT**.
4. You hear the voice prompt *“This voice guide will assist you with the basic setup of your answering system.”*
5. Set up your answering system by inputting the designated numbers as instructed in the voice guide.



Notes:

- ▶ You can press **CANCEL** to quit the voice guide at any time.
- ▶ After a power outage, the system prompts you to set the date and time, and Smart call blocker. After these settings are done or skipped, the system will prompt if you want to set up the answering system via voice guide. Press **MENU/SELECT** to start the setup.

Answering system settings

Call screening

Use this feature to choose whether incoming messages can be heard over the speaker when they are being recorded. If you turn call screening on, you hear the incoming message.

To change the setting:

Using a cordless handset or the telephone base:

1. When the handset or telephone base is in idle mode, press **MENU/SELECT** to enter the main menu.
2. Press **▼CID** or **▲DIR** to scroll to **Answering sys**, then press **MENU/SELECT**.
3. Press **▼CID** or **▲DIR** to scroll to **Ans sys setup**, then press **MENU/SELECT**.
4. Press **MENU/SELECT** to select **Call screening**.
5. Press **▼CID** or **▲DIR** to choose **On** or **Off**.
6. Press **MENU/SELECT** to save the setting.

Number of rings

You can set the answering system to answer an incoming call after two, three, four, five or six rings. You can also select toll saver. If toll saver is selected, the answering system answers a call after two rings when you have new messages, and after four rings when there are no new messages. This feature allows you to check for new messages and avoid paying long distance charges when calling from out of your local area. By default, the answering system answers an incoming call after four rings.

To set the number of rings:

Using a cordless handset or the telephone base:

1. When the handset or telephone base is in idle mode, press **MENU/SELECT** to enter the main menu.
2. Press **▼CID** or **▲DIR** to scroll to **Answering sys**, then press **MENU/SELECT**.
3. Press **▼CID** or **▲DIR** to scroll to **Ans sys setup**, then press **MENU/SELECT**.
4. Press **▼CID** or **▲DIR** to scroll to **# of rings**, then press **MENU/SELECT**.
5. Press **▼CID** or **▲DIR** to choose among **2, 3, 4, 5, 6** or **Toll saver**.
6. Press **MENU/SELECT** to save the setting.



Note: If Smart call blocker is on, the first ring of all calls will be muted.

Answering system settings

Remote access code

To access your answering system remotely from any touch-tone phone, you need to enter a two-digit number (00-99). By default, the remote access code is **19**.

To change the remote access code:

Using a cordless handset or the telephone base:

1. When the handset or telephone base is in idle mode, press **MENU/SELECT** to enter the main menu.
2. Press **▼CID** or **▲DIR** to scroll to **Answering sys**, then press **MENU/SELECT**.
3. Press **▼CID** or **▲DIR** to scroll to **Ans sys setup**, then press **MENU/SELECT**.
4. Press **▼CID** or **▲DIR** to scroll to **Remote code**, then press **MENU/SELECT**.
5. Use the dialing keys to enter a two-digit number. Press **MUTE/DELETE** on the handset or **MUTE/DELETE** on the telephone base to backspace and delete a digit.
6. Press **MENU/SELECT** to save the setting.

Message alert tone

When the message alert tone is set to **On**, and there is at least one new message, the telephone base beeps every ten seconds. By default, the message alert tone is set to off.

There is no audible alert at the handset.

To change the setting:

Using a cordless handset or the telephone base:

1. When the handset or telephone base is in idle mode, press **MENU/SELECT** to enter the main menu.
2. Press **▼CID** or **▲DIR** to scroll to **Answering sys**, then press **MENU/SELECT**.
3. Press **▼CID** or **▲DIR** to scroll to **Ans sys setup**, then press **MENU/SELECT**.
4. Press **▼CID** or **▲DIR** to scroll to **Msg alert tone**, then press **MENU/SELECT**.
5. Press **▼CID** or **▲DIR** to choose **On** or **Off**.
6. Press **MENU/SELECT** to save the setting.

Answering system settings

Message recording time

You can set the recording time allowed for incoming messages. The message length is three minutes by default.

To change the setting:

Using a cordless handset or the telephone base:

1. When the handset or telephone base is in idle mode, press **MENU/SELECT** to enter the main menu.
2. Press **▼CID** or **▲DIR** to scroll to **Answering sys**, then press **MENU/SELECT**.
3. Press **▼CID** or **▲DIR** to scroll to **Ans sys setup**, then press **MENU/SELECT**.
4. Press **▼CID** or **▲DIR** to scroll to **Recording time**, then press **MENU/SELECT**.
5. Press **▼CID** or **▲DIR** to to choose **3 minutes**, **2 minutes** or **1 minute**, then press **MENU/SELECT** to save the setting.

About the answering system

Answering system and voicemail indicators

Your telephone has separate indicators for two different types of voice messages: those left on its built-in digital answering system and those left at your telephone service provider's voicemail (fees may apply). Your telephone's built-in digital answering system messages and voicemail messages are separate. Each alerts you to new messages differently.

- ▶ If **OO** and **XX New messages** show on the handset and the telephone base, there are new messages in the built-in answering system. To listen to messages recorded on your digital answering system, press **▶/■/PLAY/STOP** on the telephone base (page 91).
- ▶ If **VM** and **New voicemail** display on the handset and the telephone base, your telephone service provider is indicating that it has new voicemail for you. To listen to your voicemail, dial an access number provided by your telephone service provider, followed by a security code or PIN.

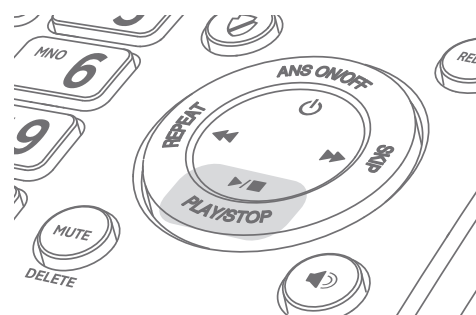

Some telephone service providers bundle or combine multiple services like voicemail and call waiting, so you may not be aware that you have voicemail. To check what services you have and how to access them, contact your telephone service provider.

To use your voicemail service rather than the answering system, turn off the answering system. To use the answering system rather than your voicemail service, contact your telephone service provider to deactivate the voicemail service.



Note: After reviewing all new messages, the number of old messages appears on the message counter.

About the answering system

Using the answering machine and voicemail together

You can also use your telephone answering system and voicemail together by setting your built-in answering system to answer before voicemail answers, as described below. To learn how to program your voicemail settings, contact your telephone service provider. If you are on a call, or the answering system is busy recording a message and you receive another call, the second caller can leave a voicemail message.

Set your answering system to answer calls at least two rings earlier than your voicemail is set to answer. For example, if your voicemail answers after six rings, set your answering system to answer after four rings. Some voicemail providers may program the delay before answering calls in seconds instead of rings. In this case, allow six seconds per ring when determining the appropriate setting.

Message capacity

The answering system can record up to 99 messages, depending on the length of each message. Individual messages can be up to three minutes, and the maximum recording time is approximately 22 minutes. The actual recording time depends on individual message characteristics. Messages remain available for replay until you delete them.

Call screening

To screen a call at the telephone base:

If the answering system and call screening are on, the announcement and the incoming message broadcast at the telephone base when a call is answered by the answering system.

Options while a message is being recorded:

- ▶ Press **▼/VOL/▲** on the telephone base to adjust the call screening volume.
- ▶ Press **▶/■/PLAY/STOP** or **CANCEL** to temporarily silence the call screening.
- ▶ Press **▶/■/PLAY/STOP** to temporarily turn on the call screening if call screening is set to off.
- ▶ Press **🔊/SPEAKER** to answer the call.

To screen a call at the handset:

While a message is being recorded, the handset shows, **To screen call, press [SELECT]**. Press **MENU/SELECT** to screen the call.

About the answering system

Options while a message is being recorded:

- ▶ Press **VOL ▼ CID** or **VOL ▲ DIR** on the handset to adjust the call screening volume.
- ▶ Press **⏸/OFF/CANCEL** to temporarily silence the call screening.
- ▶ Press **MENU/SELECT** to temporarily turn on the call screening if call screening is set to off.
- ▶ Press **🔊/SPEAKER** to broadcast the announcement and the incoming message through the speakerphone. Press again to turn off the speakerphone.

Call intercept

While screening a call, you can stop recording and speak to the caller by pressing **📞/PHONE/FLASH** on the handset or **🔊/SPEAKER** on the telephone base.

Temporarily turning off the message alert tone

If the message alert tone is turned on, the telephone base beeps every ten seconds when there are new messages. Pressing any telephone base key temporarily silences the message alert tone.

If you press **MUTE/DELETE** when in idle mode to temporarily turn off the message alert tone, there is a voice prompt directing you to press **MUTE/DELETE** again to delete all old messages. The message alert tone is temporarily off. Only press **MUTE/DELETE** a second time if you wish to erase all old messages in your answering system.

The message alert tone resumes when you receive another message.

Message playback

To listen to messages at the telephone base:

Press ►/■/PLAY/STOP. Press ►/■/PLAY/STOP again to end the message playback.

- ▶ If there are new and old messages, press ▼CID or ▲DIR to select **Play new msgs** or **Play old msgs**, then press MENU/SELECT or ►/■/PLAY/STOP.
- ▶ If there are only new or only old messages, they will play automatically.

To listen to messages on a cordless handset:

1. When the handset is in idle mode, press MENU/SELECT to enter the main menu.
2. Press MENU/SELECT again to select **Play messages**.
 - ▶ If there are new and old messages, press ▼CID or ▲DIR to select **Play new msgs** or **Play old msgs**, then press MENU/SELECT.
 - ▶ If there are only new or only old messages, they will play automatically.

Options during playback

When messages are playing on the telephone base:

- ▶ Press ▼/VOL/▲ to adjust the message playback volume.
- ▶ Press ►/SKIP to skip to the next message.
- ▶ Press ◀/REPEAT to repeat the message. Press twice to hear the previous message.
- ▶ Press MUTE/DELETE to delete the message.
- ▶ Press ►/■/PLAY/STOP to stop playback.
- ▶ Press ◀/SPEAKER to stop playback. The screen shows **Call back?**, then press MENU/SELECT, or ◀/SPEAKER to call back the caller if the caller's number is available. If the dialing format used is not correct, then use the option, as mentioned below, to choose the correct dialing format before calling back the caller.
- ▶ Press MENU/SELECT to pause playback and show the caller ID information, if available. From here, you can press # (pound key) repeatedly to show the desired dialing option, then press ◀/SPEAKER to call back the caller. You can also press CANCEL to resume playback. If you do not call back within ten seconds, message playback resumes automatically.

Message playback

When messages are playing on the handset:

- ▶ Press **VOL ▼ CID** or **VOL ▲ DIR** to adjust the message playback volume.
- ▶ Press **6** to skip to the next message.
- ▶ Press **4** to repeat the message. Press twice to hear the previous message.
- ▶ Press **MUTE/DELETE** to delete the message.
- ▶ Press **5** or **⏏/OFF/CANCEL** to stop playback.
- ▶ Press **📞/SPEAKER** to switch between speakerphone mode and handset mode.
- ▶ Press **📞/PHONE/FLASH** to stop playback. The screen shows **Call back?**, then press **MENU/SELECT**, **📞/PHONE/FLASH**, or **📞/SPEAKER** to call back the caller if the caller's number is available. If the dialing format used is not correct, then use the option, as mentioned below, to choose the correct dialing format before calling back the caller.
- ▶ Press **MENU/SELECT** to pause playback and show the caller ID information, if available. From here, you can press **#** (pound key) repeatedly to show the desired dialing option, then press **📞/PHONE/FLASH** to call back the caller. You can also press **⏏/OFF/CANCEL** to resume playback. If you do not call back within ten seconds, message playback resumes automatically.

Message playback

Delete all old messages

To delete all old messages on the telephone base:

1. When the telephone is idle, press **MUTE/DELETE**. The system announces, *“To delete all old messages, press DELETE again.”*
2. Press **MUTE/DELETE** again. The system announces, *“All old messages deleted.”*

To delete all old messages on the handset:

1. Press **MENU/SELECT** when in idle mode to enter the main menu.
2. Press **▼CID** or **▲DIR** to scroll to **Answering sys.** Press **MENU/SELECT**.
3. Press **▼CID** or **▲DIR** to scroll to **Delete all old**, then press **MENU/SELECT**. The screen shows **Delete all old messages?**
4. Press **MENU/SELECT** again to confirm.

Recording and playing memos

Memos are your own recorded messages used as reminders for yourself or others using the same answering system. You can record your own memos using a system handset or the telephone base. Play and delete them in the same way as incoming messages.

Record a memo

Using a cordless handset:

1. When the handset is in idle mode, press **MENU/SELECT** to enter the main menu.
2. Press **▼CID** or **▲DIR** to scroll to **Answering sys**. Press **MENU/SELECT**.
3. Press **▼CID** or **▲DIR** to scroll to **Record memo**, then press **MENU/SELECT**. The system announces, *“Record after the tone. Press 5 when you are done.”* You can record a memo for up to four minutes.
4. Speak towards the handset to record a memo.
5. Press **5** to stop recording. The system announces, *“Recorded.”* The system does not save memos shorter than two seconds.

Using the telephone base:

1. When the telephone base is in idle mode, press **MENU/SELECT** to enter the main menu.
2. Press **▼CID** or **▲DIR** to scroll to **Answering sys**. Press **MENU/SELECT**.
3. Press **▼CID** or **▲DIR** to highlight **Record memo**, then press **MENU/SELECT**. The system announces, *“Record after the tone. Press 5 when you are done.”* You can record a memo for up to four minutes.
4. Speak towards the telephone base to record a memo.
5. Press **5** to stop recording. The system announces, *“Recorded.”* The system does not save memos shorter than two seconds.

Play back a memo

Play memos the same way as messages. See **Message playback** on pages 91-93.

Remote access

You can reach your answering system remotely by dialing your home telephone number from any touch-tone telephone.

To remotely reach your answering system:

1. Dial your telephone number from any touch-tone telephone.
2. Once the system answers, enter the two-digit remote access code (**19** is the default code. See page 86 to change it).
 - The system automatically announces the number of new or old messages (if any), and then begins to play them.
3. You can also enter the following remote commands:

Remote commands

1	Press to listen to all messages.
2	Press to listen to new messages only.
3	Press to delete the current message (during playback).
33	Press twice to delete all old messages.
4	Press to repeat the current message (during playback).
5	Press to stop any operation (including recording).
*5	Press to listen to a list of remote commands.
6	Press to skip to the next message (during playback).
*7	Press to record a new announcement.
8	Press to end remote access (the call will be terminated).
0	Press to turn the answering system on or off.

4. Hang up or press **8** to end the calls.

Adding and registering handsets/headsets/speakerphones

Your telephone can support up to 12 DECT 6.0 cordless handsets (AT&T model CL80119, sold separately) or up to 10 cordless handsets and two cordless headsets or speakerphones (sold separately). Visit

www.telephones.att.com/accessories for a list of compatible DECT 6.0 cordless headsets and speakerphones. Each new handset, headset or speakerphone must be registered to the telephone base before use. You must register each handset, headset or speakerphone separately.

To register a cordless headset or speakerphone to this telephone system, please refer to the corresponding user's manual for details. To register a cordless handset, see below.

The handsets provided within your product box are already registered as **HANDSET 1**, and so forth. Additional handsets are assigned numbers in the sequential order they are registered (up to **HANDSET 12**).

Register a handset to the telephone base

1. Before you begin registration, make sure the handset is out of the telephone base or charger and shows **To register HS, see manual**.
2. Put the handset you wish to register on the telephone base cradle.
3. Both the handset and the telephone base show **Registering... Please wait** and the **IN USE** light on the telephone base turns on. **HANDSET X Registered** appears on the handset screen (**HANDSET** represents the handset name, **X** represents the handset number). Both the handset and the telephone base beep and the **IN USE** light turns off. The handset is now registered with the telephone base.

If registration fails, the system will automatically try to register again. If registration fails after the third try, **Registration Failed** appears on both screens. The handset shows **To register HS, see manual** and the telephone base returns to idle mode. This may take up to five minutes to occur. Please start again from Step 1.



Notes:

- ▶ You cannot register a handset if any other system handset is in use.
- ▶ If you try to register more than 12 handsets to the telephone base, the telephone base shows **Registration slots are full** and sounds two beeps.

Deregistering handsets

You may need to deregister your handsets if:

- ▶ You have 12 registered handsets and need to replace a handset.

-OR-

- ▶ You wish to change the designated handset number of your registered handsets.



You must first deregister ALL handsets, and then register each handset you wish to use again, one at a time.

Please read carefully through all the instructions on this page before beginning the deregistration process.

Deregister all handsets from the telephone base

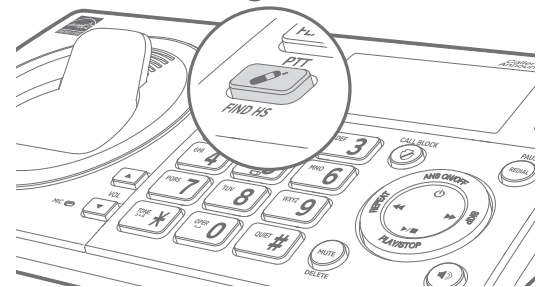
In addition to the cordless handsets, this operation will also deregister all cordless headsets and speakerphones registered to your telephone base.



1. Make sure that all handsets are out of the telephone base and chargers before you begin deregistration.
2. Press and hold /**FIND HS** on the telephone base for about ten seconds (until the **IN USE** light starts to flash). The telephone base screen shows **Registering... Please wait** for five seconds, then it shows **Deregister all devices?**. Release /**FIND HS**.
3. Immediately press /**FIND HS** again while the **IN USE** light is still flashing. (If the light stops flashing, start again with Step 1.)
4. It takes up to ten seconds to complete the deregistration process. Before registering the handset again, wait for the cordless handset screen to display **To register HS, see manual**.
5. To register the handset(s) to the telephone base again, follow the registration instructions on the previous page.



Notes:

- ▶ If the deregistration process fails, you may need to reset the system and try again. To reset, unplug the power from the telephone base and plug it back in.
- ▶ You cannot deregister the handsets if any other system handset is in use.
- ▶ Even if the battery is depleted, you can still deregister the handsets by following the steps mentioned above. After the handset is charged for at least ten minutes, the screen shows **To register HS, see manual**.

Troubleshooting

If you have difficulty with your phone please try the following suggestions. For Customer Service, visit our website at **www.telephones.att.com** or call **1 (800) 222-3111**. In Canada, dial **1 (866) 288-4268**.

For more detailed instructions, refer to the online Complete user's manual at **www.telephones.att.com/manuals**.

My telephone doesn't work at all.

- ▶ Make sure the power cord is securely plugged in.
- ▶ Make sure you plug the battery connector securely into the cordless handset.
- ▶ Make sure you plug the telephone line cord securely and firmly into the telephone base and the telephone wall jack.
- ▶ Charge the battery in the cordless handset for at least ten hours. For optimum daily performance, return the cordless handset to the telephone base or charger when not in use.
- ▶ If the battery is depleted, it may take approximately 30 minutes to charge the handset before it shows **Low battery**. See page 9 for details.
- ▶ Reset the telephone base. Unplug the electrical power. Wait for approximately 15 seconds, then plug it back in. Allow up to one minute for the cordless handset and telephone base to reset.
- ▶ You may need to purchase a new battery. Please refer to **Battery installation and charging** in this user's manual on pages 9-10.

The display shows No line. I cannot get a dial tone.

- ▶ Try all the suggestions mentioned above.
- ▶ If the previous suggestions do not work, disconnect the telephone line cord from your telephone and connect the telephone line cord to another telephone.
 - ▶ If there is no dial tone on that other telephone either, your telephone line cord may be defective. Install a new telephone line cord.
 - ▶ If changing the telephone line cord does not help, the wall jack (or the wiring to this wall jack) may be defective. Try using a different wall jack in your home to connect your CL83519 telephone, or contact your telephone service provider (charges may apply).

Troubleshooting

I cannot dial out.

- ▶ Try all the suggestions mentioned above.
- ▶ Make sure you have a dial tone before dialing. The cordless handset may take a second or two to find the telephone base and produce a dial tone. This is normal. Wait an extra second before dialing.
- ▶ Eliminate any background noise. Noise from a television, radio or other appliances may cause the phone to not dial out properly. If you cannot eliminate the background noise, first try muting the cordless handset before dialing, or dialing from another room with less background noise.
- ▶ If other phones in your home are having the same problem, contact your telephone service provider (charges may apply).

My cordless handset isn't performing normally.

- ▶ Make sure you plug the power cord securely into the telephone base. Plug the power adapter into a different working electrical outlet without a wall switch.
- ▶ Move the cordless handset closer to the telephone base. You may have moved out of range.
- ▶ Reset the telephone base. Unplug the electrical power. Wait for 15 seconds, then plug it back in. Allow up to one minute for the cordless handset and telephone base to reset.
- ▶ Other electronic products such as HAM radios and other DECT phones, can cause interference with your cordless phone. Try installing your phone as far away as possible from these types of electronic devices.

The batteries do not hold a charge.

- ▶ Charge the battery in the cordless handset for at least ten hours. For optimum daily performance, return the cordless handset to the telephone base or charger when not in use.
- ▶ If the battery is depleted, it may take approximately 30 minutes to charge the handset before it shows **Low battery**. Refer to the table on page 9 for details.
- ▶ You may need to purchase a new battery. Please refer to **Battery installation and charging** in this user's manual on pages 9-10.

Troubleshooting

I experience poor sound quality when using the handset speakerphone.

- ▶ For increased sound quality while using the handset speakerphone, place the handset on a flat surface with the dial pad facing up.

My caller ID isn't working.

- ▶ Caller ID is a subscription service. You must subscribe to this service from your telephone service provider for this feature to work on your phone.
- ▶ The caller may not be calling from an area that supports caller ID.
- ▶ Both your and the caller's telephone service providers must use caller ID compatible equipment.
- ▶ If you subscribe to high-speed Internet service (DSL - digital subscriber line) through your telephone line, you must install a DSL filter between the telephone line cord and the telephone wall jack (page 7). The filter prevents noise and caller ID problems resulting from DSL interference. Please contact your DSL service provider for more information about DSL filters.

System does not receive caller ID when on a call.

- ▶ Make sure you subscribe to caller ID with call waiting features from your telephone service provider. Caller ID features works only if both you and the caller are in areas offering caller ID service, and if both telephone service providers use compatible equipment.

System screens all my incoming calls.

- ▶ You may have set Smart call blocker to screen calls without numbers and uncategorized calls. The telephone asks callers to announce their names or press the pound key (#). We recommend that you add the phone numbers of your family members and friends, and desired businesses to your **Directory** (see page 39) or **Allow list** (see page 58), or add their names to the **Star name list** (see page 63). This will avoid Smart call blocker to screen their calls.
- ▶ To turn Smart call blocker off, see **Set Smart call blocker on/off** on page 49.

Troubleshooting

While screening a call, the telephone suddenly stops screening and connects to the call.

- ▶ Another handset may have picked up the screening call.
- ▶ If you have other telephone system sharing the same telephone line, and someone picks up the call on the other telephone system while the screening is in progress, the screening process will be terminated and connect you to the caller.

My telephone block calls from someone I know.

- ▶ You may have saved the caller's number to your block list. To remove the number from the block list. See **Delete a block entry** on page 57.

Blocking calls with numbers saved in my block list only.

- ▶ If you want to block calls with numbers saved in your block list only, and allow all other calls to get through to you, change the settings to accept calls without numbers and uncategorized calls. See **Control calls without numbers** on page 50 and **Control uncategorized calls** on page 51.

Blocking all unknown calls.

- ▶ If you want to block all unknown calls with numbers or names that are not in your directory, allow list or star name list, change the settings to block calls without numbers and uncategorized calls. See **Control calls without numbers** on page 50 and **Control uncategorized calls** on page 51.

Forwarding all unknown calls to the answering system.

- ▶ If you want to forward all unknown calls with numbers or names that are not in your directory, allow list or star name list to the answering system, see **Control calls without numbers** on page 50 and **Control uncategorized calls** on page 51 to change the settings.

I've set my LCD language to Spanish or French and I don't know how to change it back to English.

- ▶ Press **MENU/SELECT** on your handset or base in idle mode, then enter **364#** on the handset or base. You hear a confirmation tone.

Troubleshooting

I cannot retrieve voicemail messages.

Your telephone has both a built-in answering system and voicemail indication. They are independent features and each alerts you to new messages differently. If you subscribe to voicemail service from your telephone service provider, contact your telephone service provider for more information on how to access your voicemail.

I get noise, static, or weak signals even when I'm near the telephone base.

- ▶ If you subscribe to high-speed Internet service (DSL - digital subscriber line) through your telephone line, you must install a DSL filter between the telephone line cord and the telephone wall jack (page 7). The filter prevents noise and caller ID problems as a result of DSL interference. Please contact your DSL service provider for more information about DSL filters.
- ▶ You may be able to improve the performance of your cordless phone by installing your new telephone base as far as possible from any other existing cordless telephone system that may already be installed.
- ▶ Other electronic products such as HAM radios and other DECT phones, can cause interference with your cordless phone. Try installing your phone as far away as possible from these types of electronic devices.
- ▶ Do not install this phone near a microwave oven or on the same electrical outlet. You may experience decreased performance while the microwave oven is operating.
- ▶ If you plug your phone in with a modem or a surge protector, plug the phone (or modem/surge protector) into a different location. If this does not solve the problem, relocate your phone or modem farther apart from one another, or use a different surge protector.
- ▶ Move your phone to a higher location. The phone may have better reception in a high area.
- ▶ If other phones in your home are having the same problem, contact your telephone service provider (charges may apply).

Troubleshooting

System does not answer after the correct number of rings.

- ▶ Make sure that the answering system is on. **ANS ON** should show on the handset and the **📞/ANS ON/OFF** light on the telephone base should be on.
- ▶ If toll saver is activated, the number of rings changes to two when you have new messages stored.
- ▶ If the memory is full or the system is off, the system will answer after 10 rings.
- ▶ In some cases, the answering system is affected by the ringing system used by your telephone service provider.
- ▶ If you subscribe to voicemail service, change the number of rings so that your answering system answers before your voicemail. To determine how many rings activate your voicemail, contact your telephone service provider.
- ▶ If there is a fax machine connected to the same telephone line, try disconnecting the fax machine. If that solves the problem, consult your fax machine documentation for information on compatibility with answering systems.

Maintenance

Taking care of your telephone

- ▶ Your cordless telephone contains sophisticated electronic parts, so you must treat it with care.
- ▶ Avoid rough treatment.
- ▶ Place the handset down gently.
- ▶ Save the original packing materials to protect your telephone if you ever need to ship it.

Avoid water

- ▶ You can damage your telephone if it gets wet. Do not use the handset in the rain, or handle it with wet hands. Do not install the telephone base near a sink, bathtub or shower.

Electrical storms

- ▶ Electrical storms can sometimes cause power surges harmful to electronic equipment. For your own safety, take caution when using electric appliances during storms.

Cleaning your telephone

- ▶ Your telephone has a durable plastic casing that should retain its luster for many years. Clean it only with a soft cloth slightly dampened with water or mild soap.
- ▶ Do not use excess water or cleaning solvents of any kind.

Remember that electrical appliances can cause serious injury if used when you are wet or standing in water. If the telephone base should fall into water, DO NOT RETRIEVE IT UNTIL YOU UNPLUG THE POWER CORD AND TELEPHONE LINE CORDS FROM THE WALL. Pull the unit out by the unplugged cords.

Important safety information



This symbol is to alert you to important operating or servicing instructions that may appear in this user's manual. Always follow basic safety precautions when using this product to reduce the risk of injury, fire, or electric shock.

Safety information

- ▶ Read and understand all instructions in the user's manual. Observe all markings on the product.
- ▶ Avoid using a telephone during a thunderstorm. There may be a slight chance of electric shock from lightning.
- ▶ Do not use a telephone in the vicinity of a gas leak. Under certain circumstances, a spark may be created when the adapter is plugged into the power outlet, or when the handset is replaced in its cradle. This is a common event associated with the closing of any electrical circuit. In an inadequately ventilated environment, the user should not plug the phone into a power outlet, nor put a charged handset into the cradle where there are concentrations of flammable or flame-supporting gases. A spark in such an environment could create a fire or explosion. Such environments may include: medical use of oxygen without adequate ventilation; industrial gases (cleaning solvents; gasoline vapors; etc.); a leak of natural gas; etc.
- ▶ Do not use this product near water or when you are wet. For example, do not use it in a wet basement or shower, nor next to a swimming pool, bathtub, kitchen sink, and laundry tub. Do not use liquids or aerosol sprays for cleaning. If the product comes in contact with any liquid, unplug any line or power cord immediately. Do not plug the product back in until it has dried thoroughly.
- ▶ Install this product in a protected location where no one can trip over any line or power cords. Protect cords from damage or abrasion.
- ▶ If this product does not operate normally, see the **Troubleshooting** section on pages 98-103 of this user's manual. If you cannot solve the problem, or if the product is damaged, refer to the **Limited warranty** section on pages 113-115. Do not open this product except as directed in your user's manual. Opening the product or reassembling it incorrectly may expose you to hazardous voltages or other risks.
- ▶ Replace batteries only, as described in your user's manual (pages 9-10). Do not burn or puncture batteries — they contain caustic chemicals.
- ▶ The power adapters are intended to be correctly oriented in a vertical or floor mount position. The prongs are not designed to hold the plug in place if it is plugged into a ceiling, under-the-table or cabinet outlet.

Important safety information



CAUTIONS:

- ▶ Use only the power adapters provided with this product. To obtain a replacement, visit our website at **www.telephones.att.com** or call **1 (800) 222-3111**. In Canada, dial **1 (866) 288-4268**. For more detailed instructions, refer to the online Complete user's manual at **www.telephones.att.com/manuals**.
- ▶ Use only the supplied rechargeable battery or replacement battery (model BT183342/BT283342). To order, visit our website at **www.telephones.att.com** or call **1 (800) 222-3111**. In Canada, dial **1 (866) 288-4268**.
- ▶ To prevent risk of fire or battery explosion, replace with the correct battery type. Dispose of used batteries according to the instructions.

Especially about cordless telephones

- ▶ Privacy: The same features that make a cordless telephone convenient create some limitations. Telephone calls are transmitted between the telephone base and the handset by radio waves, so there is a possibility that your cordless telephone conversations could be intercepted by radio receiving equipment within range of the cordless handset. For this reason, you should not think of cordless telephone conversations as being as private as those on corded telephones.
- ▶ Electrical power: The telephone base of this cordless telephone must be connected to a working electrical outlet which is not controlled by a wall switch. Calls cannot be made from the handset if the telephone base is unplugged, switched off or if the electrical power is interrupted.
- ▶ Potential TV interference: Some cordless telephones operate at frequencies that may cause interference to TVs and VCRs. To minimize or prevent such interference, do not place the telephone base of the cordless telephone near or on top of a TV or VCR. If interference is experienced, moving the cordless telephone farther away from the TV or VCR will often reduce or eliminate the interference.
- ▶ Rechargeable batteries: This product contains nickel-metal hydride rechargeable batteries. Exercise care in handling batteries in order not to create a short circuit with conductive material such as rings, bracelets and keys. The battery or conductor may overheat and cause harm. Observe proper polarity between the battery and the battery charger.
- ▶ Nickel-metal hydride rechargeable batteries: Dispose of these batteries in a safe manner. Do not burn or puncture. Like other batteries of this type, if burned or punctured, they could release caustic material which could cause injury.



The RBRC® Seal means that the manufacturer is voluntarily participating in an industry program to collect and recycle nickel-metal hydride rechargeable batteries when taken out of service within the United States. These batteries may be taken to a participating local retailer of replacement batteries or recycling center. Or you may call 1-800-8-BATTERY® for locations accepting spent Ni-MH batteries.

RBRC® and 1-800-8-BATTERY® are registered trademarks of the Rechargeable Battery Recycling Corporation.

Important safety information

Precautions for users of implanted cardiac pacemakers

Cardiac pacemakers (applies only to digital cordless telephones):

Wireless Technology Research, LLC (WTR), an independent research entity, led a multidisciplinary evaluation of the interference between portable wireless telephones and implanted cardiac pacemakers. Supported by the U.S. Food and Drug Administration, WTR recommends to physicians that:

Pacemaker patients

Should keep wireless telephones at least six inches from the pacemaker.

Should NOT place wireless telephones directly over the pacemaker, such as in a breast pocket, when it is turned ON.

Should use the wireless telephone at the ear opposite the pacemaker.

WTR's evaluation did not identify any risk to bystanders with pacemakers from other persons using wireless telephones.

ECO mode

This power conserving technology reduces power consumption for optimal battery performance. The ECO mode activates automatically whenever the handset is synchronized with the telephone base.

Especially about telephone answering systems

Two-way recording: This unit does not sound warning beeps to inform the other party that the call is being recorded. To ensure that you are in compliance with any federal or state regulations regarding recording a telephone call, you should start the recording process and then inform the other party that you are recording the conversation.

SAVE THESE INSTRUCTIONS

For C-UL compliance

In compliance with the bilingual requirements for safety, caution, and warning markings of Canadian Federal and Provincial/Territorial statutes and regulations, the French version of Important safety information is included.

Mesures de sécurité importantes



Ce symbole vous alertera d'informations importantes ou d'instructions d'entretien pouvant apparaître dans ce guide d'utilisation. Respectez toujours les mesures de sécurité et de sécurité de base lorsque vous utilisez ce produit, afin de réduire les risques de blessures, d'incendie, ou d'électrocution.

Information relative à la sécurité

- ▶ Veuillez lire et comprendre toutes les instructions de ce guide d'utilisation. Relectez toutes les inscriptions apparaissant sur le produit.
- ▶ Évitez d'utiliser le téléphone pendant un orage. Il pourrait y avoir un faible risque d'électrocution.
- ▶ N'utilisez pas un téléphone près d'une fuite de gaz. Dans certaines circonstances, une flammèche pourrait se produire lorsque l'adaptateur est branché à une prise de courant, ou lorsque le combiné est déposé sur son chargeur. Ceci est un événement fréquent associé avec la fermeture d'un circuit électrique. L'utilisateur ne devrait pas brancher un téléphone dans une prise de courant, et ne devrait pas déposer un combiné chargé dans le chargeur, si le téléphone se trouve dans un environnement comportant une concentration de gaz inflammables ou ignifuges, à moins de se trouver dans un endroit où la ventilation est adéquate. Une flammèche dans de tels environnements pourrait provoquer une explosion. De tels environnements peuvent comprendre : les endroits où de l'oxygène à des fins médicales est utilisé sans ventilation adéquate; des endroits où se trouvent des gaz industriels (dissolvants de nettoyage, des vapeurs de gazoline, etc.), une fuite de gaz naturel, etc.
- ▶ N'utilisez pas ce produit près de l'eau ou lorsque vous êtes mouillés. Par exemple, ne l'utilisez pas dans des sous-sols humides ou sous la douche, ou près d'une piscine, d'un bain, d'un évier de cuisine, ou d'une cuve de lavage. N'utilisez pas de liquides, ou de vaporisateurs aérosol de nettoyage. Si le produit entre en contact avec du liquide, débranchez immédiatement le fil téléphonique ou le cordon d'alimentation. Ne rebranchez pas le produit avant qu'il soit complètement sec.
- ▶ Installez cet appareil dans un endroit protégé où personne ne peut trébucher sur les cordons d'alimentation ou la ligne téléphonique. Protégez les câbles contre les dommages ou l'abrasion.
- ▶ Si le produit ne fonctionne pas correctement, consultez la section **Dépannage (Troubleshooting)** des pages 98-103 de ce guide d'utilisation. Si vous ne pouvez pas régler le problème, ou si le produit est endommagé, consultez la section **Garantie limitée (Limited warranty)** des pages 113-115. N'ouvrez pas ce produit, sauf tel qu'indiqué dans le guide d'utilisation. L'ouverture du produit ou le remontage inadéquat pourrait vous exposer à des tensions dangereuses ou autres dangers.
- ▶ Remplacez les piles uniquement tel que décrit dans votre guide d'utilisation (pages 9-10). N'incinerez pas et ne percez pas les piles — elles contiennent des produits chimiques caustiques.
- ▶ Les adaptateurs secteurs sont conçus pour être orientés verticalement ou installés sur le plancher. Les broches ne sont pas conçues pour se maintenir en place si la fiche est branchée dans une prise de courant au plafond, sous la table ou sous une armoire.

Appendix For C-UL compliance



MISES EN GARDE:

- ▶ N'utilisez que les adaptateurs inclus avec ce produit. Pour obtenir une pièce de rechange, visitez notre site Web au **www.telephones.att.com** ou composez le **1-800-222-3111**. Au Canada, composez le **1-866-288-4268**.
- ▶ N'utilisez que la pile de rechargeable incluse ou une pile de rechange (modèle BT183342/ BT283342). Pour commander, visitez notre site Web **www.telephones.att.com** ou composez le **1-800-222-3111**. Au Canada, composez le **1-866-288-4268**.
- ▶ Afin de prévenir les risques d'incendie ou d'explosion de la pile, remplacez la pile avec une pile du même type. Jetez les piles épuisées en respectant les instructions.

Spécifiquement en rapport avec les téléphones sans fil

- ▶ Confidentialité : Les mêmes caractéristiques qui rendent les téléphones sans fil si pratiques créent également des restrictions. Les appels téléphoniques sont transmis entre le socle du téléphone et le combiné par le biais d'ondes radio, et il se peut que vos conversations téléphoniques soient interceptées par d'autres équipements de réception d'ondes radio au sein de la portée du téléphone sans fil. Pour cette raison, vous ne devez pas considérer les conversations sur un téléphone sans fil comme étant aussi confidentielles que celles d'un téléphone à cordon.
- ▶ Alimentation électrique : La base de ce téléphone sans fil doit être branchée à une prise de courant électrique fonctionnelle. La prise électrique ne doit pas être contrôlée par un interrupteur mural. Les appels ne peuvent pas être effectués à partir du combiné si la base n'est pas branchée, si elle est hors fonction ou si le courant électrique est coupé.
- ▶ Interférences potentielles aux téléviseurs : Certains téléphones sans fil fonctionnent sur des fréquences pouvant causer des interférences aux téléviseurs et magnétoscopes. Pour réduire ou prévenir de tels parasites, ne pas déposer la base du téléphone sans fil à proximité d'un téléviseur ou magnétoscope, ni directement sur celui-ci. Si votre téléviseur affiche des interférences, éloignez le téléphone sans fil de celui-ci afin de réduire les parasites.
- ▶ Piles rechargeables : Vous devez recycler ou jeter les piles de manière écologique. Ne pas jeter dans les rejets domestiques. Ne pas brûler ni percer les piles. Comme pour les autres piles du même type, si elles sont brûlées ou percées, des matières corrosives peuvent s'en échapper, ce qui risque de causer des brûlures ou autres blessures corporelles.
- ▶ Piles rechargeables à l'hydrure métallique de nickel : Jetez ces piles de manière sécuritaire. N'incinerez pas et ne percez pas les piles. Comme pour les autres piles du même type, si elles sont brûlées ou percées, des matières corrosives peuvent s'en échapper, ce qui risque de causer des brûlures ou autres blessures corporelles.



Le sceau de l'organisme de recyclage RBRC^{MD} sur les piles à l'hydrure métallique de nickel signifie que le fabricant de cet appareil participe volontairement au programme industriel visant à reprendre et recycler ce type de piles lorsqu'elles ne servent plus, au sein du territoire des États-Unis et du Canada. Vous devez apporter ces piles chez un détaillant participant ou le centre de recyclage le plus près de chez vous. Ou vous pouvez composer le 1-800-8-BATTERY^{MD} afin de connaître les endroits qui acceptent les piles à l'hydrure métallique de nickel mortes.

RBRC^{MD} et 1-800-8-BATTERY^{MD} sont des marques déposées de Rechargeable Battery Recycling Corporation.

For C-UL compliance

Mesures préventives pour les utilisateurs de stimulateurs cardiaques implantés dans l'organisme

Stimulateurs cardiaques (ne s'applique qu'aux téléphones sans fil numériques) :

L'organisme 'Wireless Technology Research, LLC (WTR)', une firme de recherche indépendante, a mené une évaluation pluridisciplinaire des interférences entre les téléphones sans fil portatifs et les stimulateurs cardiaques implantés dans l'organisme. Appuyée par l'Administration des aliments et drogues (FDA) des États-unis, la firme WTR recommande aux médecins :

Avis aux détenteurs de stimulateurs cardiaques

Ils doivent tenir le téléphone sans fil à une distance d'au moins six pouces du stimulateur cardiaque.

Ils ne doivent PAS placer le téléphone sans fil directement sur le stimulateur cardiaque, tel que dans une poche de chemise, lorsque celui-ci est en fonction.

Ils doivent utiliser le téléphone sans fil en l'appuyant sur l'oreille qui se trouve dans la direction opposée au stimulateur cardiaque.

L'étude effectuée par l'organisme WRS n'a pas identifié de risque pour les détenteurs de simulateurs cardiaques causé par les gens qui utilisent un téléphone sans fil à proximité de ceux-ci.

Mode ECO

Lorsque le socle communique avec le combiné, le mode ECO sera activé automatiquement. Ceci réduit la consommation d'énergie selon la distance entre le socle du téléphone et le combiné.

Spécifiquement en rapport avec les répondeurs téléphoniques

Enregistrement deux voies : Cet appareil n'émet pas de bips d'avertissement qui permettent de prévenir l'autre partie que vous enregistrez la conversation. Pour assurer votre conformité aux règlements fédéraux ou provinciaux en rapport avec les enregistrements des conversations téléphoniques, vous devriez informer l'autre partie lorsque vous activez l'enregistrement.

CONSERVEZ CES INSTRUCTIONS

FCC Part 68 and ACTA

This equipment complies with Part 68 of the FCC rules and with technical requirements adopted by the Administrative Council for Terminal Attachments (ACTA). The label on the back or bottom of this equipment contains, among other things, a product identifier in the format US:AAAEQ##TXXXX. This identifier must be provided to your telephone service provider upon request.

The plug and jack used to connect this equipment to premises wiring and the telephone network must comply with the applicable Part 68 rules and technical requirements adopted by ACTA. A compliant telephone cord and modular plug is provided with this product. It is designed to be connected to a compatible modular jack that is also compliant. An RJ11 jack should normally be used for connecting to a single line and an RJ14 jack for two lines. See the installation instructions in the user's manual.

The Ringer Equivalence Number (REN) is used to determine how many devices you may connect to your telephone line and still have them ring when you are called. The REN for this product is encoded as the 6th and 7th characters following the US: in the product identifier (e.g., if ## is 03, the REN is 0.3). In most, but not all areas, the sum of all RENs should be five (5.0) or less. For more information, please contact your telephone service provider.

This equipment must not be used with Party Lines. If you have specially wired alarm dialing equipment connected to your telephone line, ensure the connection of this equipment does not disable your alarm equipment. If you have questions about what will disable the alarm equipment, consult your telephone service provider or a qualified installer.

If this equipment is malfunctioning, it must be unplugged from the modular jack until the problem has been corrected. Repairs to this telephone equipment can only be made by the manufacturer or its authorized agents. For repair procedures, follow the instructions outlined under the Limited warranty.

If this equipment is causing harm to the telephone network, the telephone service provider may temporarily discontinue your telephone service. The telephone service provider is required to notify you before interrupting service. If advance notice is not practical, you will be notified as soon as possible. You will be given the opportunity to correct the problem and the telephone service provider is required to inform you of your right to file a complaint with the FCC. Your telephone service provider may make changes in its facilities, equipment, operation, or procedures that could affect the proper functioning of this product. The telephone service provider is required to notify you if such changes are planned.

If this product is equipped with a corded or cordless handset, it is hearing aid compatible.

If this product has memory dialing locations, you may choose to store emergency telephone numbers (e.g., police, fire, medical) in these locations. If you do store or test emergency numbers, please:

- ▶ Remain on the line and briefly explain the reason for the call before hanging up.
- ▶ Perform such activities in off-peak hours, such as early morning or late evening.

FCC Part 68 and ACTA

Industry Canada

This device contains licence-exempt transmitter(s)/receiver(s) that comply with Innovation, Science and Economic Development Canada's licence-exempt RSS(s). Operation is subject to the following two conditions:

- (1) This device may not cause interference.
- (2) This device must accept any interference, including interference that may cause undesired operation of the device.

Privacy of communications may not be ensured when using this telephone.

The term "IC:" before the certification/registration number only signifies that the Industry Canada technical specifications were met.

The Ringer Equivalence Number (REN) for this terminal equipment is 1.0. The REN indicates the maximum number of devices allowed to be connected to a telephone interface. The termination of an interface may consist of any combination of devices subject only to the requirement that the sum of the RENs of all the devices not exceed five.

This product meets the applicable Innovation, Science and Economic Development Canada technical specifications.

FCC Part 15

NOTE: This equipment has been tested and found to comply with the requirements for a Class B digital device under Part 15 of the Federal Communications Commission (FCC) rules. These requirements are intended to provide reasonable protection against harmful interference in a residential installation. This equipment generates, uses and can radiate radio frequency energy and, if not installed and used in accordance with the instructions, may cause harmful interference to radio communications. However, there is no guarantee that interference will not occur in a particular installation. If this equipment does cause harmful interference to radio or television reception, which can be determined by turning the equipment off and on, the user is encouraged to try to correct the interference by one or more of the following measures:

- ▶ Reorient or relocate the receiving antenna.
- ▶ Increase the separation between the equipment and receiver.
- ▶ Connect the equipment into an outlet on a circuit different from that to which the receiver is connected.
- ▶ Consult the dealer or an experienced radio/TV technician for help.

WARNING: Changes or modifications to this equipment not expressly approved by the party responsible for compliance could void the user's authority to operate the equipment.

This device complies with Part 15 of the FCC Rules. Operation is subject to the following two conditions: (1) this device may not cause harmful interference, and (2) this device must accept any interference received, including interference that may cause undesired operation. Privacy of communications may not be ensured when using this telephone.

To ensure safety of users, the FCC has established criteria for the amount of radio frequency energy that can be safely absorbed by a user or bystander according to the intended usage of the product. This product has been tested and found to comply with the FCC criteria. The handset may be safely held against the ear of the user. The telephone base shall be installed and used such that parts of the user's body other than the hands are maintained at a distance of approximately 20 cm (8 inches) or more.

This Class B digital apparatus complies with Canadian requirement:

CAN ICES-3 (B)/NMB-3(B)

Limited warranty

The AT&T brand is used under license - any repair, replacement or warranty service, and all questions about this product should be directed to our website at **www.telephones.att.com** or call **1 (800) 222-3111**. In Canada, dial **1 (866) 288-4268**.

For more detailed instructions, refer to the online Complete user's manual at **www.telephones.att.com/manuals**.

1. What does this limited warranty cover?

The manufacturer of this AT&T branded product warrants to the holder of a valid proof of purchase ("CONSUMER" or "you") that the product and all accessories provided in the sales package ("PRODUCT") are free from defects in material and workmanship, pursuant to the following terms and conditions, when installed and used normally and in accordance with the PRODUCT operating instructions. This limited warranty extends only to the CONSUMER for products purchased and used in the United States of America and Canada.

2. What will be done if the PRODUCT is not free from defects in materials and workmanship during the limited warranty period ("materially defective PRODUCT")?

During the limited warranty period, the manufacturer's authorized service representative will repair or replace at the manufacturer's option, without charge, a materially defective PRODUCT. If the manufacturer repairs the PRODUCT, they may use new or refurbished replacement parts. If the manufacturer chooses to replace the PRODUCT, they may replace it with a new or refurbished PRODUCT of the same or similar design. The manufacturer will retain defective parts, modules, or equipment. Repair or replacement of the PRODUCT, at the manufacturer's option, is your exclusive remedy. The manufacturer will return repaired or replacement products to you in working condition. You should expect the repair or replacement to take approximately 30 days.

3. How long is the limited warranty period?

The limited warranty period for the PRODUCT extends for ONE (1) YEAR from the date of purchase. If the manufacturer repairs or replaces a materially defective PRODUCT under the terms of this limited warranty, this limited warranty also applies to repaired or replacement PRODUCT for a period of either (a) 90 days from the date the repaired or replacement PRODUCT is shipped to you or (b) the time remaining on the original one-year limited warranty; whichever is longer.

Limited warranty

4. What is not covered by this limited warranty?

This limited warranty does not cover:

- ▶ PRODUCT that has been subjected to misuse, accident, shipping or other physical damage, improper installation, abnormal operation or handling, neglect, inundation, fire, water, or other liquid intrusion; or
- ▶ PRODUCT that has been damaged due to repair, alteration, or modification by anyone other than an authorized service representative of the manufacturer; or
- ▶ PRODUCT to the extent that the problem experienced is caused by signal conditions, network reliability or cable or antenna systems; or
- ▶ PRODUCT to the extent that the problem is caused by use with non-AT&T accessories; or
- ▶ PRODUCT whose warranty/quality stickers, PRODUCT serial number plates or electronic serial numbers have been removed, altered or rendered illegible; or
- ▶ PRODUCT purchased, used, serviced, or shipped for repair from outside the United States of America or Canada, or used for commercial or institutional purposes (including but not limited to products used for rental purposes); or
- ▶ PRODUCT returned without valid proof of purchase (see item 6 on the next page); or
- ▶ Charges for installation or setup, adjustment of customer controls, and installation or repair of systems outside the unit.

5. How do you get warranty service?

To obtain warranty service, visit our website at **www.telephones.att.com** or call **1 (800) 222-3111**. In Canada, dial **1 (866) 288-4268**.

For more detailed instructions, refer to the online Complete user's manual at **www.telephones.att.com/manuals**.

NOTE: Before calling for service, please review the user's manual; a check of the PRODUCT's controls and features may save you a service call.

Except as provided by applicable law, you assume the risk of loss or damage during transit and transportation and are responsible for delivery or handling charges incurred in the transport of the PRODUCT(s) to the service location. The manufacturer will return repaired or replaced PRODUCT under this limited warranty to you. Transportation, delivery or handling charges are prepaid. The manufacturer assumes no risk for damage or loss of the PRODUCT in transit. If the PRODUCT failure is not covered by this limited warranty, or proof of purchase does not meet the terms of this limited warranty, the manufacturer will notify you and will request that you authorize the cost of repair prior to any further repair activity. You must pay for the cost of repair and return shipping costs for the repair of products that are not covered by this limited warranty.

Limited warranty

6. What must you return with the **PRODUCT** to get warranty service?

You must:

- ▶ Return the entire original package and contents including the **PRODUCT** to the service location along with a description of the malfunction or difficulty; and
- ▶ Include a “valid proof of purchase” (sales receipt) identifying the **PRODUCT** purchased (**PRODUCT** model) and the date of purchase or receipt; and
- ▶ Provide your name, complete and correct mailing address, and telephone number.

7. Other limitations

This warranty is the complete and exclusive agreement between you and the manufacturer of this AT&T branded **PRODUCT**. It supersedes all other written or oral communications related to this **PRODUCT**. The manufacturer provides no other warranties for this **PRODUCT**. The warranty exclusively describes all of the manufacturer’s responsibilities regarding the **PRODUCT**. There are no other express warranties. No one is authorized to make modifications to this limited warranty and you should not rely on any such modification.

State/Provincial Law rights: This warranty gives you specific legal rights, and you may also have other rights which vary from state to state or province to province.

Limitations: Implied warranties, including those of fitness for a particular purpose and merchantability (an unwritten warranty that the **PRODUCT** is fit for ordinary use) are limited to one year from date of purchase. Some states/provinces do not allow limitations on how long an implied warranty lasts, so the limitation mentioned above may not apply to you. In no event shall the manufacturer be liable for any indirect, special, incidental, consequential, or similar damages (including, but not limited to lost profits or revenue, inability to use the **PRODUCT** or other associated equipment, the cost of substitute equipment, and claims by third parties) resulting from the use of this **PRODUCT**. Some states/provinces do not allow the exclusion or limitation of incidental or consequential damages, so the limitation or exclusion mentioned above may not apply to you.

Please retain your original sales receipt as proof of purchase.

Technical specifications

Operation	Operating time*
Talk time (cordless handset)	Up to 7 hours
Talk time (cordless handset speakerphone)	Up to 5 hours
Standby	Up to 5 days

* Operating times vary depending on your actual use and the age of the battery.

DECT 6.0 digital technology

The AT&T DECT 6.0 products offer unsurpassed range performance and sound clarity. This is achieved through a unique antenna design and advances in noise-filtering technology. An independent laboratory has confirmed that AT&T DECT 6.0 products perform up to 45% better in range competitions against similarly equipped phones of the leading competition. Now, calls can be taken in the basement, backyard and garage with exceptional sound quality.

Telephone operating range

This cordless telephone operates within the maximum power allowed by the Federal Communications Commission (FCC). Even so, this handset and telephone base can communicate only a certain distance — which can vary with the locations of the telephone base and handset, the weather, and the construction of your home or office.

Redefining long range coverage and clarity

This telephone base comes with an antenna which gives much better clarity and covers a longer range than before.

HD audio

HD audio improves sound quality by expanding and rebuilding frequencies that are lost with traditional phone calls. There is no additional telephone service requirement to use HD audio. It is designed to work with standard telephone service. Your system will automatically enhance all received sound with HD audio.

Simulated full-duplex handset and base speakerphones

The simulated full-duplex speakerphones on your handset and telephone base allow both ends of a call to speak and be heard at the same time. Optimal performance is subject to external factors and individual usage.

Index
Index

A

Allow list 58
Announcement 80
Answering system 80–95

B

Battery backup mode 12
Battery charging 10
Battery installation 9–10
Block list 53

C

Caller ID announce
 handset 16
Caller ID (CID)
 add entries to phone directory 44
 dial entries 44
 review entries 43
Charger installation 7, 8
Clear voicemail indication
 handset 18
 telephone base 25
Clock
 handset 15
 telephone base 22

D

Date and time
 handset 15
 telephone base 22
Delete
 a directory entry 40
Dialing
 from a record in the caller ID
 history 44
Directory
 edit entries 41
 name search 40
 new entries 39
DSL 7

E

Ending a call 27

H

Handset
 handset locator 33
 quick reference guide 1–3
 ringer tone 14
 ringer volume 14
 voicemail indicator 18
HD audio 116

I

Important safety information 105–107
Intercom 34–35

L

Last number redial 28
LCD language 16, 23
Limited warranty 113–115

M

Maintenance 104
Making calls 27
Message
 alert tone 86
 playback 91–94
Mute 29

N

Names
 enter into directory 39
 search 40
Number of rings 85

Index

O

Outgoing announcement 80

P

Paging tone 33
Power adapter 7
Push-to-talk 36–38

Q

Quick reference guide 1–6

R

Receiving calls 27
Recharging 10
Redial 28
Remote access 95
Ring tone options
 handset 14
 telephone base 21

S

Safety information 105–107
Smart call blocker 45–77
 allowed calls 70
 blocked calls 71
 customized settings 50–52
 screen calls without numbers 72
 screening announcement 66
 screen uncategorized calls 75
 Set profile 49–50
Speakerphone 27
Speed dial
 check voicemail 42
 make a call 42
 set voicemail number 17, 24
Star name list 63

T

Technical specifications 116
Telephone base
 quick reference guide 4–6
 ringer tone 21
 ringer volume 21
Time
 handset 15
 telephone base 22
Troubleshooting 98–103

U

Unwelcome calls 47

V

Visual message waiting indicator
 handset 17
 telephone base 24
Voice announce caller ID
 handset 16
Voice guide 11, 69, 84
Voice guide to set Answering
 system 84
Voice guide to set Smart call
 blocker 69
Voicemail 17, 88
 quick access 17, 24, 42
Volume control
 handset 14, 28, 91
 telephone base 21, 28, 91

W

Wall mount installation 13
Warranty 113–115
Welcome calls 47



For more detailed instructions, refer to the online Complete user's manual at www.telephones.att.com/manuals.

For customer service or product information, please visit our website at www.telephones.att.com or call 1 (800) 222-3111. In Canada, dial 1 (866) 288-4268.

© 2018 Advanced American Telephones. All Rights Reserved.

Qaltel™ is a trademark of Truecall Group Limited.

AT&T and the AT&T logo are trademarks of AT&T Intellectual Property licensed to Advanced American Telephones, San Antonio, TX 78219.

RBRC® and 1-800-8-BATTERY® are registered trademarks of the Rechargeable Battery Recycling Corporation.

Printed in China. Issue 1.0 AT&T 12/18.