

CS6719-X ENGRAVING FFILE

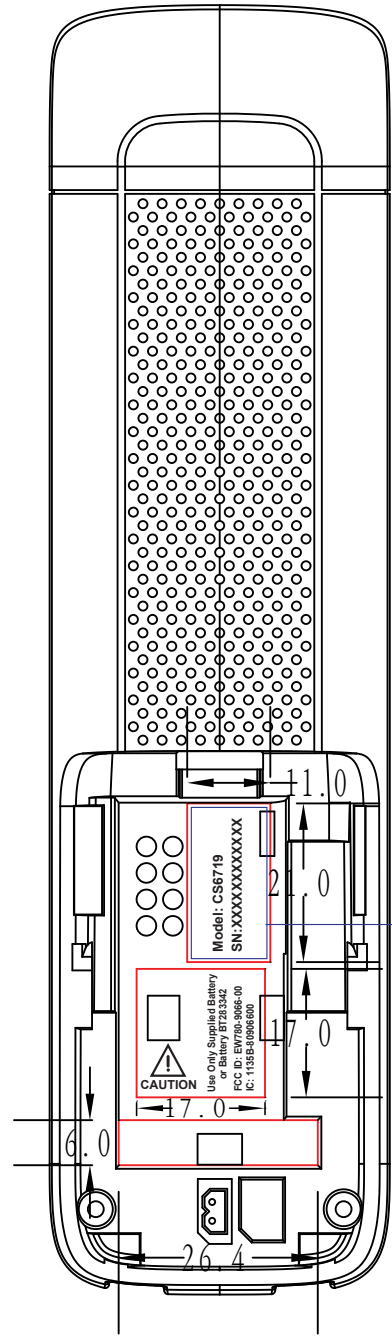

HS

- Model: CS6719
S/N: XXXXXXXXXXXXXXXXXXXX
- Model: CS6719-15
S/N: XXXXXXXXXXXXXXXXXXXX
- Model: CS6719-16
S/N: XXXXXXXXXXXXXXXXXXXX
- Model: CS6719-2
S/N: XXXXXXXXXXXXXXXXXXXX
- Model: CS6719-3
S/N: XXXXXXXXXXXXXXXXXXXX
- Model: CS6719-4
S/N: XXXXXXXXXXXXXXXXXXXX
- Model: CS6719-5
S/N: XXXXXXXXXXXXXXXXXXXX

**SN LABEL
28X10mm**

- Model: CS6709
SN:XXXXXXXXXXXX
- Model: CS6719
SN:XXXXXXXXXXXX
- Model: CS6719-15
SN:XXXXXXXXXXXX
- Model: CS6719-16
SN:XXXXXXXXXXXX
- Model: CS6719-2
SN:XXXXXXXXXXXX
- Model: CS6719-3
SN:XXXXXXXXXXXX
- Model: CS6719-4
SN:XXXXXXXXXXXX
- Model: CS6719-5
SN:XXXXXXXXXXXX

**SN LABEL
20X10mm**

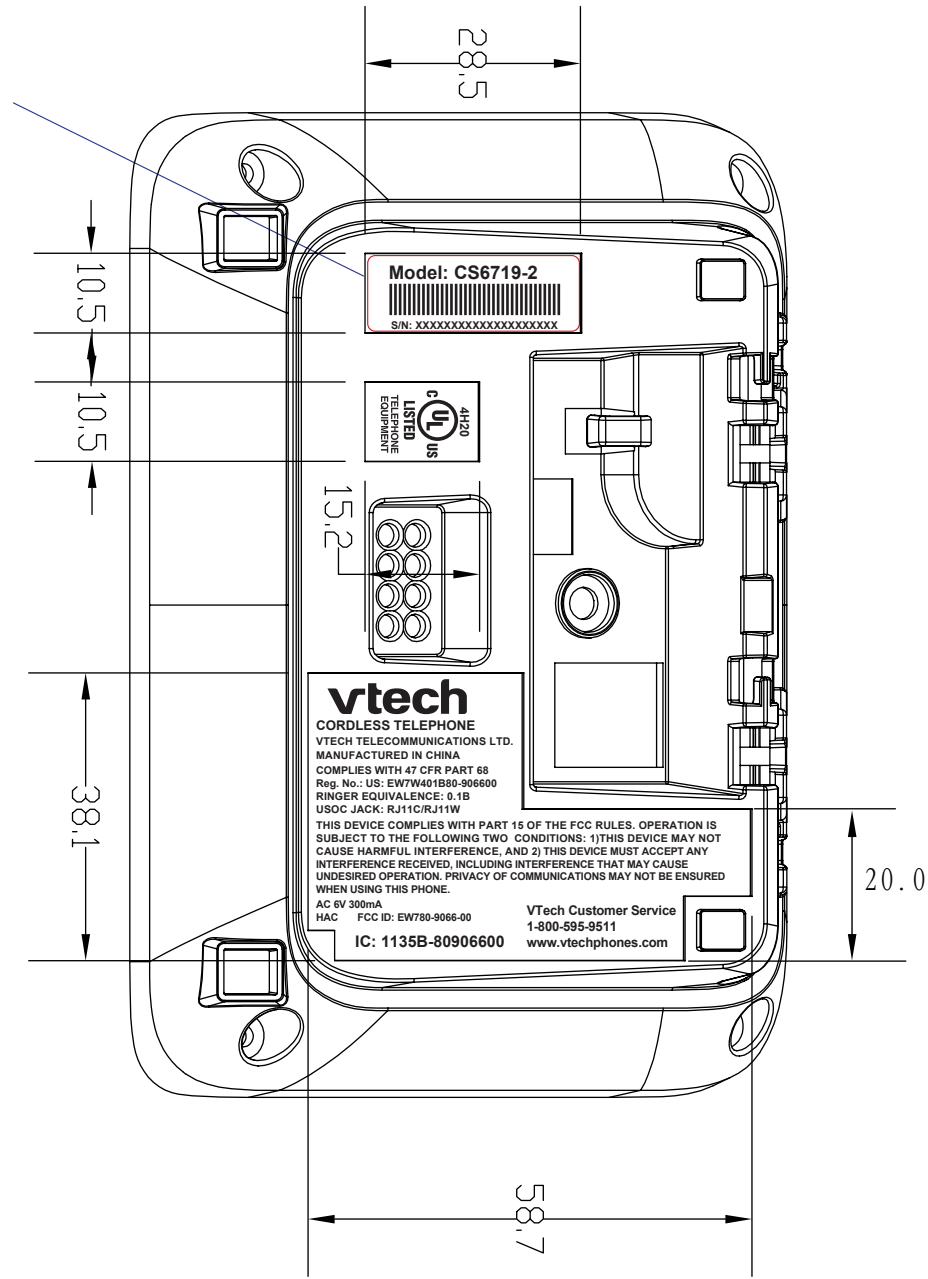

BS

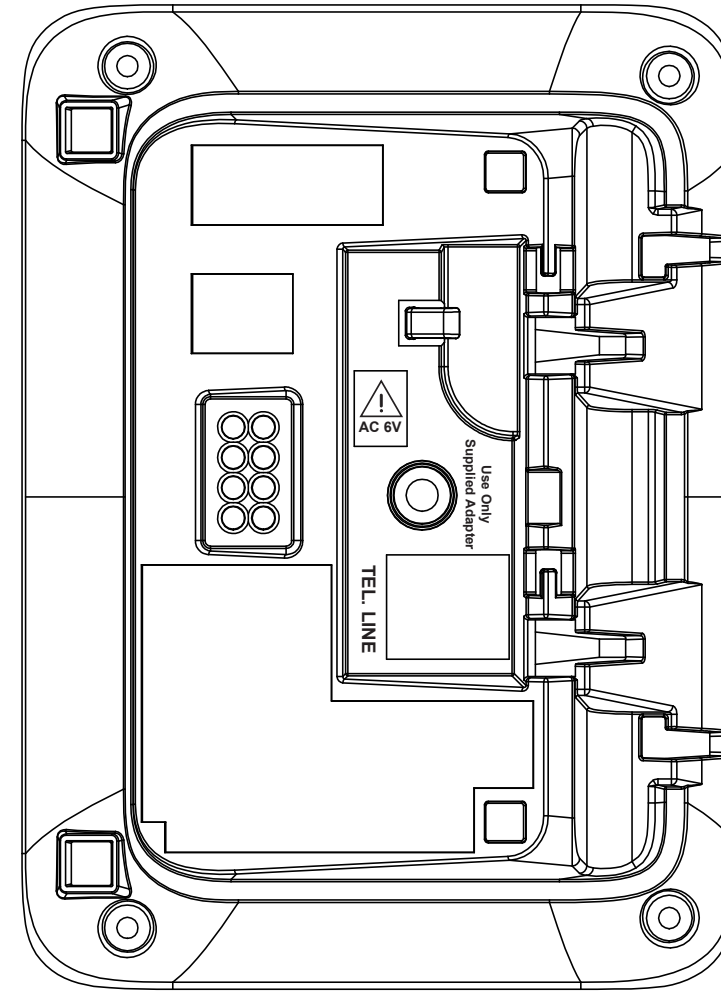

CHARGER

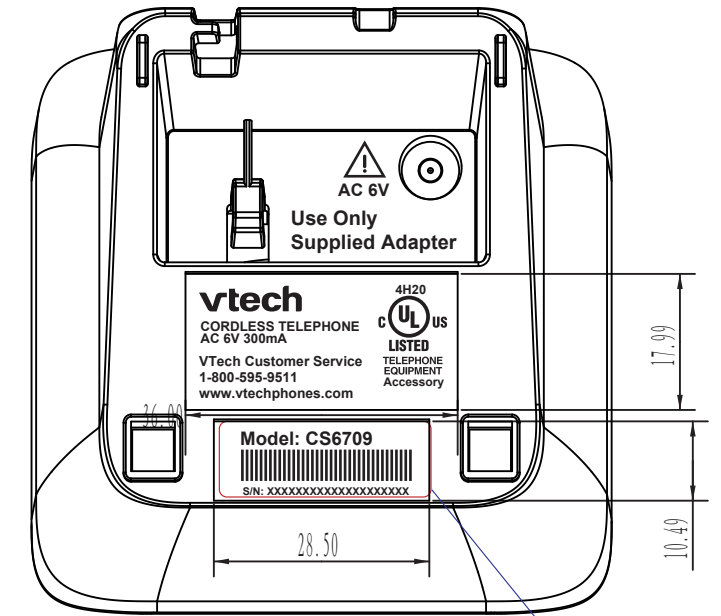

- Model: CS6709
S/N: XXXXXXXXXXXXXXXXXXXX

**SN LABEL
28X10mm**

CS6729-X ENGRAVING FFILE

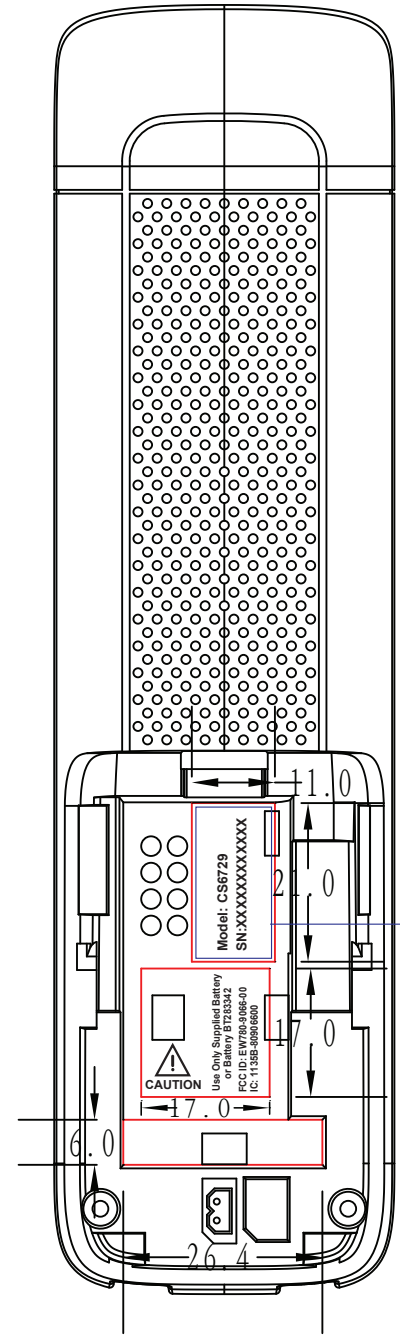

HS

Model: CS6729	SN:XXXXXXXXXXXXXX
Model: CS6729-2	SN:XXXXXXXXXXXXXX
Model: CS6729-3	SN:XXXXXXXXXXXXXX
Model: CS6729-4	SN:XXXXXXXXXXXXXX
Model: CS6729-5	SN:XXXXXXXXXXXXXX

SN LABEL
20X10mm

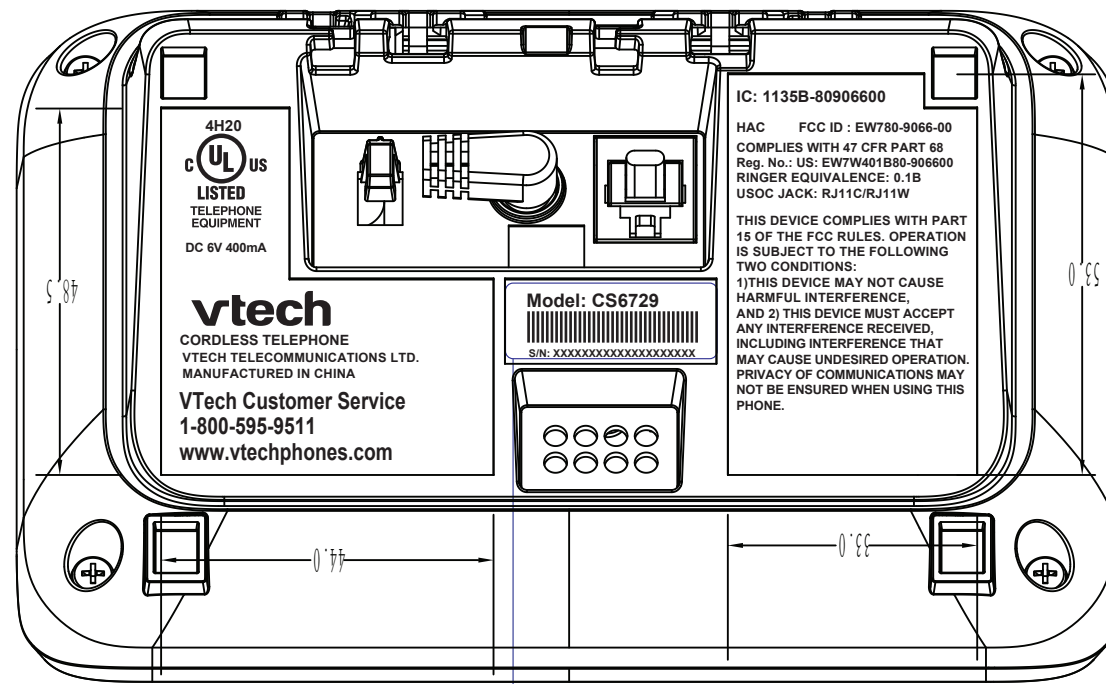
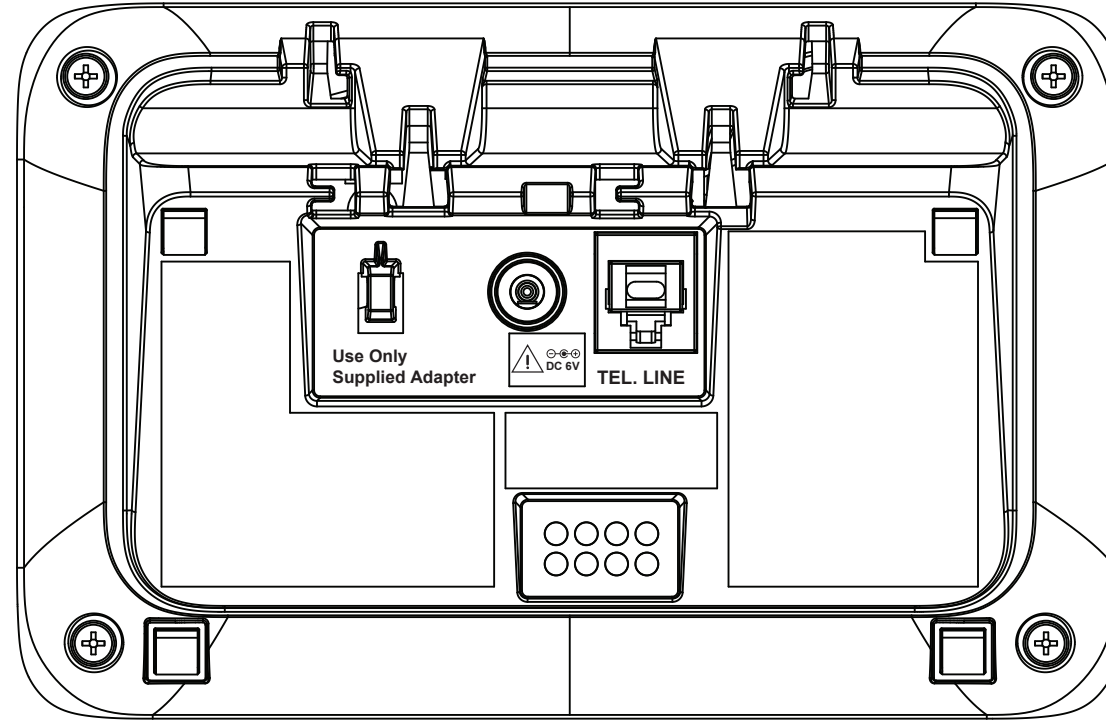

BS

Model: CS6729	SN:XXXXXXXXXXXXXX
Model: CS6729-2	SN:XXXXXXXXXXXXXX
Model: CS6729-3	SN:XXXXXXXXXXXXXX
Model: CS6729-4	SN:XXXXXXXXXXXXXX
Model: CS6729-5	SN:XXXXXXXXXXXXXX

SN LABEL
28X10mm

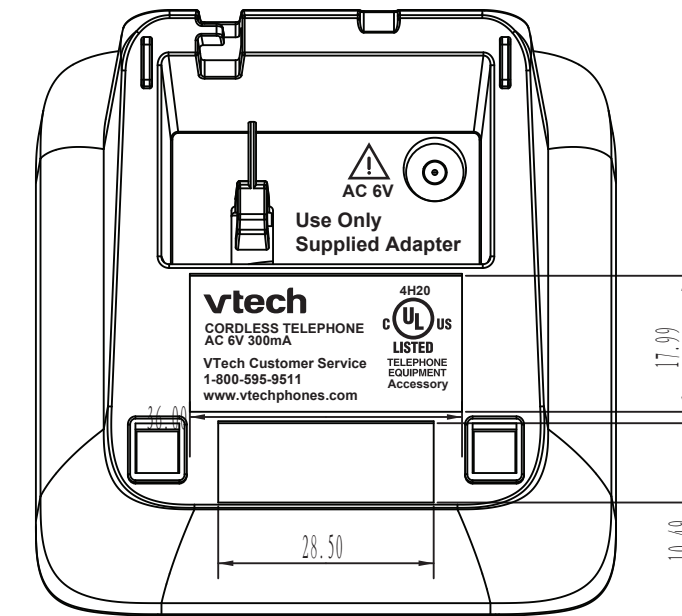

CHARGER

CS6829-X ENGRAVING FFILE

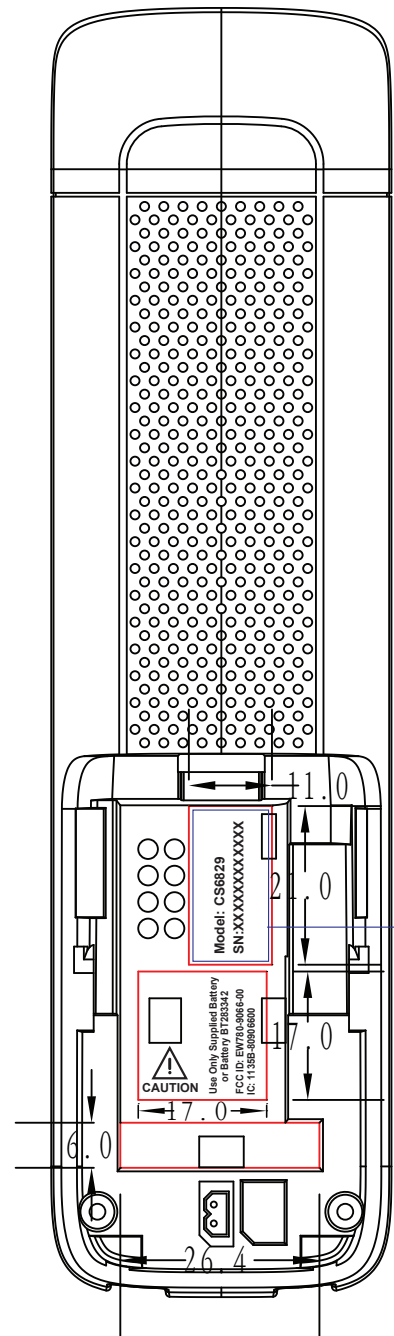

HS

Model: CS6829
SN:XXXXXXXXXXXX

Model: CS6829-2
SN:XXXXXXXXXXXX

Model: CS6829-3
SN:XXXXXXXXXXXX

Model: CS6829-4
SN:XXXXXXXXXXXX

SN LABEL
20X10mm

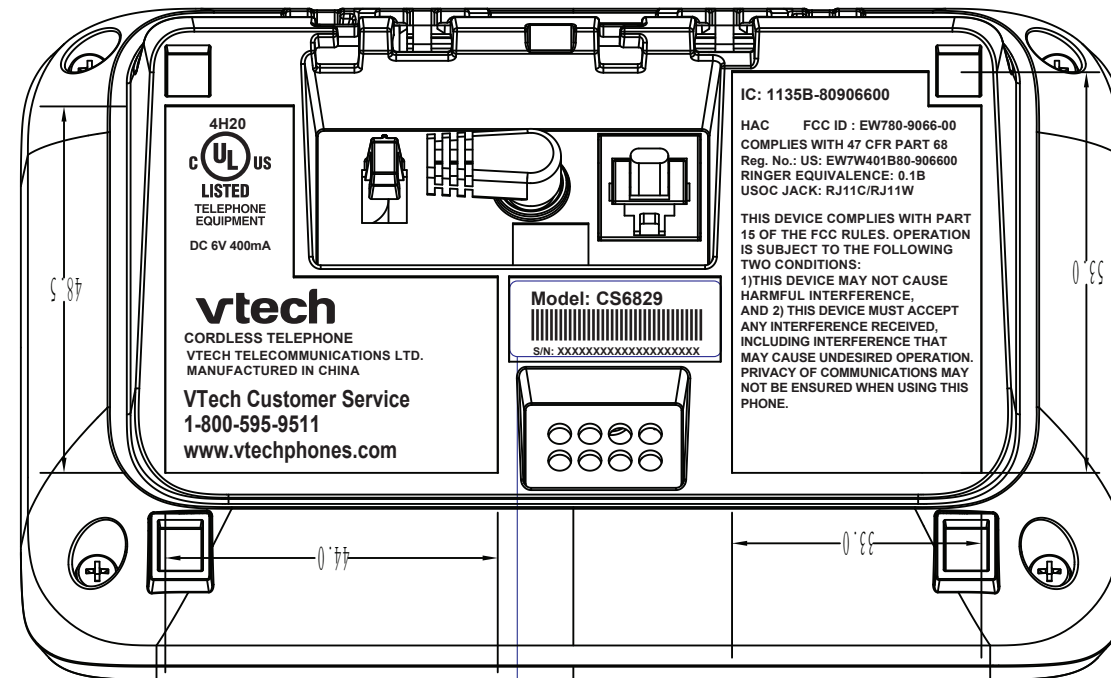
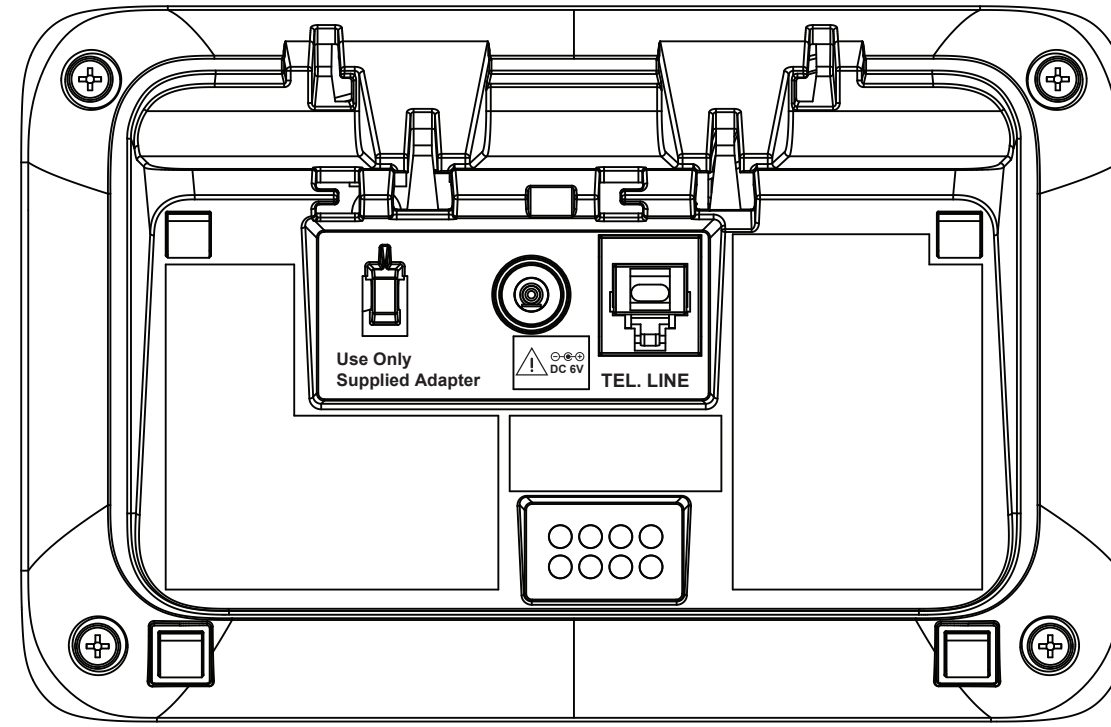

BS

Model: CS6829
SN:XXXXXXXXXXXX

Model: CS6829-2
SN:XXXXXXXXXXXX

Model: CS6829-3
SN:XXXXXXXXXXXX

Model: CS6829-4
SN:XXXXXXXXXXXX

SN LABEL
28X10mm

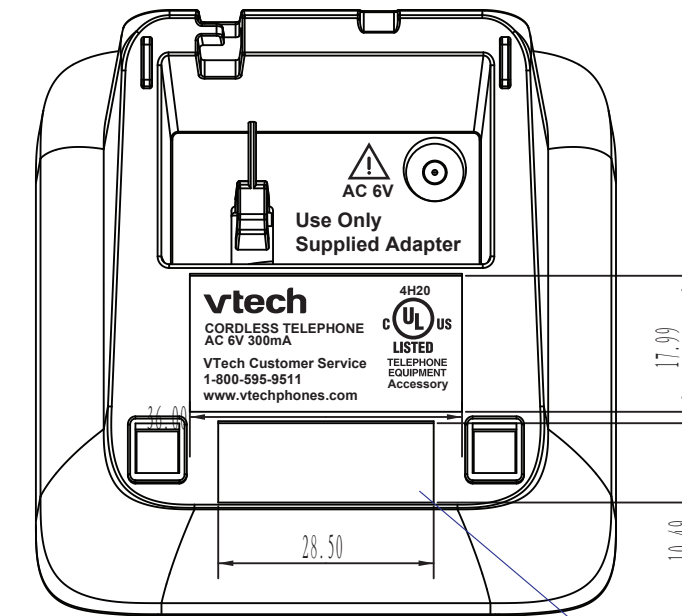

CHARGER

SN LABEL
28X10mm