

TEST REPORT

Report Number: 20100726HKG-001

Application For Class II Permissive Change of 47 CFR Part 15 Certification
Class II Permissive Change of RSS-213 Issue 3 Equipment Certification

Unlicensed Personal Communication Service Devices/
2 GHz License-exempt Personal Communications Service Devices

(Base Unit)

FCC ID: EW780-8015-04

IC: 1135B-80801504

Prepared and Checked by:

Approved by:

Signed On File
Leung Chiu Kuen, Stanley
Engineer

Tang Kwan Mo, Jess
Lead Engineer
Date: December 01, 2020

TEST REPORT

GENERAL INFORMATION

Grantee:	VTech Telecommunications Ltd.
Grantee Address:	23/F., Tai Ping Industrial Centre, Block 1, 57 Ting Kok Road, Tai Po, Hong Kong.
FCC Specification Standard:	FCC Part 15, October 1, 2019 Edition
FCC ID:	EW780-8015-04
FCC Model(s):	CS6124 C, CS6124, CS6124-11, CS6124-2, CS6124-21, CS6120-2, CS6120-31, CS6124-31, CS612Z-XY, CS6124-11 C, CS6124-2 C, CS6124-21 C, CS6120-2 C, CS6120-31 C, CS6124-31 C, CS612Z-XY C, VA17241BK
IC Specification Standard:	RSS-213 Issue 3, March 2015 RSS-Gen Issue 5, April 2018
IC:	1135B-80801504
HVIN:	35-201552BS
VTech Model(s):	CS6124 C, CS6124-11 C, CS6124-2 C, CS6124-21 C, CS6124-31 C
PMN:	CS6124, CS6124-11, CS6124-2, CS6124-21, CS6124-31
Type of EUT:	Unlicensed Personal Communications Service Devices
Description of EUT:	DECT 6.0 Cordless Telephone - Base Unit
Serial Number:	N/A
Sample Receipt Date:	October 21, 2020
Date of Test:	October 23 - November 01, 2020
Report Date:	December 01, 2020
Environmental Conditions:	Temperature: +10 to 40°C Humidity: 10 to 90%
Conclusion:	Test was conducted by client submitted sample. The submitted sample as received complied with the 47 CFR Part 15 / RSS-213 Issue 3 Certification.

TEST REPORT

TABLE OF CONTENTS

1.0 TEST RESULTS SUMMARY & STATEMENT OF COMPLIANCE 4

 1.1 Summary of Test Results4

 1.2 Statement of Compliance4

2.0 GENERAL DESCRIPTION 5

 2.1 Product Description.....5

 2.2 Purpose of Change5

 2.3 Test Methodology5

 2.4 Test Facility5

3.0 SYSTEM TEST CONFIGURATION 6

 3.1 Justification6

 3.2 Radiated Emission Test Setup7

 3.3 AC Line Conducted Emission Test Setup.....8

 3.4 Conducted Emission Test Configuration.....9

 3.5 Conducted Monitoring and Operational Test Configuration9

 3.6 EUT Exercising Software9

 3.7 Details of EUT and Description of Accessories.....10

 3.8 Measurement Uncertainty10

4.0 MEASUREMENT RESULTS 11

 4.1 Emission Bandwidth11

 4.2 Power Spectral Density13

 4.3 Unwanted Emission Inside the Sub-Band15

 4.4 Emissions Outside the Sub-Band18

 4.4.1 Radiated Emissions Configuration Photographs19

 4.4.2 Radiated Emissions Data19

 4.4.3 Field Strength Calculation.....25

 4.4.4 Average Factor Calculation and Transmitter ON Time Measurements.....26

 4.5 AC Power Line Conducted Emissions.....27

 4.5.1 AC Power Line Conducted Emissions Configuration Photographs28

 4.5.2 AC Power Line Conducted Emissions Data28

5.0 EQUIPMENT LIST 35

TEST REPORT

1.0 TEST RESULTS SUMMARY & STATEMENT OF COMPLIANCE

1.1 Summary of Test Results

General Technical Requirements					
Test Items	RSS-213 / RSS-Gen# Clause	FCC Part 15 Section	Test Procedure ANSI C63.17 / ANSI C63.4*	Results	Details See Section
Occupied/Emission Bandwidth	5.5	15.323(a)	6.1.3	Pass	4.1
Power Spectral Density	5.7	15.319(d)	6.1.5	Pass	4.2
Unwanted Emission Inside the Sub-Band	5.8.2	15.323(d)	6.1.6.1	Pass	4.3
AC Power Line Conducted Emissions from EUT	5.4	15.315	7 *	Pass	4.5

Specific Requirements for UPCS Device					
Test Items	RSS-213 Clause	FCC Part 15 Section	Test Procedure ANSI C63.17	Results	Details See Section
Emissions Outside the Sub- Band	5.8.1	15.323(d)	6.1.6.2	Pass	4.4

1.2 Statement of Compliance

The equipment under test is found to be complying with the following standards:

FCC Part 15, October 1, 2019 Edition
RSS-213 Issue 3, March 2015
RSS-Gen Issue 5, April 2018

TEST REPORT

2.0 GENERAL DESCRIPTION

2.1 Product Description

The CS6124 C (35-201552BS) is a DECT 6.0 Cordless Telephone - Base Unit. It operates at frequency range of 1921.536MHz to 1928.448MHz with 5 channels (1921.536MHz, 1923.264MHz, 1924.992MHz, 1926.720MHz and 1928.448MHz). The Base Unit is powered by an adaptor 100-120VAC 60Hz 150mA.

The antenna used in base unit are integral, and the test sample is a prototype.

For FCC, the Model(s): CS6124, CS6124-11, CS6124-2, CS6124-21, CS6120-2, CS6120-31, CS6124-31, CS612Z-XY, CS6124-11 C, CS6124-2 C, CS6124-21 C, CS6120-2 C, CS6120-31 C, CS6124-31 C, CS612Z-XY C and VA17241BK are the same as the Model: CS6124 C in electrical designs including software & firmware, PCB layout and construction design/physical design/enclosure as declared by client. The only differences between these models are color, model number and packing size/material to be sold for marketing purpose as declared by client. CS6120 series and CS6124 series are identical except different packing. CS6120 series is bigger size giftbox than CS6124 series (standard giftbox size) as declared by client. Suffix ("X, Y, Z") indicates different number of handsets and extra chargers, different color of enclosure, and different package material as declared by client.

Connection between the device and the telephone network is accomplished through the use of USOC RJ11C in the 2-wire loop calling central office line.

2.2 Purpose of Change

The purpose of change is saved with filename: product change.pdf

2.3 Test Methodology

The radiated emission measurements for unintentional radiator (if any) and AC power line-conducted emission measurements were performed according to the test procedures specified in ANSI C63.4 (2014). The radiated emission measurements for intentional radiator contained in UPCS device, conducted emission measurements, Listen Before Transmit (LBT) tests, Time Frame and Frequency Stability tests were performed according to the test procedures specified in ANSI C63.17 (2013). All radiated measurements were performed in radiated emission test site. Preliminary scans were performed in the radiated emission test site only to determine worst case modes. All radiated tests were performed at an antenna to EUT distance of 3 meters, unless stated otherwise in the "Justification Section" of this Application. All other measurements were made in accordance with the procedures in 47 CFR Part 2 / RSS-Gen Issue 5 (2018).

2.4 Test Facility

The radiated emission test site, AC power line conducted measurement facility and antenna port conducted measurement facility used to collect the radiated data, AC Power Line conducted data, and conductive data are at Intertek Testing Services Hong Kong Ltd., which is located at Workshop No. 3, G/F., World-Wide Industrial Centre, 43-47 Shan Mei Street, Fo Tan, Sha Tin, N.T., Hong Kong SAR, China. This test facility and site measurement data have been fully placed on file with FCC and Industry Canada.

TEST REPORT

3.0 SYSTEM TEST CONFIGURATION

3.1 Justification

For emissions testing, the equipment under test (EUT) was set up to transmit continuously in burst mode with pseudo-random data to simplify the measurement methodology. Care was taken to ensure proper power supply voltages during testing. During testing, all cables (if any) were manipulated to produce worst-case emissions.

The Base Unit was powered by a 100-120VAC 60Hz 150mA to 6.0VDC 400mA adaptor.

For the measurements, the EUT was attached to a plastic stand if necessary and placed on the wooden turntable. If the EUT is attached to accessories, they were connected and operational (as typical as possible).

The signal was maximized through rotation and placement in the three orthogonal axes. The antenna height and polarization were varied during the search for maximum signal level. The antenna height was varied from 1 to 4 meters. Detector function was in peak mode. Radiated emissions are taken at three meters unless the signal level was too low for measurement at that distance. If necessary, a pre-amplifier was used and/or the test was conducted at a closer distance.

For UPCS transmitter radiated measurement, the spectrum analyzer resolution bandwidth was approximately 1% of EUT emission bandwidth, unless otherwise specified.

Radiated emission measurements for UPCS transmitter were performed from the lowest radio frequency signal generated in the device which is greater than 9 kHz to the tenth harmonic of the highest fundamental frequency or to 40 GHz, whichever is lower.

RF module for base unit of CS6124 C is the same with original granted model CS6114. Therefore conducted emission measurement for peak transmit power, jitter, frame repetition stability, carrier stability and listen before transmit requirements (except the monitoring threshold) for CS6124 C are skipped.

As the base unit has 2 antennas, both have been checked. While conducting the test on one of antennas, another one was being disable its transmission. The data in this report represented the worst-case.

For AC line conducted emission test, the EUT along with its peripherals were placed on a 1.0m(W)x1.5m(L) and 0.8m in height wooden table and the EUT was adjusted to maintain a 0.4 meter space from a vertical reference plane. The EUT was connected to power mains through a line impedance stabilization network (LISN), which provided 50ohm coupling impedance for measuring instrument. The LISN housing, measuring instrument case, reference ground plane, and vertical ground plane were bounded together. The excess power cable between the EUT and the LISN was bundled.

All connecting cables of EUT and peripherals were manipulated to find the maximum emission.

All relevant operation modes and different type of adaptors have been tested, and the worst case data is included in this report.

TEST REPORT

3.2 Radiated Emission Test Setup

The figure below shows the test setup, which is utilized to make these measurements.

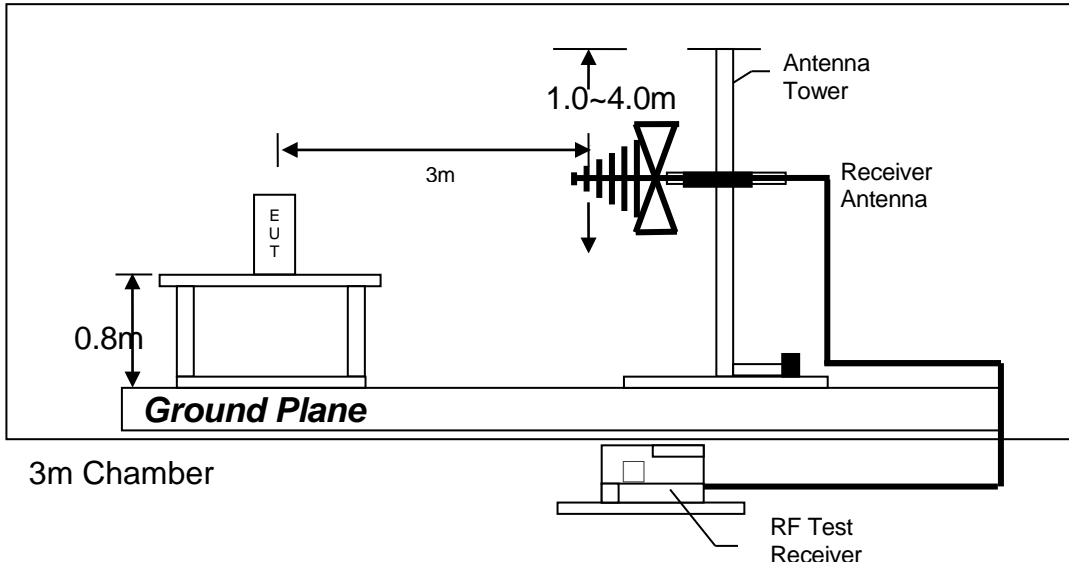

Test setup of radiated emissions up to 1GHz

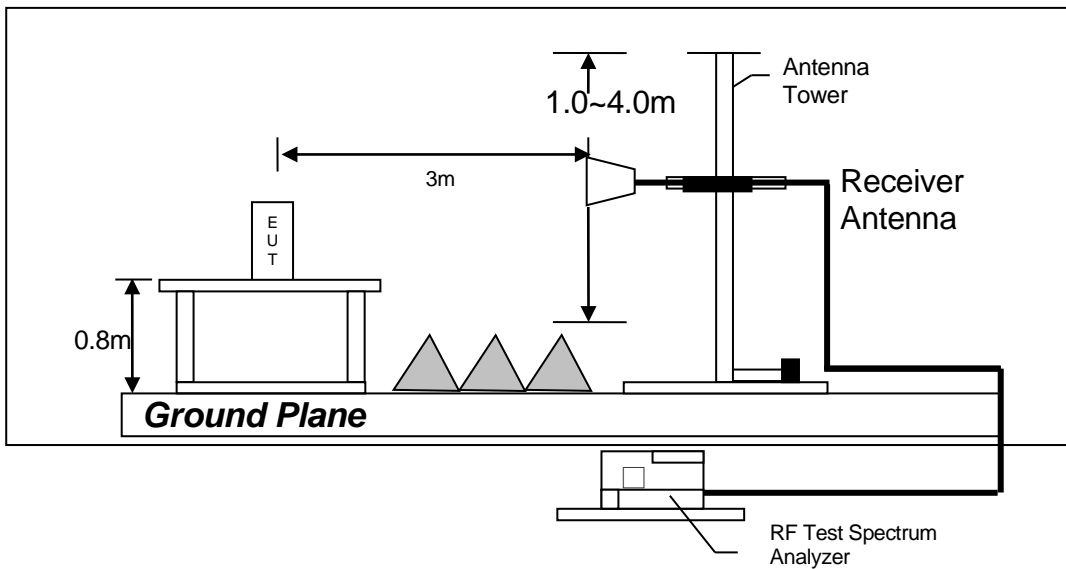

Test setup of radiated emissions above 1GHz

Figure 3.2.1

TEST REPORT

3.3 AC Line Conducted Emission Test Setup

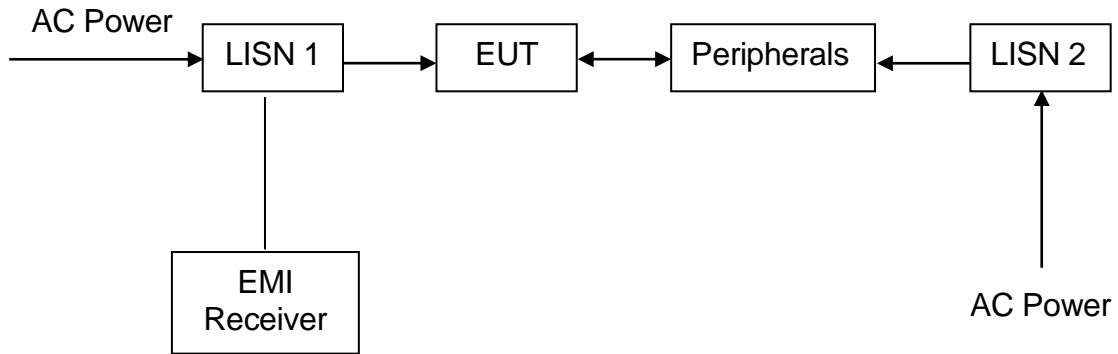

Figure 3.3.1

TEST REPORT

3.4 Conducted Emission Test Configuration

The setup and equipment setting were made in accordance with ANSI C63.17. The antenna of EUT transmitter was replaced by a coaxial cable. The impedance matching of connection, cable loss and external RF attenuator are taken into account. The EUT was arranged to communicate via a fixed carrier frequency between its transmitter and a companion device. The transmission was configured in burst mode with pseudo-random data as typical as normal operation.

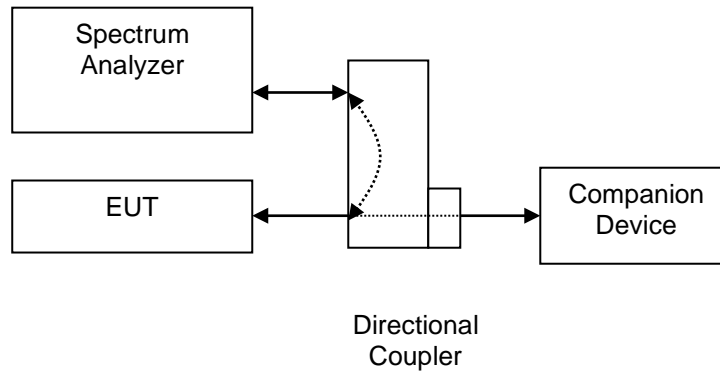

Figure 3.4.1

3.5 Conducted Monitoring and Operation Test Configuration

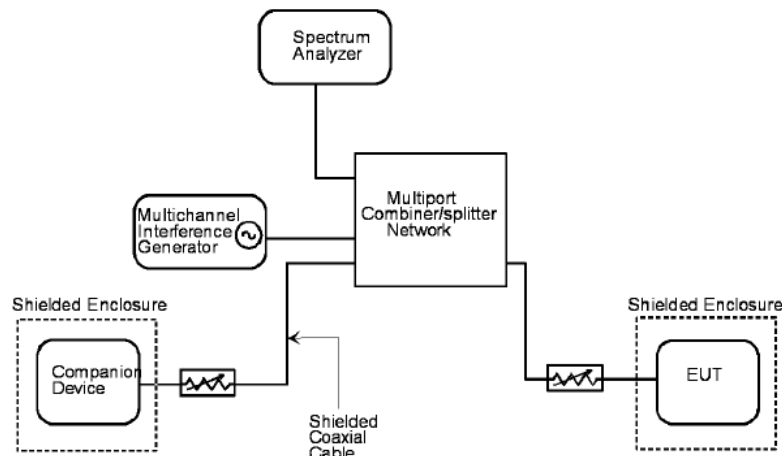

Figure 3.5.1

3.6 EUT Exercising Software

The EUT exercise program (if any) used during radiated and conducted testing was designed to exercise the various system components in a manner similar to a typical use.

TEST REPORT

3.7 Details of EUT and Description of Accessories

Details of EUT:

AC adaptor (provided with the unit) were used to power the device. Their descriptions are listed below.

- (1) AC adaptor (100-120VAC 60Hz 150mA to 6.0VDC 400mA, Model: S003AKU0600040, Brand: Ten Pao) (Supplied by Client)
- (2) AC adaptor (100-120VAC 60Hz 150mA to 6.0VDC 400mA, Model: VT05UUS06040, Brand: VTPL) (Supplied by Client)
- (3) AC adaptor (100-120VAC 60Hz 150mA to 6.0VDC 400mA, Model: A318-060040W-US1, Brand: Ao Hai) (Supplied by Client)

Description of Accessories:

- (1) Telecommunication cable with RJ11C connectors (1m, unshielded), terminated (Supplied by Intertek)
- (2) Handset, Model: CS6114, FCC ID: EW780-0815-03 (Supplied by Client)

3.8 Measurement Uncertainty

Decision Rule for compliance: For FCC/IC standard, the measured value must be within the limits of applicable standard without accounting for the measurement uncertainty. For EN/IEC/HKTA/HKTC standard, conformity rules will be used as per standard directly excepted EN/IEC 61000-3-2, EN/IEC 61000-3-3, HKTA1004, HKCA1008, HKTA1019, HKTA1020, HKTA1041 and HKTA1044. For these excepted or not mentioned standards, Cl 4.2.2 of ILAC-G8:09/2019 decision rules will be reference and guard band will be equal to our measurement uncertainty with 95% confidence level ($k=2$). In case, the measured value is within guard band region, undetermined decision will be used. The values of the Measurement uncertainty for radiated emission test, AC line conducted emission test and RF conducted test, frequency stability and timing jitter are $\pm 5.3\text{dB}$, $\pm 4.2\text{dB}$, $\pm 1\text{dB}$, $\pm 23\text{Hz}$, $0.1\mu\text{s}$ respectively.

Uncertainty and Compliance - Unless the standard specifically states that measured values are to be extended by the measurement uncertainty in determining compliance, all compliance determinations are based on the actual measured value.

TEST REPORT

4.0 MEASUREMENT RESULTS

4.1 Emission Bandwidth, FCC Rule 15.323(a) / RSS-213 Clause 5.5:

Operation shall be contained within the 1920 – 1930 MHz band. The emission bandwidth (*B*) shall be less than 2.5 MHz and greater than 50 kHz.

Measurements are made in accordance with ANSI C63.17 sub-clause 6.1.3 and RSS-Gen clause 4.6.1. Test setup is shown in section 3.4 Figure 3.4.1.

Test Results:

I. Base unit - Traffic Carrier

Channel	Channel Frequency (MHz)	Measuring Signal Level	Measured Emission Bandwidth (MHz)	Results
Lowest	1921.536	26 dB down	1.47	Pass
Highest	1928.448	26 dB down	1.47	Pass

The plots of emission bandwidth are saved as below.

TEST REPORT

PLOTS OF EMISSION BANDWIDTH

Base unit, Lowest channel, Traffic carrier

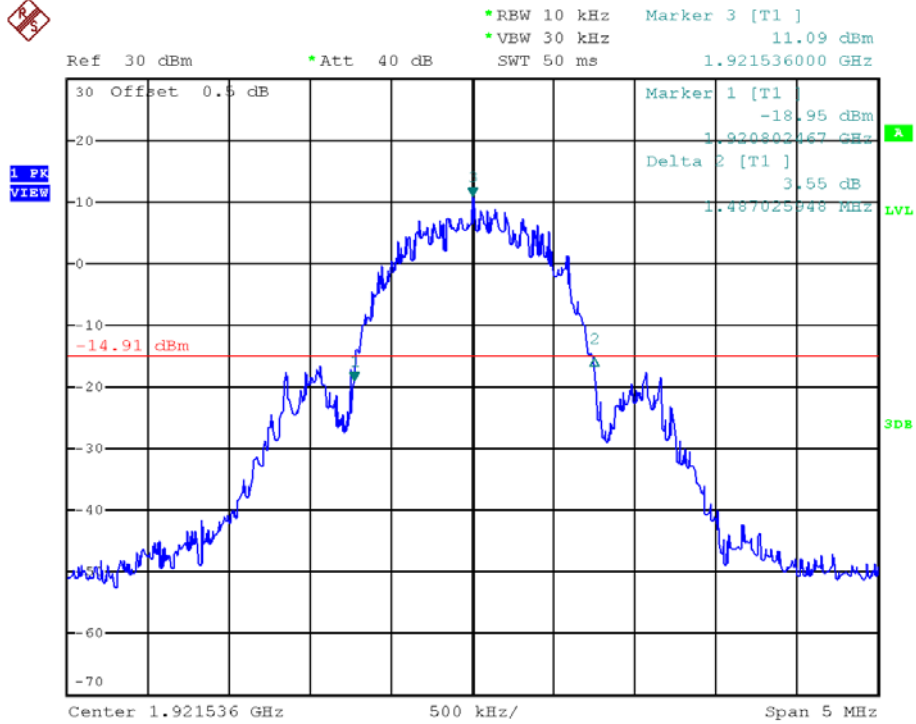

Base unit, Highest channel, Traffic carrier

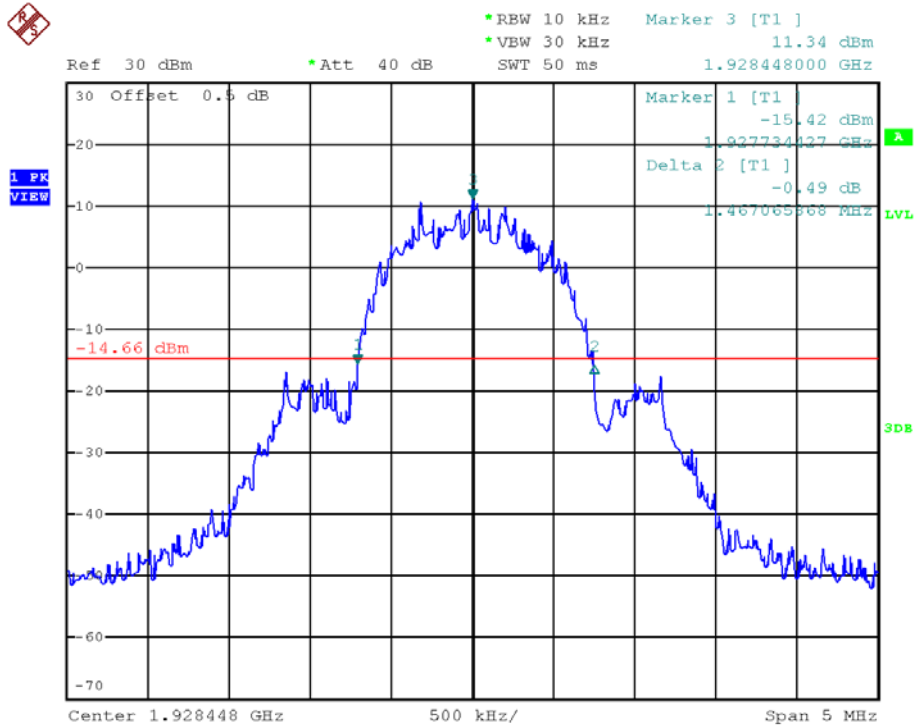

TEST REPORT

4.2 Power Spectral Density, FCC Rule 15.319(d) / RSS-213 Clause 5.7:

Power spectral density shall not exceed 3 mW (4.8dBm) in any 3 kHz bandwidth as measured with a spectrum analyzer having a resolution bandwidth of 3 kHz.

Measurements are made in accordance with ANSI C63.17 sub-clause 6.1.5. Test setup is shown in section 3.4 Figure 3.4.1.

Test Results:

I. Base unit - Traffic Carrier

Channel	Channel Frequency (MHz)	Measured Power Spectral Density (dBm/3kHz)	Limit (dBm/3 kHz)	Results
Lowest	1921.536	-5.3	4.8	Pass
Highest	1928.448	-4.5	4.8	Pass

The plots of the power spectral density are as below.

TEST REPORT

PLOTS OF THE POWER SPECTRAL DENSITY

Base unit, Lowest channel, Traffic carrier

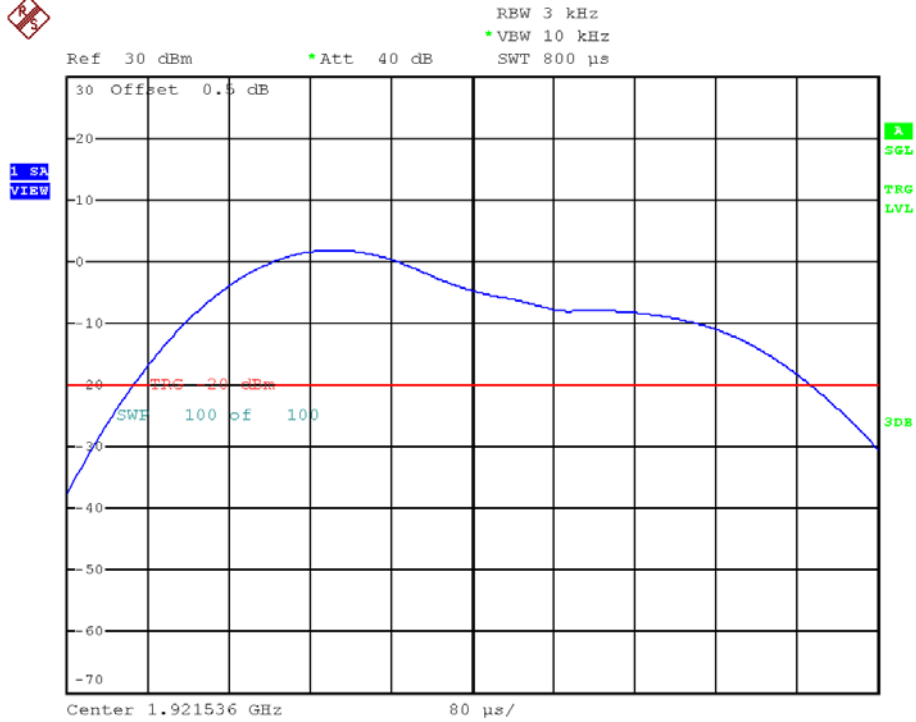

Base unit, Highest channel, Traffic carrier

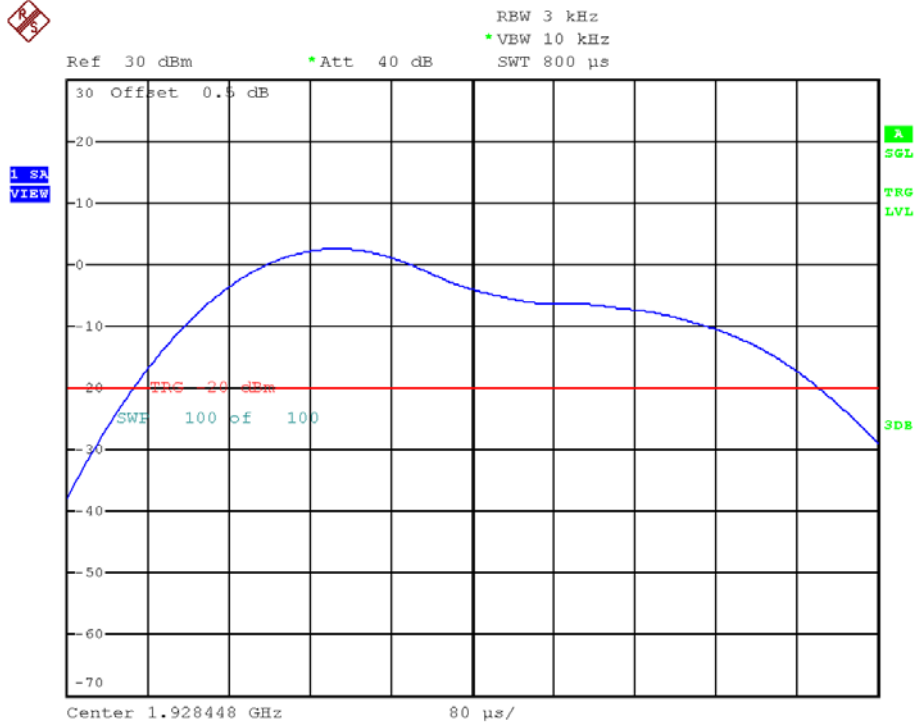

TEST REPORT

4.3 Unwanted Emission Inside the Sub-Band, FCC Rule 15.323(d) /
RSS-213 Clause 5.8.2:

Emissions inside the sub-band must comply with the following emission mask:

1. In the bands between $1B$ and $2B$ measured from the center of the emission bandwidth, emission shall be at least 30 dB below the permitted peak transmit power.
2. In the bands between $2B$ and $3B$ measured from the center of the emission bandwidth, emission shall be at least 50 dB below the permitted peak transmit power.
3. In the bands between $3B$ and the band edge, emission shall be at least 60 dB below the permitted peak transmit power.

Where B = emission bandwidth in Hz

Measurements are made in accordance with ANSI C63.17 sub-clause 6.1.6.1. Test setup is shown in section 3.4 Figure 3.4.1

Test Results:

I. Base unit - Traffic Carrier

Channel	Channel Frequency (MHz)	Results
Lowest	1921.536	Pass
Middle	1924.992	Pass
Highest	1928.448	Pass

The plots of the unwanted emission inside the sub-band are as below.

TEST REPORT

Plots of the unwanted emission inside the sub-band

Base unit, Lowest channel, Traffic carrier

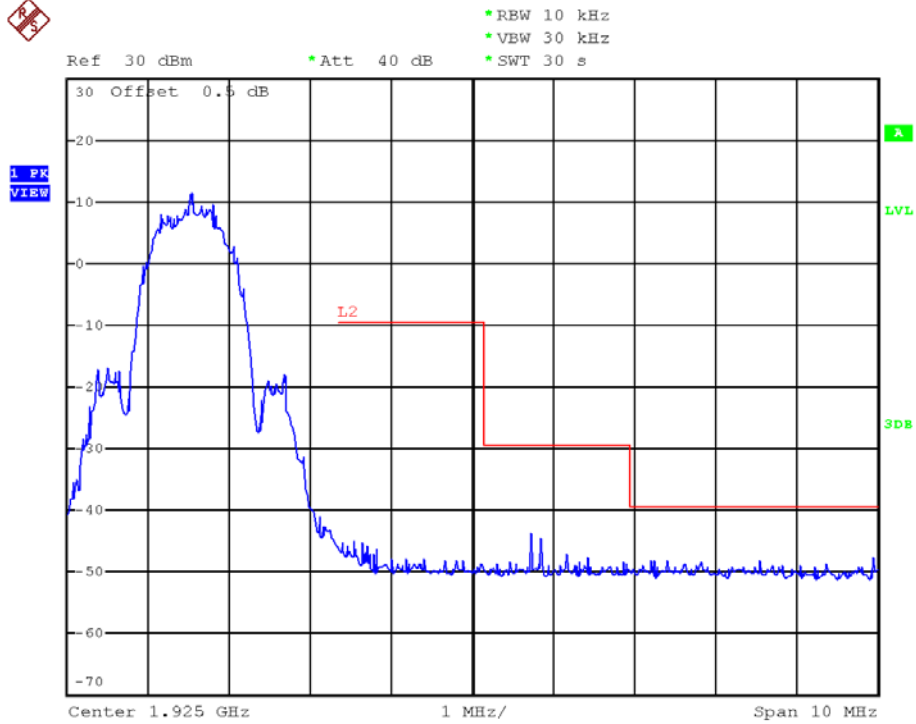

Base unit, Middle channel, Traffic carrier

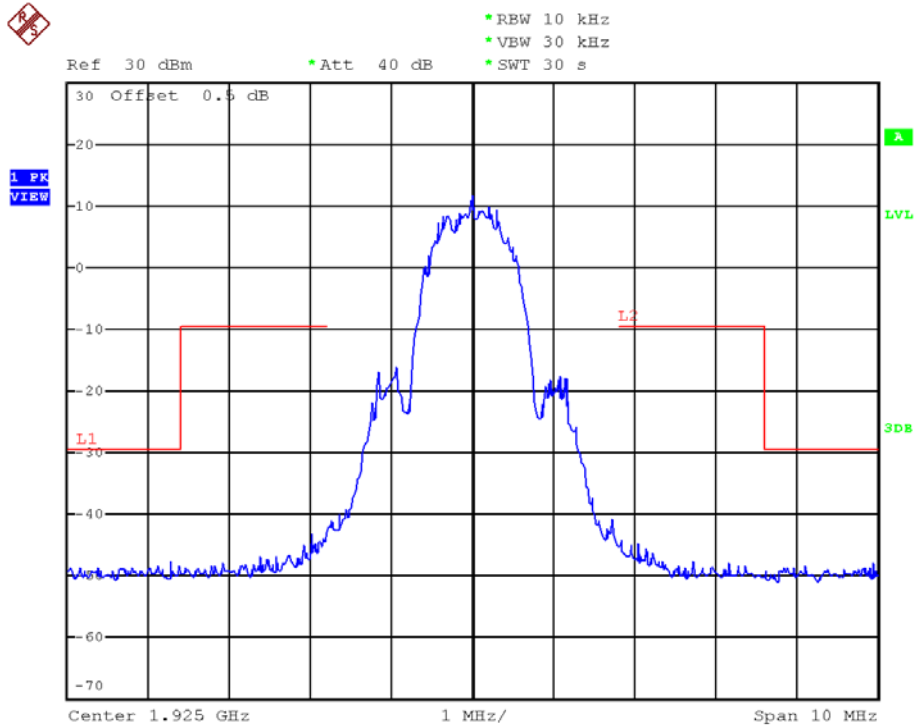

TEST REPORT

Plots of the unwanted emission inside the sub-band

Base unit, Highest channel, Traffic carrier

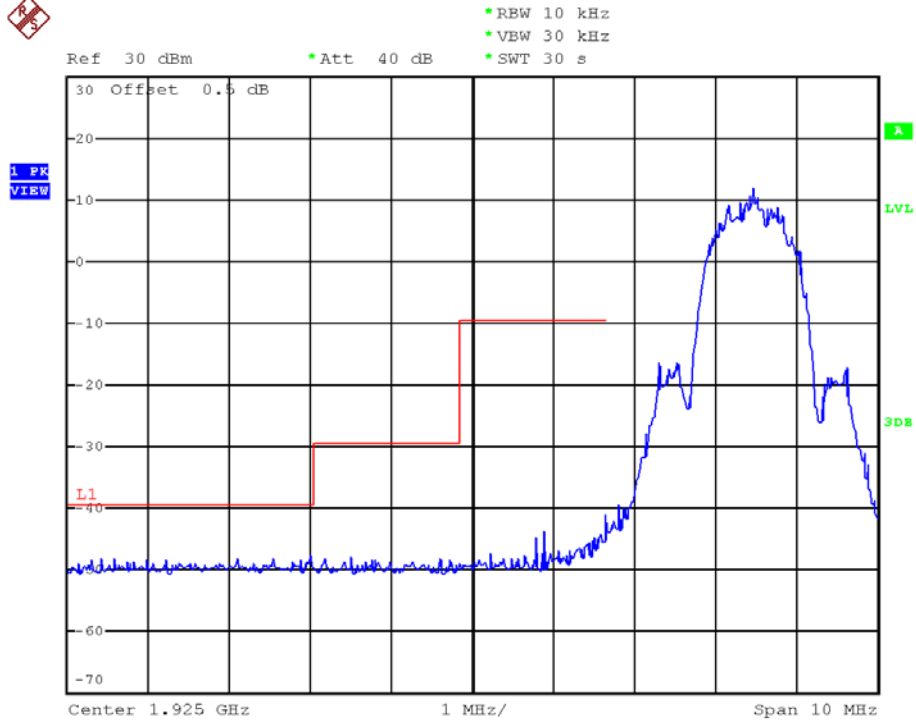

TEST REPORT

4.4 Emissions Outside the Sub-Band, FCC Rule 15.323(d) / RSS-213 Clause 5.8.1:

Emissions outside the sub-band shall be attenuated below a reference power of 112 mW (20.5 dBm) as follows:

1. 30 dB between the band edge and 1.25 MHz above or below the band;
2. 50 dB between 1.25 and 2.5 MHz above or below the band; and
3. 60 dB at 2.5 MHz or greater above or below the band, or shall meet the requirement of FCC Rule 15.319(g) which shall not exceed the limits of FCC Rule 15.209 / RSS-210 Clause 2.5.

Example: Calculation of Limit for emissions between the band edge and 1.25 MHz (1920.000 – 1918.750 MHz)

The emissions shall not exceed the Limit: 20.5 dBm – 30 dB = -9.5 dBm

Measurements are made in accordance with ANSI C63.17 sub-clause 6.1.6.2. Radiated emissions test method is used. Emissions that are directly caused by digital circuits in the transmit path and transmitter portion are measured.

Test setup is shown in section 3.2 Figure 3.2.1

Test Results:

Channel	Carrier Frequency (MHz)	Measured Band (MHz)	Limit (dBm)	Results
Lowest	1921.536	1920.000 - 1918.750	-9.5	Pass
		1918.750 - 1917.500	-29.5	Pass
		0.009 - 1917.500 & 1932.500 - 19300.000	-39.5 / FCC Rule 15.209 / RSS-Gen Clause 8.9	Pass
Highest	1928.448	1930.000 - 1931.250	-9.5	Pass
		1931.250 - 1932.500	-29.5	Pass
		0.009 – 1917.500 & 1932.500 - 19300.000	-39.5 / FCC Rule 15.209 / RSS-Gen Clause 8.9	Pass

TEST REPORT

4.4.1 Radiated Emissions Configuration Photographs:

Worst Case Radiated Emission
at
3856.896 MHz

The worst case radiated emission configuration photographs are saved with filename: config photos.pdf

4.4.2 Radiated Emissions Data:

Data are included of the worst case configuration (the configuration which resulted in the highest emission levels). A sample calculation, configuration photographs and data tables of the emissions are included. All measurements were performed with peak detection unless otherwise specified.

The data in table 1-7 list the significant emission frequencies, the limit and the margin of compliance.

Judgement:

Passed by 1.1 dB margin compared with average limit

TEST REPORT

RADIATED EMISSIONS DATA

Mode: Transmission with Ten Pao Adaptor

Table 1, Base Unit

Pursuant to FCC Part 15 Section 15.209 / RSS-Gen Clause 8.9 Emissions Requirements

Lowest Channel

Polari- zation	Frequency (MHz)	Reading (dBµV)	Pre-Amp Gain (dB)	Antenna Factor (dB)	Net at 3m - Peak (dBµV/m)	Average Factor (dB)	Calculated at 3m (dBµV/m)	Average Limit at 3m (dBµV/m)	Margin (dB)
H	3843.072	64.1	33	33.3	64.4	13.6	50.8	54.0	-3.2
V	5764.608	52.3	33	36.6	55.9	13.6	42.3	54.0	-11.7
V	7686.144	52.4	33	38.9	58.3	13.6	44.7	54.0	-9.3
V	9607.680	57.5	33	40.4	64.9	13.6	51.3	54.0	-2.7
H	11529.216	54.7	33	40.5	62.2	13.6	48.6	54.0	-5.4
H	13450.752	54.5	33	41.9	63.4	13.6	49.8	54.0	-4.2

Polari- zation	Frequency (MHz)	Reading (dBµV)	Pre-Amp Gain (dB)	Antenna Factor (dB)	Net at 3m - Peak (dBµV/m)	Peak Limit at 3m (dBµV/m)	Margin (dB)
H	3843.072	64.1	33	33.3	64.4	74.0	-9.6
V	5764.608	52.3	33	36.6	55.9	74.0	-18.1
V	7686.144	52.4	33	38.9	58.3	74.0	-15.7
V	9607.680	57.5	33	40.4	64.9	74.0	-9.1
H	11529.216	54.7	33	40.5	62.2	74.0	-11.8
H	13450.752	54.5	33	41.9	63.4	74.0	-10.6

NOTES:

1. Peak detector is used for the emission measurement.
2. The resolution bandwidth of the spectrum analyzer was set 100 kHz and 1 MHz for spurious emission measurements below 1 GHz and above 1 GHz respectively.
3. All measurements were made at 3 meters.
4. Negative value in the margin column shows emission below limit.

TEST REPORT

Mode: Transmission with Ten Pao Adaptor

Table 2, Base Unit

Pursuant to FCC Part 15 Section 15.209 / RSS-Gen Clause 8.9 Emissions Requirements

Highest Channel

Polarization	Frequency (MHz)	Reading (dBµV)	Pre-Amp Gain (dB)	Antenna Factor (dB)	Net at 3m - Peak (dBµV/m)	Average Factor (dB)	Calculated at 3m (dBµV/m)	Average Limit at 3m (dBµV/m)	Margin (dB)
H	3856.896	66.2	33	33.3	66.5	13.6	52.9	54.0	-1.1
H	5785.344	54.3	33	36.6	57.9	13.6	44.3	54.0	-9.7
H	7713.792	53.9	33	38.9	59.8	13.6	46.2	54.0	-7.8
H	9642.240	56.1	33	40.4	63.5	13.6	49.9	54.0	-4.2
V	11570.688	55.7	33	40.5	63.2	13.6	49.6	54.0	-4.4
V	13499.136	53.3	33	41.9	62.2	13.6	48.6	54.0	-5.4

Polarization	Frequency (MHz)	Reading (dBµV)	Pre-Amp Gain (dB)	Antenna Factor (dB)	Net at 3m - Peak (dBµV/m)	Peak Limit at 3m (dBµV/m)	Margin (dB)
H	3856.896	66.2	33	33.3	66.5	74.0	-7.5
H	5785.344	54.3	33	36.6	57.9	74.0	-16.1
H	7713.792	53.9	33	38.9	59.8	74.0	-14.2
H	9642.240	56.1	33	40.4	63.5	74.0	-10.6
V	11570.688	55.7	33	40.5	63.2	74.0	-10.8
V	13499.136	53.3	33	41.9	62.2	74.0	-11.8

NOTES:

1. Peak detector is used for the emission measurement.
2. The resolution bandwidth of the spectrum analyzer was set 100 kHz and 1 MHz for spurious emission measurements below 1 GHz and above 1 GHz respectively.
3. All measurements were made at 3 meters.
4. Negative value in the margin column shows emission below limit.

TEST REPORT

Mode: Talk with Ten Pao Adaptor

Table 3, Base Unit

Pursuant to FCC Part 15 Section 15.323 (d) / RSS-213 Clause 5.8.1 Emissions Requirements

Polarization	Frequency (MHz)	Measured Power (dBm)	Power Limit (dBm)	Margin (dB)
V	98.301	-61.6	-39.5	-22.1
V	121.525	-70.8	-39.5	-31.3
V	131.884	-69.4	-39.5	-29.9
V	196.606	-64.1	-39.5	-24.6
V	393.306	-64.5	-39.5	-25.0
H	961.731	-54.2	-39.5	-14.7

NOTES:

1. Peak detector is used for the emission measurement.
2. All measurements were made at 3 meters.
3. Negative value in the margin column shows emission below limit.

TEST REPORT

Mode: Talk with VTPL Adaptor

Table 4, Base Unit

Pursuant to FCC Part 15 Section 15.323 (d) / RSS-213 Clause 5.8.1 Emissions Requirements

Polarization	Frequency (MHz)	Measured Power (dBm)	Power Limit (dBm)	Margin (dB)
V	50.244	-69.0	-39.5	-29.5
V	98.247	-67.9	-39.5	-28.4
V	121.159	-68.4	-39.5	-28.9
V	196.606	-58.8	-39.5	-19.3
H	393.184	-62.6	-39.5	-23.1
V	589.891	-63.8	-39.5	-24.3

NOTES:

1. Peak detector is used for the emission measurement.
2. All measurements were made at 3 meters.
3. Negative value in the margin column shows emission below limit.

TEST REPORT

Mode: Talk with Ao Hai Adaptor

Table 5, Base Unit

Pursuant to FCC Part 15 Section 15.323 (d) / RSS-213 Clause 5.8.1 Emissions Requirements

Polarization	Frequency (MHz)	Measured Power (dBm)	Power Limit (dBm)	Margin (dB)
H	30.606	-69.6	-39.5	-30.1
V	98.299	-63.4	-39.5	-23.9
V	131.884	-67.4	-39.5	-27.9
V	196.600	-61.1	-39.5	-21.6
H	393.184	-62.7	-39.5	-23.2
V	961.000	-55.1	-39.5	-15.6

NOTES:

1. Peak detector is used for the emission measurement.
2. All measurements were made at 3 meters.
3. Negative value in the margin column shows emission below limit.

TEST REPORT

4.4.3 Field Strength Calculation

The field strength is calculated by adding the reading on the Spectrum Analyzer to the factors associated with preamplifiers (if any), antennas, cables, pulse desensitization and average factors (when specified limit is in average and measurements are made with peak detectors). A sample calculation is included below.

$$FS = RA + AF + CF - AG + PD + AV$$

Where FS = Field Strength in dB μ V/m

RA = Receiver Amplitude (including preamplifier) in dB μ V

CF = Cable Attenuation Factor in dB

AF = Antenna Factor in dB

AG = Amplifier Gain in dB

PD = Pulse Desensitization in dB

AV = Average Factor in -dB

In the radiated emission table which follows, the reading shown on the data table may reflect the preamplifier gain. An example of the calculations, where the reading does not reflect the preamplifier gain, follows:

$$FS = RA + AF + CF - AG + PD + AV$$

Example

Assume a receiver reading of 62.0 dB μ V is obtained. The antenna factor of 7.4 dB and cable factor of 1.6 dB is added. The amplifier gain of 29.0 dB is subtracted. The pulse desensitization factor of the spectrum analyzer is 0.0 dB, and the resultant average factor is -10.0 dB. The net field strength for comparison to the appropriate emission limit is 32.0 dB μ V/m. This value in dB μ V/m is converted to its corresponding level in μ V/m.

$$RA = 62.0 \text{ dB}\mu\text{V}$$

$$AF = 7.4 \text{ dB}$$

$$CF = 1.6 \text{ dB}$$

$$AG = 29.0 \text{ dB}$$

$$PD = 0.0 \text{ dB}$$

$$AV = -10 \text{ dB}$$

$$FS = 62.0 + 7.4 + 1.6 - 29.0 + 0.0 + (-10.0) = 32.0 \text{ dB}\mu\text{V/m}$$

$$\text{Level in } \mu\text{V/m} = \text{Common Antilogarithm } [(32.0 \text{ dB}\mu\text{V/m})/20] = 39.8 \mu\text{V/m}$$

TEST REPORT

4.4.4 Average Factor Calculation and Transmitter ON Time Measurements, FCC Rule 15.35(b, c) / RSS-Gen cl 4.5

Base Unit: (For 4 handsets operation with dummy)

Duty Cycle (DC) = $(4+1)/24$

Average Factor (AF) = $20 \log ((4+1)/24)$
= -13.6 dB

TEST REPORT

4.5 AC Power Line Conducted Emissions, FCC Rule 15.315 / RSS-213 Clause 5.4:

The AC power line conducted emission shall not exceed the limits of FCC Rule 15.207 / Table 4 in RSS-Gen Clause 7.2.4.

Measurements are made in accordance with ANSI C63.4 sub-clause 7. Emissions that are directly caused by digital circuits in the transmit path and transmitter portion are measured.

Test setup is shown in section 3.3 Figure 3.3.1.

- [] Not applicable – EUT is only powered by battery for operation.

- [] EUT connects to AC power line. Emission Data is listed in following pages.

- [×] Base Unit connects to AC power line and has transmission. Handset connects to AC power line (indirectly) but has no transmission. Emission Data of Base Unit is listed in following pages.

- [] Handset connects to AC power line (indirectly) only during charging. Emission Data is listed in following pages.

TEST REPORT

4.5.1 AC Power Line Conducted Emissions Configuration Photographs:

Worst Case AC Power Line Conducted Emission
at

3.399 MHz

The worst case AC power Line conducted emission configuration photographs are saved with filename: config photos.pdf

4.5.2 AC Power Line Conducted Emissions Data:

The plot(s) and data in the following pages list the significant emission frequencies, the limit and the worst case margin of compliance.

Judgment:

Passed by 5.72 dB margin compared with quasi-peak limit

TEST REPORT

Worst Case: Talk with Ten Pao Adaptor

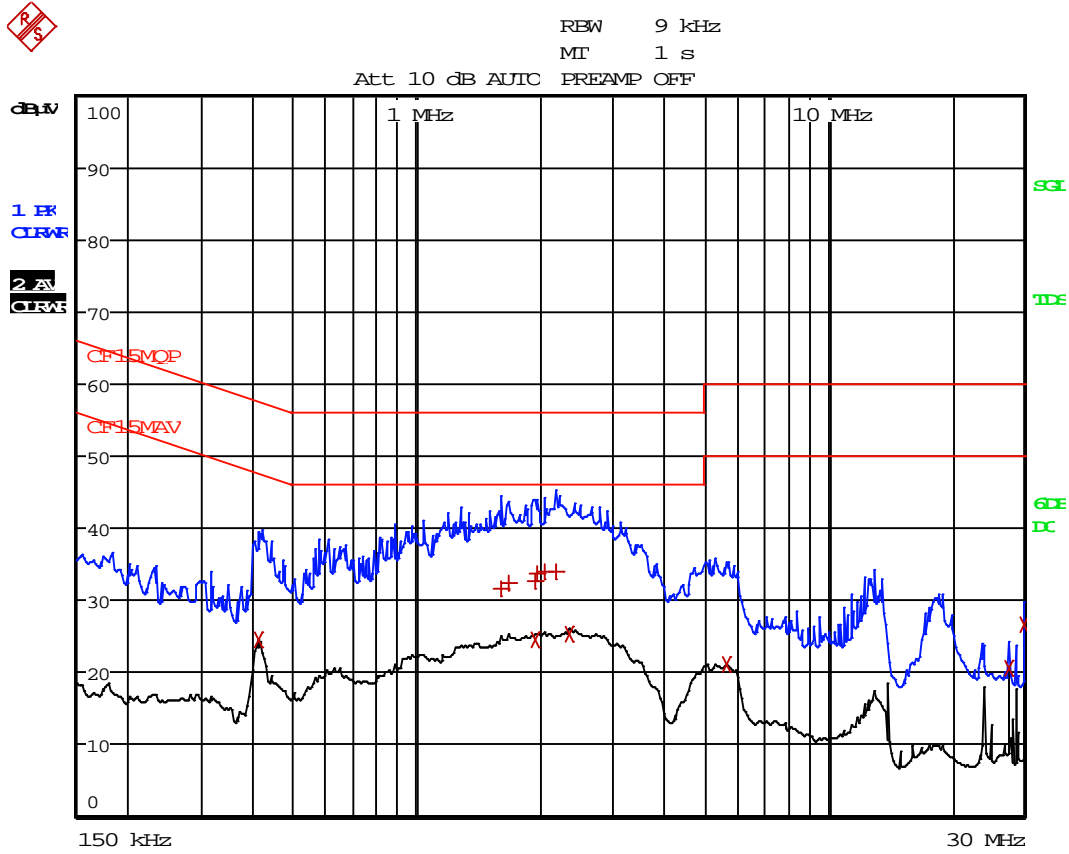

TEST REPORT

Worst Case:

Talk with Ten Pao Adaptor

EDIT PEAK LIST (Final Measurement Results)				
Trace1:		CF15MQP		
Trace2:		CF15MAV		
Trace3:		---		
TRACE	FREQUENCY	LEVEL dB μ V		DELTA LIMIT dB
2 CISPR Average	411 kHz	24.66	L1	-22.96
1 Quasi Peak	1.599 MHz	31.68	L1	-24.32
1 Quasi Peak	1.68 MHz	32.44	L1	-23.56
1 Quasi Peak	1.941 MHz	32.75	L1	-23.24
2 CISPR Average	1.941 MHz	24.60	L1	-21.39
1 Quasi Peak	1.968 MHz	33.64	N	-22.35
1 Quasi Peak	2.058 MHz	33.93	L1	-22.07
1 Quasi Peak	2.1795 MHz	34.06	N	-21.93
2 CISPR Average	2.3415 MHz	25.25	L1	-20.74
2 CISPR Average	5.6895 MHz	21.17	L1	-28.82
2 CISPR Average	27.6495 MHz	20.62	L1	-29.37
2 CISPR Average	29.9985 MHz	26.57	L1	-23.42

TEST REPORT

Worst Case:

Talk with VTPL Adaptor

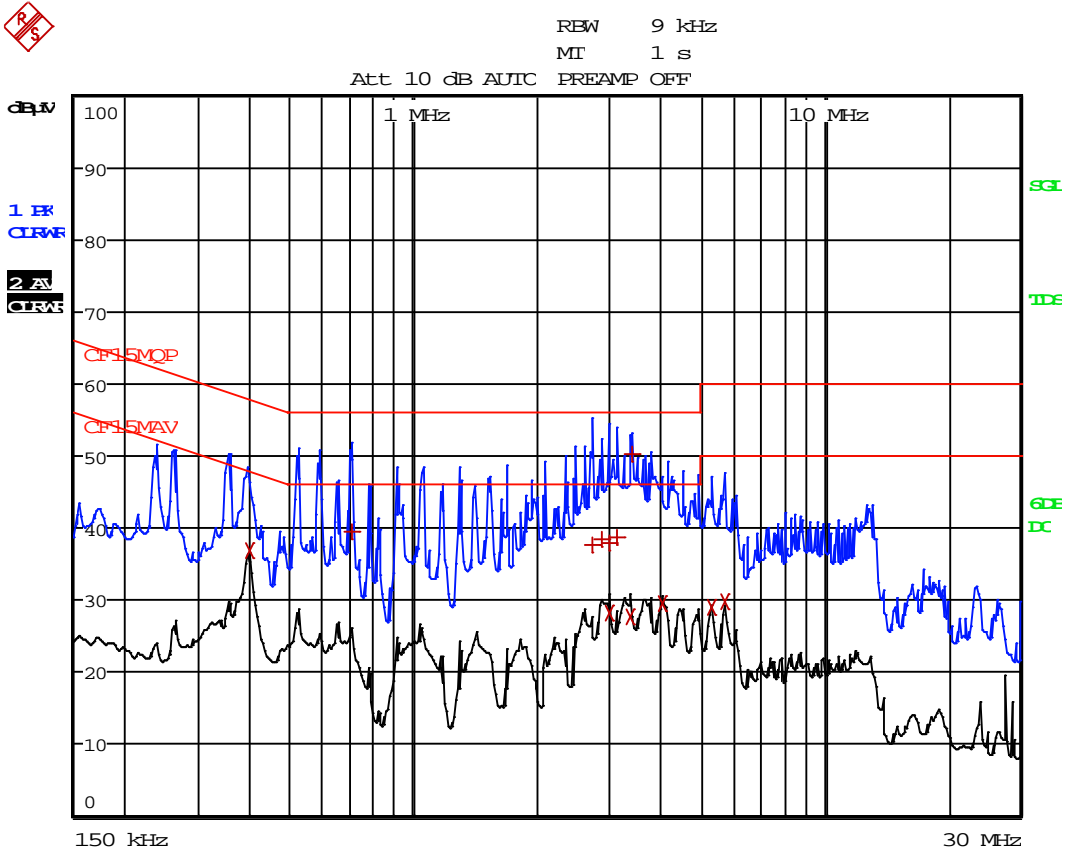

TEST REPORT

Worst Case:

Talk with VTPL Adaptor

EDIT PEAK LIST (Final Measurement Results)				
Trace1:		CF15MQP		
Trace2:		CF15MAV		
Trace3:		---		
TRACE	FREQUENCY	LEVEL dB μ V		DELTA LIMIT dB
2 CISPR Average	397.5 kHz	36.92	L1	-10.98
1 Quasi Peak	708 kHz	39.55	L1	-16.44
1 Quasi Peak	2.7375 MHz	37.66	N	-18.33
1 Quasi Peak	2.868 MHz	38.56	L1	-17.43
2 CISPR Average	2.994 MHz	28.11	L1	-17.89
1 Quasi Peak	2.9985 MHz	37.84	N	-18.15
1 Quasi Peak	3.129 MHz	38.76	N	-17.23
2 CISPR Average	3.3855 MHz	27.78	L1	-18.21
1 Quasi Peak	3.399 MHz	50.27	N	-5.72
2 CISPR Average	4.038 MHz	29.58	L1	-16.41
2 CISPR Average	5.334 MHz	28.91	L1	-21.08
2 CISPR Average	5.7345 MHz	29.67	N	-20.32

TEST REPORT

Worst Case: Talk with Ao Hai Adaptor

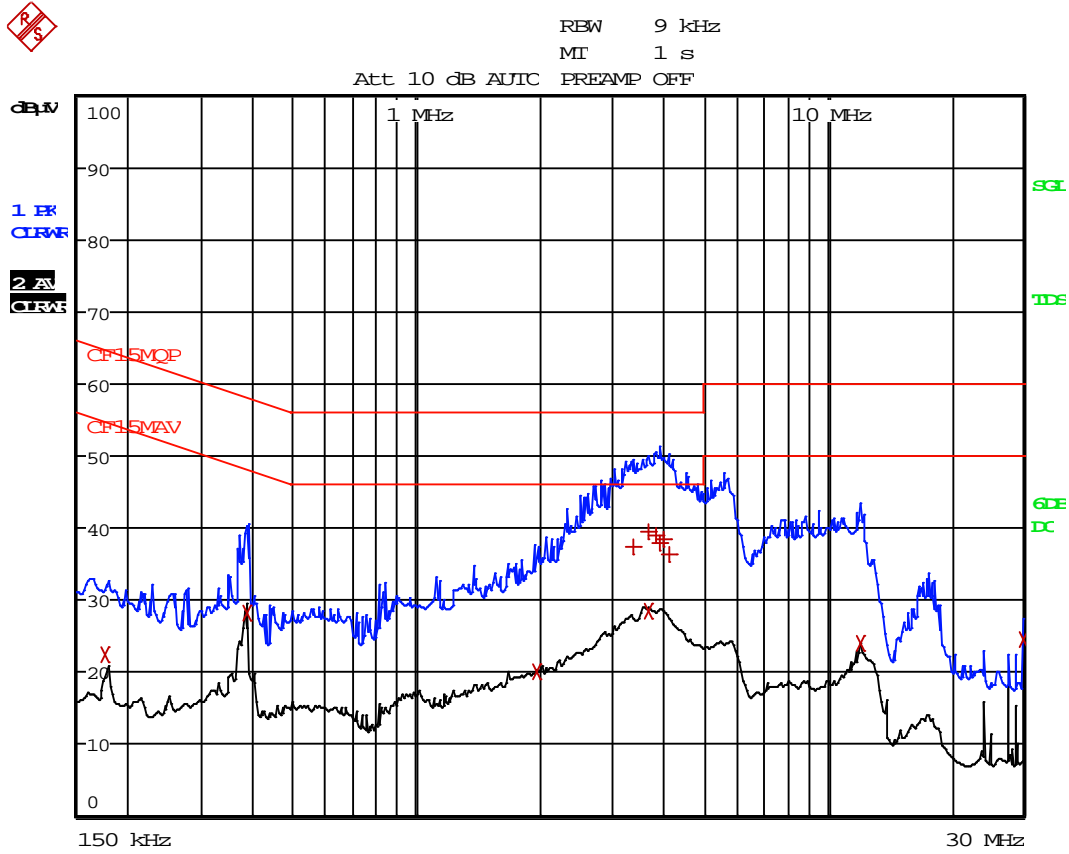

TEST REPORT

Worst Case:

Talk with Ao Hai Adaptor

EDIT PEAK LIST (Final Measurement Results)				
Trace1:		CF15MQP		
Trace2:		CF15MAV		
Trace3:		---		
TRACE	FREQUENCY	LEVEL dB μ V		DELTA LIMIT dB
2 CISPR Average	177 kHz	22.52	L1	-32.09
2 CISPR Average	384 kHz	28.21	N	-19.98
2 CISPR Average	1.9635 MHz	20.15	N	-25.84
1 Quasi Peak	3.39 MHz	37.43	N	-18.56
1 Quasi Peak	3.6645 MHz	39.56	N	-16.43
2 CISPR Average	3.669 MHz	28.34	N	-17.65
1 Quasi Peak	3.8175 MHz	38.90	L1	-17.09
1 Quasi Peak	3.9165 MHz	38.05	N	-17.94
1 Quasi Peak	3.9975 MHz	38.55	L1	-17.44
1 Quasi Peak	4.1145 MHz	36.44	N	-19.55
2 CISPR Average	12.012 MHz	24.14	N	-25.85
2 CISPR Average	29.9985 MHz	24.58	L1	-25.41

TEST REPORT

5.0 EQUIPMENT LIST

1) Radiated Emissions Test

Equipment	EMI Test Receiver	Spectrum Analyzer	Biconical Antenna
Registration No.	EW-3156	EW-2253	EW-0571
Manufacturer	R&S	R&S	EMCO
Model No.	ESR26	FSP40	3104C
Calibration Date	August 01, 2019	November 18, 2019	July 23, 2019
Calibration Due Date	November 01, 2020	November 18, 2020	January 23, 2021

Equipment	Log Periodic Antenna	High Frequency Coaxial Cable Assembly (4 pcs)	Double Ridged Guide Antenna
Registration No.	EW-0447	EW-2107	EW-0194
Manufacturer	EMCO	RADIALL	EMCO
Model No.	3146	SMA(m)-SHF5MPU-SMA(m) R.A 14m	3115
Calibration Date	September 25, 2019	July 03, 2020	September 26, 2019
Calibration Due Date	March 25, 2021	July 03, 2021	March 26, 2021

Equipment	Notch Filter (cutoff frequency 1.9GHz to 2.0GHz)	Pyramidal Horn Antenna (18.0 - 26.5)GHz
Registration No.	EW-3434	EW-0905
Manufacturer	MICROWAVE	EMCO
Model No.	N0319501	3160-09
Calibration Date	November 16, 2019	July 23, 2019
Calibration Due Date	November 16, 2020	January 23, 2021

2) Conducted Emissions Test

Equipment	EMI Test Receiver	RF Cable 120cm (RG142) (9kHz to 30MHz)	LISN
Registration No.	EW-3156	EW-2453	EW-2501
Manufacturer	ROHDESCHWARZ	RADIALL	R&S
Model No.	ESR26	bnc m st / 142 / bnc m st 100c	ENV-216
Calibration Date	September 30, 2020	January 07, 2020	September 11, 2020
Calibration Due Date	September 30, 2021	January 07, 2021	September 11, 2021

END OF TEST REPORT