

Serial No. Label(size: 28x10mm)
Model #:CL82101(1Ci BS + 1HS)

- CL82201(1Ci BS + 2HS + 1 CHG)
- CL82301(1Ci BS + 3HS + 2 CHG)
- CL82401(1Ci BS + 4HS + 3 CHG)
- CL82501(1Ci BS + 5HS + 4 CHG)
- CL82601(1Ci BS + 6HS + 5 CHG)

Text: Raised 0.3mm

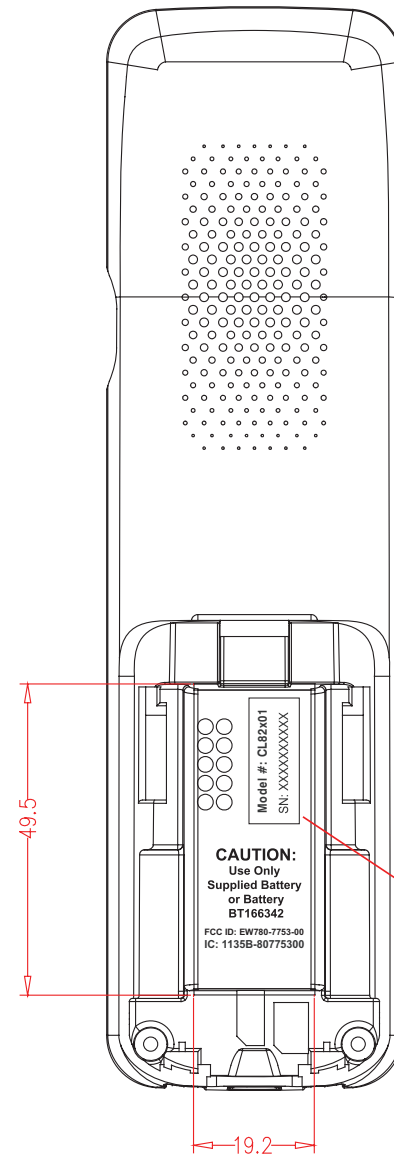

HS for
CL80101
CL81101
CL81201
CL81301

CL82101
CL82201
CL82301
CL82401
CL82501
CL82601

HS BATT
CAUTION LABEL

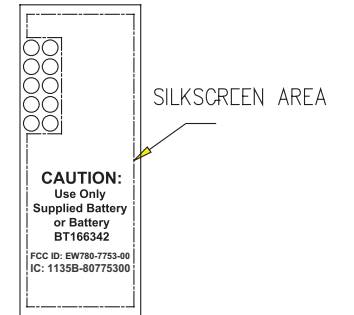

Serial No. Label 20*8 MM