

# Base (TL32100, TL32200, TL32300)

Text: engraved in recessed  
0.3mm depth, text surface in

high gloss

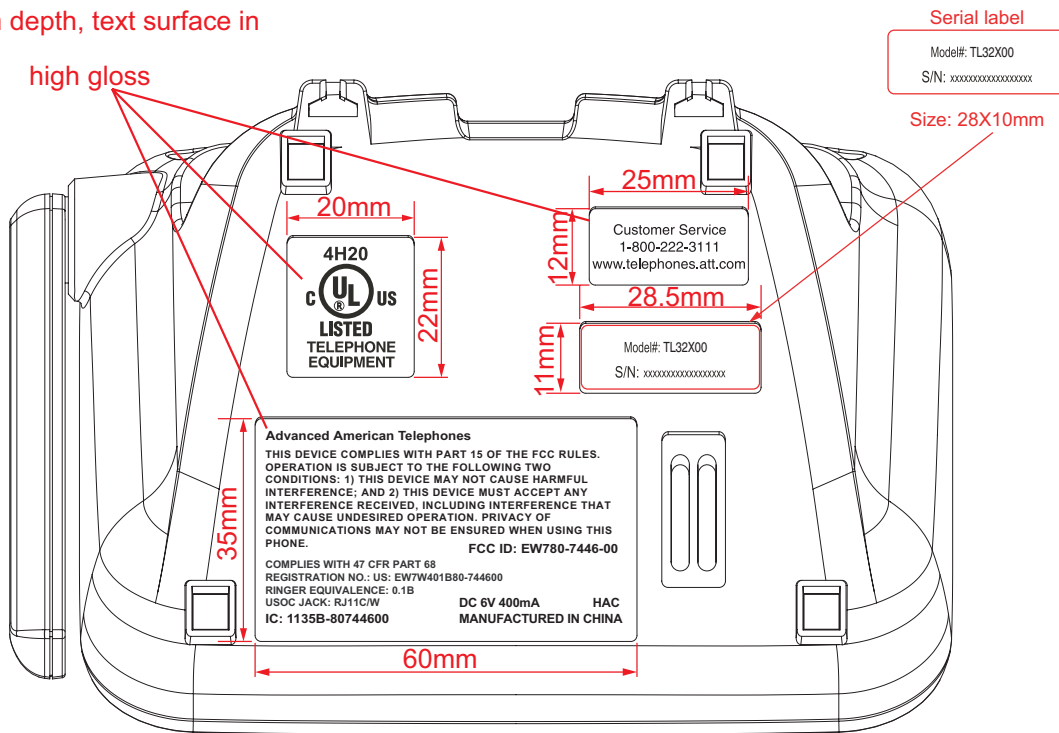

Text: engraved in raised 0.3mm

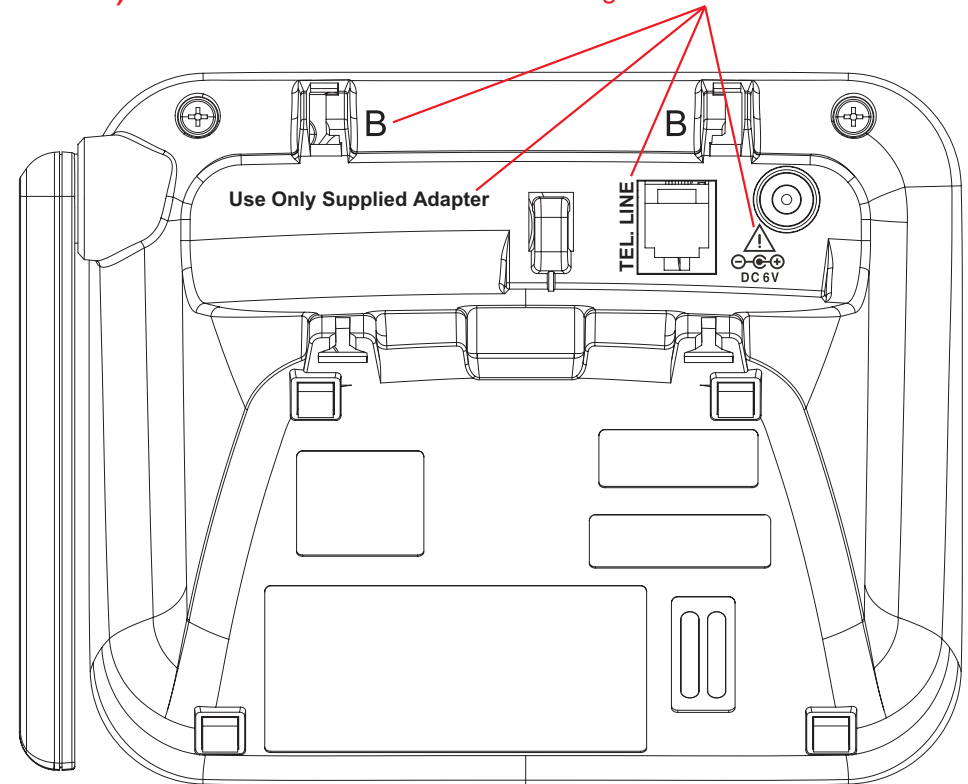

# Handset

(TL30100,  
TL32100,  
TL32200,  
TL32300)

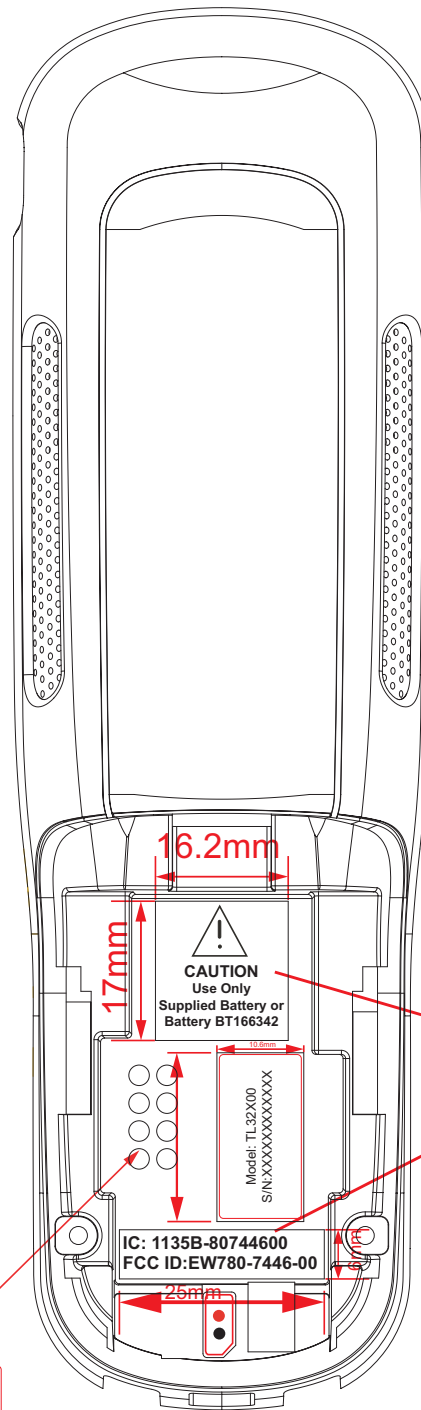

Text: engraved in recessed  
0.3mm depth, text surface in  
high gloss

Serial label

Model: TL32X00  
S/N:XXXXXXXXXXXXXX

Size: 20X10mm