



VTech Telecommunications Ltd.

Application
For
Permissive Change Class II

Unlicensed Personal Communication Service Devices

FCC ID: EW780-6948-00

Test Report Number: HK08110392-1

Issue Date: December 12, 2008

TL/ ac

- The test report only allows to be revised within the retention period unless further standard or the requirement was noticed.
- This report is for the exclusive use of Intertek's Client and is provided pursuant to the agreement between Intertek and its Client. Intertek's responsibility and liability are limited to the terms and conditions of the agreement. Intertek assumes no liability to any party, other than to the Client in accordance with the agreement, for any loss, expense or damage occasioned by the use of this report. Only the Client is authorized to permit copying or distribution of this report and then only in its entirety. Any use of the Intertek name or one of its marks for the sale or advertisement of the tested material, product or service must first be approved in writing by Intertek. The observations and test results in this report are relevant only to the sample tested. This report by itself does not imply that the material, product, or service is or has ever been under an Intertek certification program.

Intertek Testing Services Hong Kong Ltd.

2/F., Garment Centre, 576 Castle Peak Road, Kowloon, Hong Kong.
Tel: (852) 2173 8888 Fax: (852) 2785 5487 Website: www.hk.intertek-etlsemko.com

LIST OF EXHIBITS

INTRODUCTION

<i>EXHIBIT 1:</i>	Summary of Tests
<i>EXHIBIT 2:</i>	General Description
<i>EXHIBIT 3:</i>	System Test Configuration
<i>EXHIBIT 4:</i>	Measurement Results
<i>EXHIBIT 5:</i>	Equipment Photographs
<i>EXHIBIT 6:</i>	Product Labelling
<i>EXHIBIT 7:</i>	Technical Specifications
<i>EXHIBIT 8:</i>	Instruction Manual
<i>EXHIBIT 9:</i>	Letter of Agency
<i>EXHIBIT 10:</i>	Confidentiality Request

INTERTEK TESTING SERVICES

MEASUREMENT/TECHNICAL REPORT

VTech Telecommunications Ltd.

Model: CL81xy9, CL82xy9, CL84xy9, CL80109

FCC ID: EW780-6948-00

This report concerns (check one:) Original Grant Class II Change

Equipment Type : PUB - Part 15 Unlicensed PCS Base Station
PUE - Part 15 Unlicensed PCS portable Tx held to ear

Deferred grant requested per 47 CFR 0.457(d)(1)(ii)? Yes No

If yes, defer until :

Date

Company Name agrees to notify the Commission by: _____
Date

of the intended date of announcement of the product so that the grant can be issued on that date.

Transition Rules Request per 15.37? Yes No

If no, assumed Part 15, Subpart D for Unlicensed Personal Communication Service Device - the new 47 CFR [10-01-07 Edition] Provision.

Report prepared by: Leung Wai Leung, Tommy

Intertek Testing Services Hong Kong Ltd.
2/F., Garment Centre,
576 Castle Peak Road,
Kowloon, Hong Kong.
Phone : 852-2173-8538
Fax: 852-2741-1693

INTERTEK TESTING SERVICES

Table of Contents

1.0 Summary of Test Results	6
2.0 General Description	8
2.1 Product Description	8
2.2 Purpose of Application.....	9
2.3 Test Methodology.....	9
2.4 Test Facility	9
3.0 System Test Configuration	11
3.1 Justification	11
3.2 Conducted Emission Test Configuration	12
3.3 Conducted Monitoring and Operational Test Configuration	12
3.4 EUT Exercising Software.....	12
3.5 Details of EUT and Description of Peripherals	13
3.6 Measurement Uncertainty	14
3.7 Equipment Modification	14
4.0 Measurement Results	16
4.1 Antenna Requirement	16
4.2 Directional Gain of the Antenna	17
4.3 Power Spectral Density	18
4.4 Unwanted Emission Inside the Sub-Band	20
4.5 Emissions Outside the Sub-Band	22
4.5.1 Radiated Emissions Configuration Photographs	23
4.5.2 Radiated Emissions Data	24
4.5.3 Field Strength Calculation.....	40
4.5.4 Transmitter Duty Cycle Calculation and Measurements	41
4.6 AC Power Lines Conducted Emissions from Transmitter portion of EUT	42
4.6.1 AC Power Lines Conducted Emissions Configuration Photographs.....	43
4.6.2 AC Power Line Conducted Emissions Data	44
4.7 Radio Frequency Radiation Exposure	45
4.8 Monitoring Antenna	46
5.0 Equipment Photographs	48
6.0 Product Labelling	50
7.0 Technical Specifications	52
8.0 Instruction Manual	54
9.0 Letter of Agency	56
10.0 Confidentiality Request	58

INTERTEK TESTING SERVICES

List of Attached Files

Exhibit Type	File Description	Filename
Operational Description	Technical Description	descri.pdf
Cover Letter	Purpose of Change	product change.pdf
Test Report	Test Report	report.pdf
Test Report	Power Spectral Density Plots	psd.pdf
Test Report	Unwanted Emission Inside Sub-Band Plots	inband.pdf
Test Report	Duty Cycle Calculation and Measurement	dcc.pdf
Test Report	AC Lines Conducted Emission Data	conduct.pdf
Test Setup Photos	Radiated Emission Test Configuration	config photos. pdf
Test Setup Photos	AC Lines Conducted Emission Test Configuration	
RF Exposure Info	RF Safety	RF exposure info.pdf
	SAR Report	SAR Report.pdf
External Photos	External Photo	external photos.pdf
Internal Photos	Internal Photo	internal photos.pdf
ID Label/Location Info	Label Artwork and Location	label.pdf
Cover Letter	Label Location Justification	justification.pdf
Block Diagrams	Block Diagram	block.pdf
Schematics	Circuit Diagram	circuit.pdf
Users Manual	User Manual	manual 1 of 4.pdf manual 2 of 4.pdf manual 3 of 4.pdf manual 4 of 4.pdf
Cover Letter	Letter of Agency	letter of agency.pdf
Cover Letter	Confidentiality Request	request.pdf

**EXHIBIT 1
SUMMARY OF TEST RESULTS**

INTERTEK TESTING SERVICES

1.0 Summary of Test Results

VTech Telecommunications Ltd.

Model: CL81xy9, CL82xy9, CL84xy9, CL80109

FCC ID: EW780-6948-00

Technical Requirements				
Test Items	FCC Part 15 Section	Test Procedure ANSI C63.17 / ANSI C63.4 *	Results	Details see section
Antenna Requirement	15.317	---	Pass	4.1
Directional Gain of the Antenna	15.319(e)	4.3.1	Pass	4.2
Power Spectral Density	15.319(d)	6.1.5	Pass	4.3
Unwanted Emission Inside the Sub-Band	15.323(d)	6.1.6.1	Pass	4.4
Emissions Outside the Sub-Band	15.323(d)	6.1.6.2	Pass	4.5
AC Power Lines Conducted Emissions from Transmitter Portion of EUT	15.315	7 *	Pass	4.6
Radio Frequency Radiation Exposure	15.319(i)	---	Pass	4.7
Monitoring Antenna	15.323(c)(8)	4	Pass	4.8

Test Engineer:

Approved By:



Ken Sit
Assistant Manager



Leung Wai Leung, Tommy
Senior Manager

Date: December 12, 2008

Date: December 12, 2008

**EXHIBIT 2
GENERAL DESCRIPTION**

INTERTEK TESTING SERVICES

2.0 General Description

2.1 Product Description

The CL81109 is a 1.9GHz Digital Modulation Cordless Phone with Caller ID and Speakerphone. It operates at frequency range of 1921.536MHz to 1928.448MHz with 5 channels (1921.536MHz, 1923.264MHz, 1924.992MHz, 1926.720MHz and 1928.448MHz). The Base Unit is powered by an adaptor 117VAC to 6VAC 300mA. The Handset is powered by a "Ni-MH" type rechargeable battery pack (2.4V 450mAh, 500mAh, 550mAh, 750mAh).

The CL82109 is a 1.9GHz Digital Modulation Cordless Phone with Caller ID, Speakerphone and Digital Answering Machine. It operates at frequency range of 1921.536MHz to 1928.448MHz with 5 channels (1921.536MHz, 1923.264MHz, 1924.992MHz, 1926.720MHz and 1928.448MHz). The Base Unit is powered by an adaptor 100-120VAC to 6VDC 400mA. The Handset is powered by a "Ni-MH" type rechargeable battery pack (2.4V 450mAh, 500mAh, 550mAh, 750mAh).

The antennas used in base unit and handset are integral, and the test sample is a prototype.

The Model: CL81xy9 is the same as the Model: CL81109 in hardware aspect. Suffix (xy) indicates different number of handset and packaging. The difference in model number serves as marketing strategy.

The Model: CL82xy9 is the same as the Model: CL82109 in hardware aspect. Suffix (xy) indicates different number of handset and packaging. The difference in model number serves as marketing strategy.

Model: CL80109 is one handset with an external charger for selling.

The Handsets of Models CL81xy9, CL82xy9, CL84xy9, CL80109 are identical as follows: electrical designs, including software and firmware, PCB layout and construction design/ physical design/ enclosure.

Connection between the base unit and the telephone network is accomplished through the use of USOC RJ11C in the 2-wire loop calling central office line.

The technical description is saved as filename: descri.pdf

INTERTEK TESTING SERVICES

2.2 Purpose of Application

The purpose of change is saved as filename: product change.pdf

For the Model: CL81109 and CL82109, the RF module and algorithm are the same as the previous granted Model: CS6219 and CS6229. Enclosure, Baseband PCB layout, and Base antenna are changed.

This is an application for Certification of a PUB - Part 15 Unlicensed PCS Base Station, PUE - Part 15 Unlicensed PCS portable Tx held to ear. The device is also subject to Part 68 Registration. A Verification report has been prepared for the digital device portion.

2.3 Test Methodology

The radiated emission measurements for unintentional radiator (if any) and AC power line-conducted emission measurements were performed according to the test procedures specified in ANSI C63.4 (2003). The radiated emission measurements for intentional radiator contained in UPCS device, antenna conducted measurements were performed according to the test procedures specified in ANSI C63.17 (2006). All radiated measurements were performed in Open Area Test Sites. Preliminary scans were performed in the Open Area Test Sites only to determine worst case modes. All radiated tests were performed at an antenna to EUT distance of 3 meters, unless stated otherwise in the "Justification Section" of this Application. All other measurements were made in accordance with the procedures in 47 CFR Part 2.

2.4 Test Facility

The open area test site and conducted measurement facility used to collect the emission data is located at Garment Centre, 576 Castle Peak Road, Kowloon, Hong Kong. This test facility and site measurement data have been fully placed on file with the FCC.

**EXHIBIT 3
SYSTEM TEST CONFIGURATION**

INTERTEK TESTING SERVICES

3.0 System Test Configuration

3.1 Justification

For emissions testing, the equipment under test (EUT) was setup to transmit continuously in burst mode with pseudo-random data to simplify the measurement methodology. Care was taken to ensure proper power supply voltages during testing. During testing, all cables (if any) were manipulated to produce worst-case emissions. The handset (if any) was powered by a fully charged battery.

For the measurements, the EUT was attached to a plastic stand if necessary and placed on the wooden turntable. If the base unit attached to peripherals, they were connected and operational (as typical as possible).

The signal was maximized through rotation and placement in the three orthogonal axes. The antenna height and polarization were varied during the search for maximum signal level. The antenna height was varied from 1 to 4 meters. Detector function was in peak mode. Radiated emissions were taken at three meters unless the signal level was too low for measurement at that distance. If necessary, a pre-amplifier was used and/or the test was conducted at a closer distance.

The spectrum analyzer resolution bandwidth was approximately 1% of the EUT emission bandwidth, unless otherwise specified.

Radiated emission measurements were performed from the lowest radio frequency signal generated in the device which is greater than 9 kHz to the tenth harmonic of the highest fundamental frequency or to 40 GHz, whichever is lower.

As the base unit has 2 antennas, both have been checked. While conducting the test on one of antennas, another one was being disable its transmission. The data in this report represented the worst-case.

INTERTEK TESTING SERVICES

3.2 Conducted Emission Test Configuration

The setup and equipment setting were made in accordance with ANSI C63.17. The antenna of EUT transmitter was replaced by a coaxial cable. The impedance matching of connection, cable loss and external RF attenuator were taken into account. The EUT was arranged to communicate via a fixed carrier frequency between its transmitter and a companion device. The transmission was configured in burst mode with pseudo-random data as typical as normal operation.

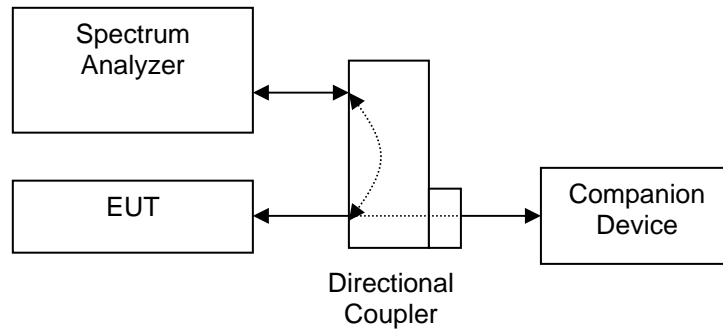

Figure 3.2.1

3.3 Conducted Monitoring and Operational Test Configuration

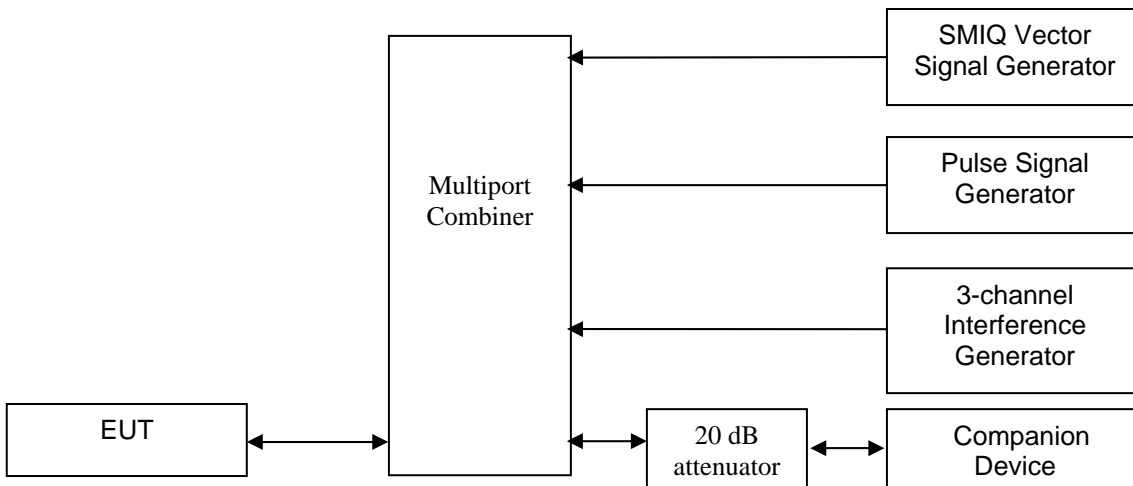

Figure 3.3.1

3.4 EUT Exercising Software

The EUT exercise program (if any) used during radiated and conducted testing was designed to exercise the various system components in a manner similar to a typical use.

INTERTEK TESTING SERVICES

3.5 Details of EUT and Description of Peripherals

Details of EUT:

An AC adaptor and/or a battery (provided with the unit) were used to power the device. Their description are listed below.

- (1) For Model: CL81109 - Base Unit: An AC adaptor (117VAC to 6VAC 300mA, Model: UA-0603) (Supplied by Client)
- (2) For Model: CL82109 - Base Unit: An AC adaptor (100-120VAC to 6VDC 400mA, Model: SSA-5AP-09060040L) (Supplied by Client)
- (3) Handset: A "Ni-MH" Type Rechargeable Battery Pack (2.4V 450mAh, 500mAh, 550mAh, 750mAh) (Supplied by Client)

Description of Peripherals:

- (1) Telecommunication cable with RJ11C connectors (1m, unshielded), terminated (Supplied by Intertek)

INTERTEK TESTING SERVICES

3.6 Measurement Uncertainty

When determining of the test conclusion, the Measurement Uncertainty test has been considered.

Uncertainty and Compliance - Unless the standard specifically states that measured values are to be extended by the measurement uncertainty in determining compliance, all compliance determinations are based on the actual measured value.

3.7 Equipment Modification

Any modifications installed previous to testing by VTech Telecommunications Ltd. will be incorporated in each production model sold/leased in the United States.

No modifications were installed by Commercial and Electrical Division, Intertek Testing Services Hong Kong Ltd.

All the items listed under section 3.0 of this report are confirmed by:

Confirmed by:

*Leung Wai Leung, Tommy
Senior Manager
Intertek Testing Services Hong Kong Ltd.
Agent for VTech Telecommunications Ltd.*



Signature

December 12, 2008 Date

**EXHIBIT 4
MEASUREMENT RESULTS**

INTERTEK TESTING SERVICES

Company: VTech Telecommunications Ltd.
Model: CL81109, CL82109

Date of Test: November 13-24, 2008

4.0 **Measurement Results**

4.1 Antenna Requirement, FCC Rule 15.317:

EUT must meet the antenna requirement of FCC Rule 15.203.

- EUT uses a permanently attached antenna which is considered sufficient to comply with the provisions of this rule. Please refer to Exhibit 5: Internal Photos for more details.

- EUT uses a unique antenna jack or electrical connector which is considered sufficient to comply with the provisions of this rule. Please refer to Exhibit 5: Internal Photos for more details.

INTERTEK TESTING SERVICES

Company: VTech Telecommunications Ltd.
Model: CL81109, CL82109

Date of Test: November 13-24, 2008

4.2 Directional Gain of the Antenna, FCC Rule FCC 15.319(e):

The peak transmit power shall be reduced by the amount in dB that the maximum directional gain of the antenna exceeds 3 dBi.

The requirements are made in accordance with ANSI C63.17 sub-clause 4.3.1.

- Manufacturer declares that the directional gain of the antenna is less than or equal to 3dBi. No peak transmit power reduction is required.
- Manufacturer declares that the directional gain of the antenna is greater than 3dBi. The peak transmit power shall be reduced by _____ dB.

INTERTEK TESTING SERVICES

Company: VTech Telecommunications Ltd.
Model: CL81109, CL82109

Date of Test: November 13-24, 2008

4.3 Power Spectral Density, FCC Rule 15.319(d):

Power spectral density shall not exceed 3 mW (4.8dBm) in any 3 kHz bandwidth as measured with a spectrum analyzer having a resolution bandwidth of 3 kHz.

Measurements are made in accordance with ANSI C63.17 sub-clause 6.1.5. Test setup is shown in section 3.2 Figure 3.2.1.

Test Results:

I. Traffic Carrier - Base Unit - Model: CL81109

Channel	Channel Frequency (MHz)	Measured Power Spectral Density (dBm/3kHz)	Limit (dBm/3 kHz)	Results
Lowest	1921.536	-9.5	4.8	Pass
Highest	1928.448	-10.8	4.8	Pass

II. Dummy Carrier - Base Unit - Model: CL81109

Channel	Channel Frequency (MHz)	Measured Power Spectral Density (dBm/3kHz)	Limit (dBm/3 kHz)	Results
Lowest	1921.536	-11.9	4.8	Pass
Highest	1928.448	-14.1	4.8	Pass

III. Traffic Carrier - Base Unit - Model: CL82109

Channel	Channel Frequency (MHz)	Measured Power Spectral Density (dBm/3kHz)	Limit (dBm/3 kHz)	Results
Lowest	1921.536	-10.6	4.8	Pass
Highest	1928.448	-11.3	4.8	Pass

IV. Dummy Carrier - Base Unit - Model: CL82109

Channel	Channel Frequency (MHz)	Measured Power Spectral Density (dBm/3kHz)	Limit (dBm/3 kHz)	Results
Lowest	1921.536	-13.3	4.8	Pass
Highest	1928.448	-13.7	4.8	Pass

INTERTEK TESTING SERVICES

Company: VTech Telecommunications Ltd.
Model: CL81109, CL82109

Date of Test: November 13-24, 2008

4.3 Power Spectral Density, FCC Rule 15.319(d): - Continued

V. Traffic Carrier - Handset

Channel	Channel Frequency (MHz)	Measured Power Spectral Density (dBm/3kHz)	Limit (dBm/3 kHz)	Results
Lowest	1921.536	-4.1	4.8	Pass
Highest	1928.448	-4.3	4.8	Pass

Please refer to the attached plots for more details:

Base Unit - Model: CL81109

Plot B3A1: Lowest Channel Power Spectral Density (Traffic Carrier)

Plot B3B1: Highest Channel Power Spectral Density (Traffic Carrier)

Plot B3C1: Lowest Channel Power Spectral Density (Dummy Carrier)

Plot B3D1: Highest Channel Power Spectral Density (Dummy Carrier)

Base Unit - Model: CL82109

Plot B3A2: Lowest Channel Power Spectral Density (Traffic Carrier)

Plot B3B2: Highest Channel Power Spectral Density (Traffic Carrier)

Plot B3C2: Lowest Channel Power Spectral Density (Dummy Carrier)

Plot B3D2: Highest Channel Power Spectral Density (Dummy Carrier)

Handset

Plot H3A: Lowest Channel Power Spectral Density (Traffic Carrier)

Plot H3B: Highest Channel Power Spectral Density (Traffic Carrier)

The plots of the power spectral density are saved as filename: psd.pdf

INTERTEK TESTING SERVICES

Company: VTech Telecommunications Ltd.
Model: CL81109, CL82109

Date of Test: November 13-24, 2008

4.4 Unwanted Emission Inside the Sub-Band, FCC Rule 15.323(d):

Emissions inside the sub-band must comply with the following emission mask:

1. In the bands between $1B$ and $2B$ measured from the center of the emission bandwidth, emission shall be at least 30 dB below the permitted peak transmit power
2. In the bands between $2B$ and $3B$ measured from the center of the emission bandwidth, emission shall be at least 50 dB below the permitted peak transmit power
3. In the bands between $3B$ and the band edge, emission shall be at least 60 dB below the permitted peak transmit power

Where B = emission bandwidth in Hz

Measurements are made in accordance with ANSI C63.17 sub-clause 6.1.6.1. Test setup is shown in section 3.2 Figure 3.2.1.

Test Results:

I. Traffic Carrier - Base Unit

Channel	Channel Frequency (MHz)	Results
Lowest	1921.536	Pass
Highest	1928.448	Pass

II. Dummy Carrier - Base Unit

Channel	Channel Frequency (MHz)	Results
Lowest	1921.536	Pass
Highest	1928.448	Pass

III. Traffic Carrier - Handset

Channel	Channel Frequency (MHz)	Results
Lowest	1921.536	Pass
Highest	1928.448	Pass

INTERTEK TESTING SERVICES

Company: VTech Telecommunications Ltd.
Model: CL81109, CL82109

Date of Test: November 13-24, 2008

4.4 Unwanted Emission Inside the Sub-Band, FCC Rule 15.323(d): - Continued

Please refer to the attached plots for more details:

Base Unit - Model: CL81109

Plot B4A1: Lowest Channel Unwanted Emission Inside the Sub-Band (Traffic Carrier)

Plot B4B1: Highest Channel Unwanted Emission Inside the Sub-Band (Traffic Carrier)

Plot B4C1: Lowest Channel Unwanted Emission Inside the Sub-Band (Dummy Carrier)

Plot B4D1: Highest Channel Unwanted Emission Inside the Sub-Band (Dummy Carrier)

Base Unit - Model: CL82109

Plot B4A2: Lowest Channel Unwanted Emission Inside the Sub-Band (Traffic Carrier)

Plot B4B2: Highest Channel Unwanted Emission Inside the Sub-Band (Traffic Carrier)

Plot B4C2: Lowest Channel Unwanted Emission Inside the Sub-Band (Dummy Carrier)

Plot B4D2: Highest Channel Unwanted Emission Inside the Sub-Band (Dummy Carrier)

Handset:

Plot H4A: Lowest Channel Unwanted Emission Inside the Sub-Band (Traffic Carrier)

Plot H4B: Highest Channel Unwanted Emission Inside the Sub-Band (Traffic Carrier)

The plots of the unwanted emission inside the sub-band are saved as filename:
inband.pdf

INTERTEK TESTING SERVICES

Company: VTech Telecommunications Ltd.
Model: CL81109, CL82109

Date of Test: November 13-24, 2008

4.5 Emissions Outside the Sub-Band, FCC Rule 15.323(d):

Emissions outside the sub-band shall be attenuated below a reference power of 112 mW (20.5 dBm) as follows:

1. 30 dB between the band edge and 1.25 MHz above or below the band;
2. 50 dB between 1.25 and 2.5 MHz above or below the band; and
3. 60 dB at 2.5 MHz or greater above or below the band, or shall not exceed the limits of FCC Rule 15.209.

Example: Calculation of Limit for emissions between the band edge and 1.25 MHz (1920.000 – 1918.750 MHz)

The emissions shall not exceed the Limit: 20.5 dBm – 30 dB = -9.5 dBm

Measurements are made in accordance with ANSI C63.17 sub-clause 6.1.6.2. As EUT has non-detachable antenna(s), radiated emissions test method is used for out-of-band emissions tests. Emissions that are directly caused by digital circuits in the transmit path and transmitter portion are measured. Test setup and procedures are described in section 3.2 Figure 3.2.1.

Test Results:

Base Unit & Handset:

Channel	Carrier Frequency (MHz)	Measured Band (MHz)	Limit (dBm)	Results
Lowest	1921.536	1920.000 - 1918.750	-9.5	Pass
		1918.750 - 1917.500	-29.5	Pass
		0.009 - 1917.500 & 1932.500 - 19300.000	-39.5 / FCC Rule 15.209	Pass
Highest	1928.448	1930.000 - 1931.250	-9.5	Pass
		1931.250 - 1932.500	-29.5	Pass
		0.009 - 1917.500 & 1932.500 - 19300.000	-39.5 / FCC Rule 15.209	Pass

Please refer to the section 4.5.1 to 4.5.4 for more details.

INTERTEK TESTING SERVICES

Company: VTech Telecommunications Ltd.
Model: CL81109, CL82109
Mode: Transmission

Date of Test: November 13-24, 2008

4.5.1 Radiated Emissions Configuration Photographs:

Worst Case Radiated Emission
at

Base Unit for CL81109: 7713.792 MHz & 7686.144 MHz

Base Unit for CL82109: 7686.144 MHz

Handset: 3856.892 MHz & 3843.064 MHz

The worst case radiated emission configuration photographs are saved as filename:
config photos.pdf

INTERTEK TESTING SERVICES

Company: VTech Telecommunications Ltd.
Model: CL81109, CL82109
Mode: Transmission

Date of Test: November 13-24, 2008

4.5.2 Radiated Emissions Data:

Data are included of the worst case configuration (the configuration which resulted in the highest emission levels). A sample calculation, configuration photographs and data tables of the emissions are included. All measurements were performed with peak detection unless otherwise specified.

The data in tables 1-15 list the significant emission frequencies, the limit and the margin of compliance.

Judgement -

Base Unit for CL81109: Passed by 1.7 dB margin compare with the average limit

Base Unit for CL82109: Passed by 1.7 dB margin compare with the average limit

Handset: Passed by 5.1 dB margin compare with the peak limit

TEST ENGINEER:



Signature

Ken Sit, Assistant Manager
Typed/Printed Name

December 12, 2008
Date

INTERTEK TESTING SERVICES

Company: VTech Telecommunications Ltd.
Model: CL81109
Mode: Transmission

Date of Test: November 13-24, 2008

Table 1, Base Unit

Radiated Emissions Data
Pursuant To FCC Part 15 Section 15.323 (d) Emissions Requirements

Lowest Channel:

Polarization	Frequency (MHz)	Measured Power (dBm)	Power Limit (dBm)	Margin (dB)
V	1919.721	-44.8	-9.5	-35.3
V	1918.608	-50.0	-29.5	-20.5
V	1917.089	-51.8	-39.5	-12.3

NOTES:

1. Peak detector is used for the emission measurement.
2. All measurements were made at 3 meters.
3. Negative value in the margin column shows emission below limit.

INTERTEK TESTING SERVICES

Company: VTech Telecommunications Ltd.
Model: CL81109
Mode: Transmission

Date of Test: November 13-24, 2008

Table 2, Base Unit

Radiated Emissions Data Pursuant To FCC Part 15 Section 15.209 Emissions Requirements

Lowest Channel:

Polarization	Frequency (MHz)	Reading (dB μ V/m)	Pre-Amp Gain (dB)	Antenna Factor (dB)	Net at 3m - Peak (dB μ V/m)	Average Factor (dB)	Calculated at 3m (dB μ V/m)	Average Limit at 3m (dB μ V/m)	Margin (dB)
H	3843.072	62.2	33	33.3	62.5	15.6	46.9	54.0	-7.1
H	5764.608	59.8	33	36.6	63.4	15.6	47.8	54.0	-6.2
H	7686.144	62.0	33	38.9	67.9	15.6	52.3	54.0	-1.7
V	9607.680	55.6	33	40.4	63.0	15.6	47.4	54.0	-6.6
V	11529.216	54.6	33	40.5	62.1	15.6	46.5	54.0	-7.5
V	15372.288	51.7	33	37.7	56.4	15.6	40.8	54.0	-13.2

Polarization	Frequency (MHz)	Reading (dB μ V/m)	Pre-Amp Gain (dB)	Antenna Factor (dB)	Net at 3m - Peak (dB μ V/m)	Peak Limit at 3m (dB μ V/m)	Margin (dB)
H	3843.072	62.2	33	33.3	62.5	74.0	-11.5
H	5764.608	59.8	33	36.6	63.4	74.0	-10.6
H	7686.144	62.0	33	38.9	67.9	74.0	-6.1
V	9607.680	55.6	33	40.4	63.0	74.0	-11.0
V	11529.216	54.6	33	40.5	62.1	74.0	-11.9
V	15372.288	51.7	33	37.7	56.4	74.0	-17.6

NOTES:

1. Peak detector is used for the emission measurement over 1000 MHz.
2. All measurements were made at 3 meters.
3. Negative value in the margin column shows emission below limit.

INTERTEK TESTING SERVICES

Company: VTech Telecommunications Ltd.
Model: CL81109
Mode: Transmission

Date of Test: November 13-24, 2008

Table 3, Base Unit

Radiated Emissions Data
Pursuant To FCC Part 15 Section 15.323 (d) Emissions Requirements

Highest Channel:

Polarization	Frequency (MHz)	Measured Power (dBm)	Power Limit (dBm)	Margin (dB)
V	1930.015	-45.3	-9.5	-35.8
V	1931.265	-50.1	-29.5	-20.6
V	1933.089	-52.0	-39.5	-12.5

NOTES:

1. Peak detector is used for the emission measurement.
2. All measurements were made at 3 meters.
3. Negative value in the margin column shows emission below limit.

INTERTEK TESTING SERVICES

Company: VTech Telecommunications Ltd.
Model: CL81109
Mode: Transmission

Date of Test: November 13-24, 2008

Table 4, Base Unit

Radiated Emissions Data Pursuant To FCC Part 15 Section 15.209 Emissions Requirements

Highest Channel:

Polarization	Frequency (MHz)	Reading (dB μ V/m)	Pre-Amp Gain (dB)	Antenna Factor (dB)	Net at 3m - Peak (dB μ V/m)	Average Factor (dB)	Calculated at 3m (dB μ V/m)	Average Limit at 3m (dB μ V/m)	Margin (dB)
H	3856.896	62.1	33	33.3	62.4	15.6	46.8	54.0	-7.2
H	5785.344	60.0	33	36.6	63.6	15.6	48.0	54.0	-6.0
H	7713.792	62.0	33	38.9	67.9	15.6	52.3	54.0	-1.7
V	9642.240	55.8	33	40.4	63.2	15.6	47.6	54.0	-6.4
V	11570.688	54.6	33	40.5	62.1	15.6	46.5	54.0	-7.5
V	15427.584	51.5	33	37.7	56.2	15.6	40.6	54.0	-13.4

Polarization	Frequency (MHz)	Reading (dB μ V/m)	Pre-Amp Gain (dB)	Antenna Factor (dB)	Net at 3m - Peak (dB μ V/m)	Peak Limit at 3m (dB μ V/m)	Margin (dB)
H	3856.896	62.1	33	33.3	62.4	74.0	-11.6
H	5785.344	60.0	33	36.6	63.6	74.0	-10.4
H	7713.792	62.0	33	38.9	67.9	74.0	-6.1
V	9642.240	55.8	33	40.4	63.2	74.0	-10.8
V	11570.688	54.6	33	40.5	62.1	74.0	-11.9
V	15427.584	51.5	33	37.7	56.2	74.0	-17.8

NOTES:

1. Peak detector is used for the emission measurement over 1000 MHz.
2. All measurements were made at 3 meters.
3. Negative value in the margin column shows emission below limit.

INTERTEK TESTING SERVICES

Company: VTech Telecommunications Ltd.
Model: CL81109
Mode: Talk

Date of Test: November 13-24, 2008

Table 5, Base Unit

**Radiated Emissions Data
Pursuant To FCC Part 15 Section 15.323 (d) Emissions Requirements**

Polarization	Frequency (MHz)	Measured Power (dBm)	Power Limit (dBm)	Margin (dB)
V	55.200	-61.6	-39.5	-22.1
V	110.400	-61.3	-39.5	-21.8
H	165.600	-61.1	-39.5	-21.6
H	220.800	-61.0	-39.5	-21.5
H	276.000	-62.3	-39.5	-22.8
H	331.200	-63.1	-39.5	-23.6

NOTES:

1. Peak detector is used for the emission measurement.
2. All measurements were made at 3 meters.
3. Negative value in the margin column shows emission below limit.

INTERTEK TESTING SERVICES

Company: VTech Telecommunications Ltd.
Model: CL82109
Mode: Transmission

Date of Test: November 13-24, 2008

Table 6, Base Unit

Radiated Emissions Data
Pursuant To FCC Part 15 Section 15.323 (d) Emissions Requirements

Lowest Channel:

Polarization	Frequency (MHz)	Measured Power (dBm)	Power Limit (dBm)	Margin (dB)
V	1919.721	-42.8	-9.5	-33.3
V	1918.608	-49.3	-29.5	-19.8
V	1917.084	-51.6	-39.5	-12.1

NOTES:

1. Peak detector is used for the emission measurement.
2. All measurements were made at 3 meters.
3. Negative value in the margin column shows emission below limit.

INTERTEK TESTING SERVICES

Company: VTech Telecommunications Ltd.
 Model: CL82109
 Mode: Transmission

Date of Test: November 13-24, 2008

Table 7, Base Unit

Radiated Emissions Data Pursuant To FCC Part 15 Section 15.209 Emissions Requirements

Lowest Channel:

Polarization	Frequency (MHz)	Reading (dBμV)	Pre-Amp Gain (dB)	Antenna Factor (dB)	Net at 3m - Peak (dBμV/m)	Average Factor (dB)	Calculated at 3m (dBμV/m)	Average Limit at 3m (dBμV/m)	Margin (dB)
H	3843.072	61.1	33	33.3	61.4	15.6	45.8	54.0	-8.2
H	5764.608	59.2	33	36.6	62.8	15.6	47.2	54.0	-6.8
H	7686.144	62.0	33	38.9	67.9	15.6	52.3	54.0	-1.7
V	9607.680	55.8	33	40.4	63.2	15.6	47.6	54.0	-6.4
V	11529.216	57.3	33	40.5	64.8	15.6	49.2	54.0	-4.8
V	15372.288	52.8	33	37.7	57.5	15.6	41.9	54.0	-12.1

Polarization	Frequency (MHz)	Reading (dBμV)	Pre-Amp Gain (dB)	Antenna Factor (dB)	Net at 3m - Peak (dBμV/m)	Peak Limit at 3m (dBμV/m)	Margin (dB)
H	3843.072	61.1	33	33.3	61.4	74.0	-12.6
H	5764.608	59.2	33	36.6	62.8	74.0	-11.2
H	7686.144	62.0	33	38.9	67.9	74.0	-6.1
V	9607.680	55.8	33	40.4	63.2	74.0	-10.8
V	11529.216	57.3	33	40.5	64.8	74.0	-9.2
V	15372.288	52.8	33	37.7	57.5	74.0	-16.5

NOTES:

1. Peak detector is used for the emission measurement over 1000 MHz.
2. All measurements were made at 3 meters.
3. Negative value in the margin column shows emission below limit.

INTERTEK TESTING SERVICES

Company: VTech Telecommunications Ltd.
Model: CL82109
Mode: Transmission

Date of Test: November 13-24, 2008

Table 8, Base Unit

Radiated Emissions Data
Pursuant To FCC Part 15 Section 15.323 (d) Emissions Requirements

Highest Channel:

Polarization	Frequency (MHz)	Measured Power (dBm)	Power Limit (dBm)	Margin (dB)
V	1930.015	-42.1	-9.5	-32.6
V	1931.265	-49.4	-29.5	-19.9
V	1933.089	-51.8	-39.5	-12.3

NOTES:

1. Peak detector is used for the emission measurement.
2. All measurements were made at 3 meters.
3. Negative value in the margin column shows emission below limit.

INTERTEK TESTING SERVICES

Company: VTech Telecommunications Ltd.
Model: CL82109
Mode: Transmission

Date of Test: November 13-24, 2008

Table 9, Base Unit

Radiated Emissions Data Pursuant To FCC Part 15 Section 15.209 Emissions Requirements

Highest Channel:

Polarization	Frequency (MHz)	Reading (dB μ V)	Pre-Amp Gain (dB)	Antenna Factor (dB)	Net at 3m - Peak (dB μ V/m)	Average Factor (dB)	Calculated at 3m (dB μ V/m)	Average Limit at 3m (dB μ V/m)	Margin (dB)
H	3856.896	61.0	33	33.3	61.3	15.6	45.7	54.0	-8.3
H	5785.344	58.8	33	36.6	62.4	15.6	46.8	54.0	-7.2
H	7713.792	61.7	33	38.9	67.6	15.6	52.0	54.0	-2.0
V	9642.240	56.0	33	40.4	63.4	15.6	47.8	54.0	-6.2
V	11570.688	56.7	33	40.5	64.2	15.6	48.6	54.0	-5.4
V	15427.584	52.5	33	37.7	57.2	15.6	41.6	54.0	-12.4

Polarization	Frequency (MHz)	Reading (dB μ V)	Pre-Amp Gain (dB)	Antenna Factor (dB)	Net at 3m - Peak (dB μ V/m)	Peak Limit at 3m (dB μ V/m)	Margin (dB)
H	3856.896	61.0	33	33.3	61.3	74.0	-12.7
H	5785.344	58.8	33	36.6	62.4	74.0	-11.6
H	7713.792	61.7	33	38.9	67.6	74.0	-6.4
V	9642.240	56.0	33	40.4	63.4	74.0	-10.6
V	11570.688	56.7	33	40.5	64.2	74.0	-9.8
V	15427.584	52.5	33	37.7	57.2	74.0	-16.8

NOTES:

1. Peak detector is used for the emission measurement over 1000 MHz.
2. All measurements were made at 3 meters.
3. Negative value in the margin column shows emission below limit.

INTERTEK TESTING SERVICES

Company: VTech Telecommunications Ltd.
Model: CL82109
Mode: Talk

Date of Test: November 13-24, 2008

Table 10, Base Unit

Radiated Emissions Data
Pursuant To FCC Part 15 Section 15.323 (d) Emissions Requirements

Polarization	Frequency (MHz)	Measured Power (dBm)	Power Limit (dBm)	Margin (dB)
V	55.300	-61.6	-39.5	-22.1
V	110.600	-61.3	-39.5	-21.8
H	165.900	-61.1	-39.5	-21.6
H	221.200	-61.0	-39.5	-21.5
H	276.500	-61.8	-39.5	-22.3
H	331.800	-62.6	-39.5	-23.1

NOTES:

1. Peak detector is used for the emission measurement.
2. All measurements were made at 3 meters.
3. Negative value in the margin column shows emission below limit.

INTERTEK TESTING SERVICES

Company: VTech Telecommunications Ltd.
Model: CL82109
Mode: Transmission

Date of Test: November 13-24, 2008

Table 11, Handset

Radiated Emissions Data
Pursuant To FCC Part 15 Section 15.323 (d) Emissions Requirements

Lowest Channel:

Polarization	Frequency (MHz)	Measured Power (dBm)	Power Limit (dBm)	Margin (dB)
V	1919.720	-44.4	-9.5	-34.9
V	1918.608	-49.3	-29.5	-19.8
V	1917.085	-51.6	-39.5	-12.1

NOTES:

1. Peak detector is used for the emission measurement.
2. All measurements were made at 3 meters.
3. Negative value in the margin column shows emission below limit.

INTERTEK TESTING SERVICES

Company: VTech Telecommunications Ltd.
Model: CL82109
Mode: Transmission

Date of Test: November 13-24, 2008

Table 12, Handset

Radiated Emissions Data Pursuant To FCC Part 15 Section 15.209 Emissions Requirements

Lowest Channel:

Polarization	Frequency (MHz)	Reading (dB μ V/m)	Pre-Amp Gain (dB)	Antenna Factor (dB)	Net at 3m - Peak (dB μ V/m)	Average Factor (dB)	Calculated at 3m (dB μ V/m)	Average Limit at 3m (dB μ V/m)	Margin (dB)
H	3843.064	68.6	33	33.3	68.9	28.2	40.7	54.0	-13.3
H	5764.596	61.8	33	36.6	65.4	28.2	37.2	54.0	-16.8
H	7686.128	60.8	33	38.9	66.7	28.2	38.5	54.0	-15.5
H	9607.660	57.8	33	40.4	65.2	28.2	37.0	54.0	-17.0
V	11529.192	54.8	33	40.5	62.3	28.2	34.1	54.0	-19.9
V	15372.256	53.9	33	37.7	58.6	28.2	30.4	54.0	-23.6

Polarization	Frequency (MHz)	Reading (dB μ V/m)	Pre-Amp Gain (dB)	Antenna Factor (dB)	Net at 3m - Peak (dB μ V/m)	Peak Limit at 3m (dB μ V/m)	Margin (dB)
H	3843.064	68.6	33	33.3	68.9	74.0	-5.1
H	5764.596	61.8	33	36.6	65.4	74.0	-8.6
H	7686.128	60.8	33	38.9	66.7	74.0	-7.3
H	9607.660	57.8	33	40.4	65.2	74.0	-8.8
V	11529.192	54.8	33	40.5	62.3	74.0	-11.7
V	15372.256	53.9	33	37.7	58.6	74.0	-15.4

NOTES:

1. Peak detector is used for the emission measurement over 1000 MHz.
2. All measurements were made at 3 meters.
3. Negative value in the margin column shows emission below limit.

INTERTEK TESTING SERVICES

Company: VTech Telecommunications Ltd.
Model: CL82109
Mode: Transmission

Date of Test: November 13-24, 2008

Table 13, Handset

Radiated Emissions Data
Pursuant To FCC Part 15 Section 15.323 (d) Emissions Requirements

Highest Channel:

Polarization	Frequency (MHz)	Measured Power (dBm)	Power Limit (dBm)	Margin (dB)
V	1930.015	-44.6	-9.5	-35.1
V	1931.285	-49.4	-29.5	-19.9
V	1933.086	-52.0	-39.5	-12.5

NOTES:

1. Peak detector is used for the emission measurement.
2. All measurements were made at 3 meters.
3. Negative value in the margin column shows emission below limit.

INTERTEK TESTING SERVICES

Company: VTech Telecommunications Ltd.
Model: CL82109
Mode: Transmission

Date of Test: November 13-24, 2008

Table 14, Handset

Radiated Emissions Data Pursuant To FCC Part 15 Section 15.209 Emissions Requirements

Highest Channel:

Polarization	Frequency (MHz)	Reading (dB μ V/m)	Pre-Amp Gain (dB)	Antenna Factor (dB)	Net at 3m - Peak (dB μ V/m)	Average Factor (dB)	Calculated at 3m (dB μ V/m)	Average Limit at 3m (dB μ V/m)	Margin (dB)
H	3856.892	68.6	33	33.3	68.9	28.2	40.7	54.0	-13.3
H	5785.338	61.8	33	36.6	65.4	28.2	37.2	54.0	-16.8
H	7713.784	60.9	33	38.9	66.8	28.2	38.6	54.0	-15.4
H	9642.230	57.8	33	40.4	65.2	28.2	37.0	54.0	-17.0
V	11570.676	54.9	33	40.5	62.4	28.2	34.2	54.0	-19.8
V	15427.568	54.2	33	37.7	58.9	28.2	30.7	54.0	-23.3

Polarization	Frequency (MHz)	Reading (dB μ V/m)	Pre-Amp Gain (dB)	Antenna Factor (dB)	Net at 3m - Peak (dB μ V/m)	Peak Limit at 3m (dB μ V/m)	Margin (dB)
H	3856.892	68.6	33	33.3	68.9	74.0	-5.1
H	5785.338	61.8	33	36.6	65.4	74.0	-8.6
H	7713.784	60.9	33	38.9	66.8	74.0	-7.2
H	9642.230	57.8	33	40.4	65.2	74.0	-8.8
V	11570.676	54.9	33	40.5	62.4	74.0	-11.6
V	15427.568	54.2	33	37.7	58.9	74.0	-15.1

NOTES:

1. Peak detector is used for the emission measurement over 1000 MHz.
2. All measurements were made at 3 meters.
3. Negative value in the margin column shows emission below limit.

INTERTEK TESTING SERVICES

Company: VTech Telecommunications Ltd.
Model: CL82109
Mode: Talk

Date of Test: November 13-24, 2008

Table 15, Handset

Radiated Emissions Data
Pursuant To FCC Part 15 Section 15.323 (d) Emissions Requirements

Polarization	Frequency (MHz)	Measured Power (dBm)	Power Limit (dBm)	Margin (dB)
V	55.300	-61.4	-39.5	-21.9
V	82.950	-61.6	-39.5	-22.1
H	110.600	-62.3	-39.5	-22.8
H	138.250	-61.0	-39.5	-21.5
H	193.550	-61.1	-39.5	-21.6
H	248.850	-61.8	-39.5	-22.3
H	304.150	-62.6	-39.5	-23.1

NOTES:

1. Peak detector is used for the emission measurement.
2. All measurements were made at 3 meters.
3. Negative value in the margin column shows emission below limit.

INTERTEK TESTING SERVICES

Company: VTech Telecommunications Ltd.
Model: CL81109, CL82109

Date of Test: November 13-24, 2008

4.5.3 Field Strength Calculation

The field strength is calculated by adding the reading on the Spectrum Analyzer to the factors associated with preamplifiers (if any), antennas, cables, pulse desensitization and average factors (when specified limit is in average and measurements are made with peak detectors). A sample calculation is included below.

$$FS = RA + AF + CF - AG + PD + AV$$

Where

- FS = Field Strength in dB μ V/m
- RA = Receiver Amplitude (including preamplifier) in dB μ V
- CF = Cable Attenuation Factor in dB
- AF = Antenna Factor in dB
- AG = Amplifier Gain in dB
- PD = Pulse Desensitization in dB
- AV = Average Factor in -dB

In the radiated emission table which follows, the reading shown on the data table may reflect the preamplifier gain. An example of the calculations, where the reading does not reflect the preamplifier gain, follows:

$$FS = RA + AF + CF - AG + PD + AV$$

Example

Assume a receiver reading of 62.0 dB μ V is obtained. The antenna factor of 7.4 dB and cable factor of 1.6 dB is added. The amplifier gain of 29.0 dB is subtracted. The pulse desensitization factor of the spectrum analyzer is 0.0 dB, and the resultant average factor is -10.0 dB. The net field strength for comparison to the appropriate emission limit is 32.0 dB μ V/m. This value in dB μ V/m is converted to its corresponding level in μ V/m.

RA = 62.0 dB μ V
AF = 7.4 dB
CF = 1.6 dB
AG = 29.0 dB
PD = 0.0 dB
AV = -10 dB

$$FS = 62.0 + 7.4 + 1.6 - 29.0 + 0.0 + (-10.0) = 32.0 \text{ dB}\mu\text{V/m}$$

$$\text{Level in mV/m} = \text{Common Antilogarithm} [(32.0 \text{ dB}\mu\text{V/m})/20] = 39.8 \mu\text{V/m}$$

INTERTEK TESTING SERVICES

Company: VTech Telecommunications Ltd.
Model: CL81109, CL82109

Date of Test: November 13-24, 2008

4.5.4 Transmitter Duty Cycle Calculation and Measurements, FCC Rule 15.35(b), (c)

The EUT antenna output port was connected to the input of the spectrum analyzer. The analyzer center frequency was set to EUT RF channel carrier. The SPAN function on the analyzer was set to ZERO. The transmitter ON time was determined from the resultant time-amplitude display:

Base Unit: (for four handsets, single-slot operation with dummy)

$$\begin{aligned}\text{Duty cycle (DC)} &= \text{Maximum ON time in 10ms/10ms} \\ &= (4 \times 1 \times 0.388\text{ms} + 0.102\text{ms})/10\text{ms}\end{aligned}$$

$$\begin{aligned}\text{Average Factor (AF), dB} &= 20 \times \log(\text{DC}) \\ &= 20 \times \log(0.1654) \\ &= -15.6\text{dB}\end{aligned}$$

Handset: (for single-slot operation)

$$\begin{aligned}\text{Duty cycle (DC)} &= \text{Maximum ON time in 10ms/10ms} \\ &= (1 \times 0.388\text{ms})/10\text{ms}\end{aligned}$$

$$\begin{aligned}\text{Average Factor (AF), dB} &= 20 \times \log(\text{DC}) \\ &= 20 \times \log(0.0388) \\ &= -28.2\text{dB}\end{aligned}$$

[x] Please refer to the attached plots for more details:

Base Unit:

Plot B5A: Transmitter ON Time Measurements (Traffic Carrier)

Plot B5B: Transmitter ON Time Measurements (Dummy Carrier)

Handset

Plot H5A: Transmitter ON Time Measurements (Traffic Carrier)

The plots of Transmitter ON Time Measurements are saved as filename:
dcc.pdf

[] Please refer to the attached transmitter timing diagram that are provided by manufacturer

[] Not applicable - No average factor is required.

[] Please refer to Exhibit 2.2 Technical Description for more details

INTERTEK TESTING SERVICES

Company: VTech Telecommunications Ltd.
Model: CL81109, CL82109

Date of Test: November 13-24, 2008

4.6 AC Power Lines Conducted Emissions from Transmitter portion of EUT, FCC Rule 15.315:

The AC power lines conducted emission shall not exceed the limits of FCC Rule 15.207.

Measurements are made in accordance with ANSI C63.4 sub-clause 7. Emissions that are directly caused by digital circuits in the transmit path and transmitter portion are measured.

- Not applicable – EUT is only powered by battery for operation.
- EUT connects to AC power lines. Emission Data are listed in following pages. Please refer to the section 4.6.1 to 4.6.2 for more details.

INTERTEK TESTING SERVICES

Company: VTech Telecommunications Ltd.
Model: CL81109, CL82109
Mode: Talk

Date of Test: November 13-24, 2008

4.6.1 AC Power Lines Conducted Emissions Configuration Photographs:

Worst Case AC Power Line Conducted Emission

The worst case AC power Line conducted emission configuration photographs are saved as filename: config photos.pdf

INTERTEK TESTING SERVICES

Company: VTech Telecommunications Ltd.
Model: CL81109, CL82109
Mode: Talk

Date of Test: November 13-24, 2008

4.6.2 AC Power Line Conducted Emissions Data:

The data on the following pages list the significant emission frequencies, the limit, and the margin of compliance.

Judgment: Passed by more than 20 dB margin

The worst case AC power line conducted emission data are saved as filename: conduct.pdf

TEST ENGINEER:



Signature

Ken Sit, Assistant Manager
Typed/Printed Name

December 12, 2008
Date

INTERTEK TESTING SERVICES

Company: VTech Telecommunications Ltd.
Model: CL81109, CL82109

Date of Test: November 13-24, 2008

4.7 Radio Frequency Radiation Exposure, FCC Rule 15.319(i):

EUT is subject to the radio frequency exposure requirements specified in FCC Rule §§ 1.1307(b), 2.1091 and 2.1093. It shall be considered to operate in a “general population / uncontrolled” environment.

- [x] Handset Unit: EUT was evaluated for Specific Absorption Rate (SAR) evaluation compliance according to OET Bulletin 65, Supplement C (Edition 01-01). It is in compliance with the SAR evaluation requirements. The caution statement specified in the user manual. A SAR test report was submitted at the same time and saved as SAR Report.pdf

- [x] Base Unit: EUT was evaluated for Maximum Permissible Exposure (MPE) evaluation compliance according to OET Bulletin 65, Supplement C (Edition 01-01). The evaluation calculation results are saved as filename: RF exposure info.pdf.

INTERTEK TESTING SERVICES

Company: VTech Telecommunications Ltd.
Model: CL81109, CL82109

Date of Test: November 13-24, 2008

4.8 Monitoring Antenna, FCC Rule 15.323(c)(8):

The monitoring system shall use the same antenna used for transmission, or an antenna that yields equivalent reception at that location.

- EUT uses the same antenna used for transmission and monitoring that is in compliance meet above provision.
- EUT uses difference antenna used for transmission and monitoring. It must be verified that the monitoring antenna provides coverage equivalent to that of the transmitting antenna. Measurements are made in accordance with ANSI C63.17 sub-clause 4.

INTERTEK TESTING SERVICES

**EXHIBIT 5
EQUIPMENT PHOTOGRAPHS**

INTERTEK TESTING SERVICES

5.0 Equipment Photographs

The photographs are saved as filename: external photos.pdf & internal photos.pdf

**EXHIBIT 6
PRODUCT LABELLING**

INTERTEK TESTING SERVICES

6.0 Product Labelling

The FCC ID label artwork and its location are saved as filename: label.pdf

The label location justification letter is saved as filename: justification.pdf

**EXHIBIT 7
TECHNICAL SPECIFICATIONS**

INTERTEK TESTING SERVICES

7.0 Technical Specifications

The block diagram and circuit diagram are saved as filename: block.pdf and circuit.pdf respectively.

**EXHIBIT 8
INSTRUCTION MANUAL**

INTERTEK TESTING SERVICES

8.0 Instruction Manual

A preliminary copy of the Instruction Manual is saved as filename: manual.pdf

The required FCC Information to the User is stated at the Appendix of Instruction Manual for Model: CL81109 and CL82109.

This manual will be provided to the end-user with each unit sold/leased in the United States.

INTERTEK TESTING SERVICES

EXHIBIT 9 LETTER OF AGENCY

INTERTEK TESTING SERVICES

9.0 Letter of Agency

A copy of the Letter of Agency is saved as filename: letter of agency.pdf

INTERTEK TESTING SERVICES

**EXHIBIT 10
CONFIDENTIALITY REQUEST**

INTERTEK TESTING SERVICES

10.0 Confidentiality Request

A copy of the Confidentiality Request is saved as filename: request.pdf