



at&t

User's manual

TL7610/TL7611

DECT 6.0 cordless headset



Congratulations

on your purchase
of this AT&T product.

Before using this AT&T product, please
read the **Important safety information**
on pages 46-49 of this manual.

Please thoroughly read this user's
manual for all the feature operations
and troubleshooting information necessary
to install and operate your new
AT&T product. You can also visit our
website at **www.telephones.att.com** or call
1 (800) 222-3111.

In Canada, dial **1 (866) 288-4268.**

Model #: TL7610 (Headset and headset base)
TL7611 (Headset, headset base and handset lifter)
Type: DECT 6.0 cordless headset

Serial # : _____

Purchase date : _____

Place of purchase : _____

Both the model and serial number of your AT&T product can be
found on the bottom of the headset base.

Save your sales receipt and original packaging in case it is
necessary to return your telephone for warranty service.



ENERGY STAR

The ENERGY STAR[®] program (www.energystar.gov) recognizes
and encourages the use of products that save energy and
help protect our environment. We are proud to mark this
product with the ENERGY STAR[®] label indicating it meets the
latest energy efficiency guidelines.

© 2008 Advanced American Telephones. All rights reserved.

AT&T and the AT&T logo are trademarks of AT&T Intellectual Property II, L.P. d/b/a
AT&T Intellectual Property licensed to Advanced American Telephones.

Printed in China.

Parts checklist - TL7610

Check to make sure the headset package includes the following items:

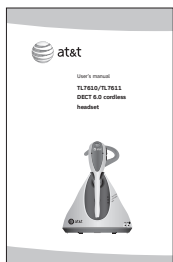

User's manual

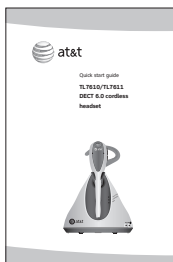

Quick start guide



Cordless headset

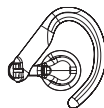

Over-the-ear hook

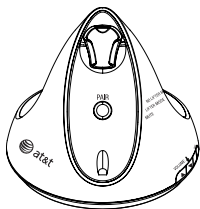

Headset base



Battery compartment cover



Battery for headset



Telephone line cords (2-conductor)



Headset base power adapter



Behind-the-neckband



Over-the-headband



Line splitter

Parts checklist - TL7611

Check to make sure the headset package includes the following items:

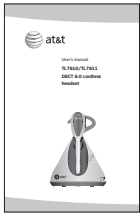

TL7610/7611 User's manual



TL7000 User's manual

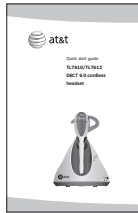

TL7610/7611 Quick start guide



Cordless headset



Over-the-ear hook

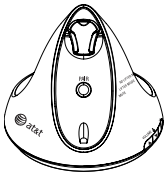

Headset base



Battery compartment cover



Battery for headset



Telephone line cords (4-conductor and 2-conductor)



Headset base power adapter



Behind-the-neckband



Over-the-headband



Line splitter

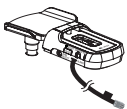

Remote handset lifter



Ring detector



Large lifter pad



Anti-slip pad



Color label (light blue)

User's manual

TL7610/TL7611

DECT 6.0 cordless headset



Table of contents

Getting started

Quick reference guide	
headset	1
headset base	2
Installation preparation	4
Headset base installation	5
Battery installation	10
Battery charging	11
Headset attachments	12

Operation

Headset base settings	20
Headset operation	21
Options while on calls	24
Alert tones	27
Indicator lights	28

Registration and de-registration

Adding and registering	
headset	30
Replacing a headset	32

Maintenance and Troubleshooting

Troubleshooting	34
Important safety	
information	46
Maintenance	50

Appendix A

FCC Part 68 and ACTA	51
----------------------------	----

Appendix B

FCC Part 15	54
-------------------	----

Appendix C

Limited warranty	56
Technical specifications	60

Index

Index	61
-------------	----

Quick reference guide - headset



ON/OFF

Press to make, answer and end a call.

The light is on when the headset is charging in the headset base.

The light flashes when you are on a call or when there is an incoming call (page 28).

VOLUME ? ▲▼

Press the volume key on the side of the headset to adjust the listening volume when on a call.

MUTE/FLASH

Press to mute the microphone during a call (page 26).

Press and hold to receive call waiting during a call (page 25).

Press to mute the ring tone in the earpiece when there is an incoming call.

Battery cover

Open to install or replace the battery.

Microphone

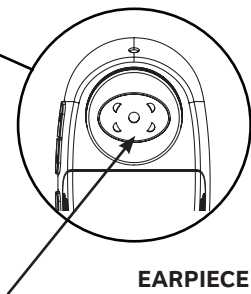

EARPIECE

Quick reference guide - headset base

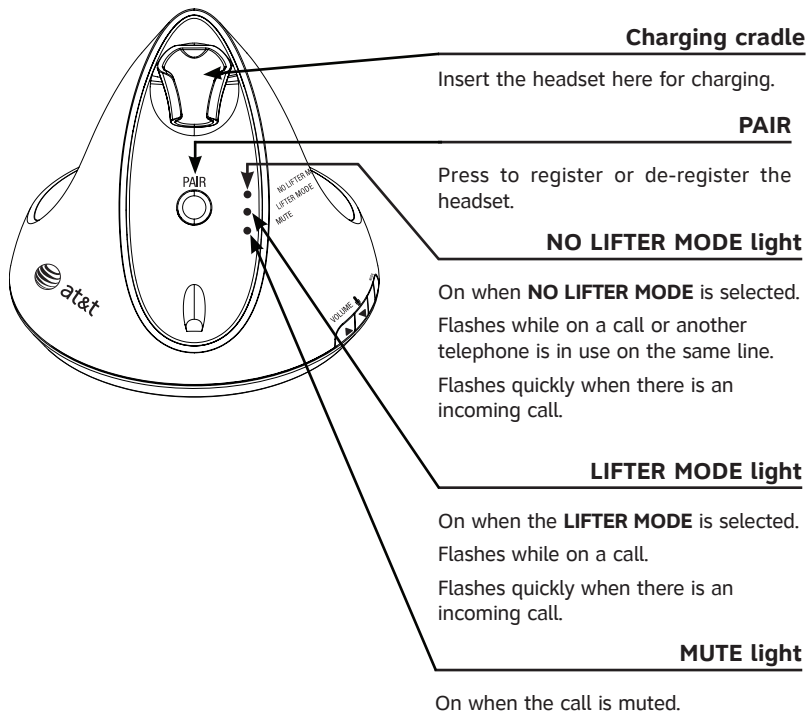

Quick reference guide - headset base

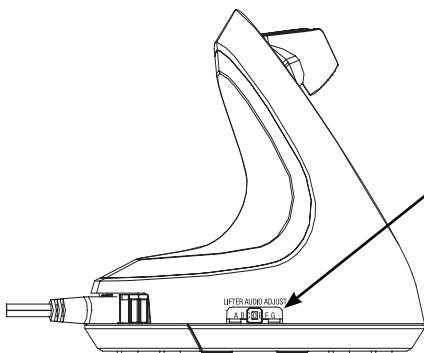

LIFTER AUDIO ADJUST

Adjust the switch to choose the best headset audio quality when using a handset lifter. (See the handset lifter user's manual for more information. You may download the manual at

www.telephones.att.com.)

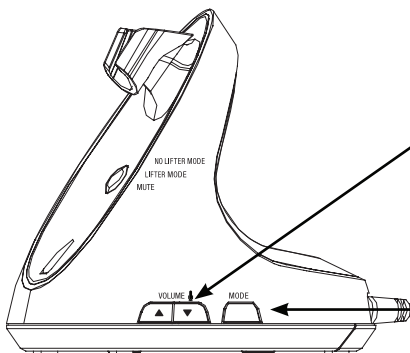

VOLUME ▲▼

Press the volume keys on the side of the headset base to adjust the speaking volume when on a call.

MODE

Press to choose between the **NO LIFTER** or **LIFTER MODE** when the headset is not in use. The corresponding light will come on (see page 20).

Installation preparation

You must install and charge the battery before using the headset.



See pages 10-11 for easy instructions.

If you subscribe to high-speed Internet service (Digital Subscriber Line - DSL) through your telephone lines, you must install a DSL filter between the telephone line cord and the telephone wall jack. The filter will prevent noise and caller ID problems caused by DSL interference. Please contact your DSL service provider for more information about DSL filters.

For customer service or product information, visit our website at **www.telephones.att.com** or call **1 (800) 222-3111**. In Canada, dial **1 (866) 288-4268**.

Avoid placing the headset base too close to:

- Communication devices such as: television sets, VCRs, or other cordless telephones.
- Excessive heat sources.
- Noise sources such as a window with traffic outside, motors, microwave ovens, refrigerators, or fluorescent lighting.
- Excessive dust sources such as a workshop or garage.
- Excessive moisture.
- Extremely low temperature.
- Mechanical vibration or shock such as on top of the washing machine or work bench.

Headset base installation

IMPORTANT: If you purchased model TL7611, see the TL7000 handset lifter manual for installation instructions.

Optional accessories

It is recommended that you install a handset lifter (model TL7000) and/or a dial pad (model TL7601) with your headset. The following optional accessories are compatible with your headset and base:

- The TL7000 is a handset lifter with ring detector.
- The TL7601 is a dial pad that allows you to dial numbers and place calls without being near your telephone. The dial pad will also allow you to use the headset as a stand-alone product without needing a connection to a telephone.
- The TL7600 is an expansion headset (up to two headsets can be used with the headset base).

Visit our website **www.telephones.att.com** for more information about these products or to download user manuals.

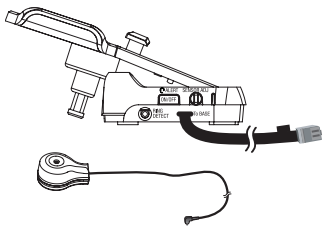

TL7000

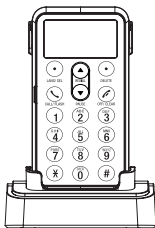

TL7601

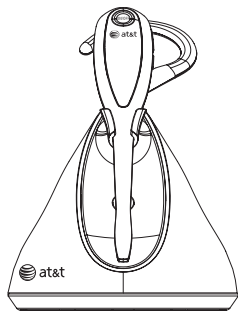

TL7600

Headset base installation

If you are installing the headset base with neither the lifter nor the dial pad, there are two installation options:

Option 1: You may use the headset as a stand-alone product without a phone.

- You will only be able to receive calls. If you want to make calls, an accessory dial pad (model TL7601, sold separately) is required.
- The headset base and headset do not have an external ringer. When you receive calls, the headset earpiece will play ring tone. If you have telephones connected to the same telephone line as the headset base, you can rely on the ringers of those telephones to alert you to incoming calls.

-OR-

Option 2: You may use the headset with a corded or cordless phone.

If you subscribe to high-speed Internet service (Digital Subscriber Line - DSL) through your telephone lines, you must install a DSL filter between the telephone base and the telephone wall jack. The filter will prevent noise and caller ID problems caused by DSL interference. Please contact your DSL service provider for more information about DSL filters.

Headset base installation

Before installing the headset base:

Remove the rear bottom piece of the headset base by pushing it away from the base (as shown in Figure 1).

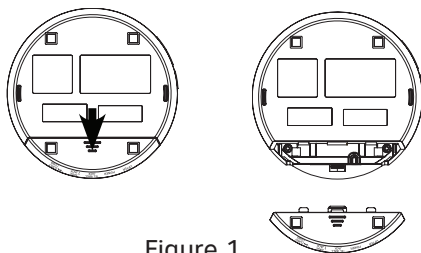

Figure 1

Install the headset base as shown on the following pages.

After completing installation option 1 or 2:

Slide the rear bottom piece towards the base until it clicks into place (as shown in Figure 2).

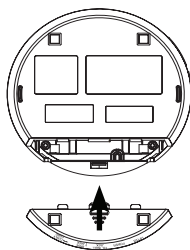

Figure 2

Headset base installation

Option 1: Headset base stand-alone installation (TL7610)

With this installation, you can receive calls only.

1. Plug the small end of the headset base power adapter into the **POWER** jack (green dot) at the back of the headset base.

2. Plug one end of the telephone line cord into the **TEL WALL JACK** (red dot) at the back of the headset base.

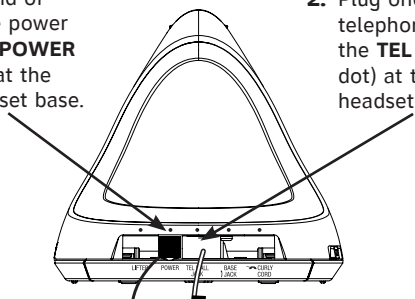

Telephone line cord

3. Plug the other end of the telephone line cord into a telephone jack.

4. Plug the headset base power adapter into an electrical outlet not controlled by a wall switch.

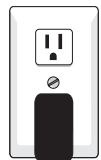

DSL filter (not included) required if you have DSL high-speed Internet service.

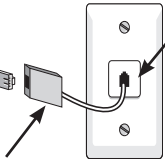

NOTE: For more information about the accessory dial pad (model TL7601), visit our website www.telephones.att.com.

Headset base installation

Option 2: Headset base with corded or cordless phone (any brand) installation (TL7610)

With this installation, you can make and receive calls using the corded or cordless phone.

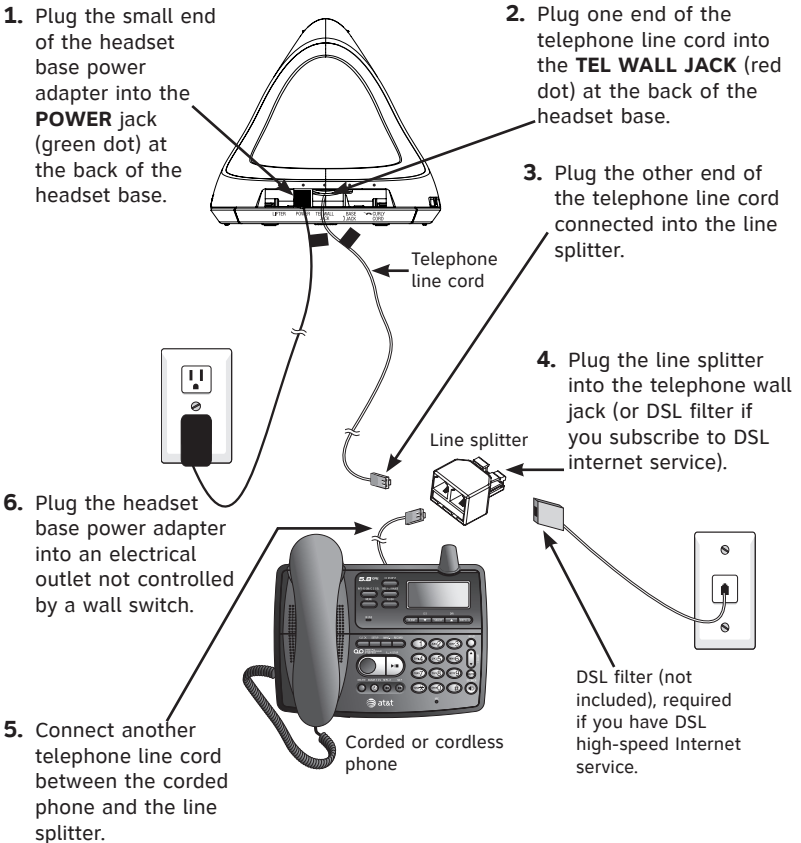

Battery installation

Install the battery as shown below. After installing the battery, you may be able to make and receive short calls. For optimal performance, charge the headset battery for at least six hours before use. When not in use, recharge the headset by returning it to the headset base.

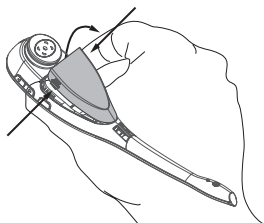

1. Press in on both sides of the battery compartment cover and lift the cover up and off.

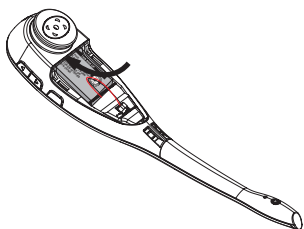

2. Insert the battery into the battery compartment.
3. Push the battery plug into the connector inside the compartment and lay the wires flat on top of the battery.

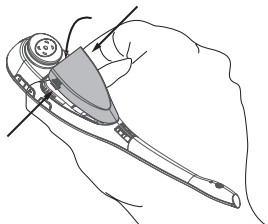

4. Insert the tab on the bottom of the battery cover into the battery compartment. Press down gently on the battery cover until it snaps into place.



NOTE: Remove the ear hook from the headset (see page 14) before battery replacement.