

	<u>Date(s) of Evaluation</u> July 13 & 16, 2007	<u>Test Report Serial No.</u> 062107EW7-T839-S15T	<u>Report Revision No.</u> Revision 1.0	 Certificate No. 2470.01
	<u>Test Report Issue Date</u> July 20, 2007	<u>Description of Test(s)</u> Specific Absorption Rate	<u>RF Exposure Category</u> General Population	

RF EXPOSURE EVALUATION

SPECIFIC ABSORPTION RATE

SAR TEST REPORT

FOR

VTECH TELECOMMUNICATIONS LTD.

PORTABLE 5.8 GHz CORDLESS TELEPHONE HANDSET

DEVICE IDENTIFIER(S)			
FCC ID:	EW780-6101-00	IC ID:	1135A-80610100
Class II Permissive Change:	Add Models LS5145, LS5105		
TEST STANDARD(S) & PROCEDURE(S) APPLIED			
FCC OET Bulletin 65, Supplement C (01-01)			
FCC OET SAR Measurement Requirements for 3 - 6 GHz			
Industry Canada RSS-102 Issue 2			
IEEE 1528-2003			

Test Report Serial No.

062107EW7-T839-S15T

Test Report Revision No.

Revision 1.0 (Initial Release)

Test Lab and Location



Celltech Compliance Testing & Engineering Lab
(Celltech Labs Inc.)
21-364 Loughheed Road
Kelowna, B.C. V1X 7R8
Canada



Certificate No. 2470.01

<u>Testing and Report By:</u> Cheri Frangiadakis Celltech Labs Inc.	<u>Test Report Reviewed By:</u> Jonathan Hughes Celltech Labs Inc.
---	--

Company:	VTECH TELECOMMUNICATIONS LTD.	FCC ID:	EW780-6101-00	IC ID:	1135A-80610100	
Model(s):	LS5145 / LS5105	Portable 5.8 GHz Cordless Telephone Handset	Freq.:	5744 - 5825 MHz		
2007 Celltech Labs Inc.		This document is not to be reproduced in whole or in part without the prior written permission of Celltech Labs Inc.				Page 1 of 49

	<u>Date(s) of Evaluation</u> July 13 & 16, 2007	<u>Test Report Serial No.</u> 062107EW7-T839-S15T	<u>Report Revision No.</u> Revision 1.0	 Certificate No. 2470.01
	<u>Test Report Issue Date</u> July 20, 2007	<u>Description of Test(s)</u> Specific Absorption Rate	<u>RF Exposure Category</u> General Population	

DECLARATION OF COMPLIANCE SAR RF EXPOSURE EVALUATION

<u>Test Lab and Location</u> CELLTECH LABS INCORPORATED Testing and Engineering Services 21-364 Lougheed Road Kelowna, B.C. V1X 7R8 Canada Tel.: 250-765-7650 Fax: 250-765-7645 e-mail: info@celltechlabs.com web site: www.celltechlabs.com		<u>Company Information</u> VTECH TELECOMMUNICATIONS LTD. 23/F Tai Ping Ind. Center Block 1 57 Ting Kok Rd. Tai Po, Hong Kong	
FCC IDENTIFIER:	EW780-6101-00	IC IDENTIFIER:	1135A-80610100
Model No.(s):	LS5145 / LS5105		
Standard(s) Applied:	FCC 47 CFR §2.1093; Health Canada Safety Code 6		
Procedure(s) Applied:	FCC OET Bulletin 65, Supplement C (01-01) FCC OET SAR Measurement Requirements for 3 - 6 GHz Industry Canada RSS-102 Issue 2 IEEE 1528-2003		
FCC Device Classification:	Part 15 Spread Spectrum Transmitter (DSS)		
IC Device Classification:	Low Power License-Exempt Radiocommunication Device (RSS-210)		
Application Type:	Class II Permissive Change (Add New Models LS5145, LS5105)		
Device Description:	Portable 5.8 GHz Cordless Telephone Handset		
Transmit Frequency Range(s):	5744 - 5825 MHz (ISM Band)		
Spread Spectrum Method:	Frequency Hopping		
Mode(s) of Operation:	TDMA/TDD (2 Uplink Slots)		
Max. Duty Cycle Tested:	20 % (Source-Based Time-Averaged)		
Max. RF Output Power Tested:	117.7 dBuV/m - Field Strength (5825.952 MHz)		
Battery Type(s) Tested:	Ni-MH 3.6 V, 550 mAh		
Antenna Type(s) Tested:	Internal		
Body-worn Accessories Tested:	n/a (handset does not have provision for body-worn transmit operation)		
Audio Accessories Tested:	n/a (handset does not have provision for audio accessory)		
Max. SAR Level(s) Evaluated:	Head: 1.57 W/kg (1g average)		

Celltech Labs Inc. declares under its sole responsibility that this wireless portable device is compliant with the Specific Absorption Rate (SAR) RF exposure requirements specified in FCC 47 CFR §2.1093 and Health Canada's Safety Code 6 for the General Population / Uncontrolled Exposure environment. The device was tested in accordance with the measurement standards and procedures specified in FCC OET Bulletin 65, Supplement C (Edition 01-01), FCC OET SAR Measurement Requirements for 3 - 6 GHz, Industry Canada RSS-102 Issue 2 and IEEE Standard 1528-2003. All measurements were performed in accordance with the SAR system manufacturer recommendations.

I attest to the accuracy of data. All measurements were performed by me or were made under my supervision and are correct to the best of my knowledge and belief. I assume full responsibility for the completeness of these measurements and vouch for the qualifications of all persons taking them.

This test report shall not be reproduced partially, or in full, without the prior written approval of Celltech Labs Inc. The results and statements contained in this report pertain only to the device(s) evaluated.

Test Report Approved By:

Sean Johnston
Celltech Labs Inc.



Company:	VTECH TELECOMMUNICATIONS LTD.	FCC ID:	EW780-6101-00	IC ID:	1135A-80610100	
Model(s):	LS5145 / LS5105	Portable 5.8 GHz Cordless Telephone Handset	Freq.:	5744 - 5825 MHz		
2007 Celltech Labs Inc.	This document is not to be reproduced in whole or in part without the prior written permission of Celltech Labs Inc.					Page 2 of 49

TABLE OF CONTENTS	
1.0 INTRODUCTION _____	4
2.0 DESCRIPTION of DEVICE UNDER TEST (DUT) _____	4
3.0 SAR MEASUREMENT SYSTEM _____	5
4.0 MEASUREMENT SUMMARY _____	6
5.0 DETAILS OF SAR EVALUATION _____	7
DETAILS OF SAR EVALUATION (Cont.) _____	8
6.0 EVALUATION PROCEDURES _____	8
EVALUATION PROCEDURES (Cont.) _____	9
7.0 SYSTEM PERFORMANCE CHECK _____	10
8.0 SIMULATED EQUIVALENT TISSUES _____	11
9.0 SAR SAFETY LIMITS _____	11
10.0 ROBOT SYSTEM SPECIFICATIONS _____	12
11.0 PROBE SPECIFICATION (EX3DV4) _____	13
12.0 SAM PHANTOM V4.0C _____	13
13.0 DEVICE HOLDER _____	13
14.0 TEST EQUIPMENT LIST _____	14
15.0 MEASUREMENT UNCERTAINTIES _____	15
MEASUREMENT UNCERTAINTIES (Cont.) _____	16
16.0 REFERENCES _____	17
APPENDIX A - SAR MEASUREMENT DATA _____	18
APPENDIX B - SYSTEM PERFORMANCE CHECK DATA _____	29
APPENDIX C - MEASURED FLUID DIELECTRIC PARAMETERS _____	34
APPENDIX D - MANUFACTURER'S TISSUE SIMULANT DATA SHEET _____	37
APPENDIX E - SAR TEST SETUP & DUT PHOTOGRAPHS _____	40
APPENDIX F - SYSTEM VALIDATION _____	47
APPENDIX G - PROBE CALIBRATION _____	48
APPENDIX H - SAM PHANTOM CERTIFICATE OF CONFORMITY _____	49

	<u>Date(s) of Evaluation</u> July 13 & 16, 2007	<u>Test Report Serial No.</u> 062107EW7-T839-S15T	<u>Report Revision No.</u> Revision 1.0	 Certificate No. 2470.01
	<u>Test Report Issue Date</u> July 20, 2007	<u>Description of Test(s)</u> Specific Absorption Rate	<u>RF Exposure Category</u> General Population	

1.0 INTRODUCTION

This measurement report demonstrates that the VTECH TELECOMMUNICATIONS LTD. Model(s): LS5145 / LS5105 Portable 5.8 GHz Cordless Telephone Handset complies with the SAR (Specific Absorption Rate) RF exposure requirements specified in FCC 47 CFR §2.1093 (see reference [1]) and Health Canada's Safety Code 6 (see reference [2]) for the General Population / Uncontrolled Exposure environment. The measurement procedures described in FCC OET Bulletin 65, Supplement C, Edition 01-01 (see reference [3]), FCC OET SAR Measurement Requirements for 3 - 6 GHz (see reference [7]), IC RSS-102 Issue 2 (see reference [4]), and IEEE Standard 1528-2003 (see reference [5]) were employed. A description of the product, operating configuration, detailed summary of the test results, methodology and procedures used in the evaluation, equipment used, and the various provisions of the rules are included within this test report.

2.0 DESCRIPTION of DEVICE UNDER TEST (DUT)

Standard(s) Applied	FCC	47 CFR §2.1093		
	IC	Health Canada Safety Code 6		
Procedure(s) Applied	FCC	OET Bulletin 65, Supplement C (01-01)		
		OET SAR Measurement Requirements for 3 - 6 GHz		
	IC	RSS-102 Issue 2		
Device Classification(s)	IEEE	1528-2003		
	FCC	Part 15 Spread Spectrum Transmitter (DSS)	FCC §15C	
	IC	Low Power License-Exempt Radiocommunication Device	RSS-210	
Device Description	Portable 5.8 GHz Cordless Telephone Handset			
RF Exposure Category	General Population / Uncontrolled Environment			
FCC IDENTIFIER	EW780-6101-00			
IC IDENTIFIER	1135A-80610100			
Model No.(s)	LS5145		LS5105	
Test Sample Serial No.	#2		Identical Prototype	
Mode(s) of Operation	TDMA / TDD			
Max. Duty Cycle Tested	20%	Source-Based Time-Averaged	2 Uplink Slots	Crest Factor: 1:5
Transmit Frequency Range	5744 - 5825 MHz (ISM Band)			
Max. RF Output Power Tested	113.3 dBuV/m	Field Strength	5744.736 MHz	
	116.3 dBuV/m	Field Strength	5785.344 MHz	
	117.7 dBuV/m	Field Strength	5825.952 MHz	
Antenna Type(s) Tested	Internal			
Battery Type(s) Tested	Ni-MH	3.6 V	550 mAh	
Body-worn Accessories Tested	n/a - handset does not have provision for body-worn transmit operation			
Audio Accessories Tested	n/a - handset does not have provision for audio accessory			
Application Type	Class II Permissive Change (Add New Models LS5145, LS5105)			

Company:	VTECH TELECOMMUNICATIONS LTD.	FCC ID:	EW780-6101-00	IC ID:	1135A-80610100	
Model(s):	LS5145 / LS5105	Portable 5.8 GHz Cordless Telephone Handset	Freq.:	5744 - 5825 MHz		
2007 Celltech Labs Inc.		This document is not to be reproduced in whole or in part without the prior written permission of Celltech Labs Inc.				Page 4 of 49

	<u>Date(s) of Evaluation</u> July 13 & 16, 2007	<u>Test Report Serial No.</u> 062107EW7-T839-S15T	<u>Report Revision No.</u> Revision 1.0	 Certificate No. 2470.01
	<u>Test Report Issue Date</u> July 20, 2007	<u>Description of Test(s)</u> Specific Absorption Rate	<u>RF Exposure Category</u> General Population	

3.0 SAR MEASUREMENT SYSTEM

Celltech Labs Inc. SAR measurement facility utilizes the Dosimetric Assessment System (DASY™) manufactured by Schmid & Partner Engineering AG (SPEAG™) of Zurich, Switzerland. The DASY4 measurement system is comprised of the measurement server, robot controller, computer, near-field probe, probe alignment sensor, specific anthropomorphic mannequin (SAM) phantom, and alternate planar phantoms for brain and/or body SAR evaluations. The robot is a six-axis industrial robot performing precise movements to position the probe to the location (points) of maximum electromagnetic field (EMF). A cell controller system contains the power supply, robot controller, teach pendant (Joystick), and remote control, is used to drive the robot motors. The Staubli robot is connected to the cell controller to allow software manipulation of the robot. A data acquisition electronic (DAE) circuit performs the signal amplification, signal multiplexing, AD-conversion, offset measurements, mechanical surface detection, collision detection, etc. is connected to the Electro-optical coupler (EOC). The EOC performs the conversion from the optical into digital electric signal of the DAE and transfers data to the DASY4 measurement server. The DAE4 utilizes a highly sensitive electrometer-grade preamplifier with auto-zeroing, a channel and gain-switching multiplexer, a fast 16-bit AD-converter and a command decoder and control logic unit. Transmission to the DASY4 measurement server is accomplished through an optical downlink for data and status information and an optical uplink for commands and clock lines. The mechanical probe-mounting device includes two different sensor systems for frontal and sidewise probe contacts. The sensor systems are also used for mechanical surface detection and probe collision detection. The robot uses its own controller with a built in VME-bus computer.

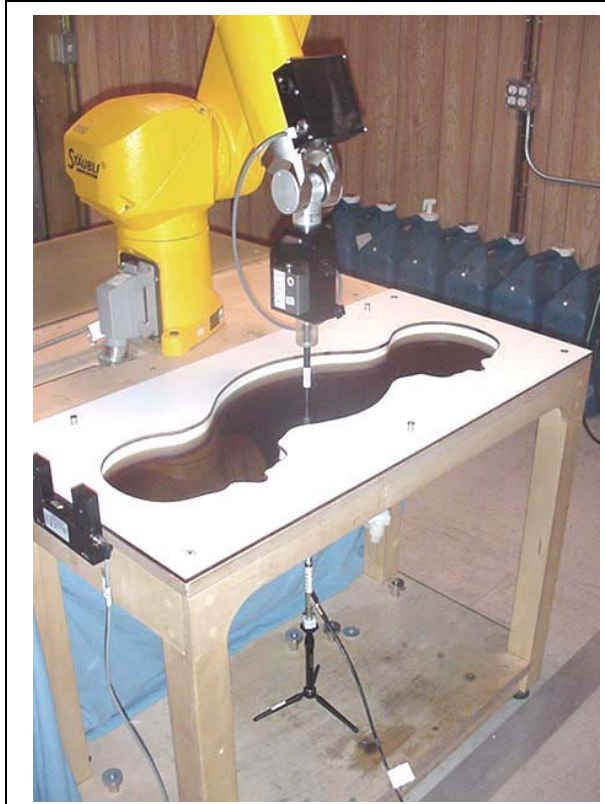

DASY4 Measurement System with SAM Phantom

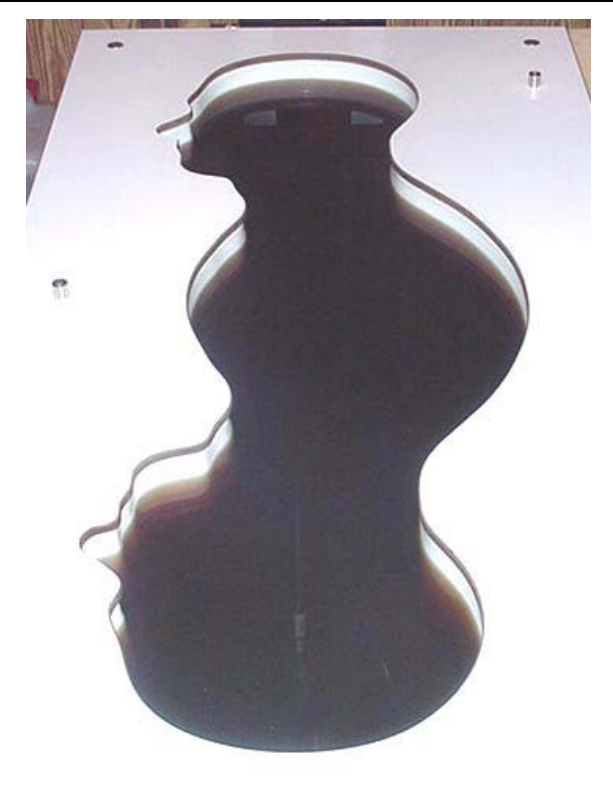

SAM Phantom with 5 GHz Tissue Simulant

Company:	VTECH TELECOMMUNICATIONS LTD.	FCC ID:	EW780-6101-00	IC ID:	1135A-80610100	
Model(s):	LS5145 / LS5105	Portable 5.8 GHz Cordless Telephone Handset		Freq.:	5744 - 5825 MHz	
2007 Celltech Labs Inc.		This document is not to be reproduced in whole or in part without the prior written permission of Celltech Labs Inc.				Page 5 of 49

	<u>Date(s) of Evaluation</u> July 13 & 16, 2007	<u>Test Report Serial No.</u> 062107EW7-T839-S15T	<u>Report Revision No.</u> Revision 1.0	 Certificate No. 2470.01
	<u>Test Report Issue Date</u> July 20, 2007	<u>Description of Test(s)</u> Specific Absorption Rate	<u>RF Exposure Category</u> General Population	

4.0 MEASUREMENT SUMMARY

HEAD SAR EVALUATION RESULTS

Test Date	Freq.	Chan.	Test Mode	Uplink Slots	Duty Cycle	Battery Type	Phantom Section	Test Position	DUT Start Power (F/S)	SAR Drift During Test	Measured SAR 1g
	MHz								dBuV/m	dB	W/kg
Jul-13	5785.344	47	TDMA/TDD	2	20 %	Ni-MH	Right Ear	Cheek/Touch	116.3	-0.0713	1.02
Jul-13	5785.344	47	TDMA/TDD	2	20 %	Ni-MH	Right Ear	Ear/Tilt (15°)	116.3	-0.0386	1.06
Jul-13	5744.736	0	TDMA/TDD	2	20 %	Ni-MH	Right Ear	Ear/Tilt (15°)	113.3	0.0771	0.710
Jul-13	5825.952	94	TDMA/TDD	2	20 %	Ni-MH	Right Ear	Ear/Tilt (15°)	117.7	0.0543	1.20
Jul-13	5785.344	47	TDMA/TDD	2	20 %	Ni-MH	Left Ear	Cheek/Touch	116.3	0.162	1.17
Jul-16	5785.344	47	TDMA/TDD	2	20 %	Ni-MH	Left Ear	Ear/Tilt (15°)	116.3	0.0928	1.08
Jul-16	5744.736	0	TDMA/TDD	2	20 %	Ni-MH	Left Ear	Cheek/Touch	113.3	0.0965	0.980
Jul-16	5825.952	94	TDMA/TDD	2	20 %	Ni-MH	Left Ear	Cheek/Touch	117.7	-0.162	1.57
ANSI / IEEE C95.1: 2005 - SAFETY LIMIT				BRAIN: 1.6 W/kg (averaged over 1 gram)				Spatial Peak Uncontrolled Exposure / General Population			
Test Date(s)	July 13 & 16, 2007					Test Date	Jul-13	Jul-16	Unit		
Measured Fluid Type	5800 MHz Brain					Relative Humidity	35	31	%		
	IEEE Target	Date	Meas.	Dev.	Atmospheric Pressure	101.2	101.3	kPa			
Dielectric Constant ϵ_r	35.3	± 10%	Jul-13	33.1	-6.2%	Ambient Temperature	23.1	23.0	°C		
			Jul-16	31.9	-9.6%	Fluid Temperature	22.4	23.0	°C		
Conductivity σ (mho/m)	5.27	± 5%	Jul-13	5.42	+2.9%	Fluid Depth	≥ 15	≥ 15	cm		
			Jul-16	5.39	+2.3%	ρ (Kg/m³)	1000				
Notes	1.	The measurement results were obtained with the DUT tested in the conditions described in this report. Detailed measurement data and plots showing the maximum SAR location of the DUT are reported in Appendix A.									
	2.	The reference output power levels reported (field strength) were measured by Nemko Canada Inc.									
	3.	The power drift of the DUT measured by the DASY4 system during the SAR evaluation was < 5% from the start power.									
	4.	The DUT battery was fully charged prior to the SAR evaluations.									
	5.	The fluid temperature was measured prior to and after the SAR evaluations to ensure the temperature remained within +/-2°C of the fluid temperature reported during the dielectric parameter measurements.									
	6.	The dielectric parameters of the simulated tissue mixture were measured prior to the SAR evaluations using an ALS-PR-DIEL Dielectric Probe Kit and an HP 8753ET Network Analyzer (see Appendix C).									
	7.	The SAR evaluations were performed within 24 hours of the system performance checks.									

Company:	VTECH TELECOMMUNICATIONS LTD.	FCC ID:	EW780-6101-00	IC ID:	1135A-80610100	
Model(s):	LS5145 / LS5105	Portable 5.8 GHz Cordless Telephone Handset		Freq.:	5744 - 5825 MHz	
2007 Celltech Labs Inc.		This document is not to be reproduced in whole or in part without the prior written permission of Celltech Labs Inc.				Page 6 of 49

	<u>Date(s) of Evaluation</u> July 13 & 16, 2007	<u>Test Report Serial No.</u> 062107EW7-T839-S15T	<u>Report Revision No.</u> Revision 1.0	 Certificate No. 2470.01
	<u>Test Report Issue Date</u> July 20, 2007	<u>Description of Test(s)</u> Specific Absorption Rate	<u>RF Exposure Category</u> General Population	

5.0 DETAILS OF SAR EVALUATION

The VTECH TELECOMMUNICATIONS LTD. Model(s): LS5145 / LS5105 Portable 5.8 GHz Cordless Telephone Handset was compliant for localized Specific Absorption Rate (Uncontrolled Exposure) based on the test provisions and conditions described below. The detailed test setup photographs are shown in Appendix E.

Ear-held Configuration

- 1) The DUT was tested in an ear-held configuration on both the left and right sections of the SAM phantom at the mid channel of the operating band. If the SAR level at the mid channel of the frequency band for each test configuration (left ear, right ear, cheek/touch, ear/tilt) was ≥ 3 dB below the SAR limit, measurements at the low and high channels were optional (per FCC OET Bulletin 65, Supplement C, Edition 01-01 - see reference [3]).
 - a) The handset was placed in the device holder in a normal operating position with the test device reference point located along the vertical centerline on the front of the device aligned to the ear reference point, with the center of the earpiece touching the center of the ear spacer of the SAM phantom.
 - b) With the handset positioned parallel to the cheek, the test device reference point was aligned to the ear reference point on the head phantom, and the vertical centerline was aligned to the phantom reference plane (initial ear position).
 - c) While maintaining the three alignments, the body of the handset was gradually adjusted to each of the following test positions:
 - Cheek/Touch Position: the handset was brought toward the mouth of the head phantom by pivoting against the ear reference point until any point of the mouthpiece or keypad touched the phantom.

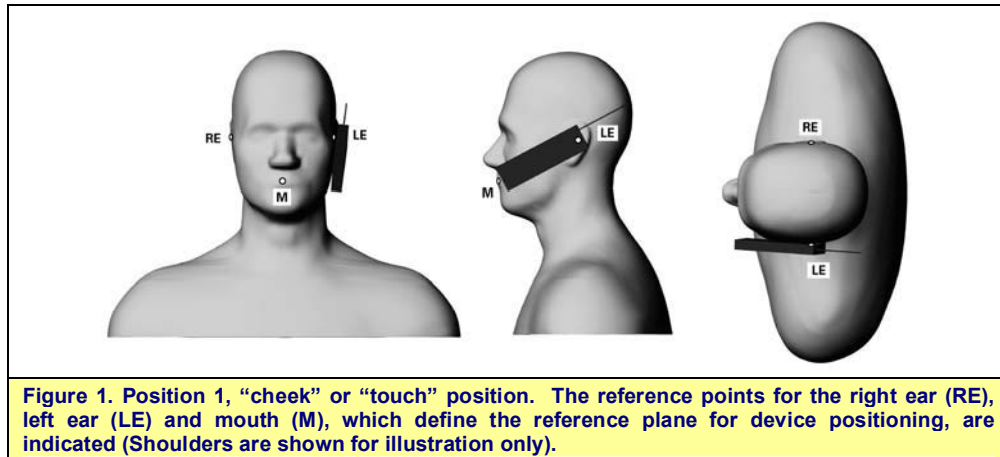

- Ear/Tilt Position: With the phone aligned in the Cheek/Touch position, the handset was tilted away from the mouth with respect to the test device reference point by 15 degrees.

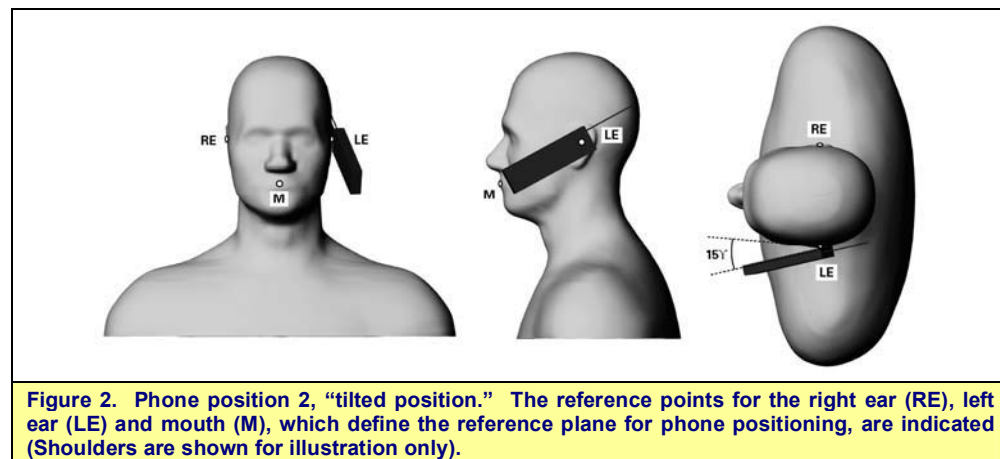

Company:	VTECH TELECOMMUNICATIONS LTD.	FCC ID:	EW780-6101-00	IC ID:	1135A-80610100	
Model(s):	LS5145 / LS5105	Portable 5.8 GHz Cordless Telephone Handset	Freq.:	5744 - 5825 MHz		
2007 Celltech Labs Inc.	This document is not to be reproduced in whole or in part without the prior written permission of Celltech Labs Inc.					Page 7 of 49

	<u>Date(s) of Evaluation</u> July 13 & 16, 2007	<u>Test Report Serial No.</u> 062107EW7-T839-S15T	<u>Report Revision No.</u> Revision 1.0	 Certificate No. 2470.01
	<u>Test Report Issue Date</u> July 20, 2007	<u>Description of Test(s)</u> Specific Absorption Rate	<u>RF Exposure Category</u> General Population	

DETAILS OF SAR EVALUATION (Cont.)

Body-worn Configuration

- 2) The DUT does not have an audio connector and does not support body-worn transmit operation.

Test Mode(s) & Power Setting(s)

- 3) The DUT was placed in test mode using the customer's proprietary internal test software programmed via the keypad.
- 4) The SAR evaluations were performed with the DUT transmitting on a fixed frequency at maximum power in TDMA/TDD modulation at the maximum source-based time-averaged duty cycle (20%) in 2 uplink slots with a crest factor of 1:5.
- 5) The conducted power level(s) of the DUT could not be measured for the SAR evaluation due to internal antenna. The DUT was evaluated for SAR at the maximum conducted power level preset by the manufacturer. The RF output power reference levels reported (field strength levels) were measured by Nemko Canada on the same unit.
- 6) The power drift of the DUT was measured by the DASY4 system for the duration the SAR evaluations.
- 7) The DUT battery was fully charged prior to the SAR evaluations.

Ambient Conditions

- 8) The fluid temperature was measured prior to and after the SAR evaluations to ensure the temperature remained within +/-2°C of the fluid temperature reported during the dielectric parameter measurements.
- 9) The dielectric parameters of the simulated tissue mixture were measured prior to the SAR evaluations using an ALS-PR-DIEL Dielectric Probe Kit and an HP 8753ET Network Analyzer (see Appendix C).
- 10) The SAR evaluations were performed within 24 hours of the system performance checks.

6.0 EVALUATION PROCEDURES

- a. (i) The evaluation was performed in the applicable area of the phantom depending on the type of device being tested. For devices held to the ear during normal operation, both the left and right ear positions were evaluated using the SAM phantom.
- (ii) For body-worn and face-held devices a planar phantom was used.
- b. The SAR was determined by a pre-defined procedure within the DASY4 software. Upon completion of a reference and optical surface check, the exposed region of the phantom was scanned near the inner surface with a grid spacing of 15mm x 15mm.

An area scan was determined as follows:

- c. Based on the defined area scan grid, a more detailed grid is created to increase the points by a factor of 10. The interpolation function then evaluates all field values between corresponding measurement points.
- d. A linear search is applied to find all the candidate maxima. Subsequently, all maxima are removed that are >2 dB from the global maximum. The remaining maxima are then used to position the cube scans.

A 1g and 10g spatial peak SAR was determined as follows:

- e. Extrapolation is used to determine the values between the dipole center of the probe and the surface of the phantom. This data cannot be measured because the center of the dipole sensors is 1.0 mm away from the probe tip and the distance between the probe and the boundary must be larger than 25% of the probe diameter. The probe diameter is 2.4 mm. In the DASY4 software, the distance between the sensor center and phantom surface is set to 2.0 mm. This provides a distance of 1.0 mm between the probe tip and the surface. The extrapolation of the values between the dipole center and the surface of the phantom was based on trivariate quadratics computed from the previously calculated 3D interpolated points nearest the phantom surface.
- f. Interpolated data is used to calculate the average SAR over 1g and 10g cubes by spatially discretizing the entire measured cube. The volume used to determine the averaged SAR is a 1 mm grid (42875 interpolated points).
- g. A zoom scan volume of 24 mm x 24 mm x 20 mm (7x7x9 points) centered at the peak SAR location determined from the area scan was used and a zoom scan resolution of 4 mm x 4 mm x 2.5 mm was used.
- h. The procedures described in FCC document "SAR Measurement Requirements for 3 - 6 GHz" (see reference [7]) were applied.

Company:	VTECH TELECOMMUNICATIONS LTD.	FCC ID:	EW780-6101-00	IC ID:	1135A-80610100	
Model(s):	LS5145 / LS5105	Portable 5.8 GHz Cordless Telephone Handset		Freq.:	5744 - 5825 MHz	
2007 Celltech Labs Inc.		This document is not to be reproduced in whole or in part without the prior written permission of Celltech Labs Inc.				Page 8 of 49

EVALUATION PROCEDURES (Cont.)

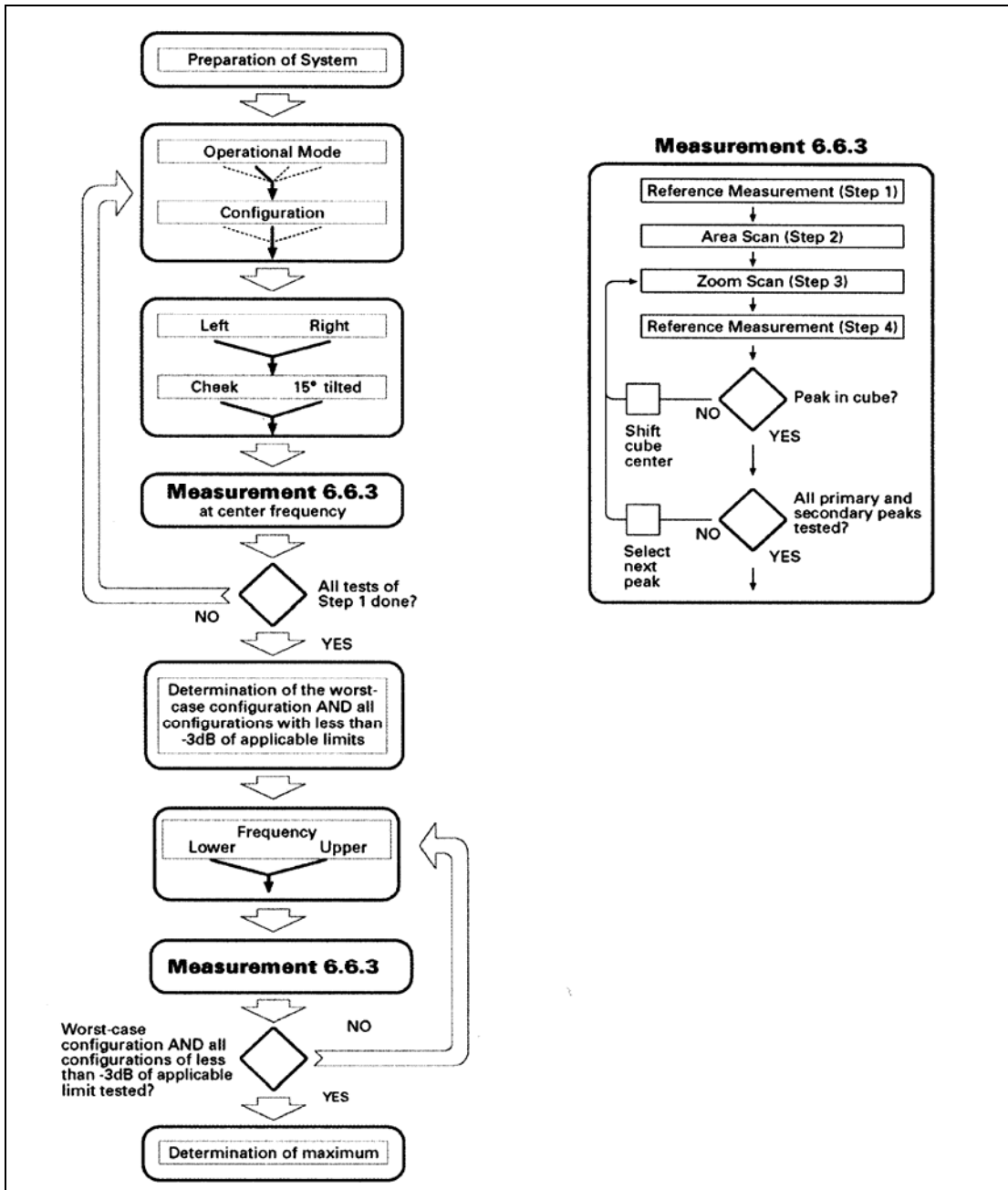

Figure 3. Flow Chart for determining the largest peak spatial-average SAR from all device configurations per IEEE Standard 1528-2003 (see reference [5]).

7.0 SYSTEM PERFORMANCE CHECK

Prior to the SAR evaluations, system checks were performed at the planar section of the SAM phantom with a SPEAG D5GHzV2 validation dipole (see Appendix F for system validation procedures). The dielectric parameters of the simulated tissue mixture were measured prior to the system performance check using an ALS-PR-DIEL Dielectric Probe Kit and an HP 8753ET Network Analyzer (see Appendix C). A forward power of 250 mW was applied to the dipole and the system was verified to a tolerance of $\pm 10\%$ (see Appendix B for system performance check test plots). See Figure 5 below for the SAR system manufacturer's reference head SAR values (5 GHz) from the DASY4 Manual (see reference [8]).

SYSTEM PERFORMANCE CHECK EVALUATIONS																	
Test Date	Equiv. Tissue (MHz)	SAR 1g (W/kg)			PEAK SAR (W/kg)			Dielectric Constant ϵ_r			Conductivity σ (mho/m)			Amb. Temp. (°C)	Fluid Temp. (°C)	Humid %	Barom. Press. (kPa)
		SPEAG Target	Meas.	Dev.	SPEAG Target	Meas.	Dev.	IEEE Target	Meas.	Dev.	IEEE Target	Meas.	Dev.				
Jul-13	5800 Brain	19.5 $\pm 10\%$	20.5	+5.2%	85.2 $\pm 15\%$	91.6	+7.5%	35.3 $\pm 10\%$	33.1	-6.2%	5.27 $\pm 5\%$	5.42	+2.9%	23.1	22.4	35	101.2
Jul-16	5800 Brain	19.5 $\pm 10\%$	19.5	0.0%	85.2 $\pm 15\%$	89.1	+4.6%	35.3 $\pm 10\%$	31.9	-9.6%	5.27 $\pm 5\%$	5.39	+2.3%	23.0	23.0	31	101.3
Fluid Depth		≥ 15 cm		Note(s)	1. The fluid temperature was measured prior to and after the system performance checks to ensure the temperature remained within $\pm 2^\circ\text{C}$ of the fluid temperature reported during the dielectric parameter measurements.												
ρ (Kg/m³)		1000			2. The SAR evaluations were performed within 24 hours of the system performance checks.												

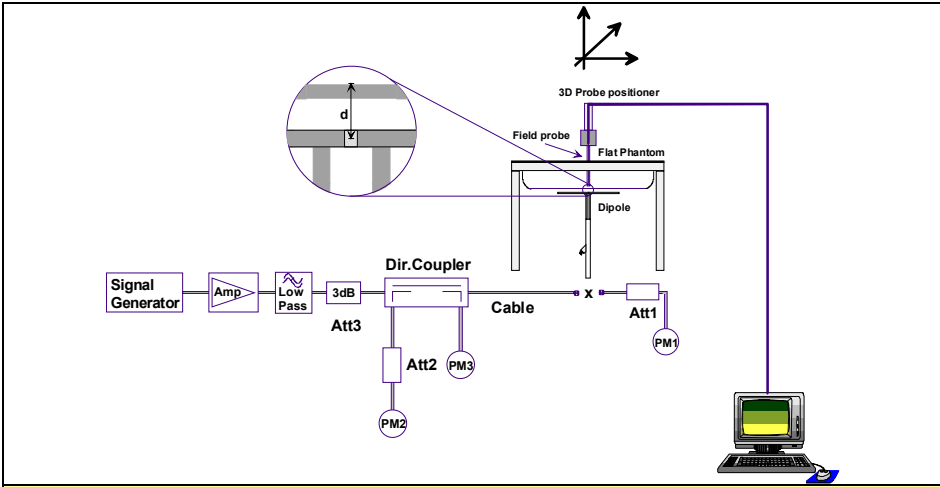
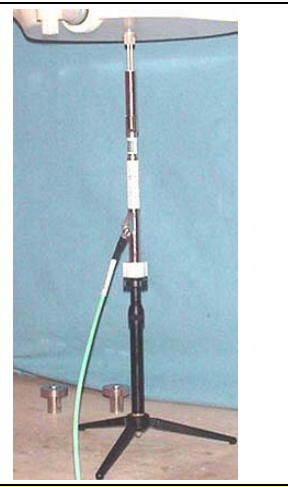

Figure 4. System Performance Check Measurement Setup



5 GHz Dipole Setup

Reference SAR values

The reference SAR values were calculated using finite-difference time-domain FDTD method (feed-point impedance set to 50 Ω) and the mechanical dimensions of the D5GHzV2 dipole (manufactured by SPEAG).

f (GHz)	Head Tissue			Body Tissue		
	SAR _{1g}	SAR _{10g}	SAR _{peak}	SAR _{1g}	SAR _{10g}	SAR _{peak}
5.0	72.9	20.7	285.6	68.1	19.2	260.3
5.1	74.6	21.1	297.5	78.8	19.6	272.3
5.2	76.5	21.6	310.3	71.8	20.1	284.7
5.5	83.3	23.4	349.4	79.1	22.0	326.3
5.8	78.0	21.9	340.9	74.1	20.5	324.7

Table 27.2: Numerical reference SAR values for D5GHzV2 dipole and flat phantom.

Figure 5. System Manufacturer's Reference Head SAR Values (5 GHz)



5 GHz Dipole

8.0 SIMULATED EQUIVALENT TISSUES

The 5.8 GHz simulated tissue mixtures were provided by the SAR system manufacturer (SPEAG) and are listed below. The dielectric parameters of the tissue mixture (permittivity and conductivity) were measured prior to the SAR evaluations. See Appendix D for manufacturer's fluid data sheet.

SIMULATED TISSUE MIXTURES							
INGREDIENT		5.8 GHz Brain			5.8 GHz Body		
Water		64 - 78%			64 - 78%		
Mineral Oil		11 - 18%			11 - 18%		
Emulsifiers		9 - 15%			9 - 15%		
Additives and Salt		2 - 3%			2 - 3%		
TISSUE TEMPERATURE SENSITIVITY							
Tissue Type	Temp. (°C)	Dielectric Constant ϵ_r			Conductivity σ (mho/m)		
		IEEE Target	Measured	Deviation	IEEE Target	Measured	Deviation
5.8 GHz Brain	20	35.3 \pm 10%	34.2	-3.0 %	5.27 \pm 5%	5.13	-2.6 %
5.8 GHz Brain	22		35.1	-0.5 %		5.16	-2.0 %
5.8 GHz Brain	24		34.9	-1.0 %		5.06	-4.0 %
Note(s)	1. The fluid temperature sensitivity data reported above is a reference example of the 5.8 GHz Brain tissue dielectric parameter deviation when subjected to +/- 2°C. The data shows that the dielectric parameters remain within the required tolerance from the target value.						

9.0 SAR SAFETY LIMITS

EXPOSURE LIMITS	SAR (W/kg)	
	(General Population / Uncontrolled Exposure Environment)	(Occupational / Controlled Exposure Environment)
Spatial Average (averaged over the whole body)	0.08	0.4
Spatial Peak (averaged over any 1 g of tissue)	1.60	8.0
Spatial Peak (hands/wrists/feet/ankles averaged over 10 g)	4.0	20.0
The Spatial Average value of the SAR averaged over the whole body.		
The Spatial Peak value of the SAR averaged over any 1 gram of tissue (defined as a tissue volume in the shape of a cube) and over the appropriate averaging time.		
The Spatial Peak value of the SAR averaged over any 10 grams of tissue (defined as a tissue volume in the shape of a cube) and over the appropriate averaging time.		
Uncontrolled environments are defined as locations where there is potential exposure of individuals who have no knowledge or control of their potential exposure.		
Controlled environments are defined as locations where there is potential exposure of individuals who have knowledge of their potential exposure and can exercise control over their exposure.		

10.0 ROBOT SYSTEM SPECIFICATIONS

<u>Specifications</u>	
Positioner	Stäubli Unimation Corp. Robot Model: RX60L
Repeatability	0.02 mm
No. of axis	6
<u>Data Acquisition Electronic (DAE) System</u>	
<u>Cell Controller</u>	
Processor	AMD Athlon XP 2400+
Clock Speed	2.0 GHz
Operating System	Windows XP Professional
<u>Data Converter</u>	
Features	Signal Amplifier, multiplexer, A/D converter, and control logic
Software	Measurement Software: DASYS4, V4.7 Build 44
	Postprocessing Software: SEMCAD, V1.8 Build 171
Connecting Lines	Optical downlink for data and status info.; Optical uplink for commands and clock
<u>DASY4 Measurement Server</u>	
Function	Real-time data evaluation for field measurements and surface detection
Hardware	PC/104 166MHz Pentium CPU; 32 MB chipdisk; 64 MB RAM
Connections	COM1, COM2, DAE, Robot, Ethernet, Service Interface
<u>E-Field Probe</u>	
Model	EX3DV4
Serial No.	3600
Construction	Symmetrical design with triangular core
Frequency	10 MHz to 6 GHz
Linearity	±0.2 dB (30 MHz to 3 GHz)
<u>Phantom(s)</u>	
Type	SAM V4.0C
Shell Material	Fiberglass
Thickness	2.0 ±0.1 mm
Volume	Approx. 25 liters

	<u>Date(s) of Evaluation</u> July 13 & 16, 2007	<u>Test Report Serial No.</u> 062107EW7-T839-S15T	<u>Report Revision No.</u> Revision 1.0	 
	<u>Test Report Issue Date</u> July 20, 2007	<u>Description of Test(s)</u> Specific Absorption Rate	<u>RF Exposure Category</u> General Population	

11.0 PROBE SPECIFICATION (EX3DV4)

<p>Construction: Symmetrical design with triangular core Built-in shielding against static charges PEEK enclosure material (resistant to organic solvents, e.g. DGBE)</p> <p>Calibration: Basic Broadband Calibration in air: 10-3000 MHz Conversion Factors (CF) for HSL 900 and HSL 1750</p> <p>Frequency: 10 MHz to >6 GHz; Linearity: ± 0.2 dB (30 MHz to 3 GHz)</p> <p>Directivity: ± 0.3 dB in HSL (rotation around probe axis) ± 0.5 dB in tissue material (rotation normal to probe axis)</p> <p>Dynamic Range: 10 μW/g to >100 mW/g; Linearity: ± 0.2 dB (noise: typically < 1 μW/g)</p> <p>Dimensions: Overall length: 330 mm (Tip: 20 mm) Tip diameter: 2.5 mm (Body: 12 mm) Typical distance from probe tip to dipole centers: 1.0 mm</p> <p>Application: High precision dosimetric measurements in any exposure scenario (e.g., very strong gradient fields). Only probe which enables compliance testing for frequencies up to 6 GHz with precision of better than 30%.</p>	
EX3DV4 E-Field Probe	

12.0 SAM PHANTOM V4.0C

<p>The SAM phantom V4.0C is a fiberglass shell phantom with a 2.0 mm (+/-0.2 mm) shell thickness for left and right head and flat planar area integrated in a wooden table. The shape of the fiberglass shell corresponds to the phantom defined by SCC34-SC2. The device holder positions are adjusted to the standard measurement positions in the three sections (see Appendix H for specifications of the SAM phantom V4.0C).</p>	
SAM Phantom V4.0C	

13.0 DEVICE HOLDER

<p>The DASY4 device holder has two scales for device rotation (with respect to the body axis) and the device inclination (with respect to the line between the ear openings). The plane between the ear openings and the mouth tip has a rotation angle of 65°. The bottom plate contains three pair of bolts for locking the device holder. The device holder positions are adjusted to the standard measurement positions in the three sections.</p>	
Device Holder	

Company: VTECH TELECOMMUNICATIONS LTD.	FCC ID: EW780-6101-00	IC ID: 1135A-80610100	
Model(s): LS5145 / LS5105	Portable 5.8 GHz Cordless Telephone Handset	Freq.: 5744 - 5825 MHz	
2007 Celltech Labs Inc.	This document is not to be reproduced in whole or in part without the prior written permission of Celltech Labs Inc.		Page 13 of 49

14.0 TEST EQUIPMENT LIST

TEST EQUIPMENT		ASSET NO.	SERIAL NO.	DATE CALIBRATED		CALIBRATION DUE DATE
USED	DESCRIPTION			Brain	Body	
x	Schmid & Partner DASY4 System	-	-	-	-	-
x	-DASY4 Measurement Server	00158	1078	N/A	N/A	N/A
x	-Robot	00046	599396-01	N/A	N/A	N/A
	-DAE4	00019	353	10Jul07	10Jul08	10Jul08
x	-DAE3	00018	370	13Mar07	13Mar08	13Mar08
	-ET3DV6 E-Field Probe	00016	1387	16Mar07	16Mar08	16Mar08
x	-EX3DV4 E-Field Probe	00213	3600	24Jan07	24Jan08	24Jan08
	-300 MHz Validation Dipole	00023	135	08Jun07	08Jun08	08Jun08
	-450 MHz Validation Dipole	00024	136	07Jun07	07Jun08	07Jun08
	-835 MHz Validation Dipole	00022	411	Brain	07Jun07	07Jun08
				Body	07Jun07	07Jun08
	-900 MHz Validation Dipole	00020	054	Brain	07Jun07	07Jun08
				Body	07Jun07	07Jun08
	-1800 MHz Validation Dipole	00021	247	Brain	06Jun07	06Jun08
				Body	06Jun07	06Jun08
	-1900 MHz Validation Dipole	00032	151	Brain	06Jun07	06Jun08
				Body	06Jun07	06Jun08
	-2450 MHz Validation Dipole	00025	150	Brain	08Jun07	08Jun08
				Body	08Jun07	08Jun08
	5GHz Validation Dipole	00126	1031	Body	18May07	18May08
				Body	22May07	22May08
x				Brain	09May07	09May08
				Body	10May07	10May08
x	-SAM Phantom V4.0C	00154	1033	N/A	N/A	N/A
	-Barski Planar Phantom	00155	03-01	N/A	N/A	N/A
	-Plexiglas Side Planar Phantom	00156	161	N/A	N/A	N/A
	-Plexiglas Validation Planar Phantom	00157	137	N/A	N/A	N/A
x	ALS-PR-DIEL Dielectric Probe Kit	00160	260-00953	N/A	N/A	N/A
x	Gigatronics 8652A Power Meter	00007	1835272	26Mar07	26Mar08	26Mar08
	Gigatronics 8652A Power Meter	00008	1835267	22Jan07	22Jan08	22Jan08
	Gigatronics 80701A Power Sensor	00012	1834350	22Jan07	22Jan08	22Jan08
x	Gigatronics 80701A Power Sensor	00014	1833699	22Jan07	22Jan08	22Jan08
x	Gigatronics 80701A Power Sensor	00109	1834366	26Mar07	26Mar08	26Mar08
x	HP 8753ET Network Analyzer	00134	US39170292	20Apr07	20Apr08	20Apr08
	HP 8648D Signal Generator	00005	3847A00611	NCR	NCR	NCR
x	Rohde & Schwarz SMR20 Signal Generator	00006	100104	NCR	NCR	NCR
	Amplifier Research 5S1G4 Power Amplifier	00106	26235	NCR	NCR	NCR
	Amplifier Research 10W 1000C Power Amplifier	00041	27887	NCR	NCR	NCR
x	Nextec NB00383 Microwave Amplifier	00151	0535	NCR	NCR	NCR
	HP E4408B Spectrum Analyzer	00015	US39240170	05Feb07	05Feb08	05Feb08

15.0 MEASUREMENT UNCERTAINTIES

UNCERTAINTY BUDGET FOR DEVICE EVALUATION						
Error Description	Uncertainty Value ±%	Probability Distribution	Divisor	ci 1g	Uncertainty Value ±% (1g)	V _i or V _{eff}
Measurement System						
Probe calibration (5 GHz)	6.6	Normal	1	1	6.6	∞
Axial isotropy of the probe	4.7	Rectangular	1.732050808	0.7	1.9	∞
Spherical isotropy of the probe	9.6	Rectangular	1.732050808	0.7	3.9	∞
Spatial resolution	0	Rectangular	1.732050808	1	0.0	∞
Boundary effects	2	Rectangular	1.732050808	1	1.2	∞
Probe linearity	4.7	Rectangular	1.732050808	1	2.7	∞
Detection limit	1	Rectangular	1.732050808	1	0.6	∞
Readout electronics	0.3	Normal	1	1	0.3	∞
Response time	0.8	Rectangular	1.732050808	1	0.5	∞
Integration time	2.6	Rectangular	1.732050808	1	1.5	∞
RF ambient conditions	3	Rectangular	1.732050808	1	1.7	∞
Mech. constraints of robot	0.8	Rectangular	1.732050808	1	0.5	∞
Probe positioning	5.7	Rectangular	1.732050808	1	3.3	∞
Extrapolation & integration	4	Rectangular	1.732050808	1	2.3	∞
Test Sample Related						
Device positioning	2.9	Normal	1	1	2.9	12
Device holder uncertainty	3.6	Normal	1	1	3.6	8
Power drift	5	Rectangular	1.732050808	1	2.9	∞
Phantom and Setup						
Phantom uncertainty	4	Rectangular	1.732050808	1	2.3	∞
Liquid conductivity (target)	5	Rectangular	1.732050808	0.64	1.8	∞
Liquid conductivity (measured)	5	Normal	1	0.64	3.2	∞
Liquid permittivity (target)	10	Rectangular	1.732050808	0.6	3.5	∞
Liquid permittivity (measured)	5	Normal	1	0.6	3.0	∞
Combined Standard Uncertainty					12.74	
Expanded Uncertainty (k=2)					25.47	
Measurement Uncertainty Table in accordance with IEEE Standard 1528-2003 (see reference [5])						

MEASUREMENT UNCERTAINTIES (Cont.)

UNCERTAINTY BUDGET FOR SYSTEM VALIDATION						
Error Description	Uncertainty Value ±%	Probability Distribution	Divisor	ci 1g	Uncertainty Value ±% (1g)	V _i or V _{eff}
Measurement System						
Probe calibration (5 GHz)	6.6	Normal	1	1	6.6	∞
Axial isotropy of the probe	4.7	Rectangular	1.732050808	1	2.7	∞
Spherical isotropy of the probe	9.6	Rectangular	1.732050808	1	5.5	∞
Spatial resolution	0	Rectangular	1.732050808	1	0.0	∞
Boundary effects	2	Rectangular	1.732050808	1	1.2	∞
Probe linearity	4.7	Rectangular	1.732050808	1	2.7	∞
Detection limit	1	Rectangular	1.732050808	1	0.6	∞
Readout electronics	0.3	Normal	1	1	0.3	∞
Response time	0	Rectangular	1.732050808	1	0.0	∞
Integration time	0	Rectangular	1.732050808	1	0.0	∞
RF ambient conditions	3	Rectangular	1.732050808	1	1.7	∞
Mech. constraints of robot	0.8	Rectangular	1.732050808	1	0.5	∞
Probe positioning	5.7	Rectangular	1.732050808	1	3.3	∞
Extrapolation & integration	4	Rectangular	1.732050808	1	2.3	∞
Dipole						
Dipole positioning	2	Rectangular	1.732050808	1	1.2	∞
Power & Power Drift	4.7	Rectangular	1.732050808	1	2.7	∞
Phantom and Setup						
Phantom uncertainty	4	Rectangular	1.732050808	1	2.3	∞
Liquid conductivity (target)	5	Rectangular	1.732050808	0.64	1.8	∞
Liquid conductivity (measured)	5	Normal	1	0.64	3.2	∞
Liquid permittivity (target)	10	Rectangular	1.732050808	0.6	3.5	∞
Liquid permittivity (measured)	5	Normal	1	0.6	3.0	∞
Combined Standard Uncertainty					12.58	
Expanded Uncertainty (k=2)					25.15	
Measurement Uncertainty Table in accordance with IEEE Standard 1528-2003 (see reference [5])						

	<u>Date(s) of Evaluation</u> July 13 & 16, 2007	<u>Test Report Serial No.</u> 062107EW7-T839-S15T	<u>Report Revision No.</u> Revision 1.0	 Certificate No. 2470.01
	<u>Test Report Issue Date</u> July 20, 2007	<u>Description of Test(s)</u> Specific Absorption Rate	<u>RF Exposure Category</u> General Population	

16.0 REFERENCES

- [1] Federal Communications Commission - "Radiofrequency radiation exposure evaluation: portable devices", Rule Part 47 CFR §2.1093: 1999.
- [2] Health Canada - "Limits of Human Exposure to Radiofrequency Electromagnetic Fields in the Frequency Range from 3 kHz to 300 GHz", Safety Code 6:1999.
- [3] Federal Communications Commission - "Evaluating Compliance with FCC Guidelines for Human Exposure to Radio frequency Electromagnetic Fields", OET Bulletin 65, Supplement C (Edition 01-01), FCC, Washington, D.C.: June 2001.
- [4] Industry Canada - "Radio Frequency Exposure Compliance of Radiocommunication Apparatus (All Frequency Bands)", Radio Standards Specification RSS-102 Issue 2: November 2005.
- [5] IEEE Standard 1528-2003 - "Recommended Practice for Determining the Peak Spatial-Average Specific Absorption Rate (SAR) in the Human Head from Wireless Communications Devices: Measurement Techniques": December 2003.
- [6] ANSI/IEEE C95.1-2005 - "American National Standard safety levels with respect to human exposure to radio frequency electromagnetic fields, 3 kHz to 300 GHz", New York: IEEE, April 2006.
- [7] Federal Communications Commission - "SAR Measurement Requirements for 3 - 6 GHz": October 2006 (Rev. 1.1).
- [8] Schmid & Partner Engineering AG - "DASY4 Manual", V4.5: March 2005.

Company:	VTECH TELECOMMUNICATIONS LTD.	FCC ID:	EW780-6101-00	IC ID:	1135A-80610100	
Model(s):	LS5145 / LS5105	Portable 5.8 GHz Cordless Telephone Handset		Freq.:	5744 - 5825 MHz	
2007 Celltech Labs Inc.		This document is not to be reproduced in whole or in part without the prior written permission of Celltech Labs Inc.				Page 17 of 49

	<u>Date(s) of Evaluation</u> July 13 & 16, 2007	<u>Test Report Serial No.</u> 062107EW7-T839-S15T	<u>Report Revision No.</u> Revision 1.0	 Certificate No. 2470.01
	<u>Test Report Issue Date</u> July 20, 2007	<u>Description of Test(s)</u> Specific Absorption Rate	<u>RF Exposure Category</u> General Population	

APPENDIX A - SAR MEASUREMENT DATA

Company:	VTECH TELECOMMUNICATIONS LTD.	FCC ID:	EW780-6101-00	IC ID:	1135A-80610100	
Model(s):	LS5145 / LS5105	Portable 5.8 GHz Cordless Telephone Handset		Freq.:	5744 - 5825 MHz	
2007 Celltech Labs Inc.		This document is not to be reproduced in whole or in part without the prior written permission of Celltech Labs Inc.				Page 18 of 49

	<u>Date(s) of Evaluation</u> July 13 & 16, 2007	<u>Test Report Serial No.</u> 062107EW7-T839-S15T	<u>Report Revision No.</u> Revision 1.0	 Certificate No. 2470.01
	<u>Test Report Issue Date</u> July 20, 2007	<u>Description of Test(s)</u> Specific Absorption Rate	<u>RF Exposure Category</u> General Population	

Date Tested: 07/13/2007

Head SAR - Right Ear - Cheek/Touch Position - 5785.344 MHz - Channel 47

DUT: Vtech Model: LS5145; Type: Portable 5.8GHz Cordless Telephone Handset; Serial: 2

Ambient Temp: 23.1°C; Fluid Temp: 22.4°C; Barometric Pressure: 101.2 kPa; Humidity: 35%

Power: 3.6V, 550mAh NiMH Battery
 Communication System: TDD/TDMA
 Frequency: 5785.344 MHz; Duty Cycle: 1:5
 RF Output Power: 116.3 dBuV/m (Field Strength)
 Medium: HSL5200-5800 Medium parameters used: $f = 5785.34 \text{ MHz}$; $\sigma = 5.42 \text{ mho/m}$; $\epsilon_r = 33.1$; $\rho = 1000 \text{ kg/m}^3$

- Probe: EX3DV4 - SN3600; ConvF(4.34, 4.34, 4.34); Calibrated: 24/01/2007
- Sensor-Surface: 2 mm (Mechanical Surface Detection)
- Electronics: DAE3 Sn370; Calibrated: 13/03/2007
- Phantom: SAM 4.0; Type: Fiberglass; Serial: 1033
- Measurement SW: DASY4, V4.7 Build 44; Postprocessing SW: SEMCAD, V1.8 Build 171

Head SAR - Right Ear - Cheek/Touch Position - Mid Channel/Area Scan (9x15x1):

Measurement grid: $dx=10\text{mm}$, $dy=10\text{mm}$
 Maximum value of SAR (measured) = 1.87 mW/g

Head SAR - Right Ear - Cheek/Touch Position - Mid Channel/Zoom Scan (7x7x9)/Cube 0:

Measurement grid: $dx=4\text{mm}$, $dy=4\text{mm}$, $dz=2.5\text{mm}$
 Reference Value = 13.8 V/m; Power Drift = -0.0713 dB
 Peak SAR (extrapolated) = 4.02 W/kg
SAR(1 g) = 1.02 mW/g; SAR(10 g) = 0.380 mW/g
 Maximum value of SAR (measured) = 1.93 mW/g

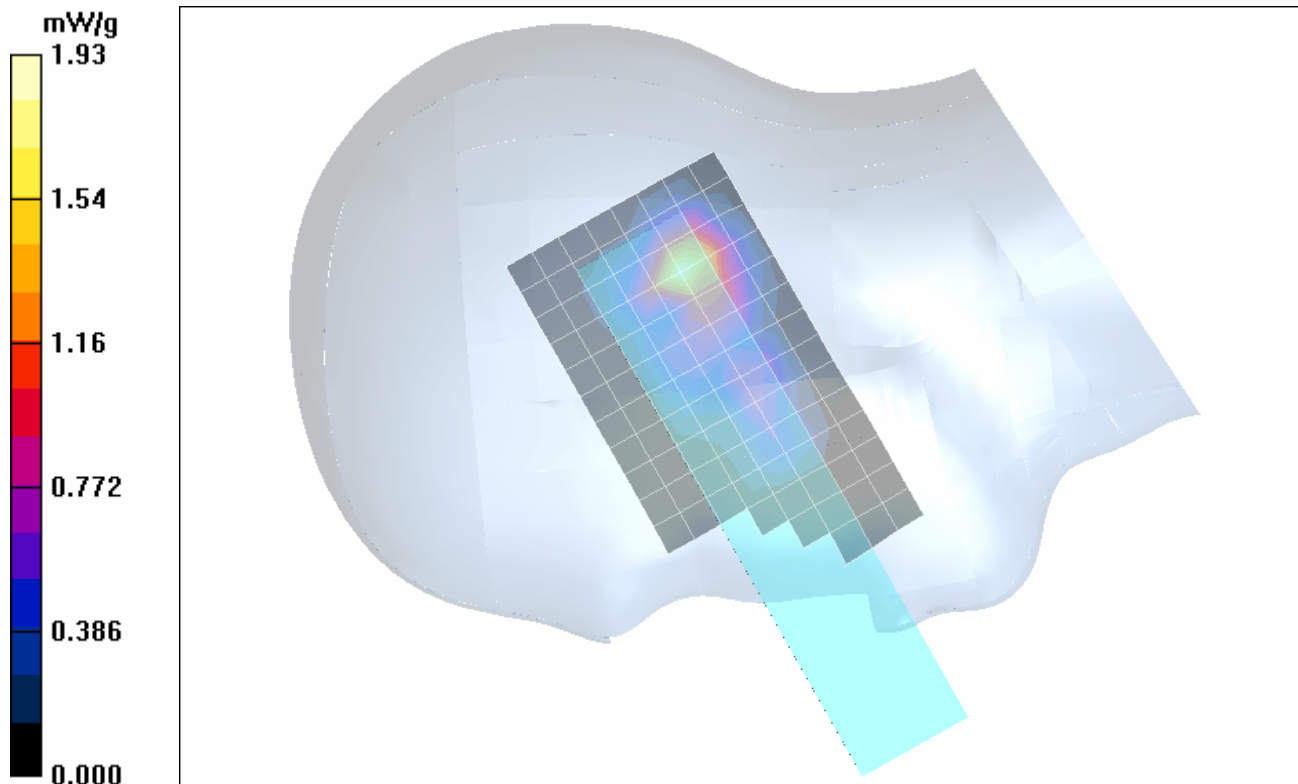

Company:	VTECH TELECOMMUNICATIONS LTD.	FCC ID:	EW780-6101-00	IC ID:	1135A-80610100	
Model(s):	LS5145 / LS5105	Portable 5.8 GHz Cordless Telephone Handset		Freq.:	5744 - 5825 MHz	
2007 Celltech Labs Inc.		This document is not to be reproduced in whole or in part without the prior written permission of Celltech Labs Inc.				Page 19 of 49

	<u>Date(s) of Evaluation</u> July 13 & 16, 2007	<u>Test Report Serial No.</u> 062107EW7-T839-S15T	<u>Report Revision No.</u> Revision 1.0	 Certificate No. 2470.01
	<u>Test Report Issue Date</u> July 20, 2007	<u>Description of Test(s)</u> Specific Absorption Rate	<u>RF Exposure Category</u> General Population	

Date Tested: 07/13/2007

Head SAR - Right Ear - Tilt Position (15°) - 5785.344 MHz - Channel 47

DUT: Vtech Model: LS5145; Type: Portable 5.8GHz Cordless Telephone Handset; Serial: 2

Ambient Temp: 23.1°C; Fluid Temp: 22.4°C; Barometric Pressure: 101.2 kPa; Humidity: 35%

Power: 3.6V, 550mAh NiMH Battery
 Communication System: TDD/TDMA
 Frequency: 5785.344 MHz; Duty Cycle: 1:5
 RF Output Power: 116.3 dBuV/m (Field Strength)
 Medium: HSL5200-5800 Medium parameters used: $f = 5785.34 \text{ MHz}$; $\sigma = 5.42 \text{ mho/m}$; $\epsilon_r = 33.1$; $\rho = 1000 \text{ kg/m}^3$

- Probe: EX3DV4 - SN3600; ConvF(4.34, 4.34, 4.34); Calibrated: 24/01/2007
- Sensor-Surface: 2 mm (Mechanical Surface Detection)
- Electronics: DAE3 Sn370; Calibrated: 13/03/2007
- Phantom: SAM 4.0; Type: Fiberglass; Serial: 1033
- Measurement SW: DASY4, V4.7 Build 44; Postprocessing SW: SEMCAD, V1.8 Build 171

Head SAR - Right Ear - Tilt Position (15°) - Mid Channel/Area Scan (9x15x1):

Measurement grid: $dx=10\text{mm}$, $dy=10\text{mm}$
 Maximum value of SAR (measured) = 2.00 mW/g

Head SAR - Right Ear - Tilt Position (15°) - Mid Channel/Zoom Scan (7x7x9)/Cube 0:

Measurement grid: $dx=4\text{mm}$, $dy=4\text{mm}$, $dz=2.5\text{mm}$
 Reference Value = 14.2 V/m; Power Drift = -0.0386 dB
 Peak SAR (extrapolated) = 4.14 W/kg
SAR(1 g) = 1.06 mW/g; SAR(10 g) = 0.381 mW/g
 Maximum value of SAR (measured) = 2.03 mW/g

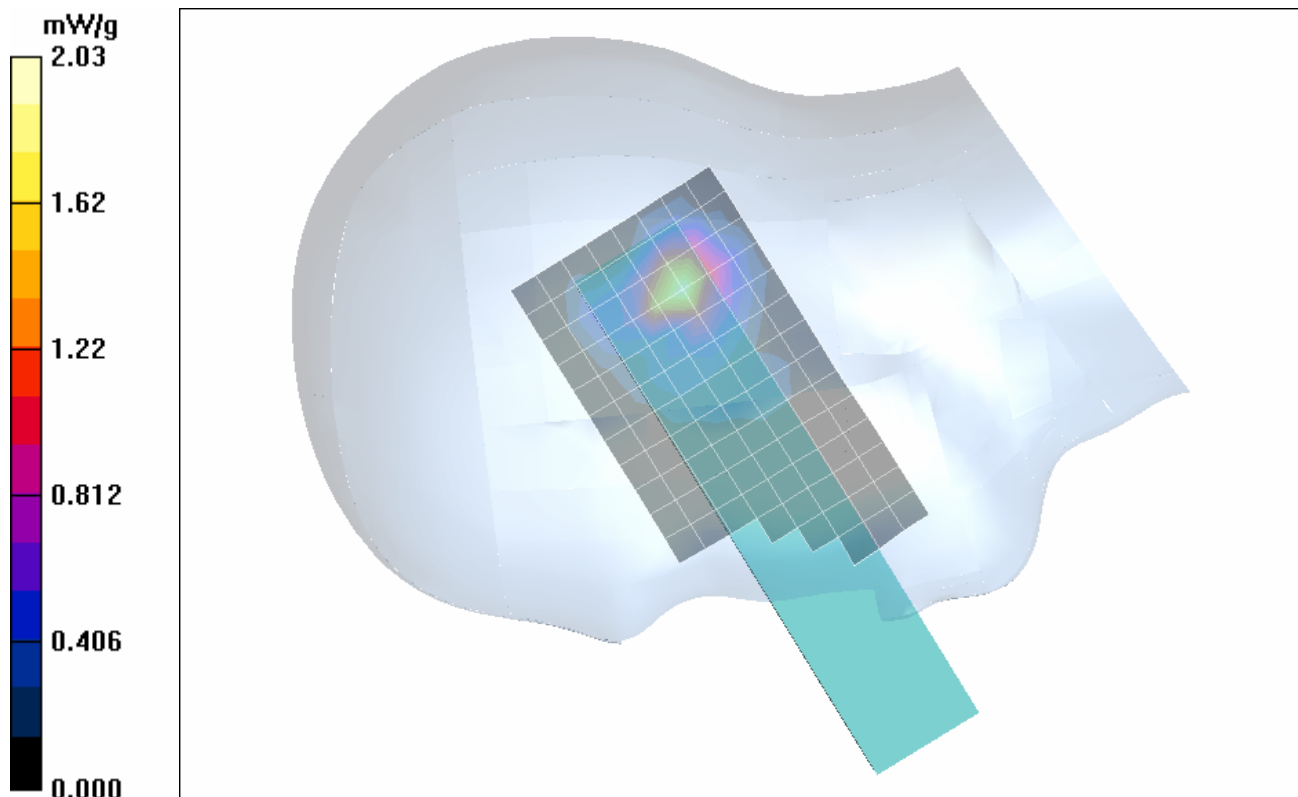

Company:	VTECH TELECOMMUNICATIONS LTD.	FCC ID:	EW780-6101-00	IC ID:	1135A-80610100	
Model(s):	LS5145 / LS5105	Portable 5.8 GHz Cordless Telephone Handset		Freq.:	5744 - 5825 MHz	
2007 Celltech Labs Inc.		This document is not to be reproduced in whole or in part without the prior written permission of Celltech Labs Inc.				Page 20 of 49

	<u>Date(s) of Evaluation</u> July 13 & 16, 2007	<u>Test Report Serial No.</u> 062107EW7-T839-S15T	<u>Report Revision No.</u> Revision 1.0	
	<u>Test Report Issue Date</u> July 20, 2007	<u>Description of Test(s)</u> Specific Absorption Rate	<u>RF Exposure Category</u> General Population	

Date Tested: 07/13/2007

Head SAR - Right Ear - Tilt Position (15°) - 5744.736 MHz - Channel 0

DUT: Vtech Model: LS5145; Type: Portable 5.8GHz Cordless Telephone Handset; Serial: 2

Ambient Temp: 23.1°C; Fluid Temp: 22.4°C; Barometric Pressure: 101.2 kPa; Humidity: 35%

Power: 3.6V, 550mAh NiMH Battery
 Communication System: TDD/TDMA
 Frequency: 5744.736 MHz; Duty Cycle: 1:5
 RF Output Power: 113.3 dBuV/m (Field Strength)
 Medium: HSL5200-5800 Medium parameters used: $f = 5744.74 \text{ MHz}$; $\sigma = 5.42 \text{ mho/m}$; $\epsilon_r = 33.1$; $\rho = 1000 \text{ kg/m}^3$

- Probe: EX3DV4 - SN3600; ConvF(4.34, 4.34, 4.34); Calibrated: 24/01/2007
- Sensor-Surface: 2 mm (Mechanical Surface Detection)
- Electronics: DAE3 Sn370; Calibrated: 13/03/2007
- Phantom: SAM 4.0; Type: Fiberglass; Serial: 1033
- Measurement SW: DASY4, V4.7 Build 44; Postprocessing SW: SEMCAD, V1.8 Build 171

Head SAR - Right Ear - Tilt Position (15°) - Low Channel/Area Scan (9x15x1):

Measurement grid: $dx=10\text{mm}$, $dy=10\text{mm}$
 Maximum value of SAR (measured) = 1.34 mW/g

Head SAR - Right Ear - Tilt Position (15°) - Low Channel/Zoom Scan (7x7x9)/Cube 0:

Measurement grid: $dx=4\text{mm}$, $dy=4\text{mm}$, $dz=2.5\text{mm}$
 Reference Value = 11.7 V/m; Power Drift = 0.0771 dB
 Peak SAR (extrapolated) = 2.64 W/kg
SAR(1 g) = 0.710 mW/g; SAR(10 g) = 0.264 mW/g
 Maximum value of SAR (measured) = 1.35 mW/g

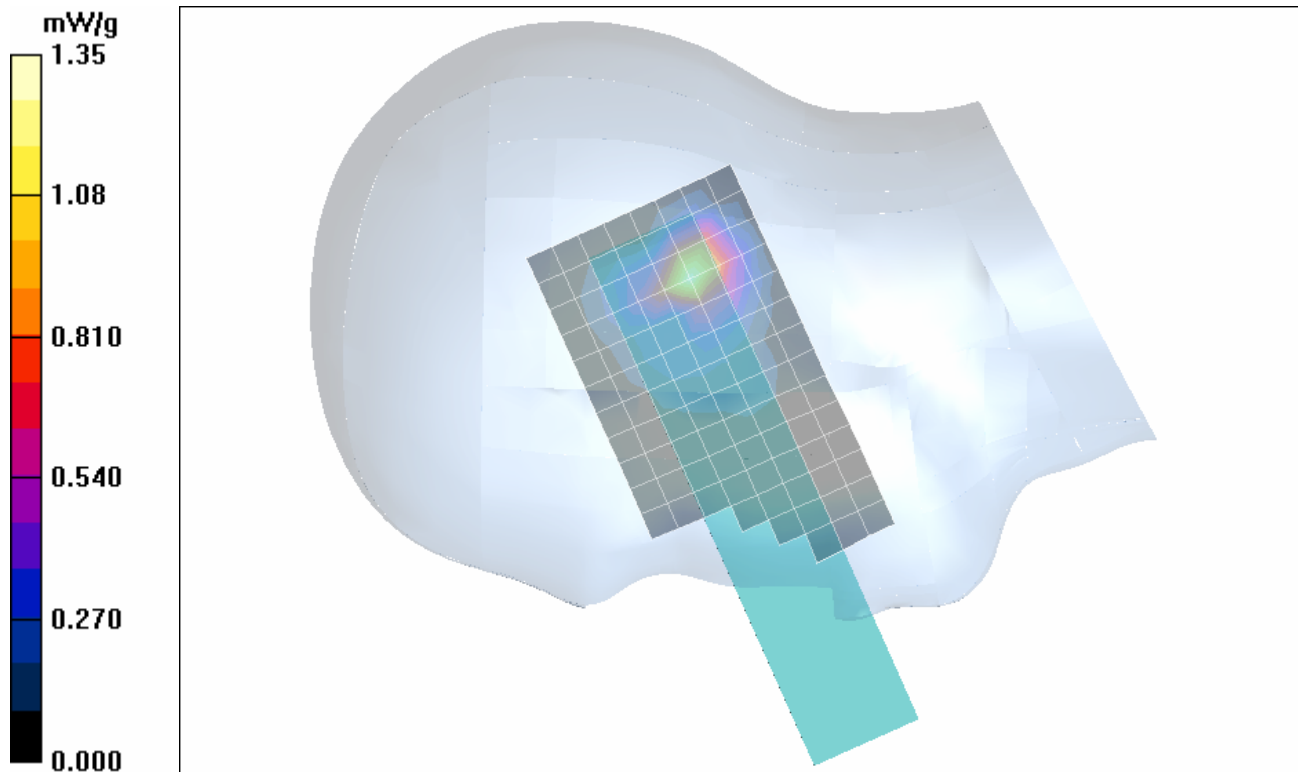

Company:	VTECH TELECOMMUNICATIONS LTD.	FCC ID:	EW780-6101-00	IC ID:	1135A-80610100	
Model(s):	LS5145 / LS5105	Portable 5.8 GHz Cordless Telephone Handset	Freq.:	5744 - 5825 MHz		
2007 Celltech Labs Inc.		This document is not to be reproduced in whole or in part without the prior written permission of Celltech Labs Inc.				Page 21 of 49

	<u>Date(s) of Evaluation</u> July 13 & 16, 2007	<u>Test Report Serial No.</u> 062107EW7-T839-S15T	<u>Report Revision No.</u> Revision 1.0	
	<u>Test Report Issue Date</u> July 20, 2007	<u>Description of Test(s)</u> Specific Absorption Rate	<u>RF Exposure Category</u> General Population	

Date Tested: 07/13/2007

Head SAR - Right Ear - Tilt Position (15°) - 5825.952 MHz - Channel 94

DUT: Vtech Model: LS5145; Type: Portable 5.8GHz Cordless Telephone Handset; Serial: 2

Ambient Temp: 23.1°C; Fluid Temp: 22.4°C; Barometric Pressure: 101.2 kPa; Humidity: 35%

Power: 3.6V, 550mAh NiMH Battery

Communication System: TDD/TDMA

Frequency: 5825.952 MHz; Duty Cycle: 1:5

RF Output Power: 117.7 dBuV/m (Field Strength)

Medium: HSL5200-5800 Medium parameters used: $f = 5825.95 \text{ MHz}$; $\sigma = 5.42 \text{ mho/m}$; $\epsilon_r = 33.1$; $\rho = 1000 \text{ kg/m}^3$

- Probe: EX3DV4 - SN3600; ConvF(4.34, 4.34, 4.34); Calibrated: 24/01/2007
- Sensor-Surface: 2 mm (Mechanical Surface Detection)
- Electronics: DAE3 Sn370; Calibrated: 13/03/2007
- Phantom: SAM 4.0; Type: Fiberglass; Serial: 1033
- Measurement SW: DASY4, V4.7 Build 44; Postprocessing SW: SEMCAD, V1.8 Build 171

Head SAR - Right Ear - Tilt Position (15°) - High Channel/Area Scan (9x15x1):

Measurement grid: $dx=10\text{mm}$, $dy=10\text{mm}$

Maximum value of SAR (measured) = 2.32 mW/g

Head SAR - Right Ear - Tilt Position (15°) - High Channel/Zoom Scan (7x7x9)/Cube 0:

Measurement grid: $dx=4\text{mm}$, $dy=4\text{mm}$, $dz=2.5\text{mm}$

Reference Value = 15.2 V/m; Power Drift = 0.0543 dB

Peak SAR (extrapolated) = 4.74 W/kg

SAR(1 g) = 1.20 mW/g; SAR(10 g) = 0.431 mW/g

Maximum value of SAR (measured) = 2.31 mW/g

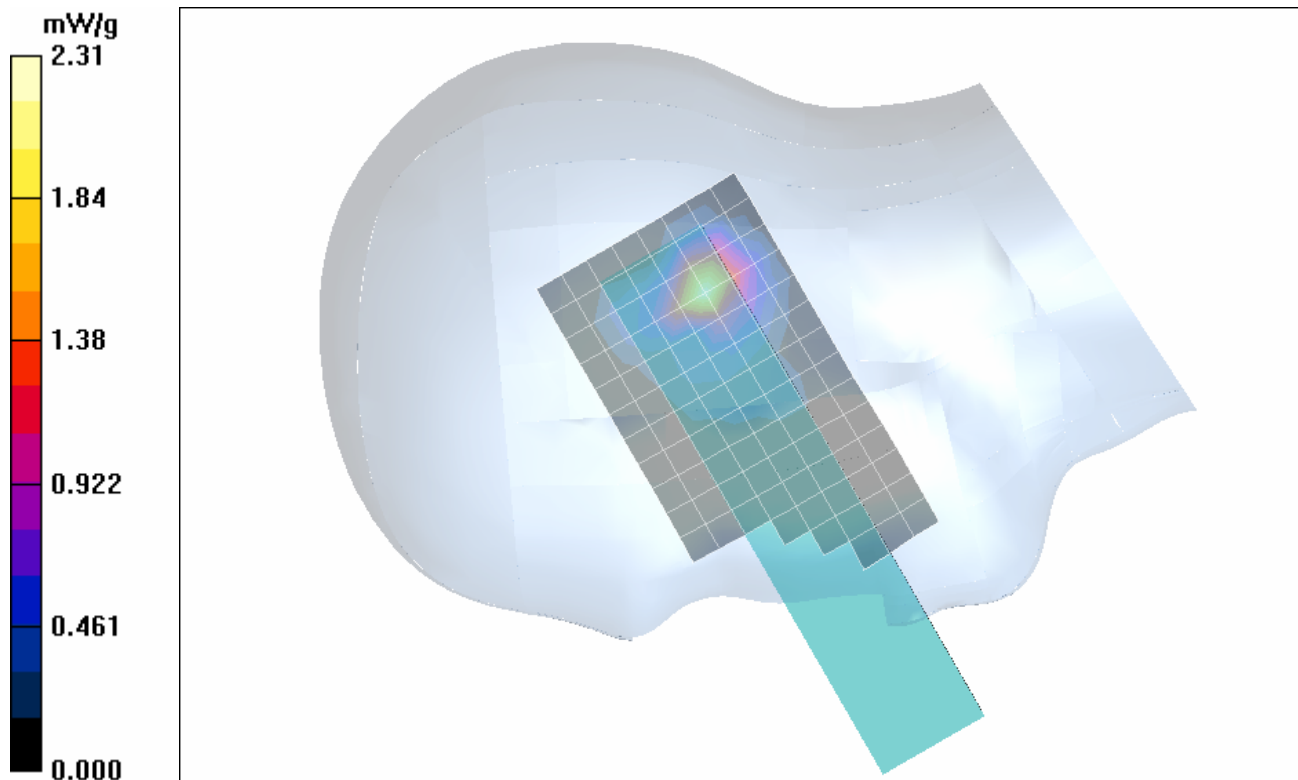

Company:	VTECH TELECOMMUNICATIONS LTD.	FCC ID:	EW780-6101-00	IC ID:	1135A-80610100	
Model(s):	LS5145 / LS5105	Portable 5.8 GHz Cordless Telephone Handset		Freq.:	5744 - 5825 MHz	
2007 Celltech Labs Inc.		This document is not to be reproduced in whole or in part without the prior written permission of Celltech Labs Inc.				Page 22 of 49

Z-Axis Scan

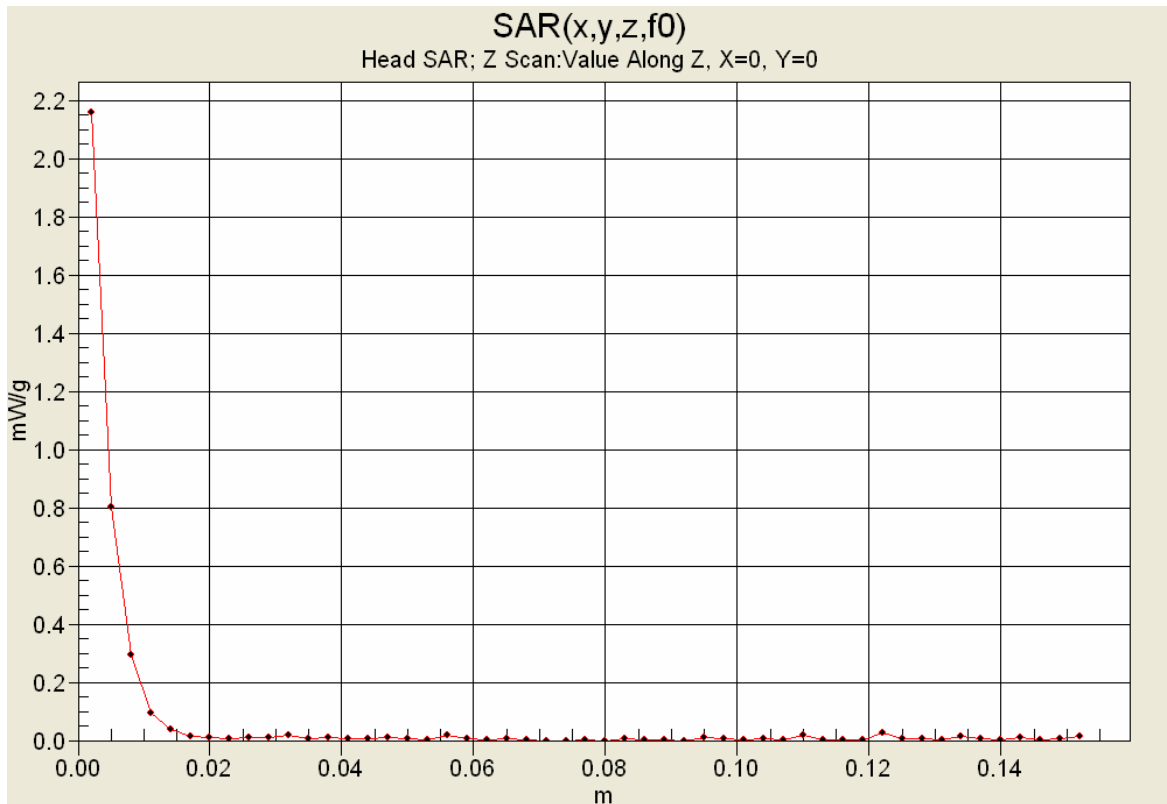

	<u>Date(s) of Evaluation</u> July 13 & 16, 2007	<u>Test Report Serial No.</u> 062107EW7-T839-S15T	<u>Report Revision No.</u> Revision 1.0	 Certificate No. 2470.01
	<u>Test Report Issue Date</u> July 20, 2007	<u>Description of Test(s)</u> Specific Absorption Rate	<u>RF Exposure Category</u> General Population	

Date Tested: 07/13/2007

Head SAR - Left Ear - Cheek/Touch Position - 5785.344 MHz - Channel 47

DUT: Vtech Model: LS5145; Type: Portable 5.8GHz Cordless Telephone Handset; Serial: 2

Ambient Temp: 23.1°C; Fluid Temp: 22.4°C; Barometric Pressure: 101.2 kPa; Humidity: 35%

Power: 3.6V, 550mAh NiMH Battery
 Communication System: TDD/TDMA
 Frequency: 5785.344 MHz; Duty Cycle: 1:5
 RF Output Power: 116.3 dBuV/m (Field Strength)
 Medium: HSL5200-5800 Medium parameters used: $f = 5785.34 \text{ MHz}$; $\sigma = 5.42 \text{ mho/m}$; $\epsilon_r = 33.1$; $\rho = 1000 \text{ kg/m}^3$
 - Probe: EX3DV4 - SN3600; ConvF(4.34, 4.34, 4.34); Calibrated: 24/01/2007
 - Sensor-Surface: 2 mm (Mechanical Surface Detection)
 - Electronics: DAE3 Sn370; Calibrated: 13/03/2007
 - Phantom: SAM 4.0; Type: Fiberglass; Serial: 1033
 - Measurement SW: DASy4, V4.7 Build 44; Postprocessing SW: SEMCAD, V1.8 Build 171

Head SAR - Left Ear - Cheek/Touch Position - Mid Channel/Area Scan (9x15x1):

Measurement grid: $dx=10\text{mm}$, $dy=10\text{mm}$
 Maximum value of SAR (measured) = 2.12 mW/g

Head SAR - Left Ear - Cheek/Touch Position - Mid Channel/Zoom Scan (7x7x9)/Cube 0:

Measurement grid: $dx=4\text{mm}$, $dy=4\text{mm}$, $dz=2.5\text{mm}$
 Reference Value = 14.1 V/m; Power Drift = 0.162 dB
 Peak SAR (extrapolated) = 4.67 W/kg
SAR(1 g) = 1.17 mW/g; SAR(10 g) = 0.422 mW/g
 Maximum value of SAR (measured) = 2.31 mW/g

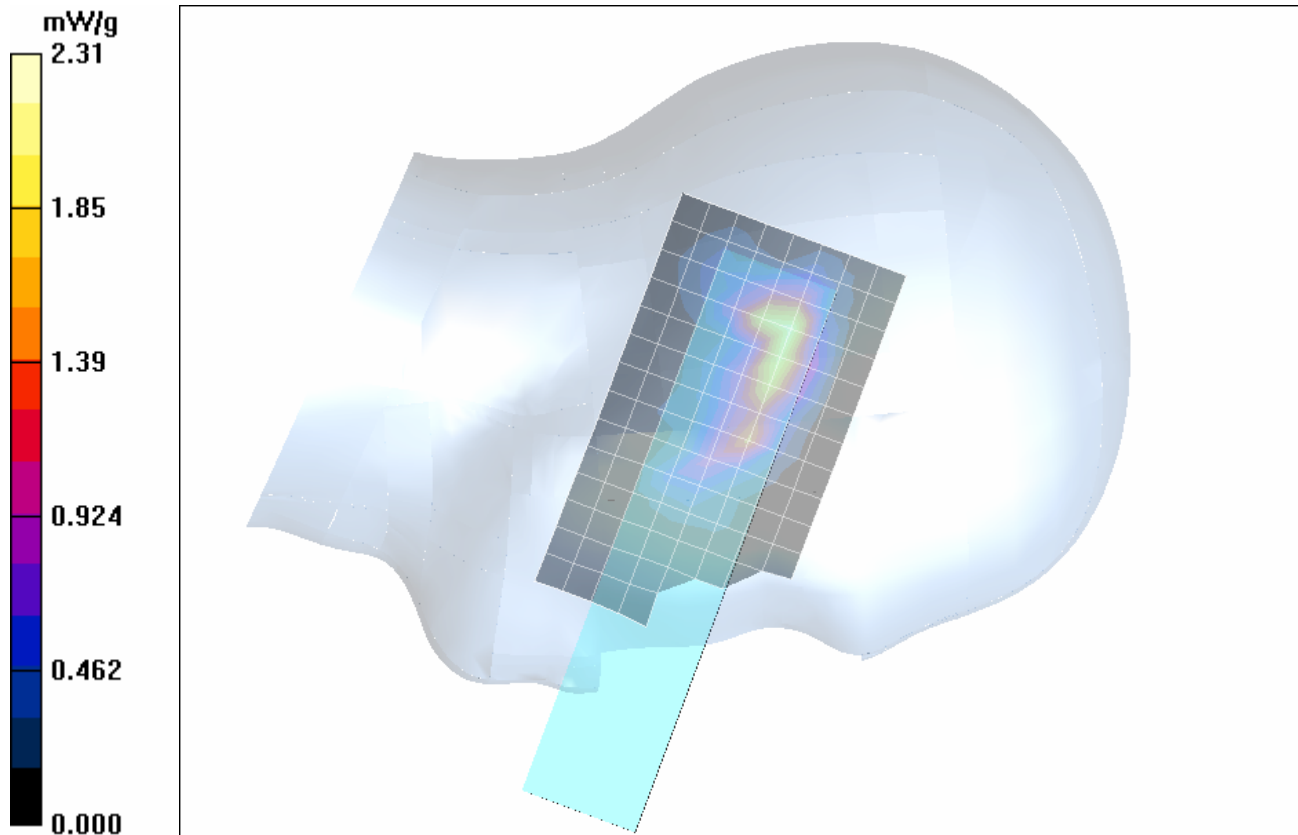

Company:	VTECH TELECOMMUNICATIONS LTD.	FCC ID:	EW780-6101-00	IC ID:	1135A-80610100	
Model(s):	LS5145 / LS5105	Portable 5.8 GHz Cordless Telephone Handset	Freq.:	5744 - 5825 MHz		
2007 Celltech Labs Inc.		This document is not to be reproduced in whole or in part without the prior written permission of Celltech Labs Inc.				Page 24 of 49

	<u>Date(s) of Evaluation</u> July 13 & 16, 2007	<u>Test Report Serial No.</u> 062107EW7-T839-S15T	<u>Report Revision No.</u> Revision 1.0	 Certificate No. 2470.01
	<u>Test Report Issue Date</u> July 20, 2007	<u>Description of Test(s)</u> Specific Absorption Rate	<u>RF Exposure Category</u> General Population	

Date Tested: 07/16/2007

Head SAR - Left Ear - Tilt Position (15°) - 5785.344 MHz - Channel 47

DUT: Vtech Model: LS5145; Type: Portable 5.8GHz Cordless Telephone Handset; Serial: 2

Ambient Temp: 23.0°C; Fluid Temp: 23.0°C; Barometric Pressure: 101.3 kPa; Humidity: 31%

Power: 3.6V, 550mAh NiMH Battery
 Communication System: TDD/TDMA
 Frequency: 5785.344 MHz; Duty Cycle: 1:5
 RF Output Power: 116.3 dBuV/m (Field Strength)
 Medium: HSL5200-5800 Medium parameters used: $f = 5785.34 \text{ MHz}$; $\sigma = 5.39 \text{ mho/m}$; $\epsilon_r = 31.9$; $\rho = 1000 \text{ kg/m}^3$

- Probe: EX3DV4 - SN3600; ConvF(4.34, 4.34, 4.34); Calibrated: 24/01/2007
- Sensor-Surface: 2 mm (Mechanical Surface Detection)
- Electronics: DAE3 Sn370; Calibrated: 13/03/2007
- Phantom: SAM 4.0; Type: Fiberglass; Serial: 1033
- Measurement SW: DASY4, V4.7 Build 44; Postprocessing SW: SEMCAD, V1.8 Build 171

Head SAR - Left Ear - Tilt Position (15°) - Mid Channel/Area Scan (9x15x1):

Measurement grid: $dx=10\text{mm}$, $dy=10\text{mm}$
 Maximum value of SAR (measured) = 1.63 mW/g

Head SAR - Left Ear - Tilt Position (15°) - Mid Channel/Zoom Scan (7x7x9)/Cube 0:

Measurement grid: $dx=4\text{mm}$, $dy=4\text{mm}$, $dz=2.5\text{mm}$
 Reference Value = 7.37 V/m; Power Drift = 0.0928 dB
 Peak SAR (extrapolated) = 5.35 W/kg
SAR(1 g) = 1.08 mW/g; SAR(10 g) = 0.290 mW/g
 Maximum value of SAR (measured) = 2.09 mW/g

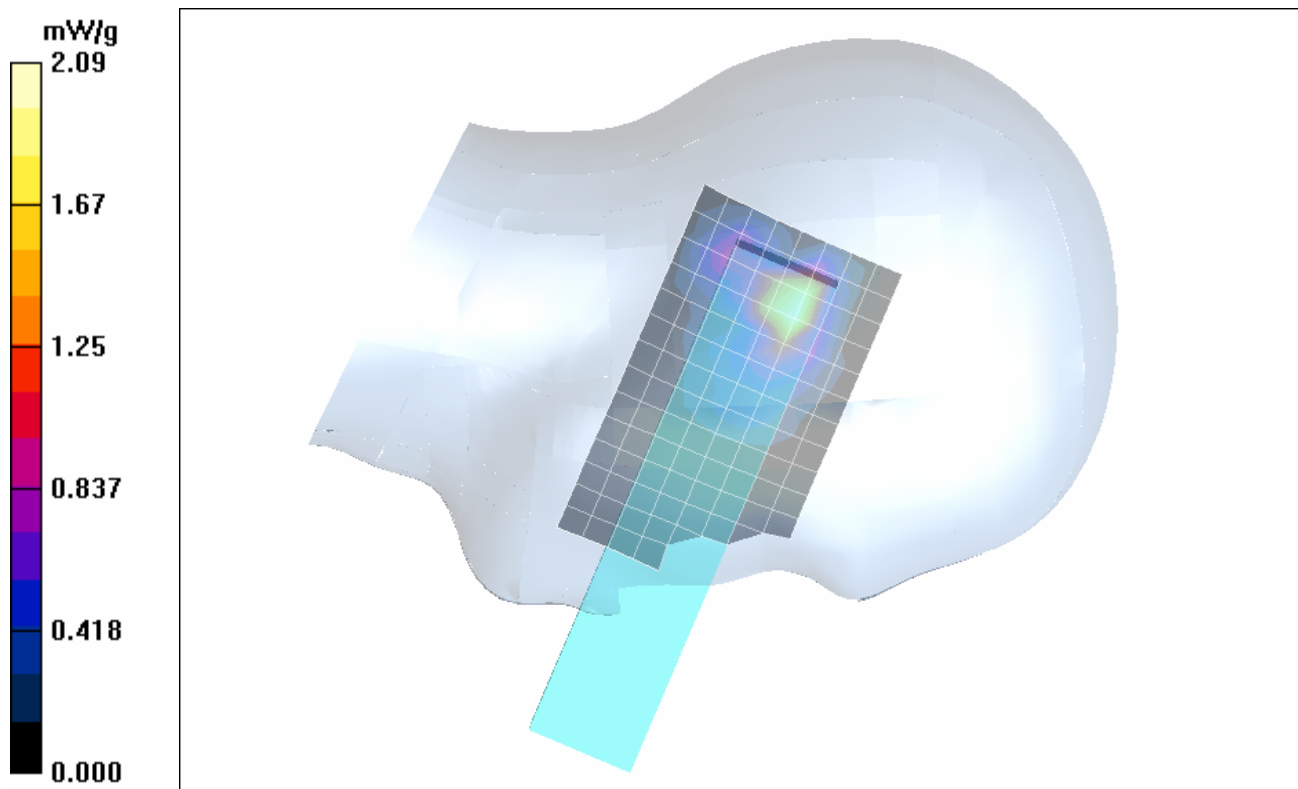

Company:	VTECH TELECOMMUNICATIONS LTD.	FCC ID:	EW780-6101-00	IC ID:	1135A-80610100	
Model(s):	LS5145 / LS5105	Portable 5.8 GHz Cordless Telephone Handset		Freq.:	5744 - 5825 MHz	
2007 Celltech Labs Inc.		This document is not to be reproduced in whole or in part without the prior written permission of Celltech Labs Inc.				Page 25 of 49

	<u>Date(s) of Evaluation</u> July 13 & 16, 2007	<u>Test Report Serial No.</u> 062107EW7-T839-S15T	<u>Report Revision No.</u> Revision 1.0	 Certificate No. 2470.01
	<u>Test Report Issue Date</u> July 20, 2007	<u>Description of Test(s)</u> Specific Absorption Rate	<u>RF Exposure Category</u> General Population	

Date Tested: 07/16/2007

Head SAR - Left Ear - Cheek/Touch Position - 5744.736 MHz - Channel 0

DUT: Vtech Model: LS5145; Type: Portable 5.8GHz Cordless Telephone Handset; Serial: 2

Ambient Temp: 23.0°C; Fluid Temp: 23.0°C; Barometric Pressure: 101.3 kPa; Humidity: 31%

Power: 3.6V, 550mAh NiMH Battery
 Communication System: TDD/TDMA
 Frequency: 5744.736 MHz; Duty Cycle: 1:5
 RF Output Power: 113.3 dBuV/m (Field Strength)
 Medium: HSL5200-5800 Medium parameters used: $f = 5744.74 \text{ MHz}$; $\sigma = 5.39 \text{ mho/m}$; $\epsilon_r = 31.9$; $\rho = 1000 \text{ kg/m}^3$

- Probe: EX3DV4 - SN3600; ConvF(4.34, 4.34, 4.34); Calibrated: 24/01/2007
- Sensor-Surface: 2 mm (Mechanical Surface Detection)
- Electronics: DAE3 Sn370; Calibrated: 13/03/2007
- Phantom: SAM 4.0; Type: Fiberglas; Serial: 1033
- Measurement SW: DASY4, V4.7 Build 44; Postprocessing SW: SEMCAD, V1.8 Build 171

Head SAR - Left Ear - Cheek/Touch Position - Low Channel/Area Scan (9x15x1):

Measurement grid: $dx=10\text{mm}$, $dy=10\text{mm}$
 Maximum value of SAR (measured) = 1.63 mW/g

Head SAR - Left Ear - Cheek/Touch Position - Low Channel/Zoom Scan (7x7x9)/Cube 0:

Measurement grid: $dx=4\text{mm}$, $dy=4\text{mm}$, $dz=2.5\text{mm}$
 Reference Value = 12.1 V/m; Power Drift = 0.0965 dB
 Peak SAR (extrapolated) = 4.07 W/kg
SAR(1 g) = 0.980 mW/g; SAR(10 g) = 0.345 mW/g
 Maximum value of SAR (measured) = 2.04 mW/g

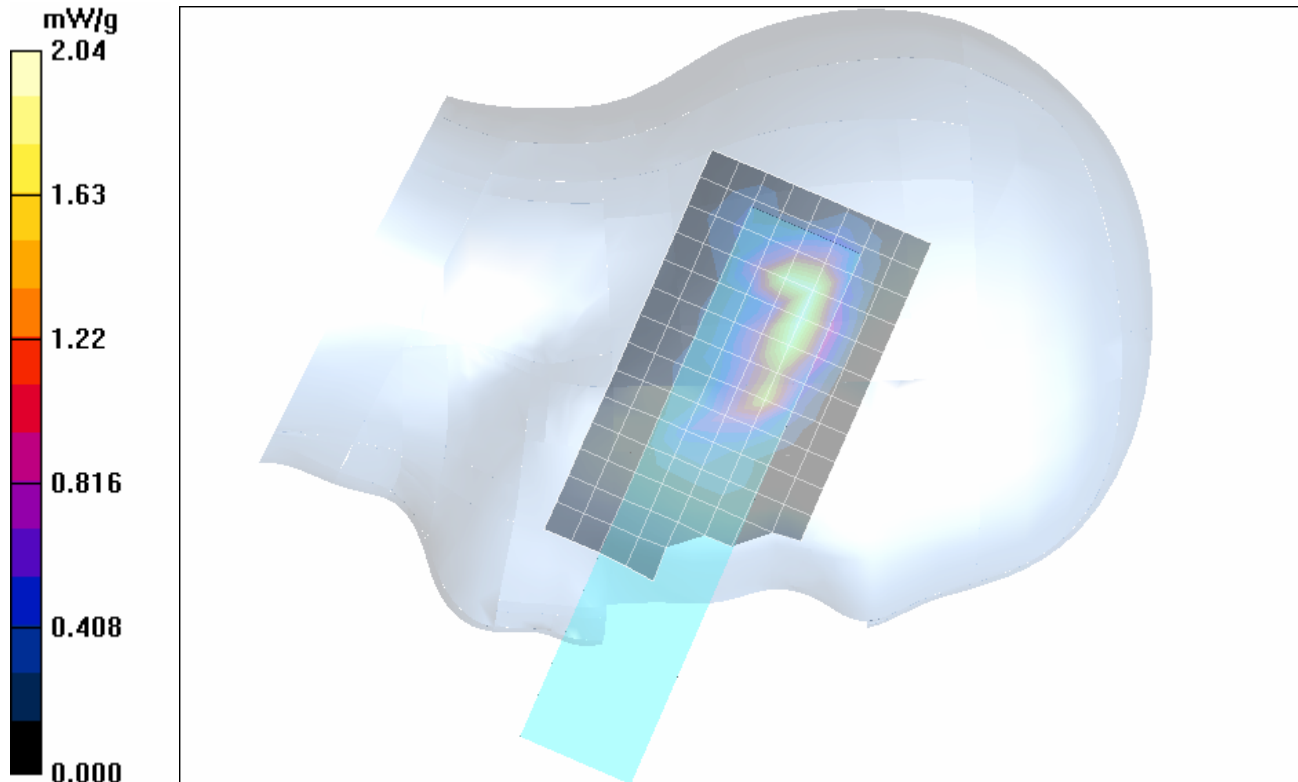

Company:	VTECH TELECOMMUNICATIONS LTD.	FCC ID:	EW780-6101-00	IC ID:	1135A-80610100	
Model(s):	LS5145 / LS5105	Portable 5.8 GHz Cordless Telephone Handset		Freq.:	5744 - 5825 MHz	
2007 Celltech Labs Inc.		This document is not to be reproduced in whole or in part without the prior written permission of Celltech Labs Inc.				Page 26 of 49

	<u>Date(s) of Evaluation</u> July 13 & 16, 2007	<u>Test Report Serial No.</u> 062107EW7-T839-S15T	<u>Report Revision No.</u> Revision 1.0	
	<u>Test Report Issue Date</u> July 20, 2007	<u>Description of Test(s)</u> Specific Absorption Rate	<u>RF Exposure Category</u> General Population	

Date Tested: 07/16/2007

Head SAR - Left Ear - Cheek/Touch Position - 5825.952 MHz - Channel 94

DUT: Vtech Model: LS5145; Type: Portable 5.8GHz Cordless Telephone Handset; Serial: 2

Ambient Temp: 23.0°C; Fluid Temp: 23.0°C; Barometric Pressure: 101.3 kPa; Humidity: 31%

Power: 3.6V, 550mAh NiMH Battery
 Communication System: TDD/TDMA
 Frequency: 5825.952 MHz; Duty Cycle: 1:5
 RF Output Power: 117.7 dBuV/m (Field Strength)
 Medium: HSL5200-5800 Medium parameters used: $f = 5825.95 \text{ MHz}$; $\sigma = 5.39 \text{ mho/m}$; $\epsilon_r = 31.9$; $\rho = 1000 \text{ kg/m}^3$

- Probe: EX3DV4 - SN3600; ConvF(4.34, 4.34, 4.34); Calibrated: 24/01/2007
- Sensor-Surface: 2 mm (Mechanical Surface Detection)
- Electronics: DAE3 Sn370; Calibrated: 13/03/2007
- Phantom: SAM 4.0; Type: Fiberglas; Serial: 1033
- Measurement SW: DASY4, V4.7 Build 44; Postprocessing SW: SEMCAD, V1.8 Build 171

Head SAR - Left Ear - Cheek/Touch Position - High Channel/Area Scan (9x15x1):

Measurement grid: $dx=10\text{mm}$, $dy=10\text{mm}$
 Maximum value of SAR (measured) = 2.81 mW/g

Head SAR - Left Ear - Cheek/Touch Position - High Channel/Zoom Scan 2 (7x7x9)/Cube 0:

Measurement grid: $dx=4\text{mm}$, $dy=4\text{mm}$, $dz=2.5\text{mm}$
 Reference Value = 12.1 V/m; Power Drift = -0.162 dB
 Peak SAR (extrapolated) = 6.41 W/kg
SAR(1 g) = 1.57 mW/g; SAR(10 g) = 0.498 mW/g
 Maximum value of SAR (measured) = 3.10 mW/g

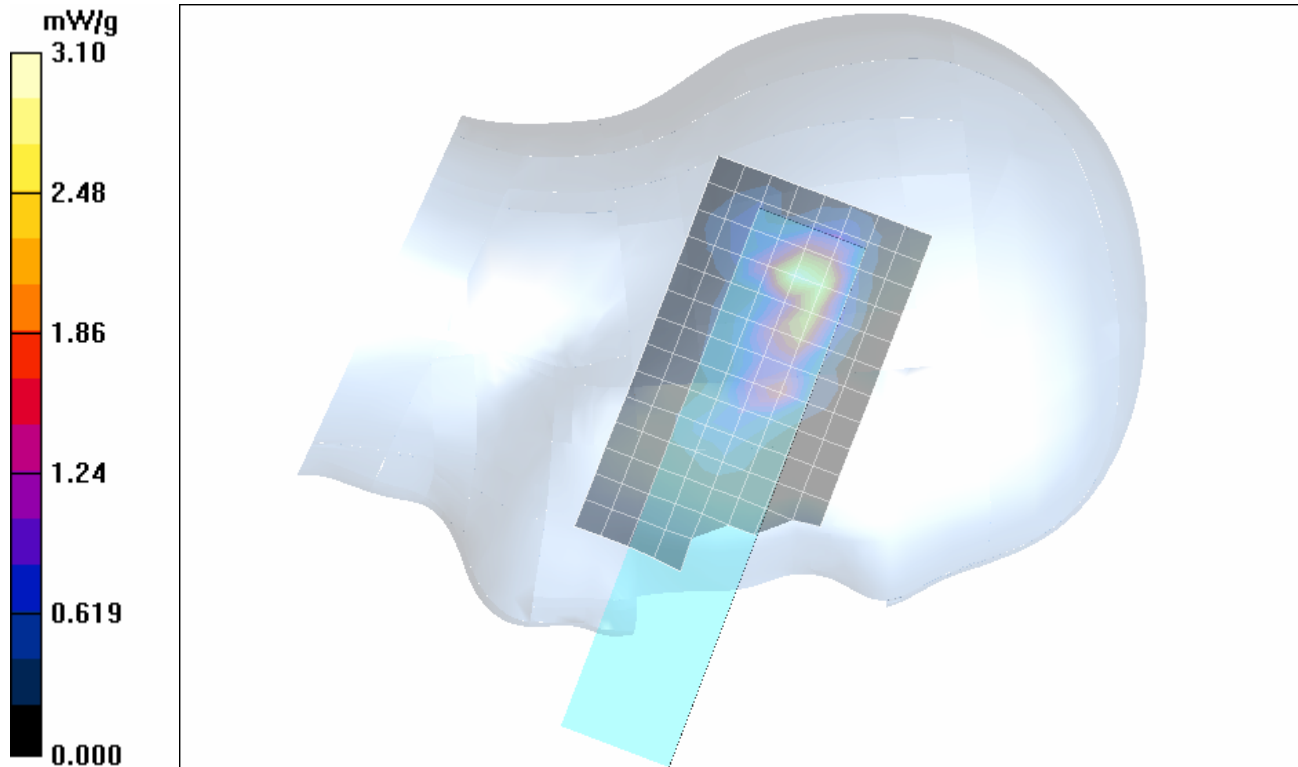

Company:	VTECH TELECOMMUNICATIONS LTD.	FCC ID:	EW780-6101-00	IC ID:	1135A-80610100	
Model(s):	LS5145 / LS5105	Portable 5.8 GHz Cordless Telephone Handset		Freq.:	5744 - 5825 MHz	
2007 Celltech Labs Inc.		This document is not to be reproduced in whole or in part without the prior written permission of Celltech Labs Inc.				Page 27 of 49

Z-Axis Scan

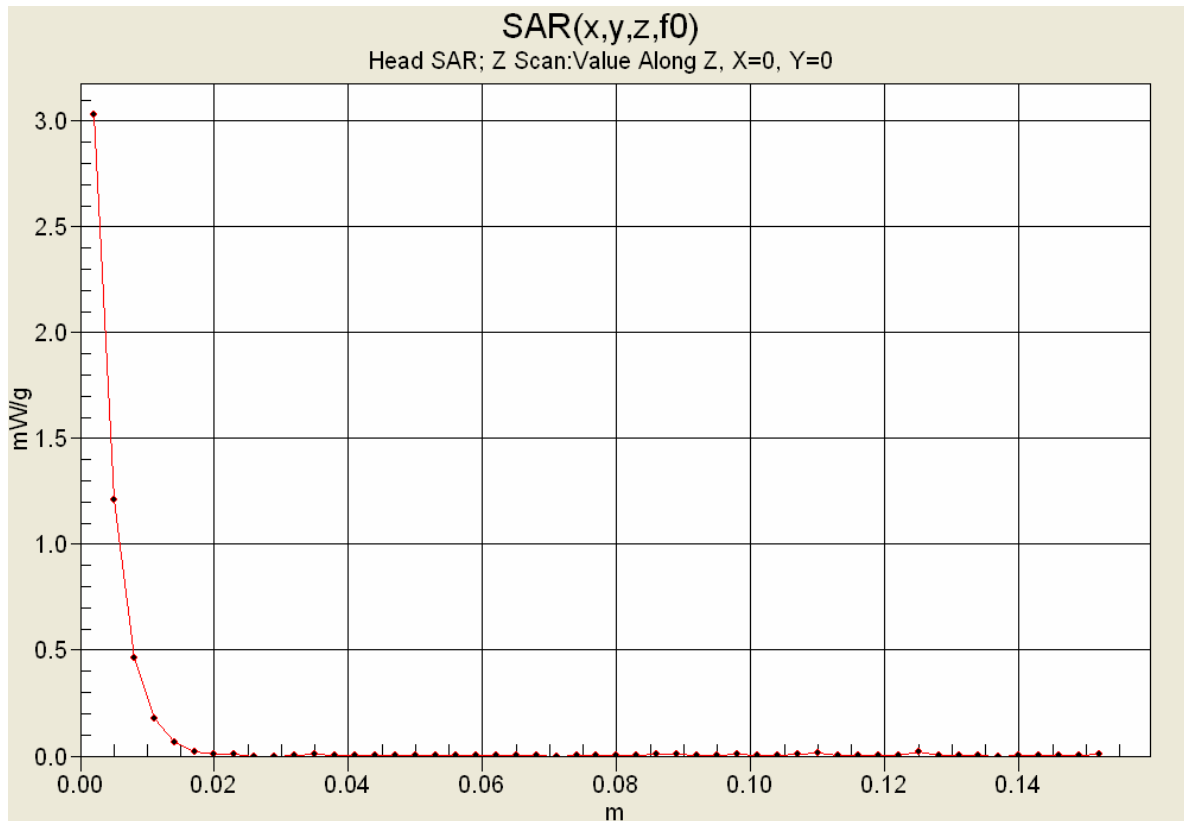

	<u>Date(s) of Evaluation</u> July 13 & 16, 2007	<u>Test Report Serial No.</u> 062107EW7-T839-S15T	<u>Report Revision No.</u> Revision 1.0	 Certificate No. 2470.01
	<u>Test Report Issue Date</u> July 20, 2007	<u>Description of Test(s)</u> Specific Absorption Rate	<u>RF Exposure Category</u> General Population	

APPENDIX B - SYSTEM PERFORMANCE CHECK DATA

Company:	VTECH TELECOMMUNICATIONS LTD.	FCC ID:	EW780-6101-00	IC ID:	1135A-80610100	
Model(s):	LS5145 / LS5105	Portable 5.8 GHz Cordless Telephone Handset		Freq.:	5744 - 5825 MHz	
2007 Celltech Labs Inc.		This document is not to be reproduced in whole or in part without the prior written permission of Celltech Labs Inc.				Page 29 of 49

	<u>Date(s) of Evaluation</u> July 13 & 16, 2007	<u>Test Report Serial No.</u> 062107EW7-T839-S15T	<u>Report Revision No.</u> Revision 1.0	 Certificate No. 2470.01
	<u>Test Report Issue Date</u> July 20, 2007	<u>Description of Test(s)</u> Specific Absorption Rate	<u>RF Exposure Category</u> General Population	

Date Tested: 07/13/2007

System Performance Check - 5800 MHz Dipole - HSL

DUT: Dipole 5GHz; Type: D5GHZV2; Serial: 1031; Validation: 05/09/2007

Ambient Temp: 23.1°C; Fluid Temp: 22.4°C; Barometric Pressure: 101.2 kPa; Humidity: 35%

Communication System: CW

Forward Conducted Power: 250 mW

Frequency: 5800 MHz; Duty Cycle: 1:1

Medium: HSL5200-5800 Medium parameters used: $f = 5800 \text{ MHz}$; $\sigma = 5.42 \text{ mho/m}$; $\epsilon_r = 33.1$; $\rho = 1000 \text{ kg/m}^3$

- Probe: EX3DV4 - SN3600; ConvF(4.34, 4.34, 4.34); Calibrated: 24/01/2007
- Sensor-Surface: 2mm (Mechanical Surface Detection)
- Electronics: DAE3 Sn370; Calibrated: 13/03/2007
- Phantom: SAM 4.0; Type: Fiberglas; Serial: 1033
- Measurement SW: DASY4, V4.7 Build 44; Postprocessing SW: SEMCAD, V1.8 Build 171

5800 MHz Dipole - System Performance Check/Area Scan (9x13x1):

Measurement grid: dx=5mm, dy=5mm

Maximum value of SAR (measured) = 43.1 mW/g

5800 MHz Dipole - System Performance Check/Zoom Scan (7x7x9)/Cube 0:

Measurement grid: dx=4mm, dy=4mm, dz=2.5mm

Reference Value = 95.1 V/m; Power Drift = -0.148 dB

Peak SAR (extrapolated) = 91.6 W/kg

SAR(1 g) = 20.5 mW/g; SAR(10 g) = 5.77 mW/g

Maximum value of SAR (measured) = 44.0 mW/g

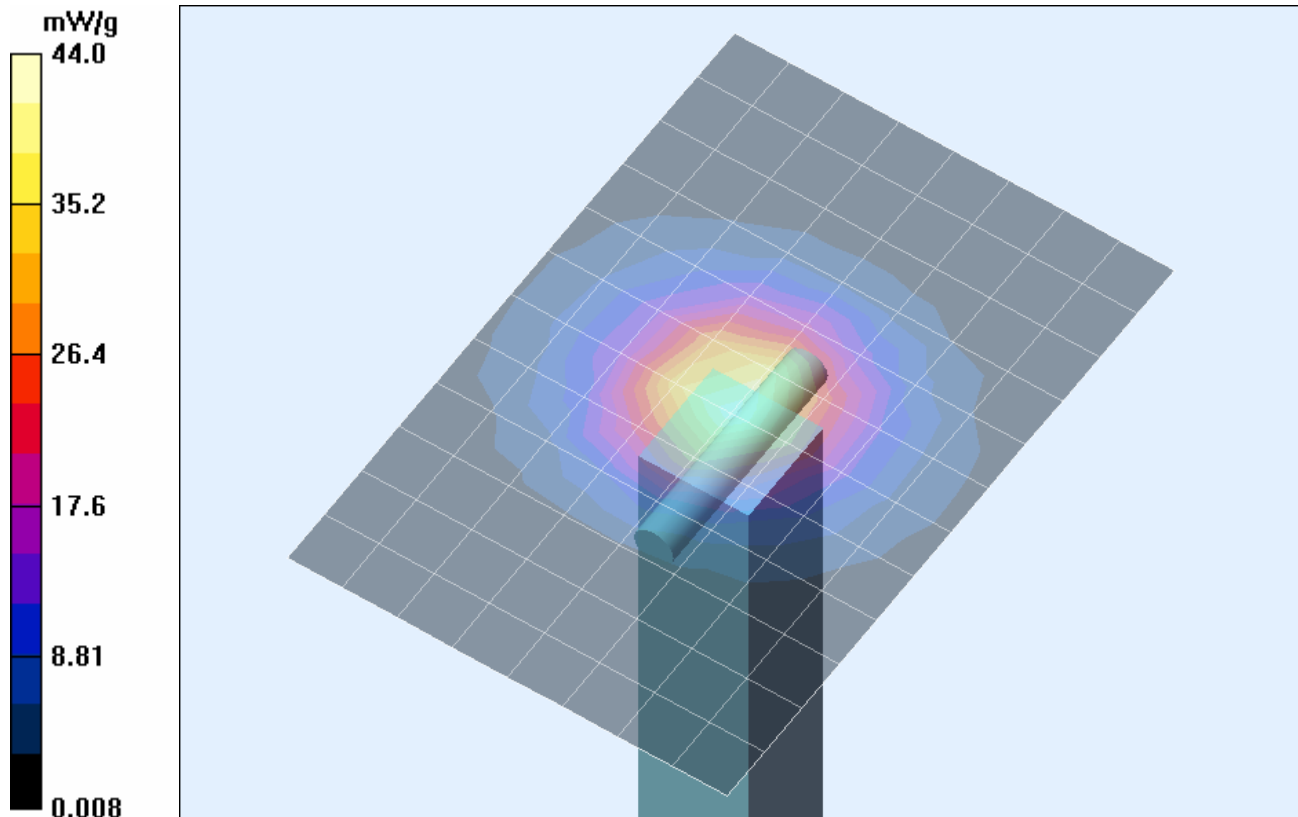

Company:	VTECH TELECOMMUNICATIONS LTD.	FCC ID:	EW780-6101-00	IC ID:	1135A-80610100	
Model(s):	LS5145 / LS5105	Portable 5.8 GHz Cordless Telephone Handset		Freq.:	5744 - 5825 MHz	
2007 Celltech Labs Inc.		This document is not to be reproduced in whole or in part without the prior written permission of Celltech Labs Inc.				Page 30 of 49

Z-Axis Scan

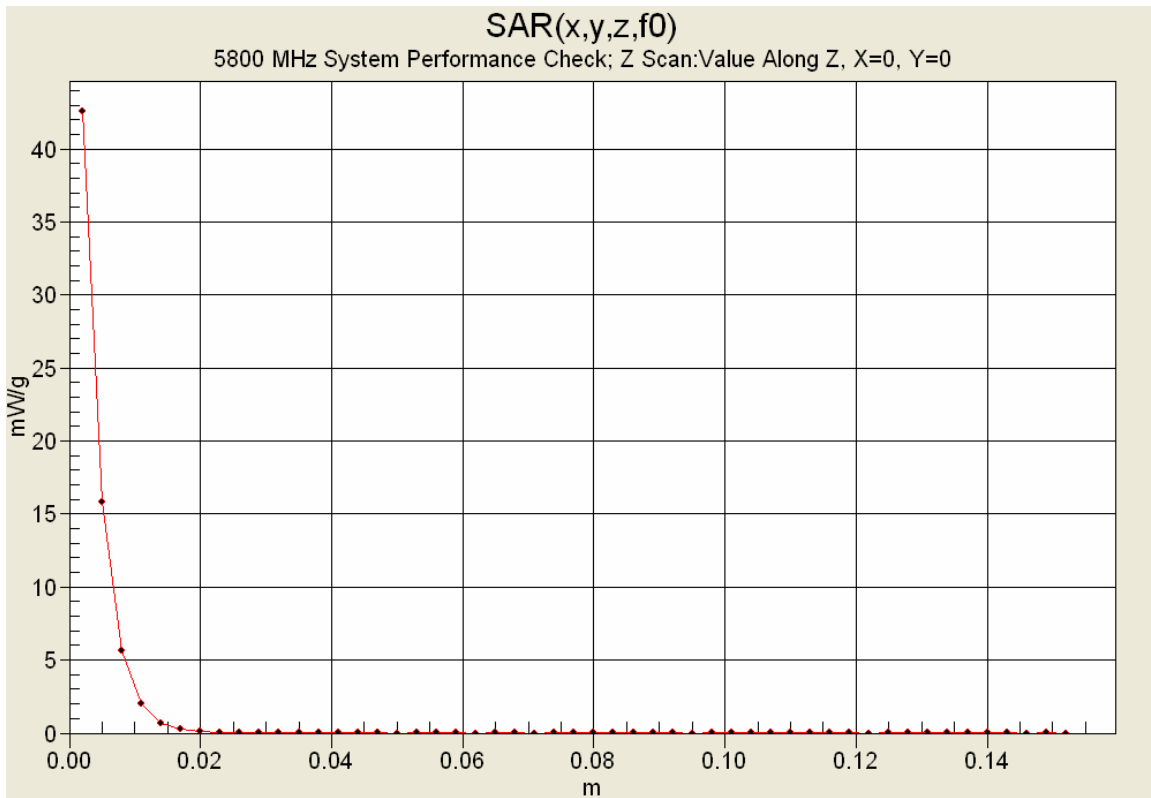

	<u>Date(s) of Evaluation</u> July 13 & 16, 2007	<u>Test Report Serial No.</u> 062107EW7-T839-S15T	<u>Report Revision No.</u> Revision 1.0	
	<u>Test Report Issue Date</u> July 20, 2007	<u>Description of Test(s)</u> Specific Absorption Rate	<u>RF Exposure Category</u> General Population	

Date Tested: 07/16/2007

System Performance Check - 5800 MHz Dipole - HSL

DUT: Dipole 5GHz; Type: D5GHZV2; Serial: 1031; Validation: 05/09/2007

Ambient Temp: 23.0°C; Fluid Temp: 23.0°C; Barometric Pressure: 101.3 kPa; Humidity: 31%

Communication System: CW

Forward Conducted Power: 250 mW

Frequency: 5800 MHz; Duty Cycle: 1:1

Medium: HSL5200-5800 Medium parameters used: $f = 5800 \text{ MHz}$; $\sigma = 5.39 \text{ mho/m}$; $\epsilon_r = 31.9$; $\rho = 1000 \text{ kg/m}^3$

- Probe: EX3DV4 - SN3600; ConvF(4.34, 4.34, 4.34); Calibrated: 24/01/2007
- Sensor-Surface: 2mm (Mechanical Surface Detection)
- Electronics: DAE3 Sn370; Calibrated: 13/03/2007
- Phantom: SAM 4.0; Type: Fiberglass; Serial: 1033
- Measurement SW: DASy4, V4.7 Build 44; Postprocessing SW: SEMCAD, V1.8 Build 171

5800 MHz Dipole - System Performance Check/Area Scan (9x13x1):

Measurement grid: dx=5mm, dy=5mm

Maximum value of SAR (measured) = 41.2 mW/g

5800 MHz Dipole - System Performance Check/Zoom Scan (7x7x9)/Cube 0:

Measurement grid: dx=4mm, dy=4mm, dz=2.5mm

Reference Value = 91.7 V/m; Power Drift = -0.049 dB

Peak SAR (extrapolated) = 89.1 W/kg

SAR(1 g) = 19.5 mW/g; SAR(10 g) = 5.54 mW/g

Maximum value of SAR (measured) = 42.2 mW/g

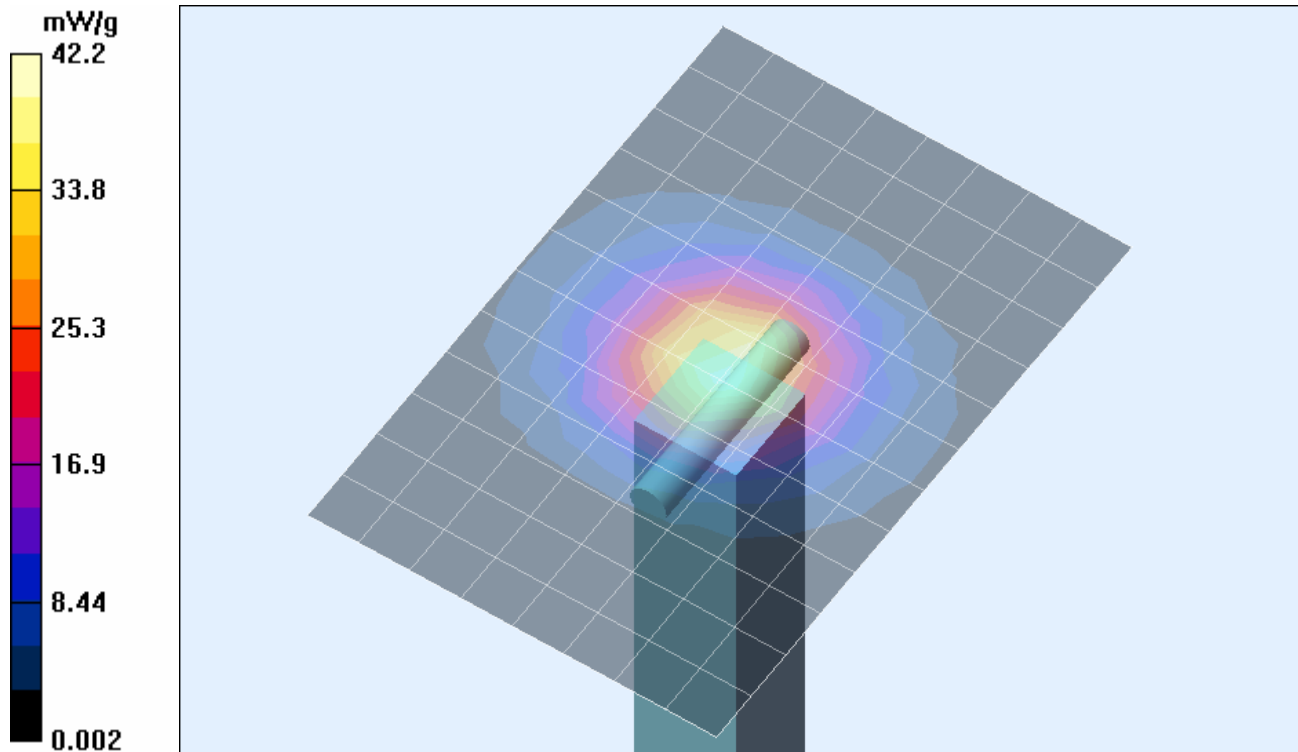

Company:	VTECH TELECOMMUNICATIONS LTD.	FCC ID:	EW780-6101-00	IC ID:	1135A-80610100	
Model(s):	LS5145 / LS5105	Portable 5.8 GHz Cordless Telephone Handset		Freq.:	5744 - 5825 MHz	
2007 Celltech Labs Inc.		This document is not to be reproduced in whole or in part without the prior written permission of Celltech Labs Inc.				Page 32 of 49

Z-Axis Scan

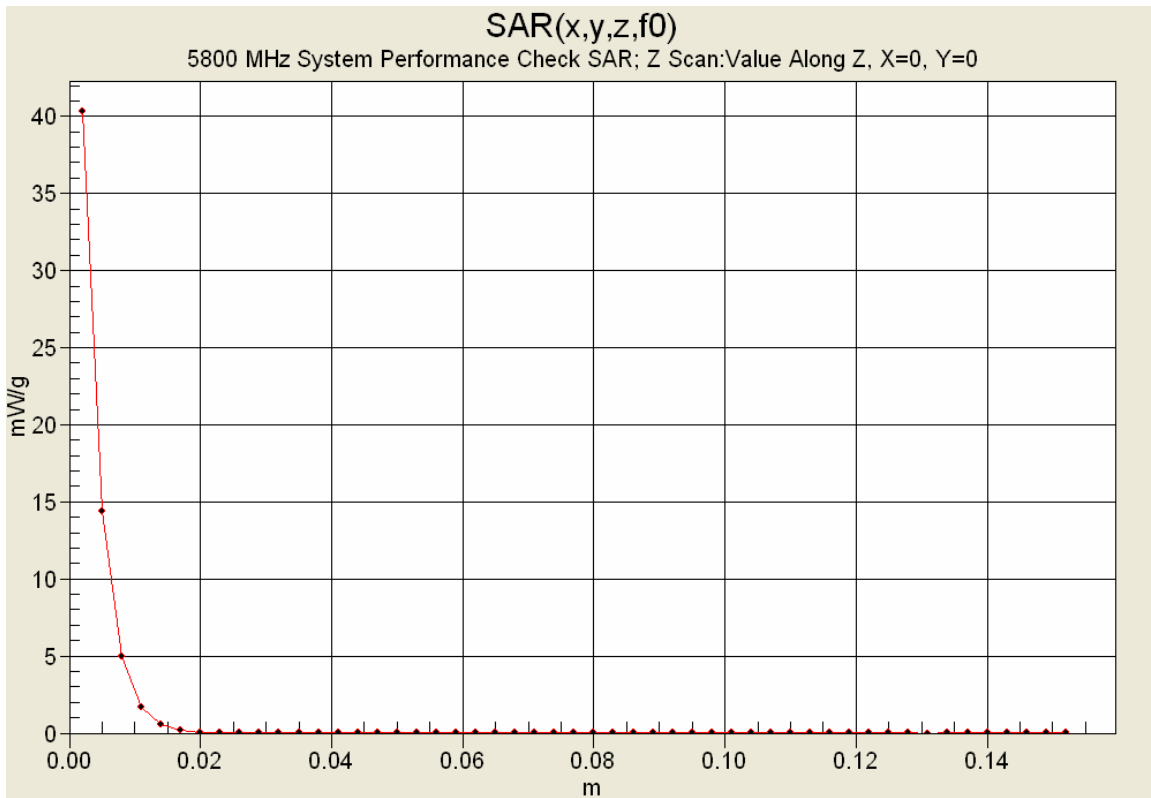

	<u>Date(s) of Evaluation</u> July 13 & 16, 2007	<u>Test Report Serial No.</u> 062107EW7-T839-S15T	<u>Report Revision No.</u> Revision 1.0	 Certificate No. 2470.01
	<u>Test Report Issue Date</u> July 20, 2007	<u>Description of Test(s)</u> Specific Absorption Rate	<u>RF Exposure Category</u> General Population	

APPENDIX C - MEASURED FLUID DIELECTRIC PARAMETERS

Company:	VTECH TELECOMMUNICATIONS LTD.	FCC ID:	EW780-6101-00	IC ID:	1135A-80610100	
Model(s):	LS5145 / LS5105	Portable 5.8 GHz Cordless Telephone Handset		Freq.:	5744 - 5825 MHz	
2007 Celltech Labs Inc.		This document is not to be reproduced in whole or in part without the prior written permission of Celltech Labs Inc.				Page 34 of 49

	<u>Date(s) of Evaluation</u> July 13 & 16, 2007	<u>Test Report Serial No.</u> 062107EW7-T839-S15T	<u>Report Revision No.</u> Revision 1.0	 Certificate No. 2470.01
	<u>Test Report Issue Date</u> July 20, 2007	<u>Description of Test(s)</u> Specific Absorption Rate	<u>RF Exposure Category</u> General Population	

5800 MHz System Performance Check & DUT Evaluation (Brain)

Celltech Labs Inc.
Test Result for UIM Dielectric Parameter
Fri 13/Jul/2007
Frequency (GHz)
FCC_eHFCC OET 65 Supplement C (June 2001) Limits for Head Epsilon
FCC_sHFCC OET 65 Supplement C (June 2001) Limits for Head Sigma
Test_e Epsilon of UIM
Test_s Sigma of UIM

Freq	FCC_eHFCC	sHFCC	Test_e	Test_s
5.7000	35.41	5.17	33.25	5.34
5.7100	35.40	5.18	33.29	5.32
5.7200	35.39	5.19	33.30	5.35
5.7300	35.38	5.20	33.27	5.38
5.7400	35.37	5.21	33.30	5.39
5.7500	35.36	5.22	33.17	5.40
5.7600	35.35	5.23	33.19	5.40
5.7700	35.33	5.24	33.20	5.39
5.7800	35.32	5.25	33.15	5.42
5.7900	35.31	5.26	33.22	5.44
5.8000	35.30	5.27	33.08	5.42
5.8100	35.29	5.28	33.18	5.46
5.8200	35.28	5.29	33.07	5.45
5.8300	35.27	5.30	33.13	5.49
5.8400	35.25	5.31	33.11	5.47
5.8500	35.24	5.32	33.00	5.53
5.8600	35.23	5.33	33.10	5.50
5.8700	35.22	5.34	33.01	5.50
5.8800	35.21	5.35	33.02	5.53
5.8900	35.20	5.36	33.12	5.56
5.9000	35.19	5.37	32.97	5.57

Company:	VTECH TELECOMMUNICATIONS LTD.	FCC ID:	EW780-6101-00	IC ID:	1135A-80610100	
Model(s):	LS5145 / LS5105	Portable 5.8 GHz Cordless Telephone Handset		Freq.:	5744 - 5825 MHz	
2007 Celltech Labs Inc.		This document is not to be reproduced in whole or in part without the prior written permission of Celltech Labs Inc.				Page 35 of 49

	<u>Date(s) of Evaluation</u> July 13 & 16, 2007	<u>Test Report Serial No.</u> 062107EW7-T839-S15T	<u>Report Revision No.</u> Revision 1.0	 Certificate No. 2470.01
	<u>Test Report Issue Date</u> July 20, 2007	<u>Description of Test(s)</u> Specific Absorption Rate	<u>RF Exposure Category</u> General Population	

5800 MHz System Performance Check & DUT Evaluation (Brain)

Celltech Labs Inc.
Test Result for UIM Dielectric Parameter
Mon 16/Jul/2007
Frequency (GHz)
FCC_eHFCC OET 65 Supplement C (June 2001) Limits for Head Epsilon
FCC_sHFCC OET 65 Supplement C (June 2001) Limits for Head Sigma
Test_e Epsilon of UIM
Test_s Sigma of UIM

Freq	FCC_eHFCC	sHFCC	Test_e	Test_s
5.7000	35.41	5.17	31.96	5.31
5.7100	35.40	5.18	31.95	5.30
5.7200	35.39	5.19	31.88	5.34
5.7300	35.38	5.20	31.96	5.32
5.7400	35.37	5.21	31.92	5.35
5.7500	35.36	5.22	31.98	5.34
5.7600	35.35	5.23	31.88	5.36
5.7700	35.33	5.24	31.92	5.37
5.7800	35.32	5.25	31.87	5.35
5.7900	35.31	5.26	31.93	5.38
5.8000	35.30	5.27	31.94	5.39
5.8100	35.29	5.28	31.82	5.37
5.8200	35.28	5.29	31.79	5.42
5.8300	35.27	5.30	31.78	5.40
5.8400	35.25	5.31	31.80	5.43
5.8500	35.24	5.32	31.78	5.44
5.8600	35.23	5.33	31.85	5.44
5.8700	35.22	5.34	31.86	5.46
5.8800	35.21	5.35	31.69	5.46
5.8900	35.20	5.36	31.75	5.47
5.9000	35.19	5.37	31.70	5.47

Company:	VTECH TELECOMMUNICATIONS LTD.	FCC ID:	EW780-6101-00	IC ID:	1135A-80610100	
Model(s):	LS5145 / LS5105	Portable 5.8 GHz Cordless Telephone Handset		Freq.:	5744 - 5825 MHz	
2007 Celltech Labs Inc.		This document is not to be reproduced in whole or in part without the prior written permission of Celltech Labs Inc.				Page 36 of 49

	<u>Date(s) of Evaluation</u> July 13 & 16, 2007	<u>Test Report Serial No.</u> 062107EW7-T839-S15T	<u>Report Revision No.</u> Revision 1.0	 Certificate No. 2470.01
	<u>Test Report Issue Date</u> July 20, 2007	<u>Description of Test(s)</u> Specific Absorption Rate	<u>RF Exposure Category</u> General Population	

APPENDIX D - MANUFACTURER'S TISSUE SIMULANT DATA SHEET

Company:	VTECH TELECOMMUNICATIONS LTD.	FCC ID:	EW780-6101-00	IC ID:	1135A-80610100	
Model(s):	LS5145 / LS5105	Portable 5.8 GHz Cordless Telephone Handset		Freq.:	5744 - 5825 MHz	
2007 Celltech Labs Inc.		This document is not to be reproduced in whole or in part without the prior written permission of Celltech Labs Inc.				Page 37 of 49

	<u>Date(s) of Evaluation</u> July 13 & 16, 2007	<u>Test Report Serial No.</u> 062107EW7-T839-S15T	<u>Report Revision No.</u> Revision 1.0	 Certificate No. 2470.01
	<u>Test Report Issue Date</u> July 20, 2007	<u>Description of Test(s)</u> Specific Absorption Rate	<u>RF Exposure Category</u> General Population	

Schmid & Partner Engineering AG

s p e a g

Zeughausstrasse 43, 8004 Zurich, Switzerland
Phone +41 1 245 9700, Fax +41 1 245 9779
info@speag.com, http://www.speag.com

Material Safety Data Sheet

1 Identification of the substance and of the manufacturer / origin

Item	Head Tissue Simulation Liquid HSL5800 Muscle Tissue Simulation Liquid MSL 5800
Type No	SL AAH 580, SL AAM 580
Series No	N/A
Manufacturer / Origin	Schmid & Partner Engineering AG Zeughausstrasse 43 8004 Zürich Switzerland Phone +41 1 245 9700, Fax +41 1 245 9779, support@speag.com

Use of the substance:

Liquid simulating physical parameters of Head or Muscle Tissue in the RF range to 6GHz.

2 Composition / Information on ingredients

The Item is composed of the following ingredients:

Water	64 - 78%
Mineral Oil	11 - 18%
Emulsifiers	9 - 15%
Additives and Salt	2 - 3%

Safety relevant ingredients according to EU directives:

CAS-No 107-41-5	< 4%	2-Methyl-2,4-pentandiol (Hexylene Glycol): Xi irritant, R36/38 irritant for eyes and skin
CAS-No 770-35-4	< 2%	1-Phenoxy-2-propanol (Propylene Glycol Phenyl Ether): Xi irritant, R36 irritant for eyes
CAS-No 93-83-4	< 2%	N,N-bis(2-Hydroxyethyl)oleamide: Xi irritant, R36/38 irritant for eyes and skin
CAS-No 9004-95-9	< 0.5%	Polyethylene glycol cetyl ether: Xi irritant, R22 harmful if swallowed, R36/38 irritant for eyes and skin R50 Very toxic to aquatic organisms

According to EU guidelines and Swiss rules, the product is not a dangerous mixture and therefore not required to be marked by symbols.

3 Hazards identification

Identification not required.

4 First aid measures

The product reacts slightly alkaline.

After skin contact:	Wash with fresh water and mild sope
After eye contact:	Rinse out with plenty of water for several minutes with the eyelid held open. Consult an ophthalmologist if necessary.
After ingestion:	Do not induce vomiting. Get medical attention.

5 Fire-fighting measures

Firefighting media	CO2, foam, dry chemical
Combustion products	Carbon oxides, nitrogen and traces of oxides of chlorine and sulfur, HCl

Due to the high water content, the liquid is self-extinguishing.

Company:	VTECH TELECOMMUNICATIONS LTD.	FCC ID:	EW780-6101-00	IC ID:	1135A-80610100	
Model(s):	LS5145 / LS5105	Portable 5.8 GHz Cordless Telephone Handset		Freq.:	5744 - 5825 MHz	
2007 Celltech Labs Inc.		This document is not to be reproduced in whole or in part without the prior written permission of Celltech Labs Inc.				Page 38 of 49

	<u>Date(s) of Evaluation</u> July 13 & 16, 2007	<u>Test Report Serial No.</u> 062107EW7-T839-S15T	<u>Report Revision No.</u> Revision 1.0	 Certificate No. 2470.01
	<u>Test Report Issue Date</u> July 20, 2007	<u>Description of Test(s)</u> Specific Absorption Rate	<u>RF Exposure Category</u> General Population	

6 Accidental release measures

Person-related precaution measures: wash with water and mild soap.
Environmental-protection measures: do not allow to enter sewerage system.
Procedures for cleaning / absorption: Use oil-binding agents., forward for disposal. Spills may cause slippery conditions.

7 Handling and storage

Handling: Keep in open container only for minimum required time in order to avoid water evaporation.
Storage: tightly closed, between >0 to 40°C. Avoid direct solar irradiation of the storage containers.

8 Exposure controls / personal protection

Protection measures are not generally required. For eye protection, industrial safety glasses are recommended.
Personal hygiene and clean working practices are sufficient.

9 Physical and chemical properties

Form: liquid
Colour: medium to dark brown, transparent to opaque
Odour: almost odourless / slightly oily
pH-Value: slightly alcalic
Boiling point: 100°C
Density: 1g/cm³

10 Stability and reactivity

Conditions to be avoided: heating above 40°C
The product contains water and is not compatible with strong oxidizers or magnesium.

11 Toxicological information

LD50 > 40 g/kg
Further data: the product should be handled with the care usual when dealing with chemicals

12 Ecological information

Contains mineral oil. Do not allow to enter waters, waste water, or soil!

13 Disposal considerations

Disposal is possible by splitting the mineral oil from the emulsion with absorbing agents, with salt or ultra-filtration. Dispose as other mineral oil containing products according to local regulations.
Product packing must be disposed of in compliance with respect national regulations.

14 Transport information

Not subject to transport regulations.

15 Regulatory information

No special labelling required.

16 Other information

Release date: 6.1.2005
Responsible: FB

Company:	VTECH TELECOMMUNICATIONS LTD.	FCC ID:	EW780-6101-00	IC ID:	1135A-80610100	
Model(s):	LS5145 / LS5105	Portable 5.8 GHz Cordless Telephone Handset		Freq.:	5744 - 5825 MHz	
2007 Celltech Labs Inc.		This document is not to be reproduced in whole or in part without the prior written permission of Celltech Labs Inc.				Page 39 of 49

	<u>Date(s) of Evaluation</u> July 13 & 16, 2007	<u>Test Report Serial No.</u> 062107EW7-T839-S15T	<u>Report Revision No.</u> Revision 1.0	 Certificate No. 2470.01
	<u>Test Report Issue Date</u> July 20, 2007	<u>Description of Test(s)</u> Specific Absorption Rate	<u>RF Exposure Category</u> General Population	

APPENDIX E - SAR TEST SETUP & DUT PHOTOGRAPHS

Company:	VTECH TELECOMMUNICATIONS LTD.	FCC ID:	EW780-6101-00	IC ID:	1135A-80610100	
Model(s):	LS5145 / LS5105	Portable 5.8 GHz Cordless Telephone Handset		Freq.:	5744 - 5825 MHz	
2007 Celltech Labs Inc.		This document is not to be reproduced in whole or in part without the prior written permission of Celltech Labs Inc.				Page 40 of 49

	<u>Date(s) of Evaluation</u> July 13 & 16, 2007	<u>Test Report Serial No.</u> 062107EW7-T839-S15T	<u>Report Revision No.</u> Revision 1.0	 Certificate No. 2470.01
	<u>Test Report Issue Date</u> July 20, 2007	<u>Description of Test(s)</u> Specific Absorption Rate	<u>RF Exposure Category</u> General Population	

HEAD SAR TEST SETUP PHOTOGRAPHS
Right Head Section / Cheek-Touch Position



Company:	VTECH TELECOMMUNICATIONS LTD.	FCC ID:	EW780-6101-00	IC ID:	1135A-80610100	
Model(s):	LS5145 / LS5105	Portable 5.8 GHz Cordless Telephone Handset	Freq.:	5744 - 5825 MHz		
2007 Celltech Labs Inc.		This document is not to be reproduced in whole or in part without the prior written permission of Celltech Labs Inc.				Page 41 of 49

	<u>Date(s) of Evaluation</u> July 13 & 16, 2007	<u>Test Report Serial No.</u> 062107EW7-T839-S15T	<u>Report Revision No.</u> Revision 1.0	 Certificate No. 2470.01
	<u>Test Report Issue Date</u> July 20, 2007	<u>Description of Test(s)</u> Specific Absorption Rate	<u>RF Exposure Category</u> General Population	

HEAD SAR TEST SETUP PHOTOGRAPHS
Right Head Section / Ear-Tilt Position (15°)



Company:	VTECH TELECOMMUNICATIONS LTD.	FCC ID:	EW780-6101-00	IC ID:	1135A-80610100	
Model(s):	LS5145 / LS5105	Portable 5.8 GHz Cordless Telephone Handset	Freq.:	5744 - 5825 MHz		
2007 Celltech Labs Inc.		This document is not to be reproduced in whole or in part without the prior written permission of Celltech Labs Inc.				Page 42 of 49

	<u>Date(s) of Evaluation</u> July 13 & 16, 2007	<u>Test Report Serial No.</u> 062107EW7-T839-S15T	<u>Report Revision No.</u> Revision 1.0	 Certificate No. 2470.01
	<u>Test Report Issue Date</u> July 20, 2007	<u>Description of Test(s)</u> Specific Absorption Rate	<u>RF Exposure Category</u> General Population	

HEAD SAR TEST SETUP PHOTOGRAPHS
Left Head Section / Cheek-Touch Position

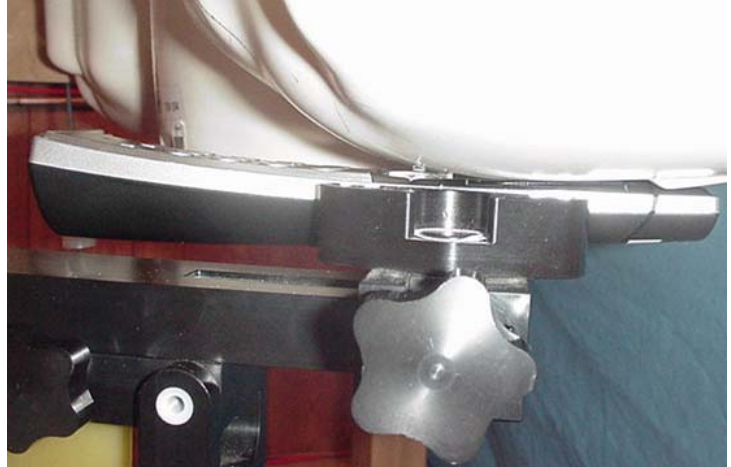

Company:	VTECH TELECOMMUNICATIONS LTD.	FCC ID:	EW780-6101-00	IC ID:	1135A-80610100	
Model(s):	LS5145 / LS5105	Portable 5.8 GHz Cordless Telephone Handset	Freq.:	5744 - 5825 MHz		
2007 Celltech Labs Inc.		This document is not to be reproduced in whole or in part without the prior written permission of Celltech Labs Inc.				Page 43 of 49

HEAD SAR TEST SETUP PHOTOGRAPHS
Left Head Section / Ear-Tilt Position (15°)

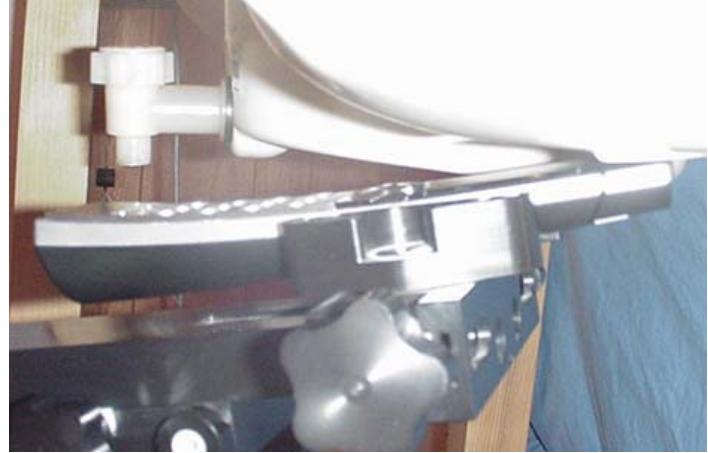

	<u>Date(s) of Evaluation</u> July 13 & 16, 2007	<u>Test Report Serial No.</u> 062107EW7-T839-S15T	<u>Report Revision No.</u> Revision 1.0	 Certificate No. 2470.01
	<u>Test Report Issue Date</u> July 20, 2007	<u>Description of Test(s)</u> Specific Absorption Rate	<u>RF Exposure Category</u> General Population	

DUT PHOTOGRAPHS



Front of DUT



Back of DUT



Top end of DUT



Bottom end of DUT

Company:	VTECH TELECOMMUNICATIONS LTD.	FCC ID:	EW780-6101-00	IC ID:	1135A-80610100	
Model(s):	LS5145 / LS5105	Portable 5.8 GHz Cordless Telephone Handset		Freq.:	5744 - 5825 MHz	
2007 Celltech Labs Inc.		This document is not to be reproduced in whole or in part without the prior written permission of Celltech Labs Inc.				Page 45 of 49

	<u>Date(s) of Evaluation</u> July 13 & 16, 2007	<u>Test Report Serial No.</u> 062107EW7-T839-S15T	<u>Report Revision No.</u> Revision 1.0	  Certificate No. 2470.01
	<u>Test Report Issue Date</u> July 20, 2007	<u>Description of Test(s)</u> Specific Absorption Rate	<u>RF Exposure Category</u> General Population	

DUT PHOTOGRAPHS



Left Side of DUT



Right Side of DUT



DUT Battery Compartment

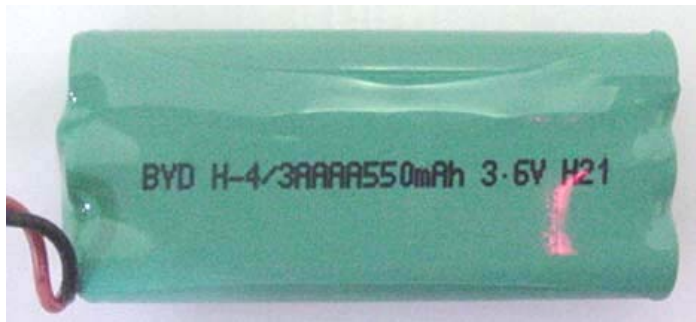

Ni-MH Battery 3.6V, 550mAh

Company:	VTECH TELECOMMUNICATIONS LTD.	FCC ID:	EW780-6101-00	IC ID:	1135A-80610100	
Model(s):	LS5145 / LS5105	Portable 5.8 GHz Cordless Telephone Handset		Freq.:	5744 - 5825 MHz	
2007 Celltech Labs Inc.		This document is not to be reproduced in whole or in part without the prior written permission of Celltech Labs Inc.				Page 46 of 49

	<u>Date(s) of Evaluation</u> July 13 & 16, 2007	<u>Test Report Serial No.</u> 062107EW7-T839-S15T	<u>Report Revision No.</u> Revision 1.0	 Certificate No. 2470.01
	<u>Test Report Issue Date</u> July 20, 2007	<u>Description of Test(s)</u> Specific Absorption Rate	<u>RF Exposure Category</u> General Population	

APPENDIX F - SYSTEM VALIDATION

Company:	VTECH TELECOMMUNICATIONS LTD.	FCC ID:	EW780-6101-00	IC ID:	1135A-80610100	
Model(s):	LS5145 / LS5105	Portable 5.8 GHz Cordless Telephone Handset		Freq.:	5744 - 5825 MHz	
2007 Celltech Labs Inc.		This document is not to be reproduced in whole or in part without the prior written permission of Celltech Labs Inc.				Page 47 of 49

	Date of Evaluation:	May 09, 2007	Document Serial No.:	SV5800B-050907-R1.0	
	Evaluation Type:	System Validation	Validation Dipole:	5800 MHz	Fluid Type:

5800 MHz SYSTEM VALIDATION

Type: **5800 MHz Validation Dipole**

Asset Number: **00126**

Serial Number: **1031**

Place of Validation: **Celltech Labs Inc.**

Date of Validation: **May 09, 2007**

Celltech Labs Inc. certifies that the 5800 MHz System Validation was performed on the date indicated above.

Performed by: **Cheri Frangiadakis**

Approved by: **Jon Hughes**

1. Dipole Construction & Electrical Characteristics

The validation dipole was manufactured by Schmid and Partner Engineering AG. The electrical properties were measured using an HP 8753ET Network Analyzer. The network analyzer was calibrated to the validation dipole N-type connector feed point using an HP85032E Type N calibration kit. The dipole was placed parallel to a planar phantom at a separation distance of 10.0mm from the simulating fluid using a loss-less dielectric spacer. The measured input impedance is:

Feed point impedance at 5800 MHz $\text{Re}\{Z\} = 58.436\Omega$
 $\text{Im}\{Z\} = 5.3613\Omega$

Return Loss at 5800 MHz -21.264 dB

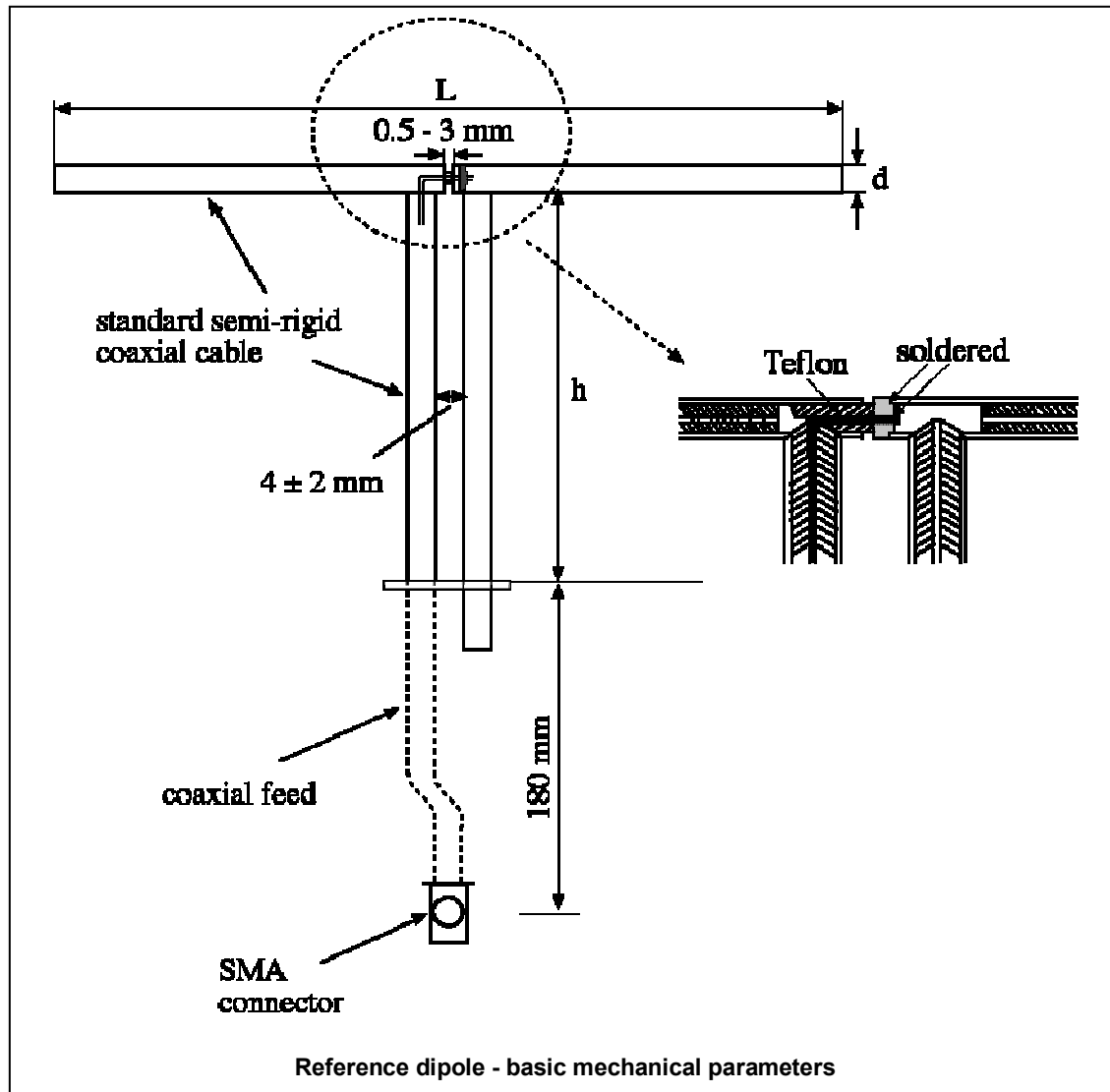

2. Validation Dipole VSWR Data

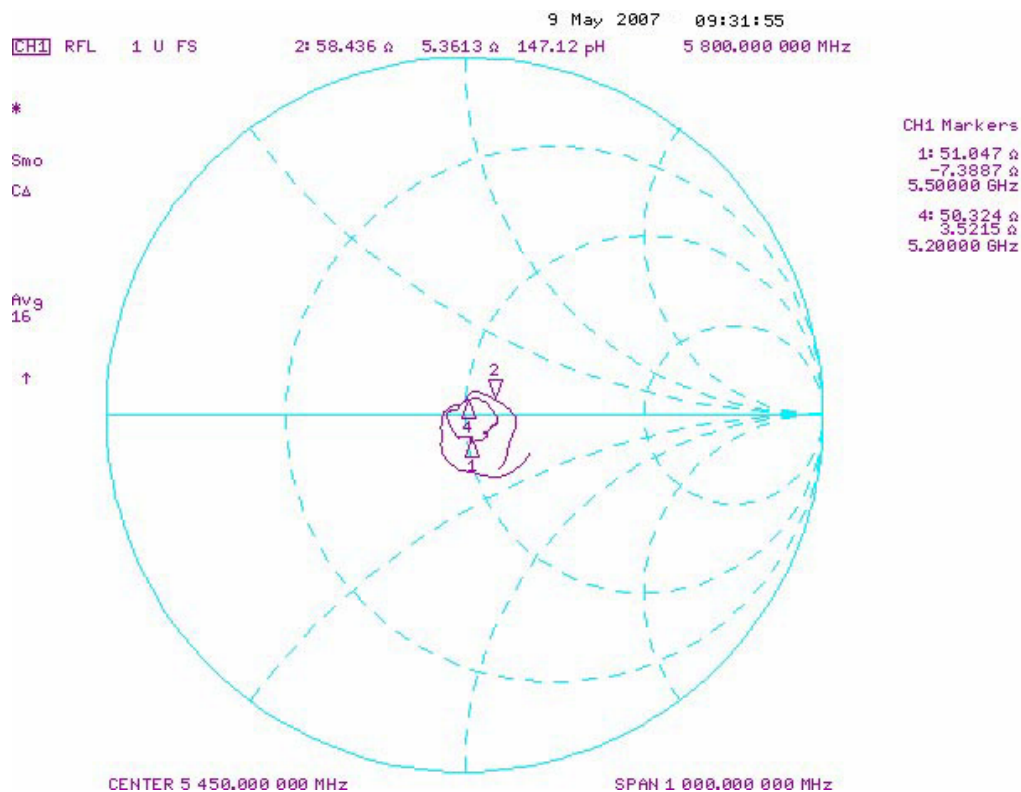
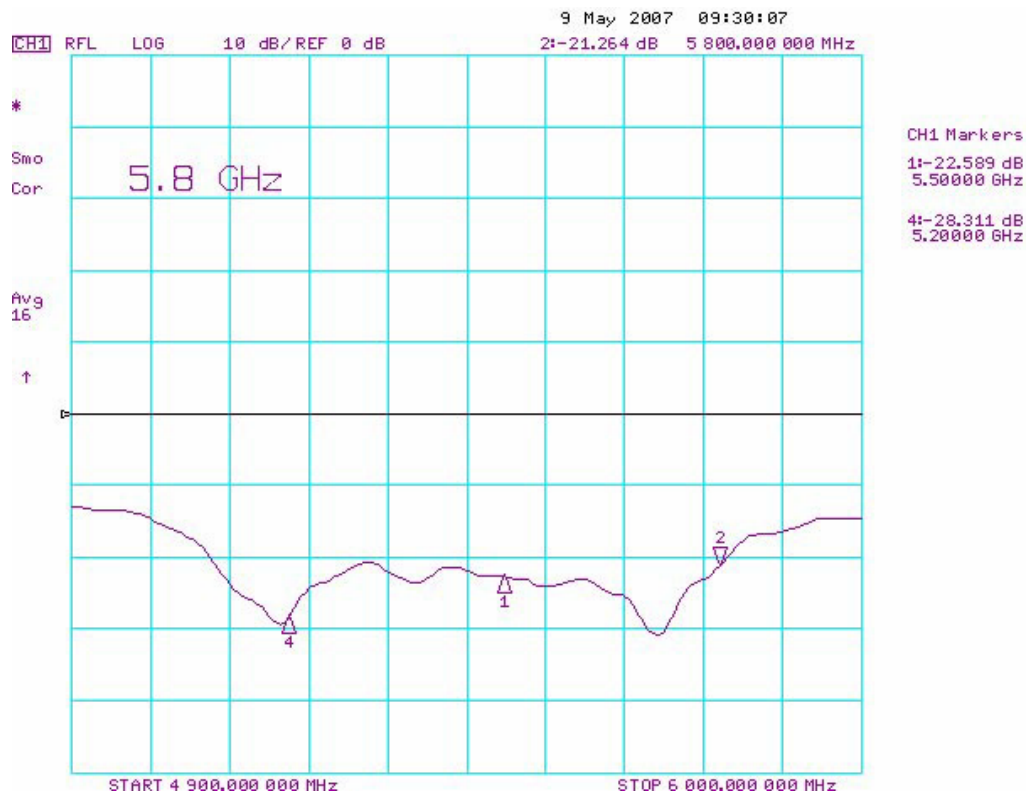

3. Validation Dipole Dimensions

Frequency (MHz)	L (mm)	H (mm)	D (mm)
300	396.0	250.0	6.0
450	270.0	167.0	6.0
835	161.0	89.8	3.6
900	149.0	83.3	3.6
1450	89.1	51.7	3.6
1800	72.0	41.7	3.6
1900	68.0	39.5	3.6
2000	64.5	37.5	3.6
2450	51.5	30.4	3.6
3000	41.5	25.0	3.6
5200 - 5800	20.6	40.65	3.6

4. Validation Phantom

The validation phantom is the SAM (Specific Anthropomorphic Mannequin) phantom manufactured by Schmid & Partner Engineering AG. The SAM phantom is a Fiberglass shell integrated in a wooden table. The shape of the shell corresponds to the phantom defined by SCC34-SC2. It enables the dosimetric evaluation of left and right hand phone usage as well as body mounted usage at the flat phantom region. A cover prevents evaporation of the liquid. Reference markings on the phantom allow the complete setup of all predefined phantom positions and measurement grids by manually teaching three points in the robot.

Shell Thickness: 2.0 ± 0.1 mm
Filling Volume: Approx. 25 liters
Dimensions: 50 cm (W) x 100 cm (L)

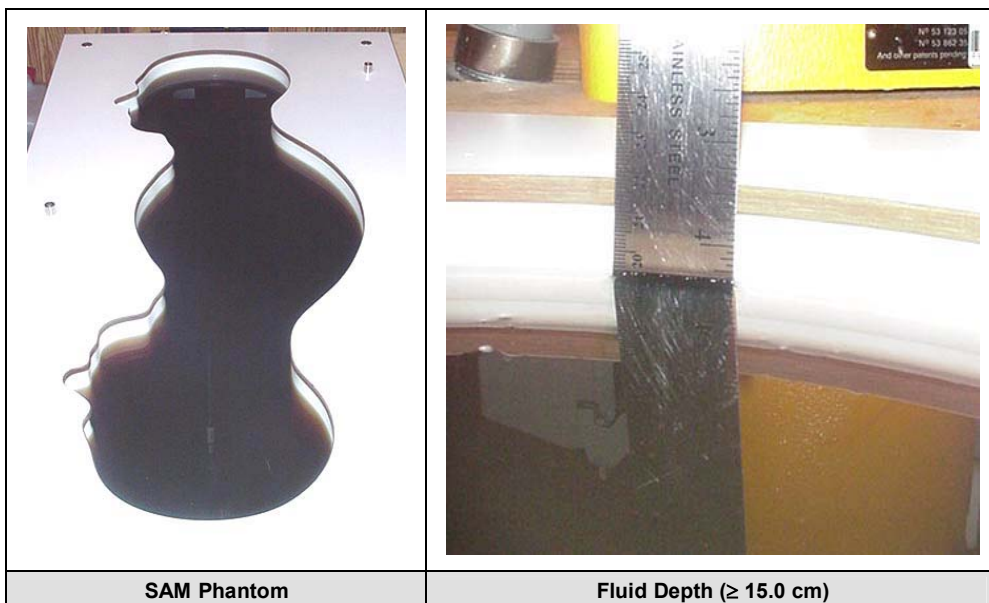

	Date of Evaluation:	May 09, 2007	Document Serial No.:	SV5800B-050907-R1.0	
	Evaluation Type:	System Validation	Validation Dipole:	5800 MHz	Fluid Type:

5. 5800 MHz System Validation Setup



	Date of Evaluation:	May 09, 2007	Document Serial No.:	SV5800B-050907-R1.0		
	Evaluation Type:	System Validation	Validation Dipole:	5800 MHz	Fluid Type:	Brain

6. 5800 MHz Dipole Setup



7. SAR Measurement

Measurements were made using a dosimetric E-field probe EX3DV4 (S/N: 3600, Conversion Factor 4.34). The SAR measurement was performed with the E-field probe in mechanical detection mode only. The setup and determination of the forward power into the dipole was performed using the procedures described below.

First the power meter PM1 (including attenuator Att1) is connected to the cable to measure the forward power at the location of the dipole connector (X). The signal generator is adjusted for the desired forward power at the dipole connector (taking into account the attenuation of Att1) as read by power meter PM2. After connecting the cable to the dipole, the signal generator is readjusted for the same reading at power meter PM2. If the signal generator does not allow adjustment in 0.01dB steps, the remaining difference at PM2 must be taken into consideration. PM3 records the reflected power from the dipole to ensure that the value is not changed from the previous value. The reflected power should be 20dB below the forward power.

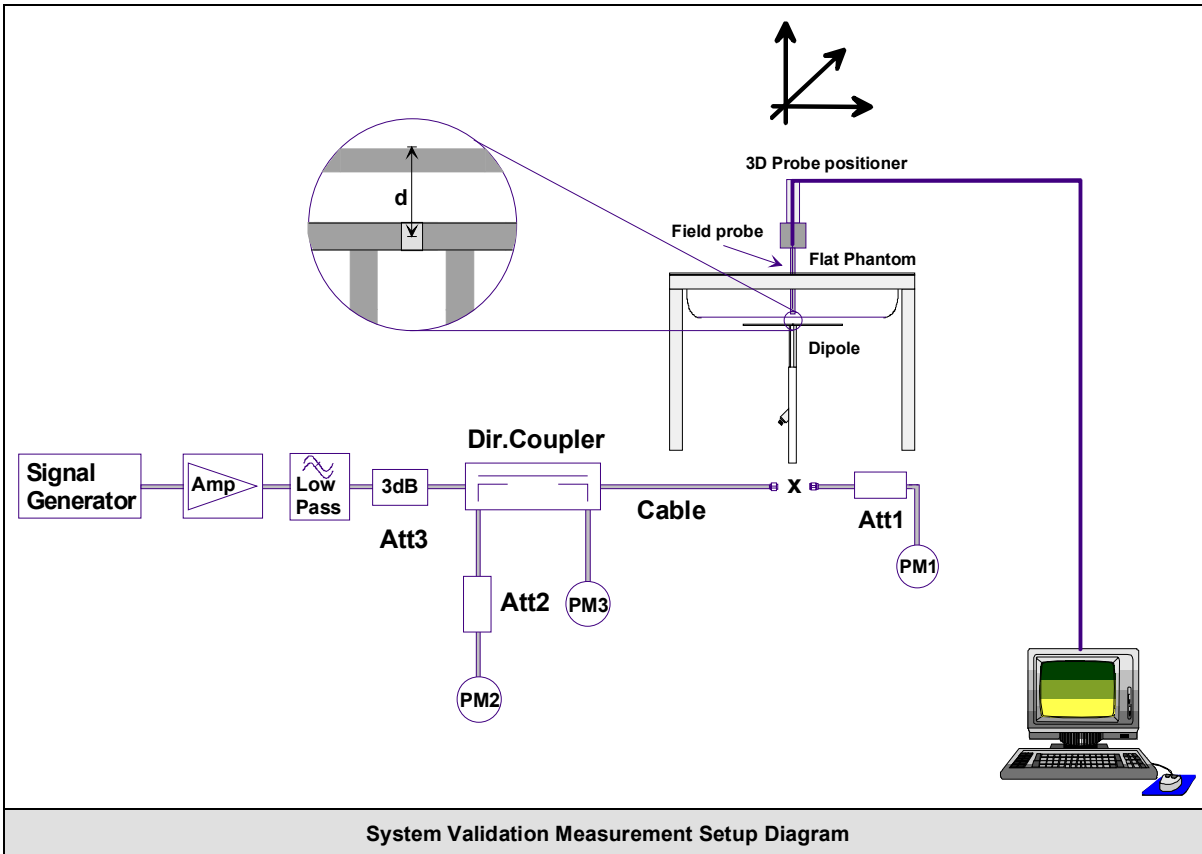

8. Measurement Conditions

The SAM phantom was filled with 5800 MHz Brain tissue simulant.

Relative Permittivity: 31.99 (-9.37% deviation from target)
 Conductivity: 5.53 mho/m (+1.5% deviation from target)
 Fluid Temperature: 23.8°C (Start of Test) / 23.2°C (End of Test)
 Fluid Depth: ≥ 15.0 cm

Environmental Conditions:

Ambient Temperature: 23.3°C
 Humidity: 44%
 Barometric Pressure: 95.6 kPa

The 5800 MHz Brain tissue simulant consisted of the following ingredients:

Ingredient	Percentage by weight	
Water	64 - 78%	
Mineral Oil	11 - 18%	
Emulsifiers	9 - 15%	
Additives and Salt	2 - 3%	
Target Dielectric Parameters:	$\epsilon_r = 35.3$ (+/-10%)	$\sigma = 5.27$ S/m (+/-5%)

9. System Validation SAR Results

SAR @ 0.25W Input averaged over 1g (W/kg)				SAR @ 1W Input averaged over 1g (W/kg)			
SPEAG Target		Measured	Deviation	SPEAG Target		Measured	Deviation
19.5	+/- 10%	21.4	+9.8%	78.0	+/- 10%	85.6	+9.8%
SAR @ 0.25W Input averaged over 10g (W/kg)				SAR @ 1W Input averaged over 10g (W/kg)			
SPEAG Target		Measured	Deviation	SPEAG Target		Measured	Deviation
5.48	+/- 10%	6.02	+9.85%	21.92	+/- 10%	24.08	+9.85%
Extrapolated Peak SAR	SPEAG Target	85.2	+/- 15%	Measured	97.4	+14.35%	

Reference SAR values

The reference SAR values were calculated using finite-difference time-domain FDTD method (feed-point impedance set to 50 Ω) and the mechanical dimensions of the D5GHzV2 dipole (manufactured by SPEAG).

f (GHz)	Head Tissue			Body Tissue		
	SAR_{1g}	SAR_{10g}	SAR_{peak}	SAR_{1g}	SAR_{10g}	SAR_{peak}
5.0	72.9	20.7	285.6	68.1	19.2	260.3
5.1	74.6	21.1	297.5	78.8	19.6	272.3
5.2	76.5	21.6	310.3	71.8	20.1	284.7
5.5	83.3	23.4	349.4	79.1	22.0	326.3
5.8	78.0	21.9	340.9	74.1	20.5	324.7

Table 27.2: Numerical reference SAR values for D5GHzV2 dipole and flat phantom.

	Date of Evaluation:	May 09, 2007	Document Serial No.:	SV5800B-050907-R1.0	
	Evaluation Type:	System Validation	Validation Dipole:	5800 MHz	Fluid Type:

System Validation - 5800 MHz Dipole - May 9, 2007

DUT: Dipole 5GHz; Type: D5GHzV2; Serial: 1031; Asset: 00126

Ambient Temp: 23.3°C; Fluid Temp: 23.8°C; Barometric Pressure: 95.6 kPa; Humidity: 44%

Communication System: CW

Forward Conducted Power: 250 mW

Frequency: 5800 MHz; Duty Cycle: 1:1

Medium: HSL5200-5800 Medium parameters used: $f = 5800$ MHz; $\sigma = 5.53$ mho/m; $\epsilon_r = 31.99$; $\rho = 1000$ kg/m³

- Probe: EX3DV4 - SN3600; ConvF(4.34, 4.34, 4.34); Calibrated: 24/01/2007
- Sensor-Surface: 2mm (Mechanical Surface Detection)
- Electronics: DAE4 Sn353; Calibrated: 21/06/2006
- Phantom: SAM 4.0; Type: Fibreglas; Serial: 1033
- Measurement SW: DASY4, V4.7 Build 44; Postprocessing SW: SEMCAD, V1.8 Build 171

5800 MHz System Validation/Area Scan (9x13x1):

Measurement grid: dx=5mm, dy=5mm

Maximum value of SAR (measured) = 42.5 mW/g

5800 MHz System Validation/Zoom Scan (7x7x9)/Cube 0:

Measurement grid: dx=4mm, dy=4mm, dz=2.5mm

Reference Value = 94.1 V/m; Power Drift = -0.088 dB

Peak SAR (extrapolated) = 97.4 W/kg

SAR(1 g) = 21.4 mW/g; SAR(10 g) = 6.02 mW/g

Maximum value of SAR (measured) = 47.1 mW/g

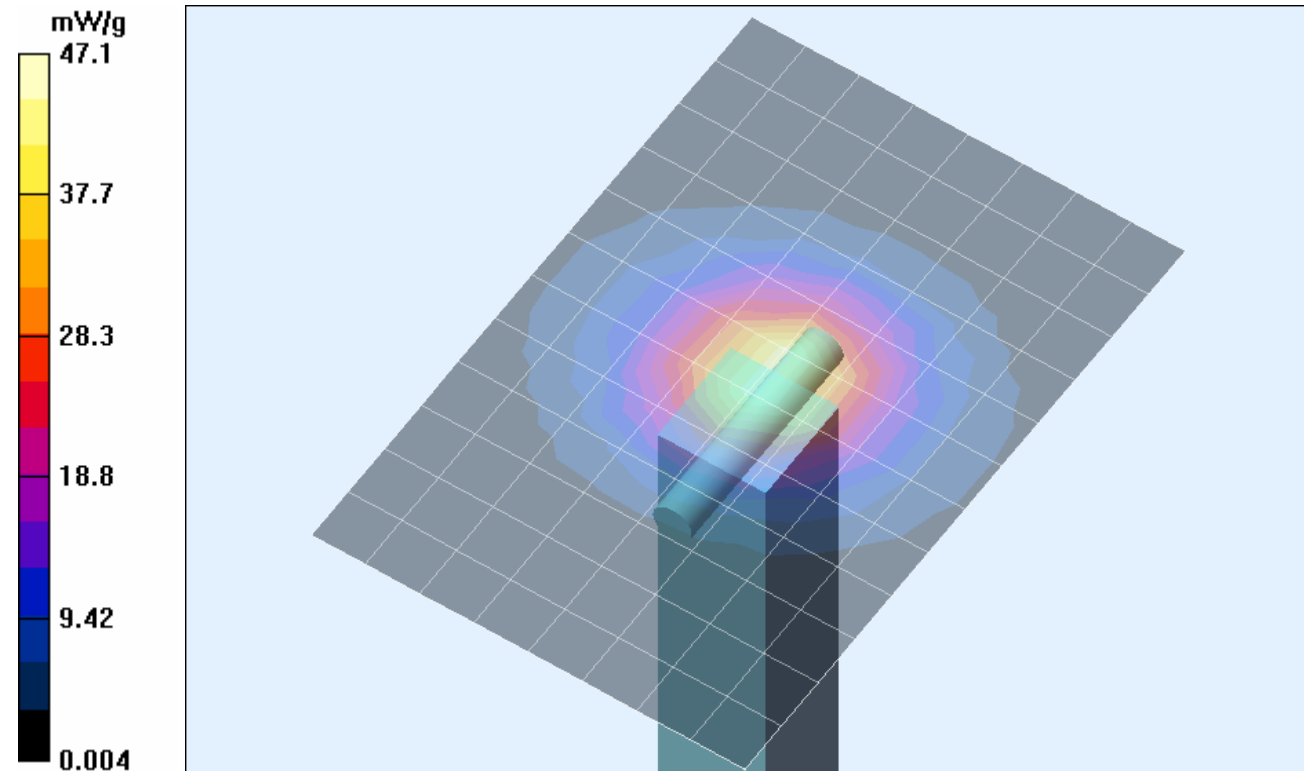

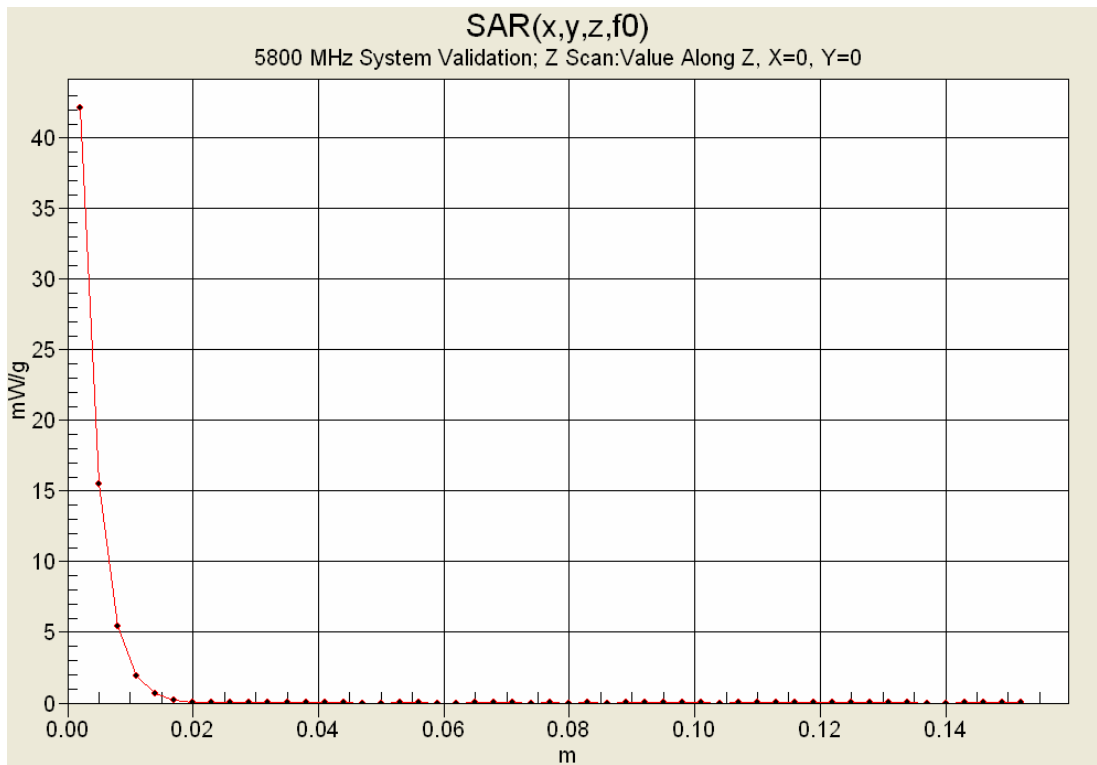

10. Measured Fluid Dielectric Parameters

System Validation - 5800 MHz (Brain)

Celltech Labs Inc.

Test Result for UIM Dielectric Parameter

Tue 09/May/2007

Frequency (GHz)

FCC_eHFCC OET 65 Supplement C (June 2001) Limits for Head Epsilon

FCC_sHFCC OET 65 Supplement C (June 2001) Limits for Head Sigma

Test_e Epsilon of UIM

Test_s Sigma of UIM

Freq	FCC_eHFCC_e	FCC_sHFCC_s	Test_e	Test_s
5.7000	35.41	5.17	32.17	5.39
5.7100	35.40	5.18	32.17	5.48
5.7200	35.39	5.19	32.36	5.50
5.7300	35.38	5.20	32.58	5.43
5.7400	35.37	5.21	32.57	5.39
5.7500	35.36	5.22	32.52	5.38
5.7600	35.35	5.23	32.35	5.31
5.7700	35.33	5.24	32.18	5.36
5.7800	35.32	5.25	32.09	5.40
5.7900	35.31	5.26	31.89	5.46
5.8000	35.30	5.27	31.99	5.53
5.8100	35.29	5.28	32.09	5.57
5.8200	35.28	5.29	32.25	5.60
5.8300	35.27	5.30	32.51	5.57
5.8400	35.25	5.31	32.40	5.55
5.8500	35.24	5.32	32.43	5.51
5.8600	35.23	5.33	32.28	5.46
5.8700	35.22	5.34	32.15	5.49
5.8800	35.21	5.35	32.02	5.52
5.8900	35.20	5.36	31.96	5.57
5.9000	35.19	5.37	31.88	5.65

11. Measurement Uncertainties

UNCERTAINTY BUDGET FOR SYSTEM VALIDATION						
Error Description	Uncertainty Value ±%	Probability Distribution	Divisor	ci 1g	Uncertainty Value ±% (1g)	V _i or V _{eff}
Measurement System						
Probe calibration (5 GHz)	6.6	Normal	1	1	6.6	∞
Axial isotropy of the probe	4.7	Rectangular	1.732050808	1	2.7	∞
Spherical isotropy of the probe	9.6	Rectangular	1.732050808	1	5.5	∞
Spatial resolution	0	Rectangular	1.732050808	1	0.0	∞
Boundary effects	2	Rectangular	1.732050808	1	1.2	∞
Probe linearity	4.7	Rectangular	1.732050808	1	2.7	∞
Detection limit	1	Rectangular	1.732050808	1	0.6	∞
Readout electronics	0.3	Normal	1	1	0.3	∞
Response time	0	Rectangular	1.732050808	1	0.0	∞
Integration time	0	Rectangular	1.732050808	1	0.0	∞
RF ambient conditions	3	Rectangular	1.732050808	1	1.7	∞
Mech. constraints of robot	0.8	Rectangular	1.732050808	1	0.5	∞
Probe positioning	5.7	Rectangular	1.732050808	1	3.3	∞
Extrapolation & integration	4	Rectangular	1.732050808	1	2.3	∞
Dipole						
Dipole positioning	2	Rectangular	1.732050808	1	1.2	∞
Power & Power Drift	4.7	Rectangular	1.732050808	1	2.7	∞
Phantom and Setup						
Phantom uncertainty	4	Rectangular	1.732050808	1	2.3	∞
Liquid conductivity (target)	5	Rectangular	1.732050808	0.64	1.8	∞
Liquid conductivity (measured)	5	Normal	1	0.64	3.2	∞
Liquid permittivity (target)	10	Rectangular	1.732050808	0.6	3.5	∞
Liquid permittivity (measured)	5	Normal	1	0.6	3.0	∞
Combined Standard Uncertainty					12.58	
Expanded Uncertainty (k=2)					25.15	
Note(s)	1. Measurement Uncertainty Table in accordance with IEEE 1528-2003 and IEC 62209-1:2005.					

12. Test Equipment List

TEST EQUIPMENT	ASSET NO.	SERIAL NO.	DATE OF CAL.	CAL. DUE DATE
SPEAG DASY4 Measurement Server	00158	1078	N/A	N/A
SPEAG Robot	00046	599396-01	N/A	N/A
SPEAG DAE4	00019	353	21Jun06	21Jun07
SPEAG EX3DV4 E-Field Probe	00213	3600	24Jan07	24Jan08
SPEAG 5GHz Validation Dipole	00126	1031	09May07	09May08
SPEAG SAM Phantom V4.0C	00154	1033	N/A	N/A
ALS-PR-DIEL Dielectric Probe Kit	00160	260-00953	N/A	N/A
Gigatronics 8652A Power Meter	00007	1835272	26Mar07	26Mar08
Gigatronics 80701A Power Sensor	00014	1833699	22Jan07	22Jan08
Gigatronics 80701A Power Sensor	00109	1834366	26Mar07	26Mar08
HP 8753ET Network Analyzer	00134	US39170292	20Apr07	20Apr08
Rohde & Schwarz SMR20 Signal Generator	00006	100104	NCR	NCR

	<u>Date(s) of Evaluation</u> July 13 & 16, 2007	<u>Test Report Serial No.</u> 062107EW7-T839-S15T	<u>Report Revision No.</u> Revision 1.0	 Certificate No. 2470.01
	<u>Test Report Issue Date</u> July 20, 2007	<u>Description of Test(s)</u> Specific Absorption Rate	<u>RF Exposure Category</u> General Population	

APPENDIX G - PROBE CALIBRATION

Company:	VTECH TELECOMMUNICATIONS LTD.	FCC ID:	EW780-6101-00	IC ID:	1135A-80610100	
Model(s):	LS5145 / LS5105	Portable 5.8 GHz Cordless Telephone Handset		Freq.:	5744 - 5825 MHz	
2007 Celltech Labs Inc.		This document is not to be reproduced in whole or in part without the prior written permission of Celltech Labs Inc.				Page 48 of 49



Accredited by the Swiss Federal Office of Metrology and Accreditation
The Swiss Accreditation Service is one of the signatories to the EA
Multilateral Agreement for the recognition of calibration certificates

Accreditation No.: **SCS 108**

Client **Celltech**

Certificate No: **EX3-3600_Jan07**

CALIBRATION CERTIFICATE

Object: **EX3DV4 - SN:3600**

Calibration procedure(s): **QA CAL-01.v5 and QA CAL-14.v3
Calibration procedure for dosimetric E-field probes**

Calibration date: **January 24, 2007**

Condition of the calibrated item: **In Tolerance**

This calibration certificate documents the traceability to national standards, which realize the physical units of measurements (SI).
The measurements and the uncertainties with confidence probability are given on the following pages and are part of the certificate.

All calibrations have been conducted in the closed laboratory facility: environment temperature (22 ± 3)°C and humidity < 70%.

Calibration Equipment used (M&TE critical for calibration)

Primary Standards	ID #	Cal Date (Calibrated by, Certificate No.)	Scheduled Calibration
Power meter E4419B	GB41293874	5-Apr-06 (METAS, No. 251-00557)	Apr-07
Power sensor E4412A	MY41495277	5-Apr-06 (METAS, No. 251-00557)	Apr-07
Power sensor E4412A	MY41498087	5-Apr-06 (METAS, No. 251-00557)	Apr-07
Reference 3 dB Attenuator	SN: S5054 (3c)	10-Aug-06 (METAS, No. 217-00592)	Aug-07
Reference 20 dB Attenuator	SN: S5086 (20b)	4-Apr-06 (METAS, No. 251-00558)	Apr-07
Reference 30 dB Attenuator	SN: S5129 (30b)	10-Aug-06 (METAS, No. 217-00593)	Aug-07
Reference Probe ES3DV2	SN: 3013	4-Jan-07 (SPEAG, No. ES3-3013_Jan07)	Jan-08
DAE4	SN: 654	21-Jun-06 (SPEAG, No. DAE4-654_Jun06)	Jun-07
Secondary Standards	ID #	Check Date (in house)	Scheduled Check
RF generator HP 8648C	US3642U01700	4-Aug-99 (SPEAG, in house check Nov-05)	In house check: Nov-07
Network Analyzer HP 8753E	US37390585	18-Oct-01 (SPEAG, in house check Oct-06)	In house check: Oct-07

Calibrated by: **Katja Pokovic** (Name), **Technical Manager** (Function), *[Signature]* (Signature)

Approved by: **Niels Kuster** (Name), **Quality Manager** (Function), *[Signature]* (Signature)

Issued: January 24, 2007

This calibration certificate shall not be reproduced except in full without written approval of the laboratory.



Accredited by the Swiss Federal Office of Metrology and Accreditation
The Swiss Accreditation Service is one of the signatories to the EA
Multilateral Agreement for the recognition of calibration certificates

Accreditation No.: **SCS 108**

Glossary:

TSL	tissue simulating liquid
NORM _{x,y,z}	sensitivity in free space
ConF	sensitivity in TSL / NORM _{x,y,z}
DCP	diode compression point
Polarization φ	φ rotation around probe axis
Polarization ϑ	ϑ rotation around an axis that is in the plane normal to probe axis (at measurement center), i.e., $\vartheta = 0$ is normal to probe axis

Calibration is Performed According to the Following Standards:

- IEEE Std 1528-2003, "IEEE Recommended Practice for Determining the Peak Spatial-Averaged Specific Absorption Rate (SAR) in the Human Head from Wireless Communications Devices: Measurement Techniques", December 2003
- CENELEC EN 50361, "Basic standard for the measurement of Specific Absorption Rate related to human exposure to electromagnetic fields from mobile phones (300 MHz - 3 GHz), July 2001

Methods Applied and Interpretation of Parameters:

- NORM_{x,y,z}**: Assessed for E-field polarization $\vartheta = 0$ ($f \leq 900$ MHz in TEM-cell; $f > 1800$ MHz: R22 waveguide). NORM_{x,y,z} are only intermediate values, i.e., the uncertainties of NORM_{x,y,z} does not effect the E²-field uncertainty inside TSL (see below *ConvF*).
- NORM(f)_{x,y,z} = NORM_{x,y,z} * frequency_response** (see Frequency Response Chart). This linearization is implemented in DASY4 software versions later than 4.2. The uncertainty of the frequency response is included in the stated uncertainty of *ConvF*.
- DCP_{x,y,z}**: DCP are numerical linearization parameters assessed based on the data of power sweep (no uncertainty required). DCP does not depend on frequency nor media.
- ConvF and Boundary Effect Parameters**: Assessed in flat phantom using E-field (or Temperature Transfer Standard for $f \leq 800$ MHz) and inside waveguide using analytical field distributions based on power measurements for $f > 800$ MHz. The same setups are used for assessment of the parameters applied for boundary compensation (alpha, depth) of which typical uncertainty values are given. These parameters are used in DASY4 software to improve probe accuracy close to the boundary. The sensitivity in TSL corresponds to NORM_{x,y,z} * *ConvF* whereby the uncertainty corresponds to that given for *ConvF*. A frequency dependent *ConvF* is used in DASY version 4.4 and higher which allows extending the validity from ± 50 MHz to ± 100 MHz.
- Spherical isotropy (3D deviation from isotropy)**: in a field of low gradients realized using a flat phantom exposed by a patch antenna.
- Sensor Offset**: The sensor offset corresponds to the offset of virtual measurement center from the probe tip (on probe axis). No tolerance required.

Probe EX3DV4

SN:3600

Manufactured: January 10, 2007
Calibrated: January 24, 2007

Calibrated for DASY Systems

(Note: non-compatible with DASY2 system!)

Frequency Response of E-Field

(TEM-Cell:ifi110 EXX, Waveguide: R22)

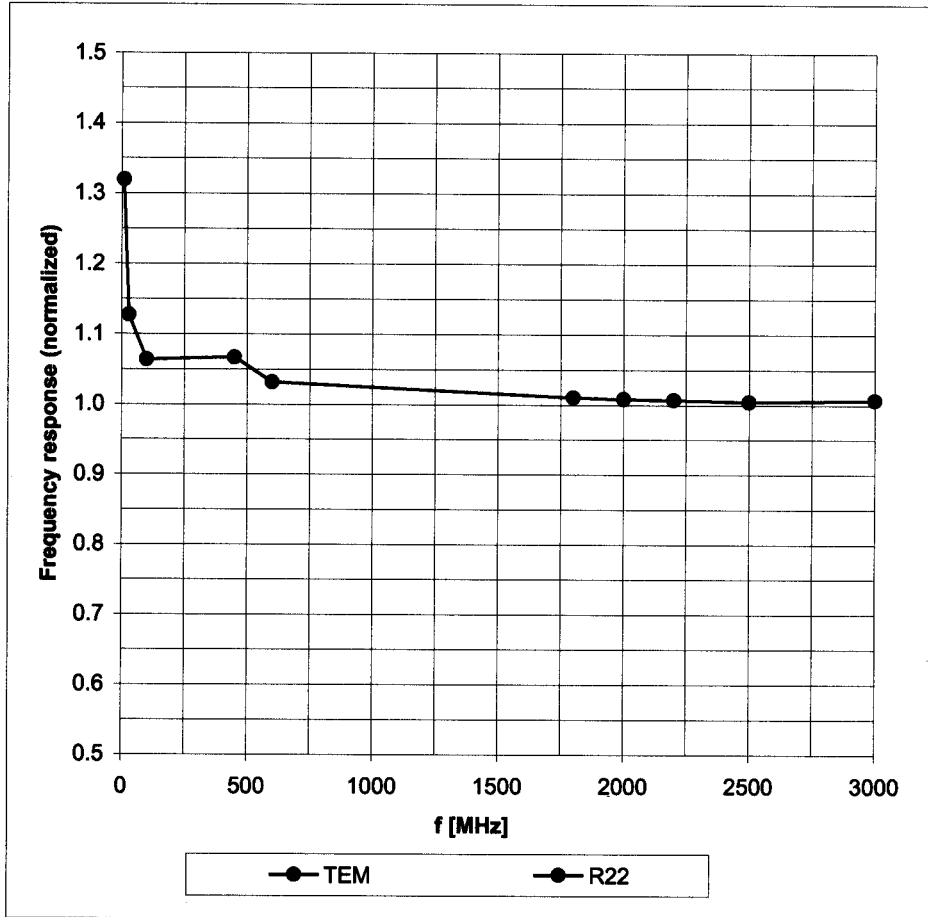

Uncertainty of Frequency Response of E-field: $\pm 6.3\%$ ($k=2$)

Receiving Pattern (ϕ), $\vartheta = 0^\circ$

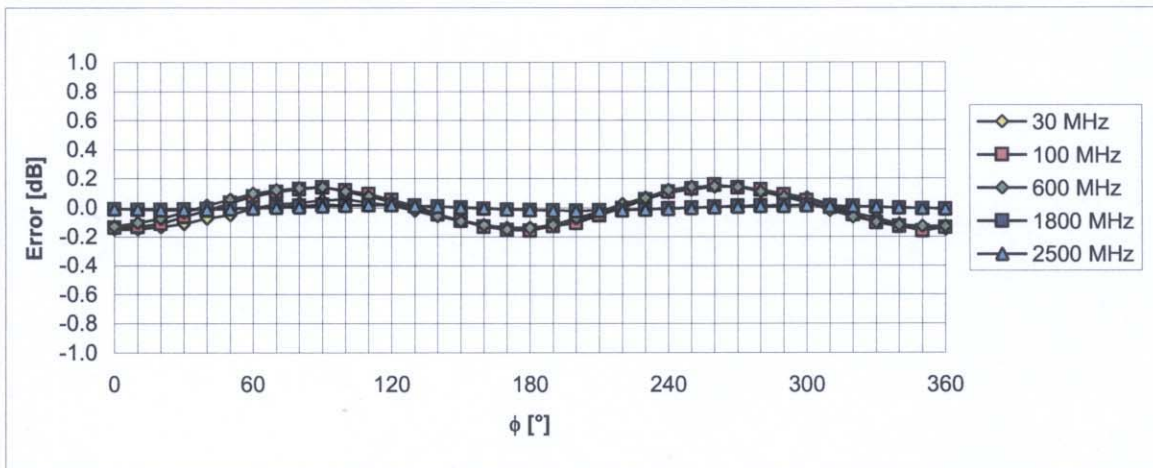
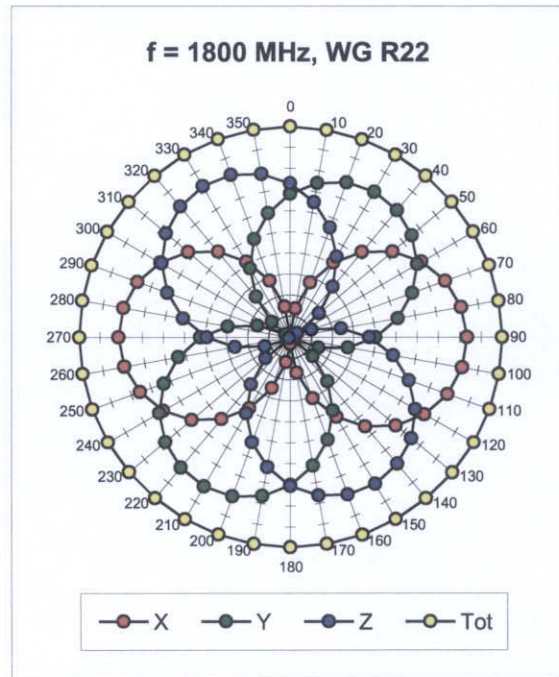
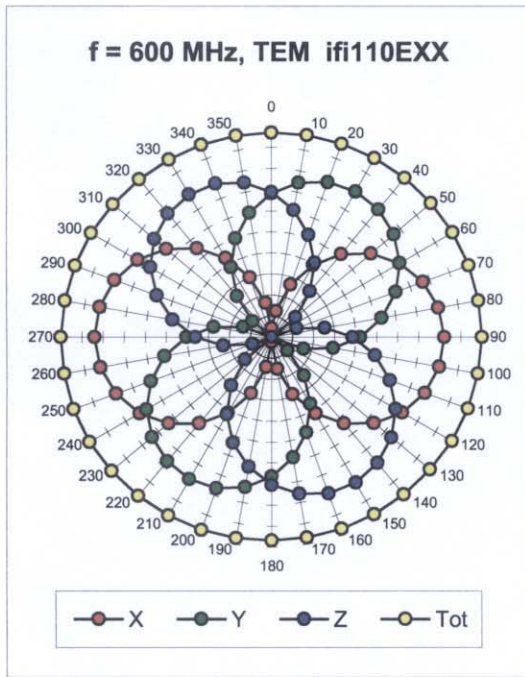

Uncertainty of Axial Isotropy Assessment: $\pm 0.5\%$ ($k=2$)

Dynamic Range $f(\text{SAR}_{\text{head}})$

(Waveguide R22, $f = 1800 \text{ MHz}$)

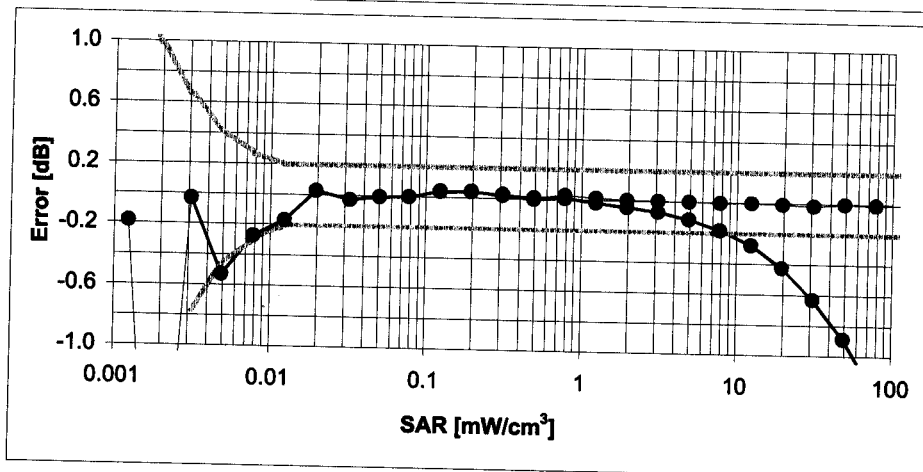
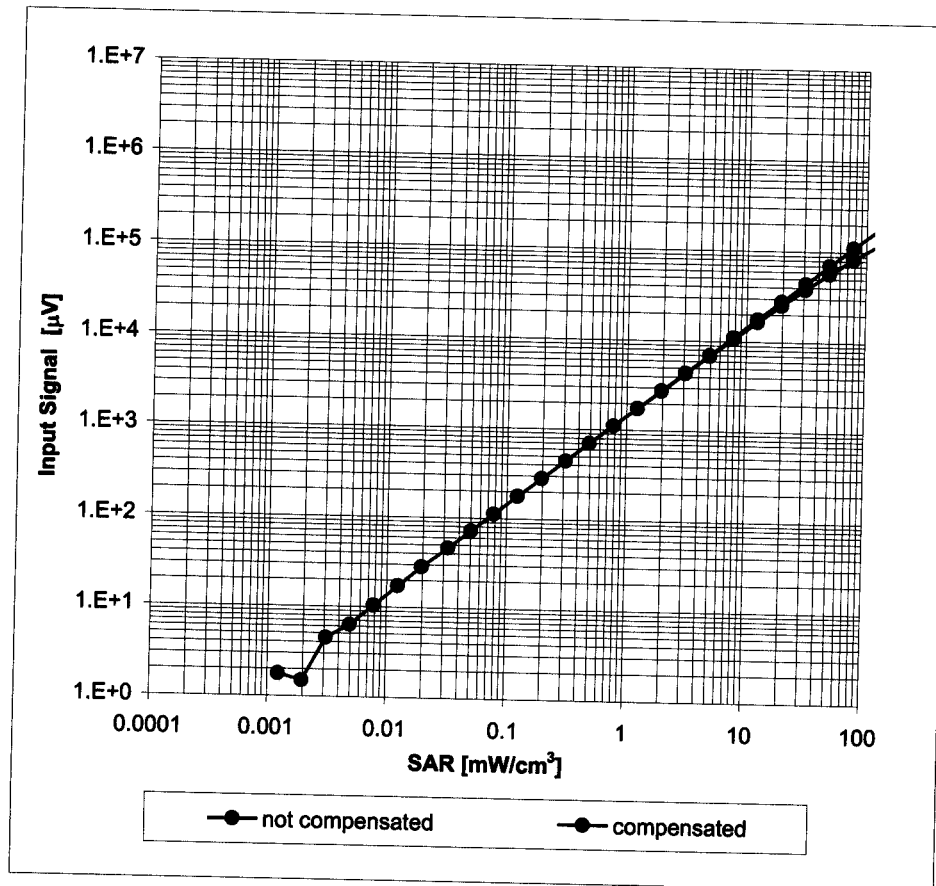

Uncertainty of Linearity Assessment: $\pm 0.6\%$ ($k=2$)

Conversion Factor Assessment

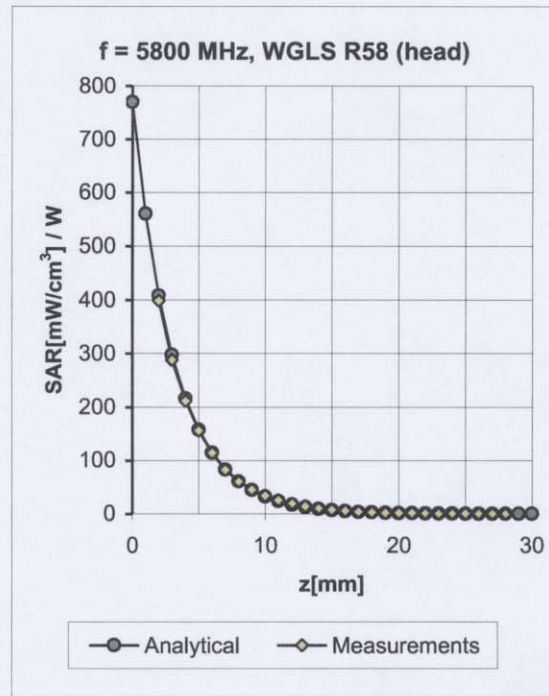
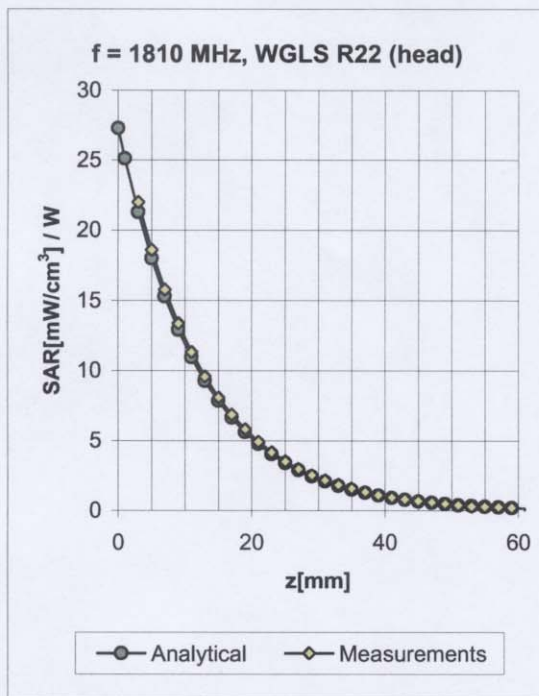

f [MHz]	Validity [MHz] ^c	TSL	Permittivity	Conductivity	Alpha	Depth	ConvF Uncertainty
1810	± 50 / ± 100	Head	40.0 ± 5%	1.40 ± 5%	0.20	1.01	7.02 ± 11.0% (k=2)
1950	± 50 / ± 100	Head	40.0 ± 5%	1.40 ± 5%	0.26	1.05	6.59 ± 11.0% (k=2)
2450	± 50 / ± 100	Head	39.2 ± 5%	1.80 ± 5%	0.44	1.00	6.37 ± 11.8% (k=2)
5800	± 50 / ± 100	Head	35.3 ± 5%	5.27 ± 5%	0.37	1.65	4.34 ± 13.1% (k=2)
1810	± 50 / ± 100	Body	53.3 ± 5%	1.52 ± 5%	0.24	1.06	6.85 ± 11.0% (k=2)
1950	± 50 / ± 100	Body	53.3 ± 5%	1.52 ± 5%	0.16	1.35	6.54 ± 11.0% (k=2)
2450	± 50 / ± 100	Body	52.7 ± 5%	1.95 ± 5%	0.42	1.00	6.31 ± 11.8% (k=2)
5200	± 50 / ± 100	Body	49.0 ± 5%	5.30 ± 5%	0.35	1.70	4.10 ± 13.1% (k=2)
5500	± 50 / ± 100	Body	48.6 ± 5%	5.65 ± 5%	0.32	1.70	3.95 ± 13.1% (k=2)
5800	± 50 / ± 100	Body	48.2 ± 5%	6.00 ± 5%	0.33	1.70	4.14 ± 13.1% (k=2)

^c The validity of ± 100 MHz only applies for DASY v4.4 and higher (see Page 2). The uncertainty is the RSS of the ConvF uncertainty at calibration frequency and the uncertainty for the indicated frequency band.

Deviation from Isotropy in HSL

Error (ϕ, ϑ), $f = 900$ MHz

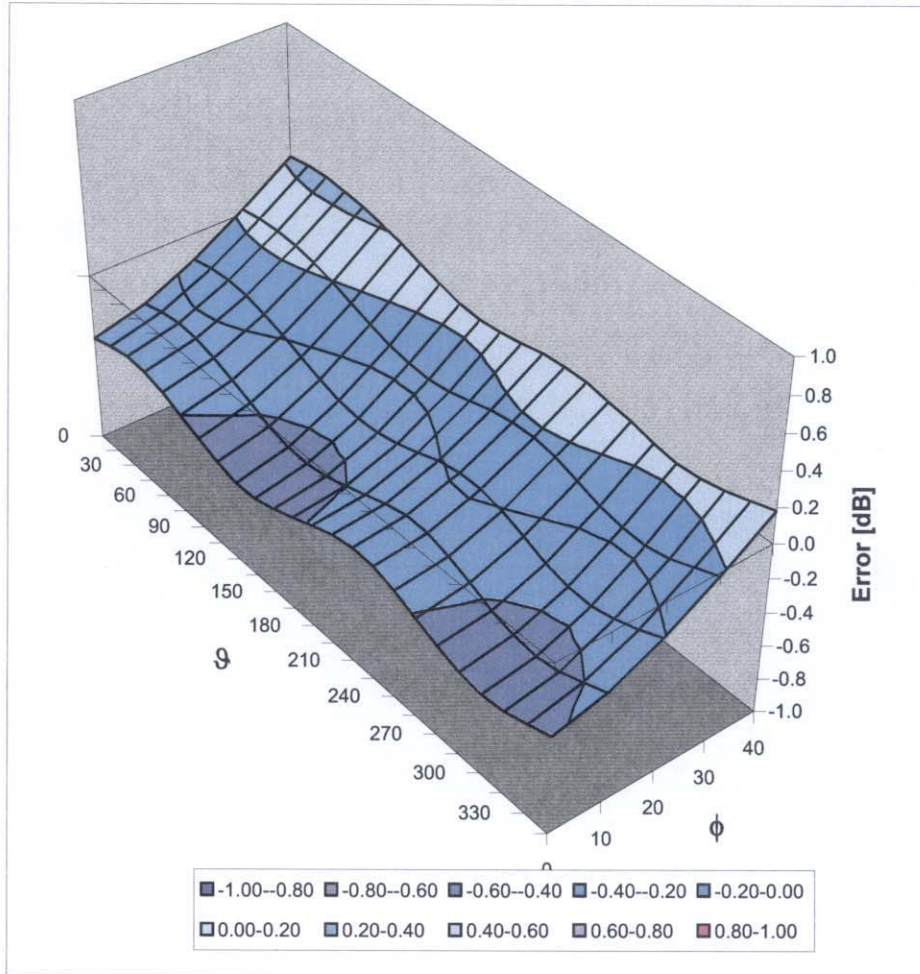

Uncertainty of Spherical Isotropy Assessment: $\pm 2.6\%$ ($k=2$)

	<u>Date(s) of Evaluation</u> July 13 & 16, 2007	<u>Test Report Serial No.</u> 062107EW7-T839-S15T	<u>Report Revision No.</u> Revision 1.0	 Certificate No. 2470.01
	<u>Test Report Issue Date</u> July 20, 2007	<u>Description of Test(s)</u> Specific Absorption Rate	<u>RF Exposure Category</u> General Population	

APPENDIX H - SAM PHANTOM CERTIFICATE OF CONFORMITY

Company:	VTECH TELECOMMUNICATIONS LTD.	FCC ID:	EW780-6101-00	IC ID:	1135A-80610100	
Model(s):	LS5145 / LS5105	Portable 5.8 GHz Cordless Telephone Handset		Freq.:	5744 - 5825 MHz	
2007 Celltech Labs Inc.		This document is not to be reproduced in whole or in part without the prior written permission of Celltech Labs Inc.				Page 49 of 49

Schmid & Partner Engineering AG

Zeughausstrasse 43, 8004 Zurich, Switzerland, Phone +41 1 245 97 00, Fax +41 1 245 97 79

Certificate of conformity / First Article Inspection

Item	SAM Twin Phantom V4.0
Type No	QD 000 P40 BA
Series No	TP-1002 and higher
Manufacturer / Origin	Untersee Composites Hauptstr. 69 CH-8559 Fruthwilen Switzerland

Tests

The series production process used allows the limitation to test of first articles. Complete tests were made on the pre-series Type No. QD 000 P40 AA, Serial No. TP-1001 and on the series first article Type No. QD 000 P40 BA, Serial No. TP-1006. Certain parameters have been retested using further series units (called samples).

Test	Requirement	Details	Units tested
Shape	Compliance with the geometry according to the CAD model.	IT'IS CAD File (*)	First article, Samples
Material thickness	Compliant with the requirements according to the standards	2mm +/- 0.2mm in specific areas	First article, Samples
Material parameters	Dielectric parameters for required frequencies	200 MHz – 3 GHz Relative permittivity < 5 Loss tangent < 0.05.	Material sample TP 104-5
Material resistivity	The material has been tested to be compatible with the liquids defined in the standards	Liquid type HSL 1800 and others according to the standard.	Pre-series, First article

Standards

- [1] CENELEC EN 50361
- [2] IEEE P1528-200x draft 6.5
- [3] IEC PT 62209 draft 0.9

(*) The IT'IS CAD file is derived from [2] and is also within the tolerance requirements of the shapes of [1] and [3].

Conformity

Based on the sample tests above, we certify that this item is in compliance with the uncertainty requirements of SAR measurements specified in standard [1] and draft standards [2] and [3].

Date 18.11.2001

Signature / Stamp

**Schmid & Partner
Engineering AG**

Zeughausstrasse 43, CH-8004 Zurich
Tel. +41 1 245 97 00, Fax +41 1 245 97 79