

# LS5145 Engraving Draft

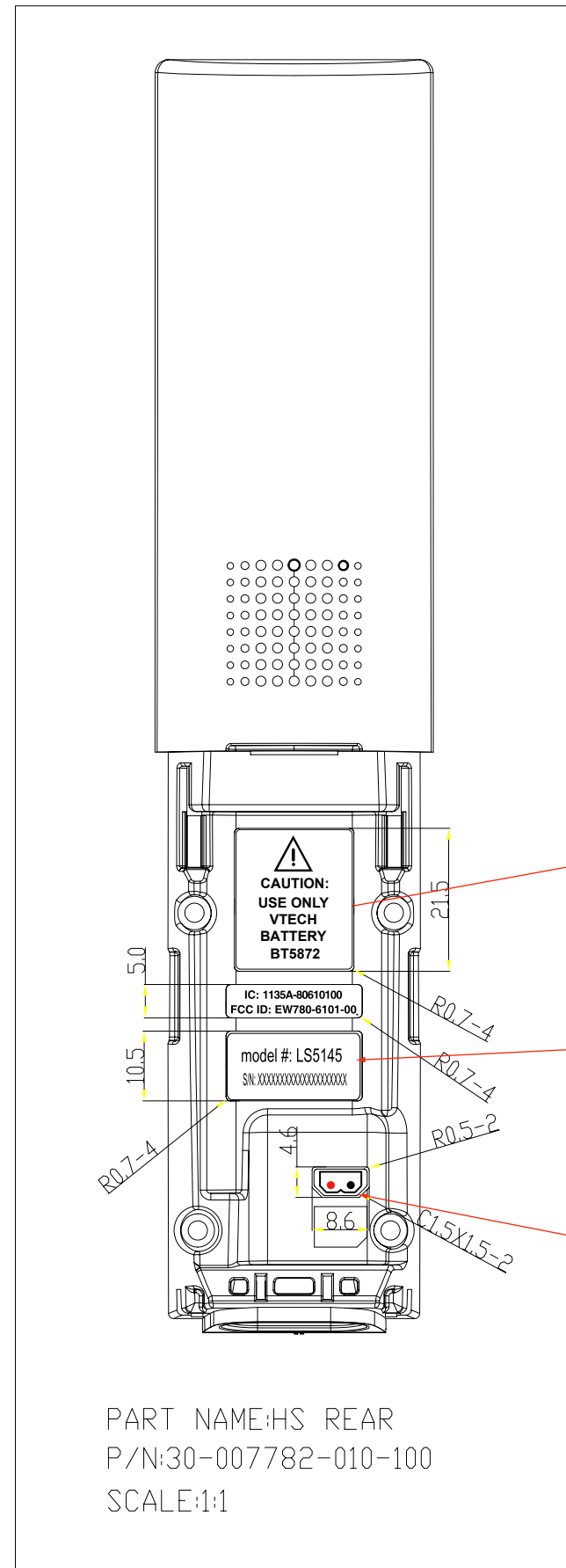

Caution label



SN label

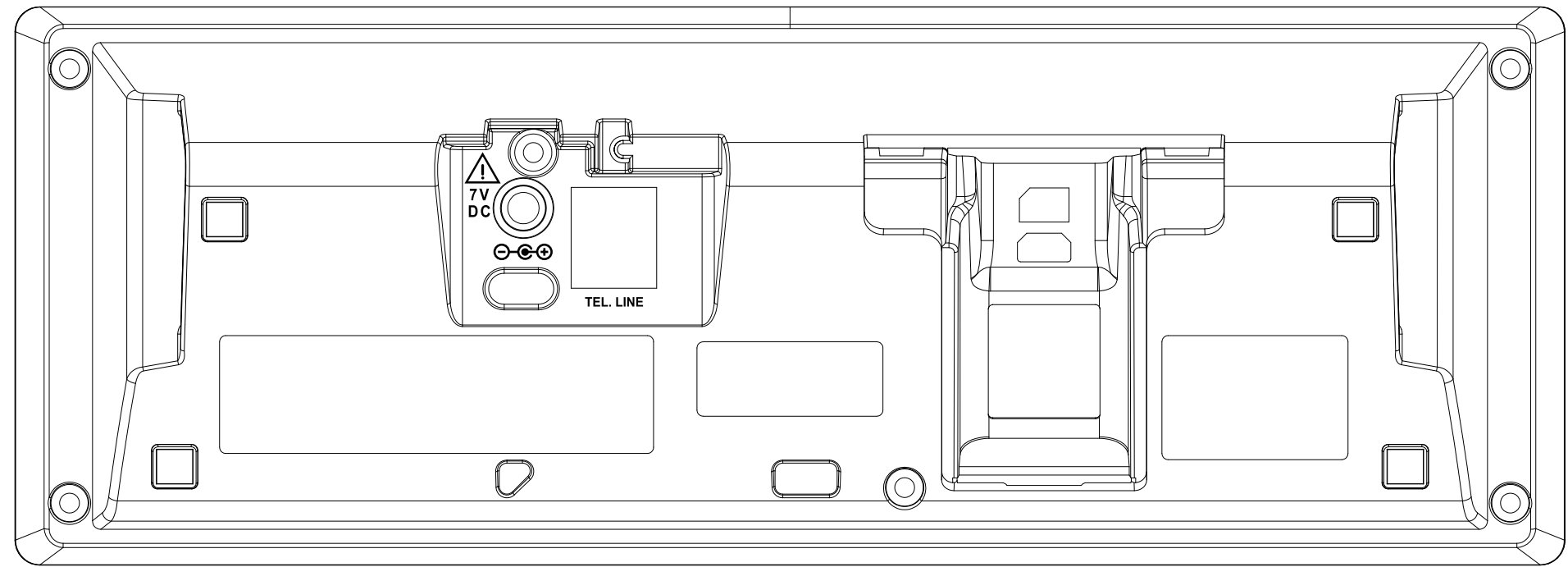
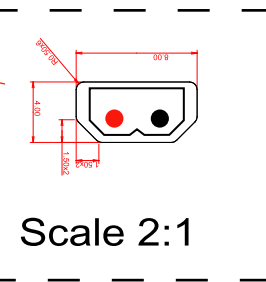
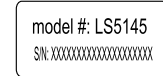

View from power jack plane

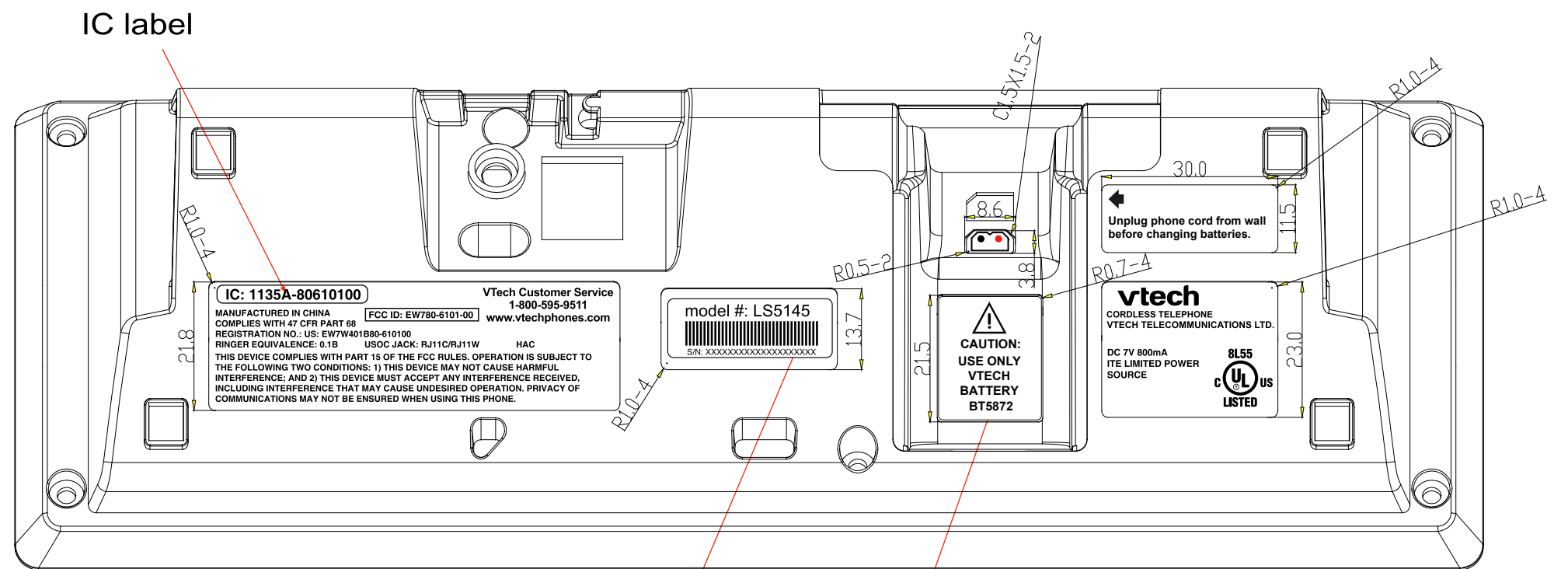

View from desk plane

PART NAME:BS BTM  
P/N: 30-007797-000-100  
SCALE:1:1