

| | |
|-------|---------------------------------------|
| TITLE | PDL GX Internal Product Specification |
| MODEL | PDL GX |

PDL GX

Internal Product Specification

NOT FOR EXTERNAL RELEASE

Document ID: GXSPC3-0.DOC
PRC #: 00DM

Note: All rights reserved. No part of this publication may be reproduced or transmitted in any form or by any means. The only controlled copy of this document is kept in electronic form on the VTECH computer network. All printed copies are uncontrolled documents and are not updated. This Procedure is the property of VTECH Engineering Canada Ltd., and shall be returned upon request

| | |
|-------------|-----------------|
| Prepared By | Gordon Ryley |
| Title | Project Manager |
| Approved By | |
| Title | |

| | |
|--------------|--|
| TITLE | PDL GX Internal Product Specification |
| MODEL | PDL GX |

Revision History

| Revision No | Description | Page | Effective Date |
|--------------------|---|--|-----------------------|
| Preliminary | | | July 21,'98 |
| 1 | First Release | | Aug 14,'98 |
| 2 | Updated Release with UI changes | All | Sept 22, 1998 |
| 2.1 | Incorporated Regulatory Requirements and Page Key operation | 6,37 | 24-SEP-98 |
| 2.2 | Changes to Electrical Specs. Changed title to Internal Product Spec. Added Base LED Operation | All | 22-OCT-98 |
| 2.3 | Revised after TM1 Review Comments. Added Call Forward Display and changes to menu displays | All | 5-NOV-98 |
| 2.4 | Revised Call Forward operation as per Radio Shack req's. Corrected redial examples. Corrected CID Recall Option examples. Revised CLEAR MEMORY menu operation. Defined VMWI as a factory programmable option. Minor corrections to other sections. | pp. 15, 22, 23, 25, 29, 34-38, and 42. | 25-NOV-98 |
| 3.0 | Removed OUT OF AREA message description from CID. Corrected last message for Step 6 on SET RING TYPE description. Corrected Set Ring Volume description Step 6 to say LOW instead of HIGH. Added CID display of telephone numbers section. Added Red/Green or All Red LED Indicator Options | All | 18-JAN-99 |

| | |
|--------------|---------------------------------------|
| TITLE | PDL GX Internal Product Specification |
| MODEL | PDL GX |

Table of Contents

| | | |
|-----------|--|-----------|
| 1. | Overview | 6 |
| 1.1 | General Description..... | 6 |
| 1.2 | Regulatory Standards..... | 6 |
| 1.3 | Feature List | 7 |
| 1.3.1 | Basic Features | 7 |
| 1.3.2 | Unique Features | 7 |
| 1.3.3 | Features Not Provided | 8 |
| 1.4 | Cosmetic Styling..... | 9 |
| 2. | Functional Description | 11 |
| 2.1 | Handset Display and Keypad Layout | 11 |
| 2.2 | Base Key Layout and Indicators..... | 12 |
| 2.3 | Base LED User Interface Status Indicators | 13 |
| 3. | User Interface Specification | 14 |
| 3.1 | User Interface Status Tones | 14 |
| 3.2 | Navigation/Features/Menus | 14 |
| 3.2.1 | On Hook State Menus | 15 |
| 3.2.2 | Off Hook State Menus | 15 |
| 3.2.3 | Mode Timeout | 16 |
| 3.3 | Dial Modes | 17 |
| 3.3.1 | Pre-Seizure (On-Hook) Dialing or Pre-Dial..... | 17 |
| 3.3.1.1 | Pre-Dial Digit Entry and Editing | 17 |
| 3.3.1.2 | Pre-Dial Example | 18 |
| 3.3.2 | Post-Seizure Dialing (Off-Hook) or Live Dial | 19 |
| 3.4 | Using SELECT or PHONE key When Recalling Numbers | 19 |
| 3.4.1 | Pre-Dial Recall Example Using PHONE Key (WYSIWYG)..... | 20 |
| 3.4.2 | Pre-Dial Recall Using SELECT Key..... | 20 |
| 3.4.3 | Live-Dial Recall Using PHONE or SELECT Key..... | 21 |
| 3.5 | Placing A Call on Hold..... | 21 |
| 3.6 | Last Number Redial | 22 |

| | | |
|---------------------|---------------|---------------|
| Reference: PRC 00DM | Revision: 3.0 | Page: 3 of 56 |
|---------------------|---------------|---------------|

| | |
|--------------|--|
| TITLE | PDL GX Internal Product Specification |
| MODEL | PDL GX |

| | | |
|--------------|---|-----------|
| 3.6.1 | Review/Recalling Most Recently Dialed Numbers from Redial Memory | 22 |
| 3.6.1.1 | Redial Example Using PHONE key from Pre-Dial Mode: | 23 |
| 3.6.1.2 | Redial Example Using PHONE key from Live-Dial Mode: | 24 |
| 3.6.2 | Storing Redial Records..... | 24 |
| 3.7 | Incoming Calls | 25 |
| 3.7.1 | Ringng | 25 |
| 3.7.2 | Answering the Incoming Call | 25 |
| 3.7.3 | Terminating the Incoming Call..... | 25 |
| 3.8 | Calling Line ID Functions..... | 26 |
| 3.8.1 | CID Type I | 26 |
| 3.8.2 | Call Forward Indicator..... | 26 |
| 3.8.3 | New Calls Indicator | 27 |
| 3.8.3.1 | New Calls LED Indicator Option..... | 27 |
| 3.8.4 | CID Type II | 27 |
| 3.8.5 | Review/Recall Telephone Numbers from CID Memory..... | 27 |
| 3.8.5.1 | CID Number Recall Options..... | 29 |
| 3.8.6 | Deleting a CID Record in Review Mode..... | 30 |
| 3.8.7 | Call Forward Display of Telephone Numbers..... | 31 |
| 3.9 | Speed Dial Functions | 32 |
| 3.9.1 | Programing Speed Dial Memory..... | 32 |
| 3.9.1.1 | Program Speed Dial Example..... | 32 |
| 3.9.2 | Review/Recall Telephone Number from Speed Dial Memory | 33 |
| 3.9.2.1 | Speed Dial Review Example | 34 |
| 3.9.3 | Deleting a Speed Dial Location in Review Mode..... | 35 |
| 3.10 | Clearing CID, Speed Dial Memory and VMWI | 36 |
| 3.10.1 | Clear Memory Menu Structure If VMWI Is Supported | 36 |
| 3.10.2 | Clear Memory Menu Structure If VMWI Is NOT Supported | 36 |
| 3.10.3 | Clearing The Visual Message Waiting Indicator (If VMWI Option is Supported) | 37 |
| 3.10.4 | Clearing All CID Records | 38 |
| 3.10.5 | Clearing All Speed Dial Locations | 39 |
| 3.11 | Flashing the Line/Switching Over to New Call..... | 40 |
| 3.12 | Visual Message Waiting Indication (VMWI) | 40 |
| 3.12.1 | VMWI LED Display Option | 40 |
| 3.13 | Setup Mode Options | 41 |
| 3.13.1 | Ring Type Setting (4 selection and OFF) | 42 |
| 3.13.2 | Ringer Volume Control (High or Low) | 43 |
| 3.13.3 | Dialing Type Selection (Tone or Pulse)..... | 44 |
| 3.13.4 | Keyclick Selection (On or Off)..... | 45 |
| 3.14 | Page Key Operation..... | 46 |
| 3.15 | In Use/Charging LED Indicator | 46 |
| 3.15.1 | Red/Green LED Option..... | 46 |

| | | |
|----------------------------|----------------------|----------------------|
| Reference: PRC 00DM | Revision: 3.0 | Page: 4 of 56 |
|----------------------------|----------------------|----------------------|

| | |
|--------------|--|
| TITLE | PDL GX Internal Product Specification |
| MODEL | PDL GX |

| | | |
|----------|--|-----------|
| 3.15.1.1 | In Use/Charging LED Display State Priority (Red/Green LEDs)..... | 46 |
| 3.15.2 | All Red LED Option..... | 46 |
| 3.15.2.1 | In Use/Charging LED Display State Priority (All Red LEDs)..... | 47 |
| 3.16 | Temporary Tone Activation..... | 47 |
| 3.17 | Ear Piece Volume Adjustment..... | 47 |
| 3.18 | Spare Battery/POTS mode..... | 48 |
| 3.19 | Low Battery Warning..... | 48 |
| 3.20 | Parallel Set Indication..... | 48 |
| 3.21 | Headset Jack..... | 49 |
| 3.22 | No Telephone Line Connected..... | 49 |
| 3.23 | Display Priority of Non Mode Specific Messages..... | 50 |
| 3.24 | Channel Search/Out of Range Indication..... | 51 |
| 4. | Electrical Specifications..... | 52 |
| 4.1 | Operating Conditions..... | 52 |
| 4.2 | DC Electrical Characteristics..... | 52 |
| 4.3 | Audio Specification..... | 53 |
| 4.4 | Telephone Line Interface Specification..... | 54 |
| 4.5 | Calling Line Identification Specification..... | 55 |
| 4.6 | Radio Specification..... | 56 |
| 4.6.1 | Frequency Allocation..... | 56 |
| 4.6.2 | Base Unit Frequencies..... | 56 |
| 4.6.3 | Handset Unit Frequencies..... | 56 |

| | |
|--------------|--|
| TITLE | PDL GX Internal Product Specification |
| MODEL | PDL GX |

1. Overview

1.1 General Description

The PDL GX is a 900 MHz digital cordless telephone in a form factor which half the size of the existing VTECH digital product. This is a higher end product by virtue of the level of integration required in order to meet the form factor requirements. This is also a full featured phone which is menu driven with a 2x12 alphanumeric display capable of receiving Caller ID type I and type II.

1.2 Regulatory Standards

As a requirement for sale in the United States, the product will comply with the electrical specifications defined in the following documents:

- FCC Part 15 Radio Emissions Requirements
- FCC Part 68 Telephone Line Interface Requirements
- UL 1459 Safety Requirements

As a requirement for sale in Canada, the *product* will comply with the electrical specifications defined in the following documents:

- IC RSS-210 Radio Emissions Requirements
- IC CS-03 Telephone Line Interface Requirements
- CSA 225 Safety Requirements

In addition to the above mandatory regulations, the recommendations provided in EIA-470-B, TIA 571, TIA631 and IEC801-2 will be used as a guideline.

The caller ID display module meets protocol requirements specified in the following standards documents:

Bellcore TR-NWT-001401 Issue 1
" Visual Message Waiting Indicator"

Bellcore TR-NWT-000030 Issue 2
"Voiceband Data Transmission Interface Generic Requirements"

Bellcore TR-NWT-000031 Issue 4
"CLASS Feature: Calling Number Delivery"

Bellcore TR-NWT-001188 Issue 1
"CLASS Feature: Calling Name Delivery Generic Requirements"

| | |
|--------------|--|
| TITLE | PDL GX Internal Product Specification |
| MODEL | PDL GX |

1.3 Feature List

1.3.1 Basic Features

- Name / number caller ID display with 50 call storage capacity
- 32kbps ADPCM voice coding
- 2 row by 12 character 5x7 dot matrix alpha-numeric LCD display on handset
- 10 channel operation with auto channel selection
- 900 MHz Operation
- 24 bit digital security code for 16.8 million combinations
- DTMF and Pulse dialing
- 20 number/location programmable memory for up to 20 digit phone number
- Automatic search for best available channel
- Low battery detect and warning indicator
- Handset power saving 7 days (less during out-of-range) ¹
- 7.0 Hours continuous talk time ¹
- Volume adjust on handset
- Hearing-aid compatible receiver
- Provisions for spare handset battery pack in the base unit
- Complete battery back-up in case of power failure
- Backlit LCD on the handset
- Auto hang-up when returning the handset to the base cradle.
- Detachable power supply
- Support for headsets with 2.5mm jacks.

¹ Note that this is only when masked ROM is used. Use of external ROM will diminish the talk/standby time.

1.3.2 Unique Features

- Use of E²PROM in base unit for permanent memory storage of security code
- Use of E²PROM in the handset for nonvolatile storage of the security code, CID messages and speed dial numbers
- Handset allows for on-the-fly battery replacement
- Fully digital link between handset and base
- Digitally-scrambled voice communication between handset and base has extremely high immunity to noise and interfering signals
- Out-of-range indication while the handset is in use and in standby mode
- Removable battery pack
- Easy answer - When the phone rings simply press any key (except OFF) on the handset to answer when in idle mode.
- A faster charge (.2C) capability will be provided on the base for the handset battery. The unit will automatically switch over to regular trickle charge (.1C) when required.
- The electrical design will support charging in the face up position.
- Ringer muting

| | | |
|----------------------------|----------------------|----------------------|
| Reference: PRC 00DM | Revision: 3.0 | Page: 7 of 56 |
|----------------------------|----------------------|----------------------|

| | |
|--------------|--|
| TITLE | PDL GX Internal Product Specification |
| MODEL | PDL GX |

1.3.3 Features Not Provided

- The privacy feature is not provided
- Stutter dial tone detection
- Automatic line drop is not provided
- Name dialing is not provided
- Multi handset capability is not provided.
- There is no Page LED on the base
- No other modes of operation available while on HOLD
- Manual channel change has been deleted as the auto channel change algorithm takes care of this function.
- Automatic security code updating when the handset is cradled has been eliminated. The base and handset security codes are now factory preset and stored in E²PROM for the life of the unit. New security codes are therefore not generated every time the unit is re-cradled.

| | |
|-------|---------------------------------------|
| TITLE | PDL GX Internal Product Specification |
| MODEL | PDL GX |

1.4 Cosmetic Styling

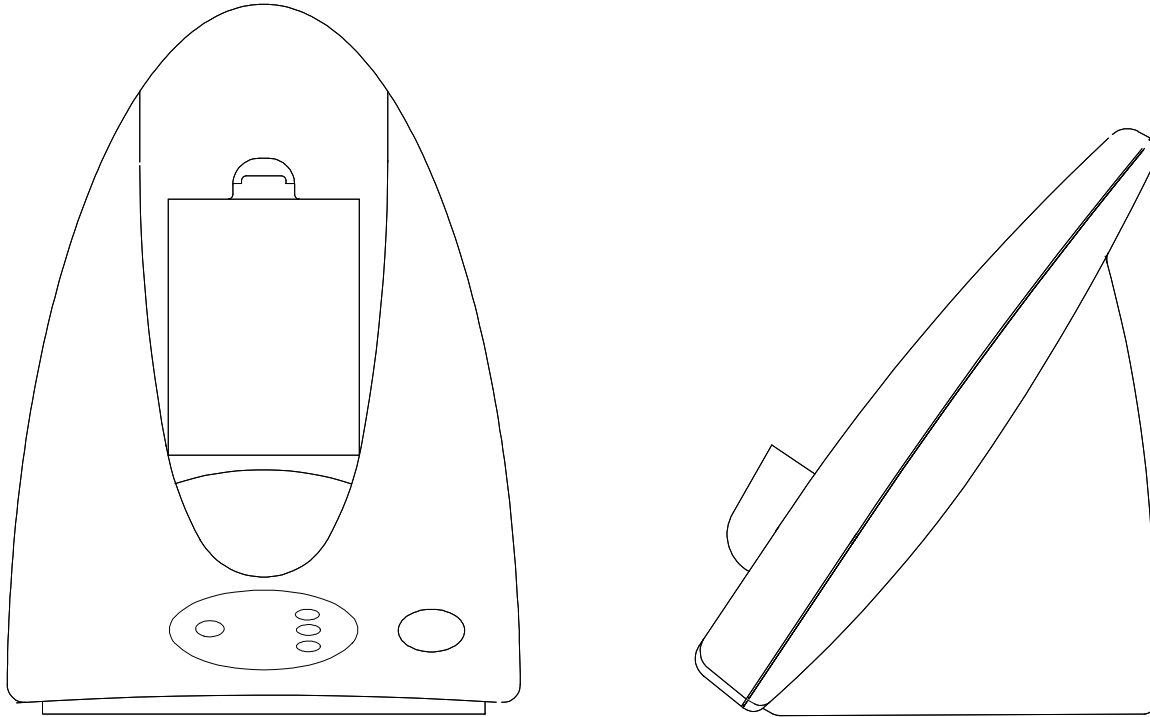

Base Unit

| | |
|-------|---------------------------------------|
| TITLE | PDL GX Internal Product Specification |
| MODEL | PDL GX |

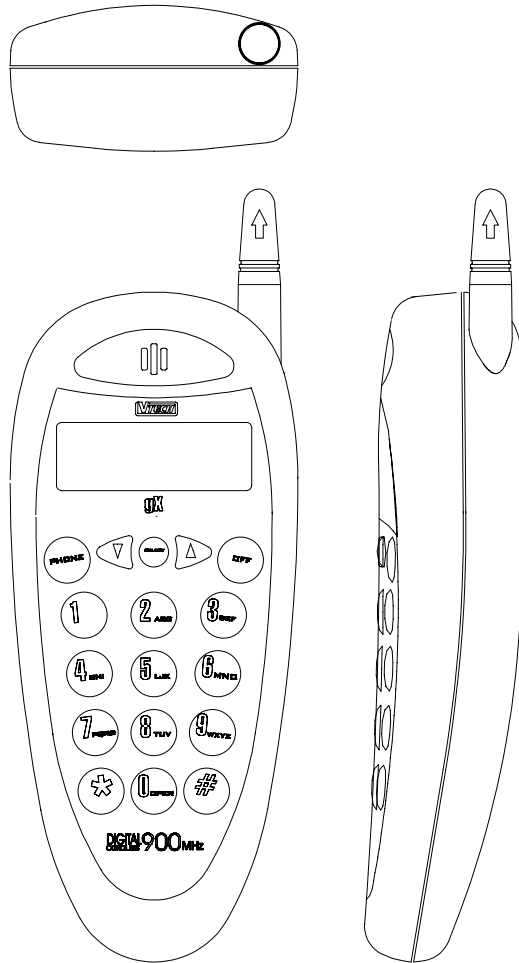

Handset Unit

| | |
|-------|---------------------------------------|
| TITLE | PDL GX Internal Product Specification |
| MODEL | PDL GX |

2. Functional Description

2.1 Handset Display and Keypad Layout

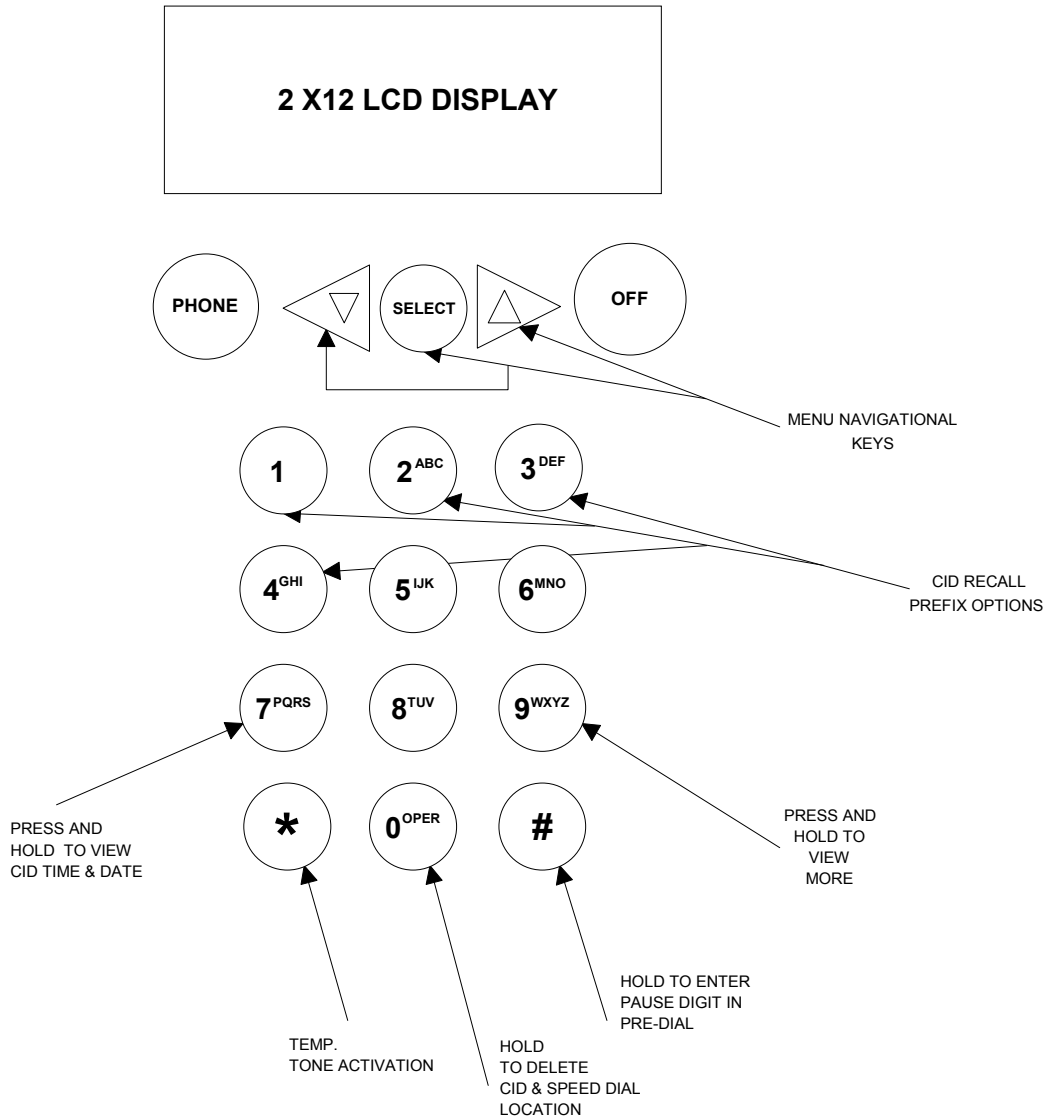

| | |
|-------|---------------------------------------|
| TITLE | PDL GX Internal Product Specification |
| MODEL | PDL GX |

2.2 Base Key Layout and Indicators

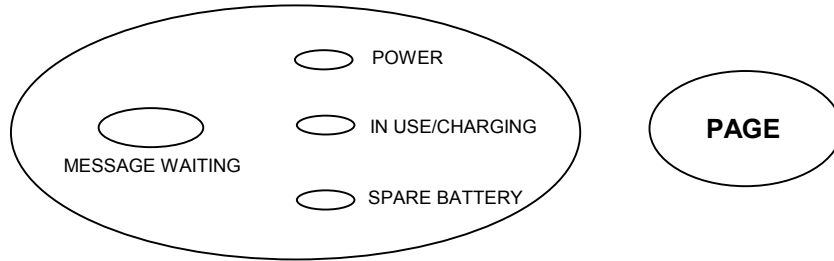

OR

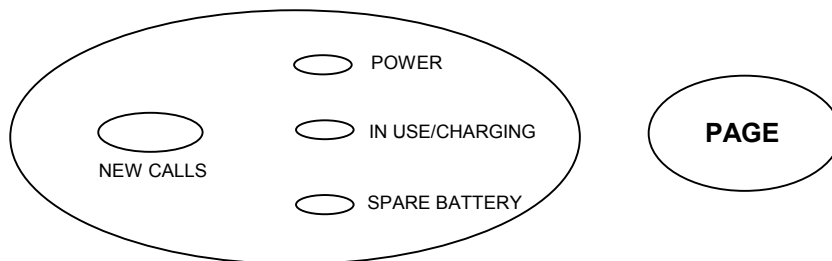

| | |
|--------------|--|
| TITLE | PDL GX Internal Product Specification |
| MODEL | PDL GX |

2.3 Base LED User Interface Status Indicators

The following status is indicated on the base unit LED display:

| Status Type | Description |
|---|---|
| <i>POWER</i> | When the POWER LED is lit solid RED, it indicates that power to the base unit is on. |
| <i>IN USE (off hook)</i> | When the IN USE/CHARGING LED is lit solid GREEN it indicates that the phone is off-hook. |
| <i>RINGING</i> | When the IN USE/CHARGING LED is flashing GREEN at a rate of 16 Hz during the ON cycle of the power ringing signal (2 sec ON/ 4 seconds OFF), it indicates that the telephone line is ringing. |
| <i>CALL HOLD</i> | When the IN USE/CHARGING LED is flashing GREEN at a rate of 4 Hz, it indicates that the telephone line has been placed on hold. |
| <i>CHARGING</i> | When the IN USE/CHARGING LED is lit solid RED it indicates that the cradle is charging the handset battery |
| <i>ON-HOOK & NO HANDSET IN CRADLE</i> | When the IN USE/CHARGING LED is OFF and the POWER LED is lit solid or flashing RED, it indicates that the telephone line is on hook and no handset is installed in the cradle. |
| <i>SPARE BATTERY</i> | When this LED is lit solid RED it indicates that a spare battery is installed in the base unit. |
| <i>MESSAGE WAITING</i> | When this indicator is lit solid RED, it indicates that messages are waiting from the CO. |
| <i>NEW CALLS</i> | When this indicator is lit solid RED, it indicates that you have received new calls when caller ID is supported. |
| <i>POTS MODE</i> | When the POWER LED blinks RED, it indicates that the base is running off of the spare battery and is in POTS mode |

| | |
|--------------|--|
| TITLE | PDL GX Internal Product Specification |
| MODEL | PDL GX |

3. User Interface Specification

3.1 User Interface Status Tones

The following tones are generated in response to various user stimuli:

| Type | Description |
|--------------------------|--|
| <i>CONFIRMATION TONE</i> | Generated whenever a programming command requested by the user is completed satisfactorily |
| <i>ERROR TONE</i> | Generated whenever the user tries to perform an erroneous function or aborts programming |
| <i>KEYCLICK</i> | Generated whenever a key is pressed |

3.2 Navigation/Features/Menus

Various menu items are available to the user when the telephone is on hook or off hook. These menu items are used to enter various modes of operation. The menu items are selectable and scrollable via the navigational keys on the handset which are the ▲, ▼ and the **SELECT** keys – refer to Section 2.1 Handset Display and Keypad Layout.

Note: On some models the up arrow key is designated as a right arrow key, and the down arrow is designated as the left arrow. These shall be treated as equivalent.

To enter menu selection the user must press the **SELECT** key. The first menu item will appear in the display. The user can then review the available choices by either scrolling forward with the ▲ key or scrolling backward with the ▼ key. All menu items will wrap around and can be cycled through in the forward and backward direction.

| | |
|--------------|--|
| TITLE | PDL GX Internal Product Specification |
| MODEL | PDL GX |

3.2.1 On Hook State Menus

The following diagram shows the menu sequence available when the telephone is on hook.

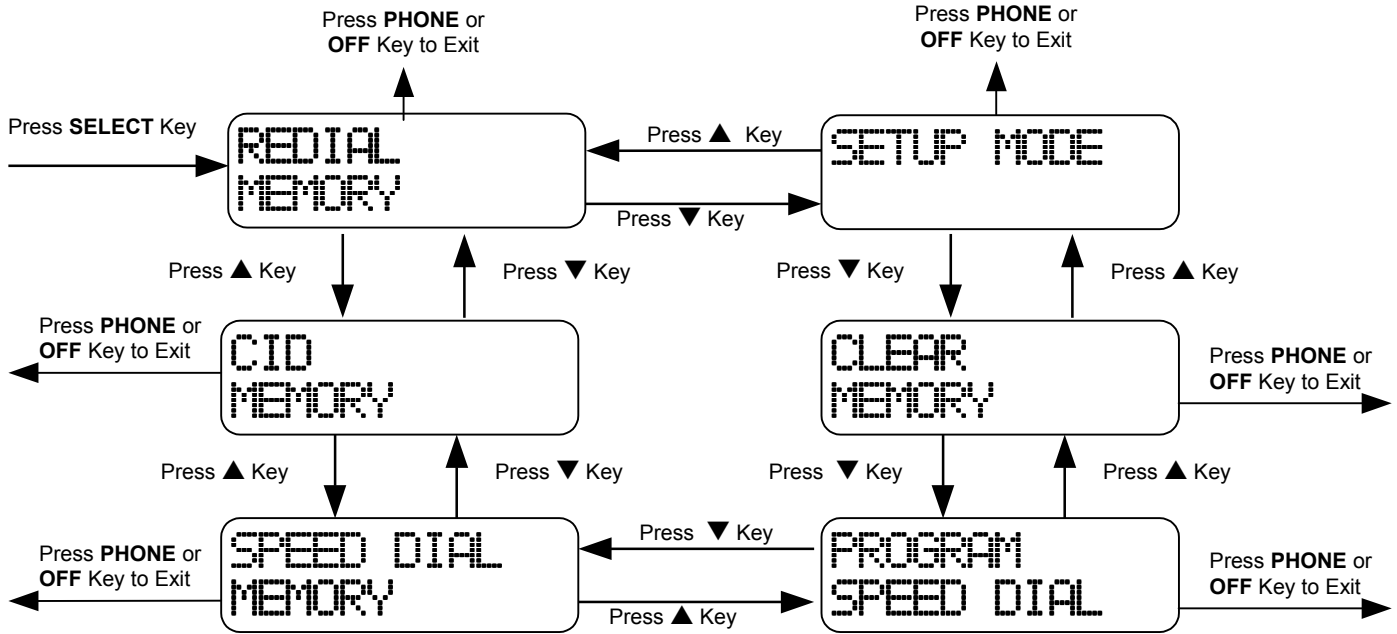

Figure 1 – MENU SEQUENCE IN THE ON HOOK STATE

3.2.2 Off Hook State Menus

The following menus are displayed whenever the phone is off hook.

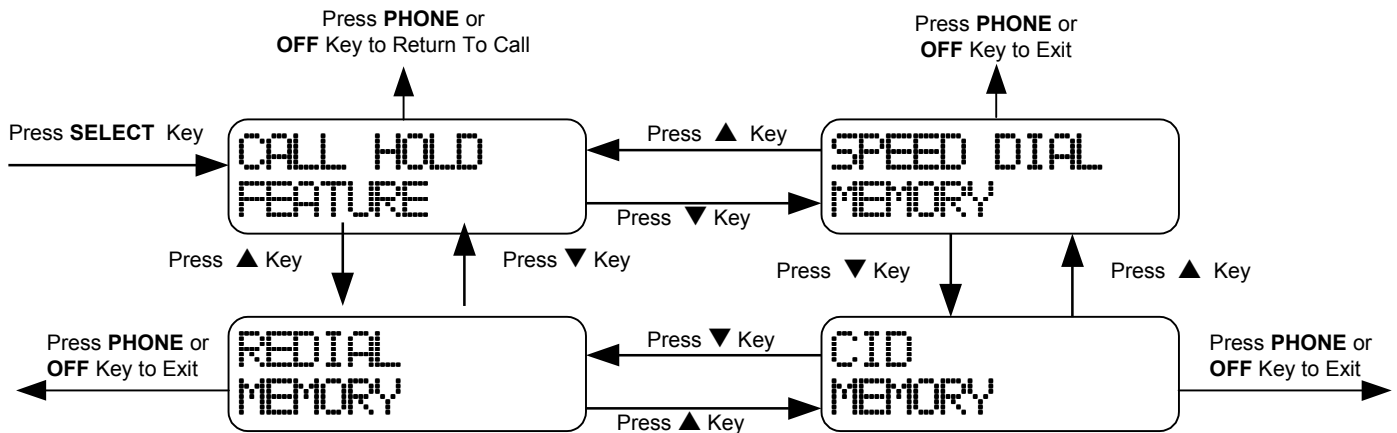
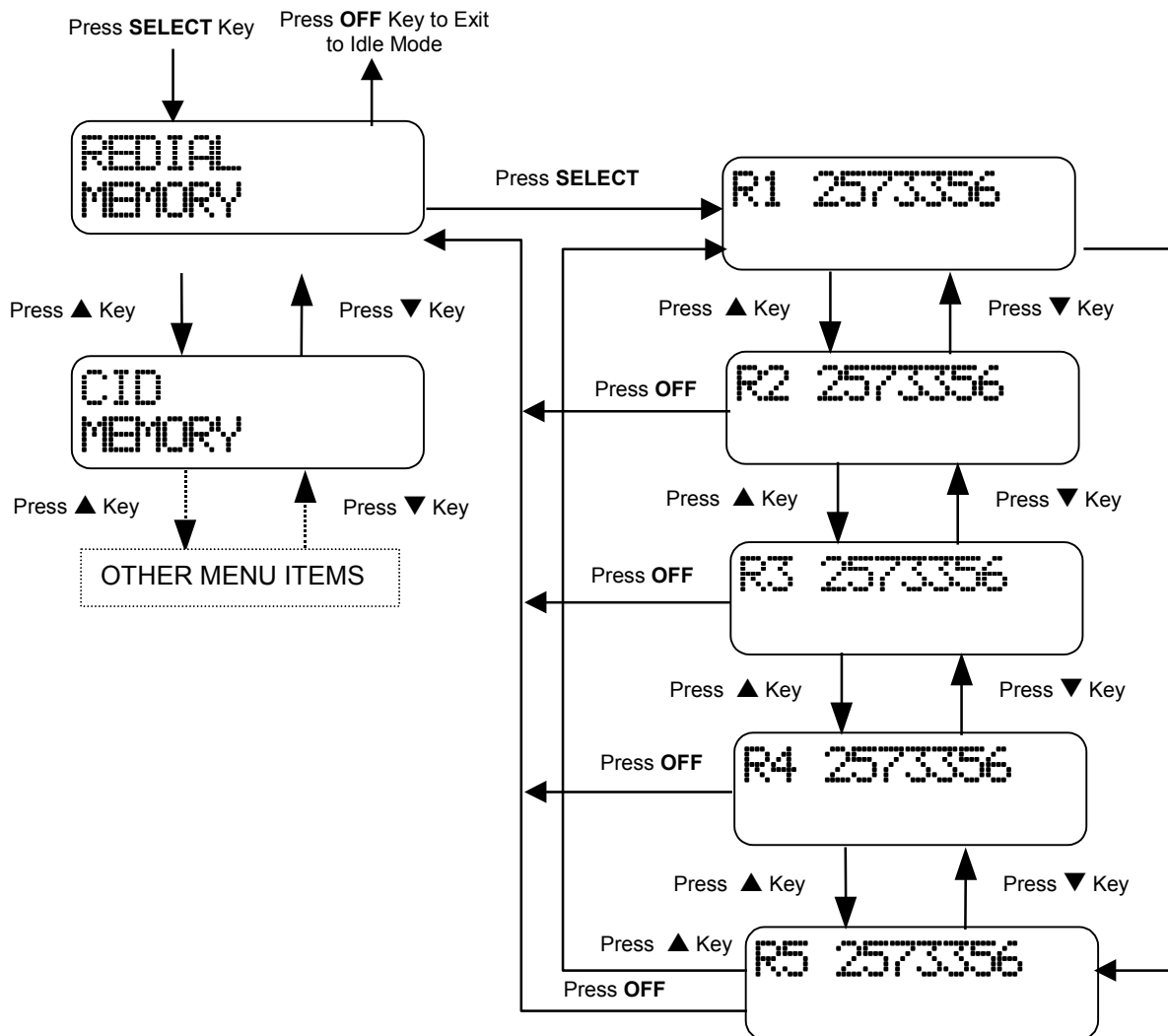

Figure 3.1.2 - MENU SEQUENCE IN THE OFF HOOK STATE

| | |
|--------------|--|
| TITLE | PDL GX Internal Product Specification |
| MODEL | PDL GX |

In general, to exit from the current menu/mode the user can press the **OFF** key; this will bring the user back one step.

For example, using the diagram below, pressing the **SELECT** key while on hook in idle mode will bring up the “REDIAL MEMORY” menu. Subsequent presses of the ▲▼ keys will allow the user to navigate through the other menu items. If the user presses the **SELECT** key when the menu item “REDIAL MEMORY” is displayed, the user will enter the redial memory function. Pressing the ▲▼ keys while in this menu will allow the user to review the last 5 numbers dialed. Pressing the **OFF** key anytime while within this state will return the user back up to the “REDIAL MEMORY” main menu item. Subsequent presses of the ▲▼ keys will allow the user to navigate through the other menu items. Pressing the **OFF** key will exit the user from the main menu and return the user to the idle mode.



3.2.3 Mode Timeout

The handset will have a built in menu display timeout feature whereby if it detects that no key has been pressed within 30 seconds, it will exit the current menu item and return to the appropriate on hook idle or off hook state. The exception to this is when the phone call is placed on hold. If a call is on hold, the call will remain on hold until the user manually takes it off hold or cradles the handset.

| | |
|-------|---------------------------------------|
| TITLE | PDL GX Internal Product Specification |
| MODEL | PDL GX |

3.3 Dial Modes

3.3.1 Pre-Seizure (On-Hook) Dialing or Pre-Dial

Pre-Seizure dialing or Pre-dial refers to a mode of operation where the user enters a phone number or recalls a number from memory to be dialed prior to going off hook or seizing the line.

3.3.1.1 Pre-Dial Digit Entry and Editing

When the handset is idle and in on hook mode, the user can enter the digits of the phone number using the keys **0** through **9** and the ***** and **#** keys. If a dial pause is required in the phone number string, the user can press and hold the **#** key. A **P** will be displayed after 1 second and this indicates a pause interval of 1 second. A total of 20 digits can be entered using pre-dial.

To delete a digit the user can press the **▼** key. The digit to the left of the cursor will be deleted. The cursor is always positioned to right of the last digit on the display. To delete the entire display, press the **OFF** key.

The following shows a sample display of a user entered phone number.

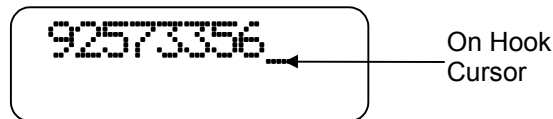

Note: The on hook status is indicated by the cursor as an underscore when pre-dialing

As a general rule in pre-dial mode, the user can append to the displayed pre-dial digits with a phone number recalled from CID, Speed Dial or Redial memory up to the maximum of 20 digits.

To dial the telephone number displayed on the LCD, press the **PHONE** key.

| | |
|-------|---------------------------------------|
| TITLE | PDL GX Internal Product Specification |
| MODEL | PDL GX |

3.3.1.2 Pre-Dial Example

Phone State: On Hook

1. User enters phone number 9 257 3356:

92573356_

2. User wishes to correct the number to enter a dial pause after the 9. The user presses the ▼ key 7 times to put the cursor after the 9 digit :

9_

3. Press and hold the # key for 1 second to insert a dial pause:

9P_

4. User re-enters the rest of the digits 257 3356:

9P2573356_

5. User presses **PHONE** key to go off-hook and complete call:

92573356■

| | |
|--------------|--|
| TITLE | PDL GX Internal Product Specification |
| MODEL | PDL GX |

3.3.2 Post-Seizure Dialing (Off-Hook) or Live Dial

Post-Seizure dialing or Live Dial refers to a mode of operation where the user goes off-hook or seizes the line before entering the phone number or recalling a number from memory to be dialed. This type of dialing is the normal method used in most corded telephones.

Live Dial or off-hook mode is indicated by a solid block cursor as shown in the example display below:

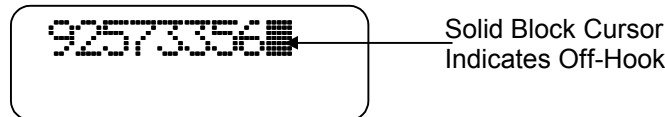

In Live Dial the user can only recall telephone numbers from memory. No programming/editing functions are allowed in Live-dial.

When the user takes the phone off hook without pre-dial digits on the display, the message 'PHONE ON' will be shown.

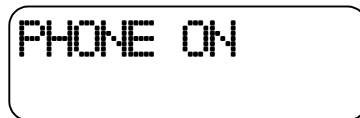

The IN USE/CHARGING LED on the base will be lit **GREEN** to indicate the handset is in use and the telephone line is off-hook. As the user manually enters digits the corresponding DTMF tone will be generated and remain on for the duration the key is held when the dial mode is set to TONE , or, if the dial mode is set to PULSE, the pulse digits will be dialed. A **KEYCLICK** will also be generated to acknowledge the user of the manual entry.

3.4 Using SELECT or PHONE key When Recalling Numbers From Memory

The cordless telephone supports “What You See Is What You Get” (WYSIWYG) dialing when a user recalls any dialing memory location while in pre-dial mode and presses the **PHONE** key instead of the **SELECT** key.

This feature allows the user to scroll through any memory recall locations (e.g. CID Recall, Last Number Redial and Speed Dial) and select the number to be dialed. By pressing the **PHONE** key when in pre-dial mode only, the number as shown on the recall display will be dialed exactly as shown. This feature prevents any dialing errors caused by accidentally leaving digits on the pre-dial display prior to making the memory recall selection.

If a user wishes to recall a memory location for further editing in pre-dial mode, the user can always press the **SELECT** key to recall the number and append it to any digits already entered on the display prior to the memory recall.

| | | |
|----------------------------|----------------------|-----------------------|
| Reference: PRC 00DM | Revision: 3.0 | Page: 19 of 56 |
|----------------------------|----------------------|-----------------------|

| | |
|--------------|--|
| TITLE | PDL GX Internal Product Specification |
| MODEL | PDL GX |

If a user recalls a memory location when in live-dial mode and presses either the **PHONE** or **SELECT** key, the number recalled will be immediately dialed in addition to any digits previously dialed during this call.

3.4.1 Pre-Dial Recall Example Using PHONE Key (WYSIWYG)

1. User enters a few digits in pre-dial mode (e.g. 52)

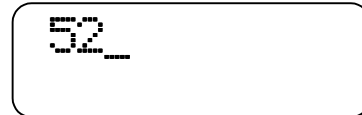

2. The user recalls a number from a redial location R2 which has the number 3334422 stored in it. (See Section 3.6.1 Review/Recalling Most Recently Dialed Numbers from Redial Memory)

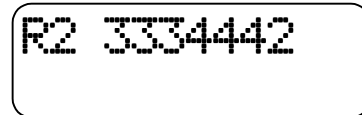

3. User presses **PHONE** key. The previously entered digits 52 are cleared from the pre-dial display, the phone goes off-hook and the number 3334422 is immediately dialed.

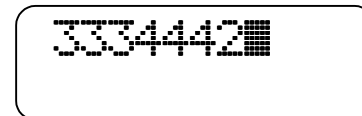

3.4.2 Pre-Dial Recall Using SELECT Key

1. User enters a few digits in pre-dial mode (e.g. 52)

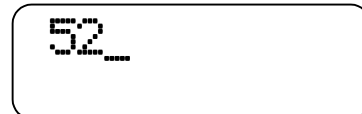

2. The user recalls a number from a redial location R2 which has the number 3334422 stored in it. (See Section 3.6.1 Review/Recalling Most Recently Dialed Numbers from Redial Memory)

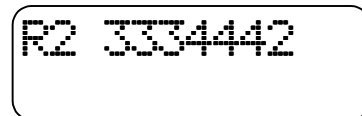

3. User presses **SELECT** key. The redial number is recalled and appended to the previously entered digits as shown:

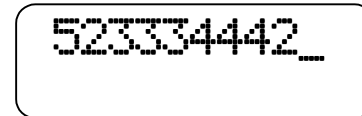

| | |
|--------------|--|
| TITLE | PDL GX Internal Product Specification |
| MODEL | PDL GX |

3.4.3 Live-Dial Recall Using PHONE or SELECT Key

1. User presses **PHONE** key to go off-hook and dials the a telephone number in live-dial mode (e.g. 2245555):
2. The user recalls a number from a redial location R2 which has the number 3334422 stored in it. (See Section 3.6.1 Review/Recalling Most Recently Dialed Numbers from Redial Memory).
3. User presses **PHONE** or **SELECT** key while still in live-dial. The recalled number is dialed out and the display shows the previously dialed number plus the appended recalled redial number.

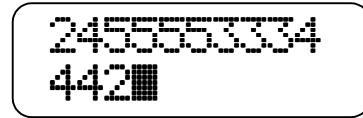
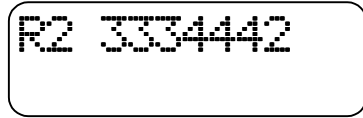
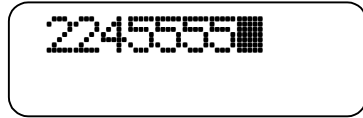

3.5 Placing A Call on Hold

The user can place the call on HOLD when in Live-dial model. This keeps the connection to the destination but with the incoming, and outgoing audio muted. An example of how to place a call on HOLD is shown below:

Phone State: In Use Mode (Off-Hook)

4. Press the **SELECT** key in order to activate the menu. The following will be displayed:
2. The user presses the **SELECT** key again in order to place the call on HOLD and the following will be displayed while the call is on hold:

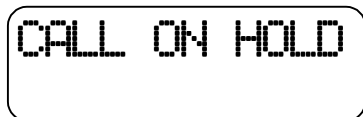

The IN USE/CHARGING LED on the base unit will also flash **GREEN** twice per second to indicate the hold condition at the base station.

To cancel the hold condition the user can simply press the **PHONE** key or the **OFF** key. The user also has the option to terminate the current call on hold by simply cradling the handset into the base unit.

| | |
|-------|---------------------------------------|
| TITLE | PDL GX Internal Product Specification |
| MODEL | PDL GX |

3.6 Last Number Redial

3.6.1 Review/Recalling Most Recently Dialed Numbers from Redial Memory

To access the Redial memory select “REDIAL MEMORY” from the menu. There are 5 Redial locations, which will store the last five telephone numbers dialed. The memory is organized in order of the most recently dialed number in location 1 to the least recent dialed in location 5.

An example of a redial telephone number presented in the display is shown below:

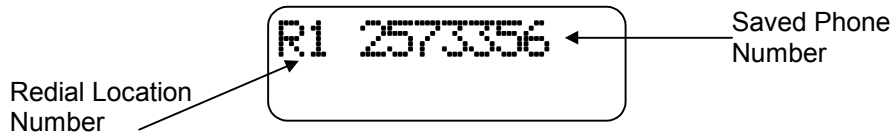

A Redial phone number can be up to a maximum of 20 digits.

The user can scroll through the five Redial locations using the ▼ or ▲ keys.

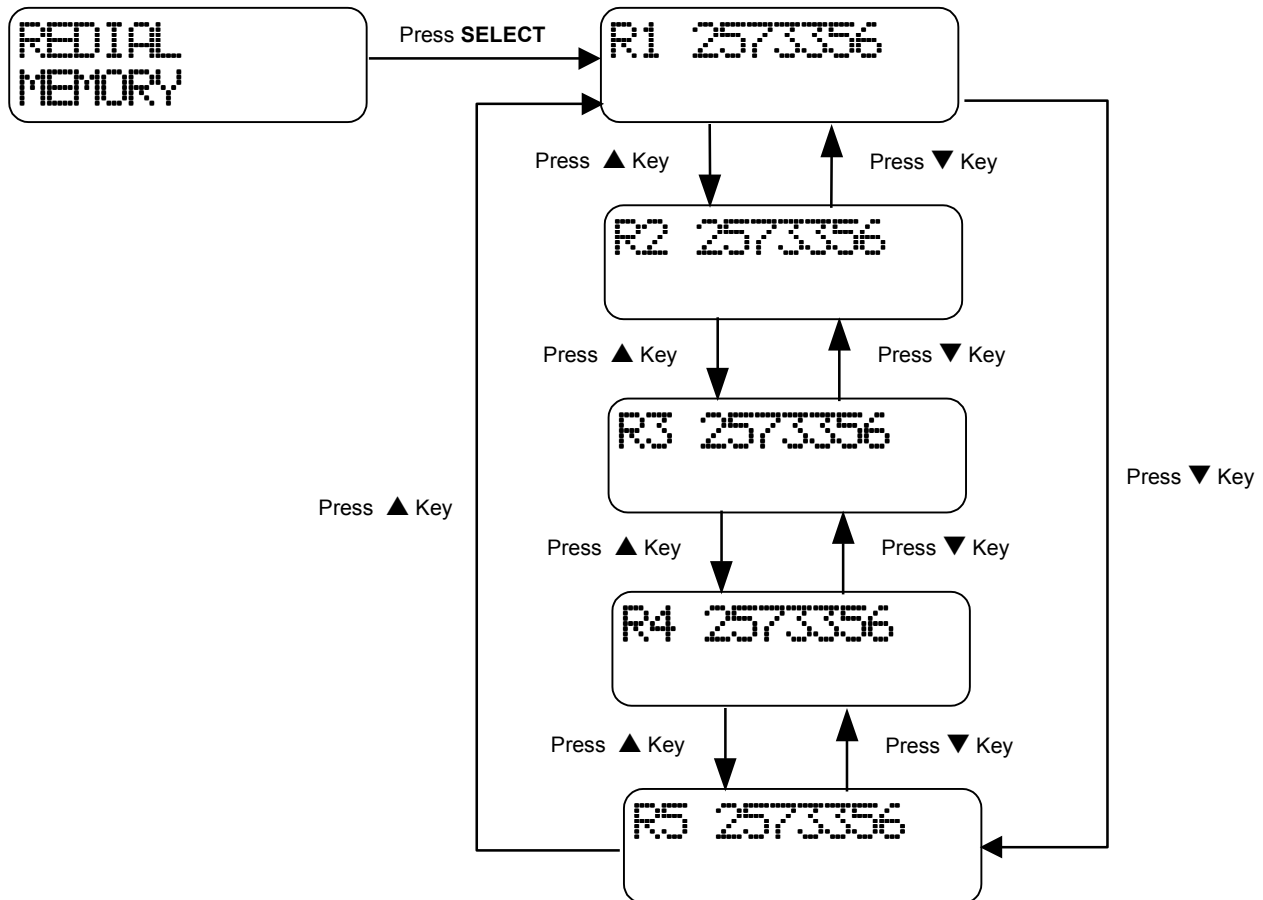

To recall the Redial number for further editing when in pre-dial mode, press the **SELECT** key. Refer to Section 3.3.1.1 Pre-Dial Digit Entry and Editing and Section 3.4 Using SELECT or PHONE key When Recalling Numbers From Memory for more details.

| | |
|--------------|--|
| TITLE | PDL GX Internal Product Specification |
| MODEL | PDL GX |

Note: When Redial numbers are recalled from memory in pre-dial mode using the **SELECT** key, they are automatically appended to any digits already entered on the display. To ensure that only the redial number will be dialed, the user should ensure that no digits appear in the pre-dial display before recalling the redial number entry. See Section 3.4 Using **SELECT** or **PHONE** key When Recalling Numbers From Memory for more details.

After recalling and editing the desired redial number, the user can press the **PHONE** key to go off hook and immediately dial the number on the display.

While in pre-dial mode, the user can directly recall and dial the desired redial number, by scrolling to the desired redial location and then pressing the **PHONE** key. This will cause the telephone to clear any previously entered pre-dial digits, go off-hook, and immediately dial the number in the redial location exactly as displayed.

When recalling redial numbers in live-dial mode, press either the **PHONE** key or the **SELECT** key and this will immediately dial the number in the selected redial location. Note that in live-dial mode, any recalled redial number will be appended to any digits already dialed.

To exit from Redial review without recalling the telephone number, press the **OFF** key. The user is then returned to the menu selection mode.

3.6.1.1 Redial Example Using **PHONE** key from Pre-Dial Mode:

Assume that the user has made 4 previous telephone calls to the following numbers in the following order: 233 4566, 876 1356 , 455 5677 and 257 3356.

Phone State: Idle Mode (On-Hook).

1. To recall the 3rd most recent dialed number from the redial memory, the user first presses the **SELECT** key and the following menu item is displayed:
2. The user presses the **SELECT** key again in order to enter the REDIAL MEMORY function. The phone number of the last call made is displayed:
3. To select the 3rd most recently dialed number, the user scrolls back through the redial list by pressing the ▲ key until record number R3 is found:
4. The user presses the **PHONE** key to dial the number and complete the call.

REDIAL
MEMORY

R1 2573356

R3 8761356

8761356 ■■■

| | |
|-------|---------------------------------------|
| TITLE | PDL GX Internal Product Specification |
| MODEL | PDL GX |

3.6.1.2 Redial Example Using PHONE key from Live-Dial Mode:

Assume that the user has made 4 previous telephone calls to the following numbers in the following order: 233 4566, 876 1356 , 455 5677 and 257 3356.

Phone State: Live Dial Mode (Off-Hook) and user has not entered any digits.

1. To recall the 3rd most recent dialed number from the redial memory, the user first presses the **SELECT** key and the following menu item is displayed:



2. The user presses the **SELECT** key again in order to enter the REDIAL MEMORY function. The phone number of the last call made is displayed:

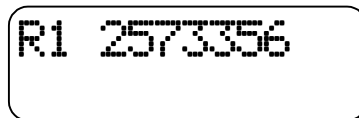

3. To select the 3rd most recently dialed number, the user scrolls back through the redial list by pressing the **▲** key until record number R3 is found:



4. The user presses the **PHONE** key to dial the number and complete the call.

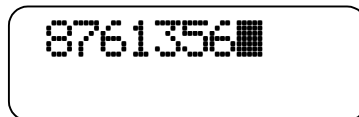

3.6.2 Storing Redial Records

Phone numbers are stored in redial memory only when the phone goes off hook and the call is made. Any subsequent digits entered after the phone has gone off-hook (post line seizure or live dialing) will be appended to the number and saved in the redial memory up to the maximum of 20 digits.

If a user enters a phone number using pre-dial and does not go off-hook, the number will not be saved in redial memory.

Any subsequent dialing digits entered after the **PHONE** key is pressed (live dialing) will also be stored. A combination of the first 20 digits whether pre-dialed and live-dialed will be stored; In the case where there are less than 20 digits, storage will be triggered by activation of a line flash or an **OFF** key press.

After a hook switch flash, the numbers previously dialed are immediately saved in the current redial memory location and all subsequent numbers after the flash are recorded in a new redial memory location.

| | |
|--------------|--|
| TITLE | PDL GX Internal Product Specification |
| MODEL | PDL GX |

3.7 Incoming Calls

3.7.1 Ringing

Both the base and handset have provision to indicate an incoming call once a power ringing signal from the CO has been detected. The base **IN USE** LED will flash at a rate of 16 Hz during the ON cycle of the power ringing signal. If the handset is idle, and the user has not pre-dialed any digits, the handset will display:



The LCD back light will come on as soon as ringing has been detected and ringing and will follow the power ring signal cadence. This message will persist while the CO power ringing signal is active and for 5 more seconds after the last ring signal is received. However, the message will be immediately overwritten by an incoming CID message if received. The handset will ring using the programmed ringer type and level selected in Setup Mode.

3.7.2 Answering the Incoming Call

The user is provided with a quick method of answering the incoming call by pressing any key on the handset (**except the OFF key**) once ringing has been detected and if the phone is in the idle state (no menus active). This feature allows the user to answer the call without having to find the **PHONE** key which may be difficult in a low ambient light condition.

If the user has any menus are active when the phone rings, the user must press the **PHONE** key to answer the call.

3.7.3 Terminating the Incoming Call

The user can press the **OFF** key when the telephone is off hook to terminate the call or by simply cradling the handset back into its base. Pressing the **OFF** key in any menu selection mode will not hang up the call since it will return the user to the menu.

When the handset is returned to the cradle the base **CHARGING** LED will be lit **RED** to indicate the handset is being charged.

| | |
|--------------|--|
| TITLE | PDL GX Internal Product Specification |
| MODEL | PDL GX |

3.8 Calling Line ID Functions

The telephone is capable of decoding, saving and displaying up to 50 calling line ID numbers (CID). Calling line ID is a paid feature provided by the telephone company (TELCO) which sends the telephone number of the caller to the user so that he can identify who is calling before answering the call.

3.8.1 CID Type I

Upon successful reception of the CID data sent by the CO between the first and the second power ringing, the display on the handset will show the name and number field received appropriately.

Name Field: The first 12 characters of this field are displayed.

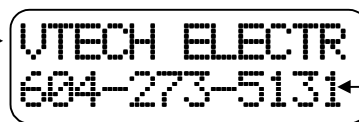

Number Field: Hyphenation is only inserted when the number received is 10 digits

This display will persist for the duration of ringing and will remain active for 5 seconds after the last detected power ring on signal.

Once new valid CID data is received, the new calls counter will be incremented by one.

The name and number field may also display 'PRIVATE' or 'UNAVAILABLE' if it's blocked or is not provided by the CO. If erroneous CID data as is received (as determined by a checksum error) the following message will be displayed:

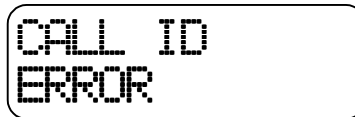

3.8.2 Call Forward Indicator

In some cases, a user may receive calls forwarded from another telephone. To indicate this a 'CF' is displayed in the first character of the number field as shown below:

Call Forward Indicator

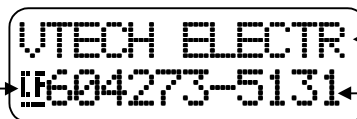

Name Field: The first 12 characters of this field are displayed.

Number Field: Hyphenation is only inserted when the number received is 10 digits

This feature helps a user to identify that the call he received was not made directly to this telephone.

This feature can be disabled via a bit flag in EEPROM during factory programming to support those customers who do not require the feature.

| | |
|--------------|--|
| TITLE | PDL GX Internal Product Specification |
| MODEL | PDL GX |

3.8.3 New Calls Indicator

The handset will display the number of new calls received this will be based on the received CID data. The new calls will count the number of calls received since last CID review. Refer to Section 3.8.1 Review/Recall Telephone Numbers from CID Memory. Once the user reviews the CID records the New Calls status will be cleared.

The following shows an example of a single and multiple new calls display. The new calls display will always displayed on the top line when the handset is idle. This message has the lowest priority and may be over written by other messages.

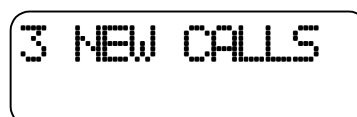
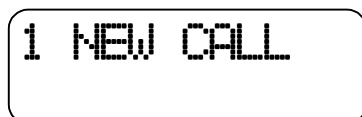

3.8.3.1 New Calls LED Indicator Option

The New Calls LED indicator on the base will flash at a rate of twice per second, on models equipped with this indicator. The base indicator will match the handset New Calls status.

3.8.4 CID Type II

The telephone is capable of receiving Call Waiting CID type II. If during a normal phone call, another call comes in with CID information, alerting tones (subscriber alert signal tone or **SAS**) will be heard in the handset earpiece to notify the user of the 2nd call. The phone will mute both audio paths, acknowledge back to the CO via a DTMF tone and then receive, decode and display the new CID information.

The new CID information will be displayed in the same manner as defined in Section 3.8.1 CID Type I. The new CID information will be displayed for 10 seconds and will then be stored in E²PROM. This new CID information will also cause the New Calls counter to be incremented.

3.8.5 Review/Recall Telephone Numbers from CID Memory.

When the telephone is on-hook, the CID information stored in memory can be reviewed or recalled. To access the CID memory, press the **SELECT** key to bring up the menu. Then use the **▲▼** keys to select "CID MEMORY" from the menu.

A total of up to 50 CID records can be saved. Any saved CID records can be reviewed and recalled. The user can scroll through the CID records using the **▼** or **▲** keys. Any empty CID memory locations will not be displayed. For example, if CID records 01 through 18 are active and the remaining CID records are empty, then if the user presses the **▲** key while displaying record #18, the next record displayed will be record #01.

Upon entering the "CID MEMORY" menu item, the most recent record (record #1) will be displayed. The records are saved such that the most recent record is displayed first and the oldest record is displayed last. The top line of the display will show the record number and the name (if it exists) and the second line will show the phone number (if it exists). An example display is shown below:

| | |
|--------------|--|
| TITLE | PDL GX Internal Product Specification |
| MODEL | PDL GX |

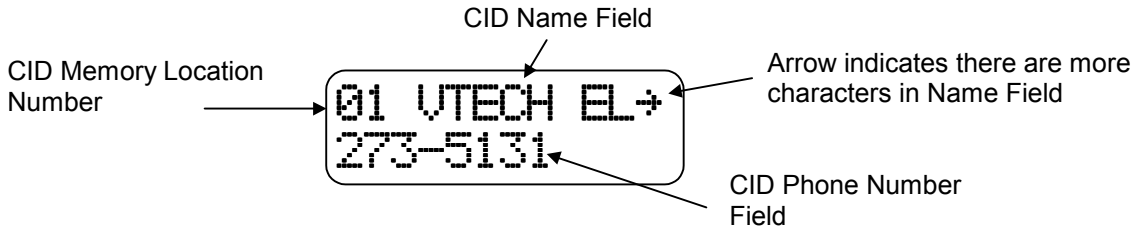

The name and the phone number field may have "PRIVATE" or "UNAVAILABLE" instead. This will depend on the CID information received from the CO.

In the above example the most right character on the top line indicates that there are more characters in the name field. To view the entire name field the user can press and hold the 9 key.



The date and time stamp of the CID record can also be viewed by pressing and holding down the 7 key. The display format of the telephone number with time stamp is shown below.

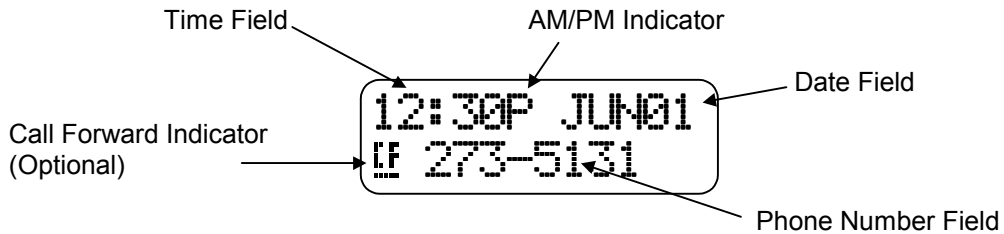

| | |
|--------------|--|
| TITLE | PDL GX Internal Product Specification |
| MODEL | PDL GX |

3.8.5.1 CID Number Recall Options

To recall the telephone number from the CID record for editing or dialing the user can press the following keys to select the dial string options:

Phone State: Idle Mode (On-Hook) and no digits currently entered using pre-dial mode.

Assume that the following CID record exists:



1. Press the **SELECT** key to recall the number exactly as displayed and append them to the digits previously entered on the display. This can be used for Direct Dial Numbers where the telephone company sends the exact number needed to dial the caller. The following will be displayed:

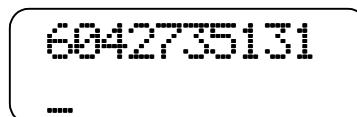

2. Press the **PHONE** key to recall the CID number exactly as displayed, go off-hook and dial the CID number. This can be used for Direct Dial Numbers where the telephone company sends the exact number needed to dial the caller:

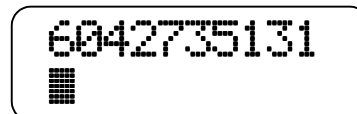

3. Press the **1** key to recall the Long Distance Prefix (1) + Area Code + Exchange Code + Line Code (e.g. 16042735131 -- 11 digits):

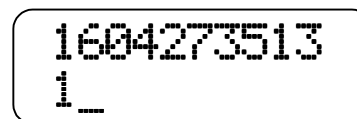

4. Press the **2** key to recall the Area Code + Exchange Code + Line Code (e.g. 6042735131 -- 10 digits):

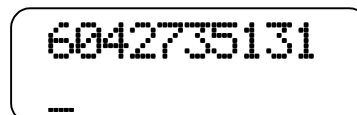

5. Press the **3** key to recall the Long Distance Prefix (1) + Exchange Code + Line Code (e.g. 12735131 -- 8 digits):

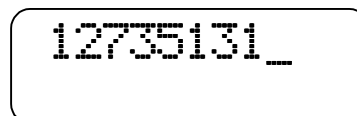

6. Press the **4** key to recall the Exchange Code + Line Code (e.g. 2735131 -- 7 digits):



NOTE: If the CO only sends a 7-digit phone number and the 2 key is pressed, the user will only get the seven-digit phone number. If the 1 key is pressed in this case, a 1 digit will precede the 7 digit phone number.

After recalling the desired CID number using the **SELECT** key and format in pre-dial mode, press the **PHONE** key to go off hook and dial out the phone number displayed. If the telephone was already off-hook, pressing either **SELECT**, **1**, **2**, **3** or **4** will immediately dial the formatted CID number selected and append it to any previously dialed digits.

To exit from memory review without recalling the phone number from the CID record, press the **OFF** key. The user is then returned to the "CID MEMORY" menu item.

| | |
|--------------|--|
| TITLE | PDL GX Internal Product Specification |
| MODEL | PDL GX |

3.8.6 Deleting a CID Record in Review Mode

While reviewing any of the CID record, the user has the ability to delete the current CID record in view. The user presses and holds the **0** key and will be acknowledged with a *KEYCLICK* and the LCD will display the following message:

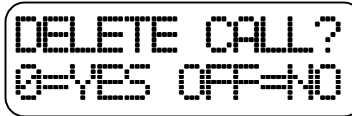

To abort the deletion of the call record, the user must press the **OFF** key. To proceed with the deletion, the user must press the **0** key again. A *KEYCLICK* will be generated to indicate the deletion of the CID record followed by the message:









This message will be removed once deletion has completed. The user is then returned back to CID review. The next oldest CID record will shift into the deleted location. For example if the user deletes location 5, previous location 6 is shifted to 5, previous location 7 is shifted to location 6, and so on. To clear all CID memory, refer to Section 3.10 Clearing CID, Speed Dial Memory and VMWI.

| | |
|--------------|---------------------------------------|
| TITLE | PDL GX Internal Product Specification |
| MODEL | PDL GX |

3.8.7 Call Forward Display of Telephone Numbers

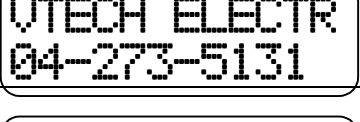
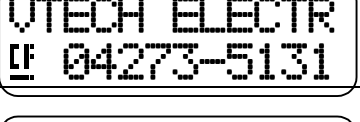
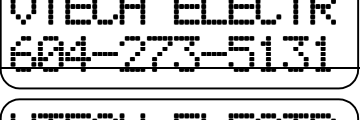
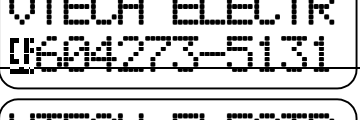
The following examples show how the incoming CID telephone number would be displayed for various length telephone numbers:

| NUMBER OF DIGITS IN TELEPHONE NUMBER | WITHOUT CALL FORWARD DISPLAY ENABLED | WITH CALL FORWARD DISPLAY ENABLED |
|--------------------------------------|---|---|
| 7 |  |  |
| 8 |  |  |
| 9 |  |  |
| 10 |  |  |
| 11 |  |  |

| | |
|--------------|--|
| TITLE | PDL GX Internal Product Specification |
| MODEL | PDL GX |

3.9 Speed Dial Functions

The telephone has 20 speed dial memory locations which can be programmed and recalled for quick access to frequently dialed numbers.

3.9.1 Programming Speed Dial Memory

Programming the Speed Dial Memory is only allowed, in the on hook condition. The user may copy any phone number on the display into any of the 20 locations in the Speed Dial memory. This means that the user can enter the desired digits on the display (pre-dial), and then access the "PROGRAM SPEED DIAL" menu item in order to store it into the Speed Dial Memory.

In general the user can recall a phone number from memory such as CID, Speed Dial or Redial onto the display.

Once all the desired digits to be programmed are shown in the display the user can select the "PROGRAM SPEED DIAL" menu item. An example programming sequence is shown as follows:

3.9.1.1 Program Speed Dial Example

Phone State: On hook

1. Enter or recall the following number to be programmed into speed dial memory while the telephone is on hook.



2. Press **SELECT** key to display the menu:

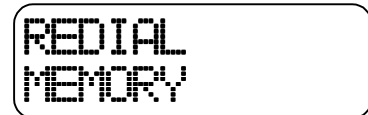

3. Use the ▲▼ keys to select the following menu item:



4. Press the **SELECT** key to select the PROGRAM SPEED DIAL menu item:



5. Enter the 2 digit speed dial memory location under which to store the telephone number (e.g. **18**):



Immediately after entering the 2nd digit, the speed dial location will be programmed with the number 591 6678. If the speed dial entry was correctly saved, a *CONFIRMATION TONE* will be generated.

If the user enters an invalid location number, an *ERROR TONE* will be generated.

| | |
|--------------|--|
| TITLE | PDL GX Internal Product Specification |
| MODEL | PDL GX |

6. The user can abort programming at any time by pressing the **OFF** key. In this case an *ERROR TONE* will be generated and the following will be displayed:



3.9.2 Review/Recall Telephone Number from Speed Dial Memory

To access the Speed Dial memory, select "SPEED DIAL MEMORY" from the menu. There are 20 speed dial memory locations for recall or review. Upon entering the "SPEED DIAL MEMORY" menu item, the user will be prompted with the following display:



The user can directly access any speed dialing location by entering a two digit location number or scroll sequentially through the memory locations using the ▼ or ▲ keys.

The following is an example display of a speed dial location:



The location number is displayed on the top left followed by the stored telephone number.

A total of 20 digits can be stored in any given location.

When the telephone is on-hook, the user can recall and append the speed dial number to any digits already on the display by pressing the **SELECT** key. The user can also press the **PHONE** key to recall and immediately dial the speed dial number as displayed.

If the telephone is already off-hook, the user can immediately recall the selected speed dial number by pressing the **SELECT** or **PHONE** key. The display will show the speed dial number recalled for dialing appended to any other digits previously dialed on this call.

In on-hook mode only, the user may recall the phone number for further editing (i.e., pre-dial) by pressing the **SELECT** key.

To exit from reviewing the Speed Dial review session, press the **OFF** key. The user is then returned to the "SPEED DIAL MEMORY" menu item.

| | |
|--------------|--|
| TITLE | PDL GX Internal Product Specification |
| MODEL | PDL GX |

3.9.2.1 Speed Dial Review Example

An example of a speed dial review is shown as follows:

Phone Mode: Off-Hook (Live Dial) and no previous digits have been dialed.

1. Press the **SELECT** key and the following will be displayed:

CALL HOLD
FEATURE

2. Use the ▲▼ keys to select the following menu item:

SPEED DIAL
MEMORY

3. Press the **SELECT** key to select the “SPEED DIAL MEMORY” menu item:

SPEED DIAL
LOCATION _

4. Directly enter the 2 digit speed dial memory location (e.g. 03):

SPEED DIAL
LOCATION 03

5. Immediately after the 2nd digit is entered, the speed dial number will be displayed:

503 5551212

6. The user can also review other speed dial locations using the ▲▼ keys .

504 16044451
256

7. To make the call to this number press the **PHONE** key and the following will be displayed :

1604445125
☎

| | |
|-------|---------------------------------------|
| TITLE | PDL GX Internal Product Specification |
| MODEL | PDL GX |

3.9.3 Deleting a Speed Dial Location in Review Mode

While reviewing any of the Speed Dial location in on-hook mode, the user has the ability to delete the speed dial location in view. The user presses and holds the **0** key and will be acknowledged with a *KEYCLICK* and the LCD will display the following message:

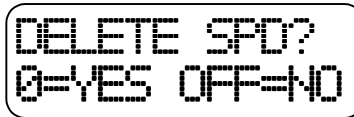

To abort the deletion of the speed dial location, the user must press the **OFF** key. To proceed with the deletion, the user must press the **0** key again. A *KEYCLICK* will be generated to indicate the deletion of the speed dial followed by the message:



This message will be removed once deletion has completed. The user is then returned back to Speed Dial review with the current location containing blanks signifying that it is empty. To clear all Speed Dial memory refer to Section 3.10 Clearing CID, Speed Dial Memory and VMWI.

| | |
|-------|---------------------------------------|
| TITLE | PDL GX Internal Product Specification |
| MODEL | PDL GX |

3.10 Clearing CID, Speed Dial Memory and VMWI

The user can clear all of CID and Speed dial memory by selecting the 'CLEAR MEMORY' menu item. Within this menu item the user can chose to clear either the CID Memory or the Speed Dial memory.

If the VMWI Option is supported, then the VMWI Indicator can also be cleared using the 'CLEAR MEMORY' menu item. VMWI support is indicated using a status bit in EEPROM memory which is programmed in the factory. See Section 3.12 Visual Message Waiting Indication (VMWI) for more information on VMWI.

The **OFF** key can be pressed to cancel the clear function, the user will be returned to the appropriate CLEAR menu item.

3.10.1 Clear Memory Menu Structure If VMWI Is Supported

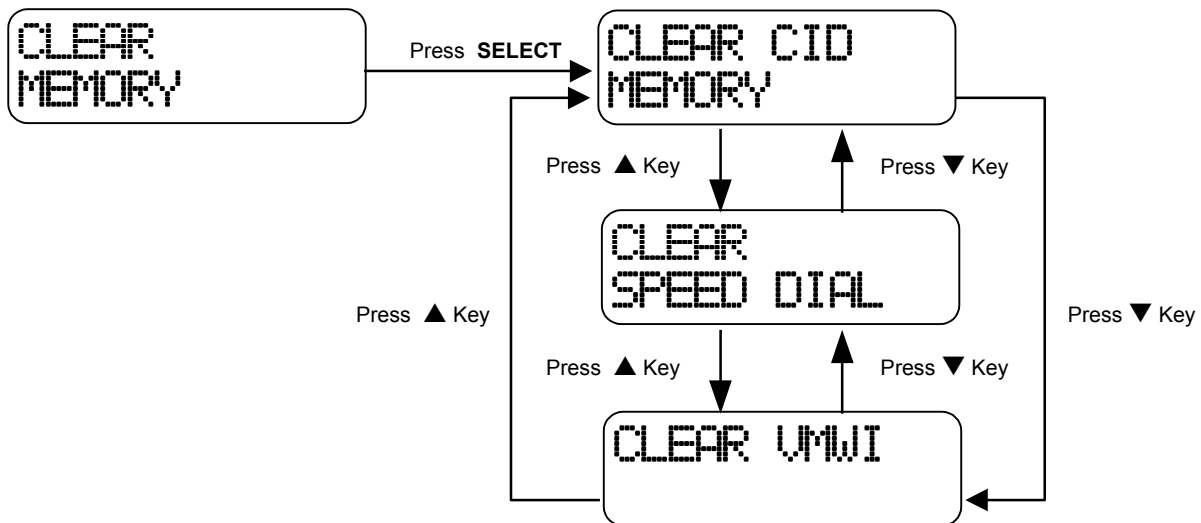

3.10.2 Clear Memory Menu Structure If VMWI Is NOT Supported

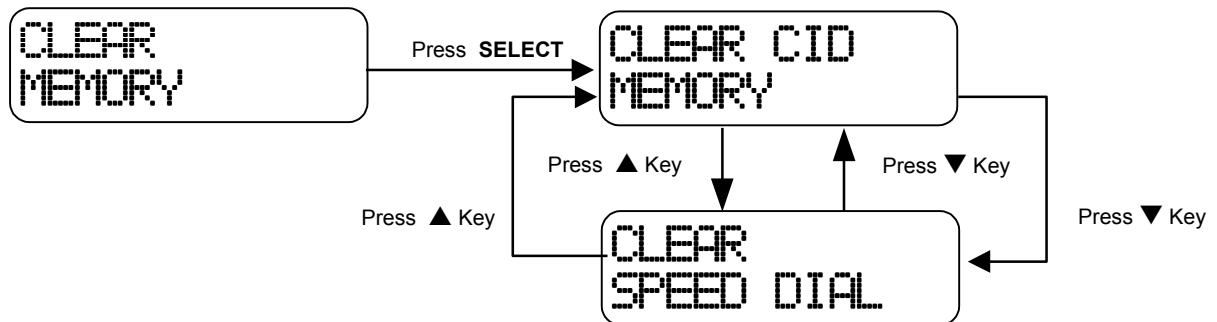

| | |
|--------------|--|
| TITLE | PDL GX Internal Product Specification |
| MODEL | PDL GX |

3.10.3 Clearing The Visual Message Waiting Indicator (If VMWI Option is Supported)

Note: If VMWI is supported as indicated by a status bit in EEPROM memory, then this sub-menu item will be displayed.

The following example shows how to clear the VMWI:

Phone State: On Hook

1. Press the **SELECT** key to activate the menu. The following will be displayed:

```
REDIAL
MEMORY
```

2. Use the **▲▼** keys to select the CLEAR MEMORY menu item:

```
CLEAR
MEMORY
```

3. Press the **SELECT** key to enter the CLEAR MEMORY function and the following will be displayed:

```
CLEAR CID
MEMORY
```

4. Use the **▲▼** keys to choose the desired memory item to clear. In this example, the user will select CLEAR VMWI.

```
CLEAR VMWI
```

5. Press and hold the **0** key to select the item to be cleared. After 1 second, the following message will be displayed to ask the user to confirm the clear:

```
CLEAR VMWI?
0=YES OFF=NO
```

6. Press the **0** key again to clear the selected item. While the item is being cleared, the following confirmation message.

```
CLEARING
VMWI
```

7. After 5 seconds the display will return to the CLEAR MEMORY display item:

```
CLEAR
MEMORY
```

Note: Clearing VMWI will turn off both the message indicator on the handset and the LED indicator on the base. This allows the user to clear the indicators if the Messaging service fails to update the no message waiting status to the user.

| | |
|-------|---------------------------------------|
| TITLE | PDL GX Internal Product Specification |
| MODEL | PDL GX |

3.10.4 Clearing All CID Records

The following example shows how to clear all CID records:

Phone State: On Hook

1. Press the **SELECT** key to activate the menu. The following will be displayed:

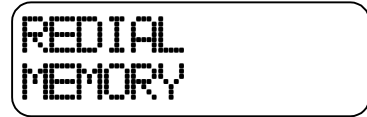

2. Use the ▲▼ keys to select the CLEAR MEMORY menu item:

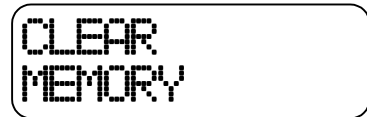

3. Press the **SELECT** key to enter the CLEAR MEMORY function and the following will be displayed :



4. Press and hold the **0** key to select the item to be cleared. After 1 second, the following message will be displayed to ask the user to confirm the clear:

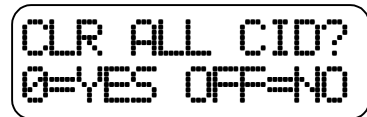

5. Press the **0** key again to clear the selected item. While the item is being cleared, the following confirmation message.



6. After 5 seconds the display will return to the CLEAR MEMORY display item:

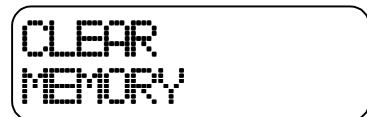

| | |
|-------|---------------------------------------|
| TITLE | PDL GX Internal Product Specification |
| MODEL | PDL GX |

3.10.5 Clearing All Speed Dial Locations

The following example shows how to clear all speed dial locations:

Phone State: On Hook

1. Press the **SELECT** key to activate the menu. The following will be displayed:

REDIAL
MEMORY

2. Use the **▲▼** keys to select the CLEAR MEMORY menu item:

CLEAR
MEMORY

3. Press the **SELECT** key to enter the CLEAR MEMORY function and the following will be displayed :

CLEAR CID
MEMORY

4. Use the **▲▼** keys to choose the desired memory item to clear. In this example, the user will select all speed dial locations.

CLEAR
SPEED DIAL

5. Press and hold the **0** key to select the item to be cleared. After 1 second, the following message will be displayed to ask the user to confirm the clear:

CLR ALL SPD?
0=YES OFF=NO

6. Press the **0** key again to clear the selected item. While the item is being cleared, the following confirmation message.

CLEARING
SPEED DIALS

7. After 5 seconds the display will return to the CLEAR MEMORY display item:

CLEAR
MEMORY

| | |
|--------------|--|
| TITLE | PDL GX Internal Product Specification |
| MODEL | PDL GX |

3.11 Flashing the Line/Switching Over to New Call

The user can press the **PHONE** key to flash (or quickly break) the telephone line.

The flash feature is use for such features as call waiting, where pressing the phone key will cause a hook switch flash and will signal to the CO to place the original call on hold and then switch over to the new call. The new call will remain connected until the user activates another hook switch flash to switch back to the first call again

3.12 Visual Message Waiting Indication (VMWI)

The Visual Message Waiting Indication (VMWI) packet information transmitted by the CO is decoded by the telephone. The status is displayed on the LCD on the handset. Visual Message Waiting information is part of the Integrated Voice Messaging Services provided by the local telephone company if supported.

The VMWI display is an option which can be enabled or disabled via a status bit in EEPROM during factory programming.

Upon detection of a message waiting status from the CO, the indication “MSG. WAITING” is displayed on the second line of the LCD. However, this message will only be displayed when the handset is in idle mode (on hook). This message indication is displayed with the New Calls indicator as shown below.

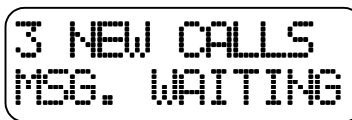

3.12.1 VMWI LED Display Option

If the VMWI display is supported, it can also be optionally indicated on the base via the ‘MESSAGE WAITING’ LED on those models equipped with this feature. It will flash at a rate of twice per second when there is a message waiting at the service provider. This status can also be manually cleared – see Section 3.10 Clearing CID, Speed Dial Memory and VMWI.

| | |
|-------|---------------------------------------|
| TITLE | PDL GX Internal Product Specification |
| MODEL | PDL GX |

3.13 Setup Mode Options

There are three user configurable items, which are accessible through the “SETUP MODE” menu. All settings in setup will be kept in non-volatile memory.

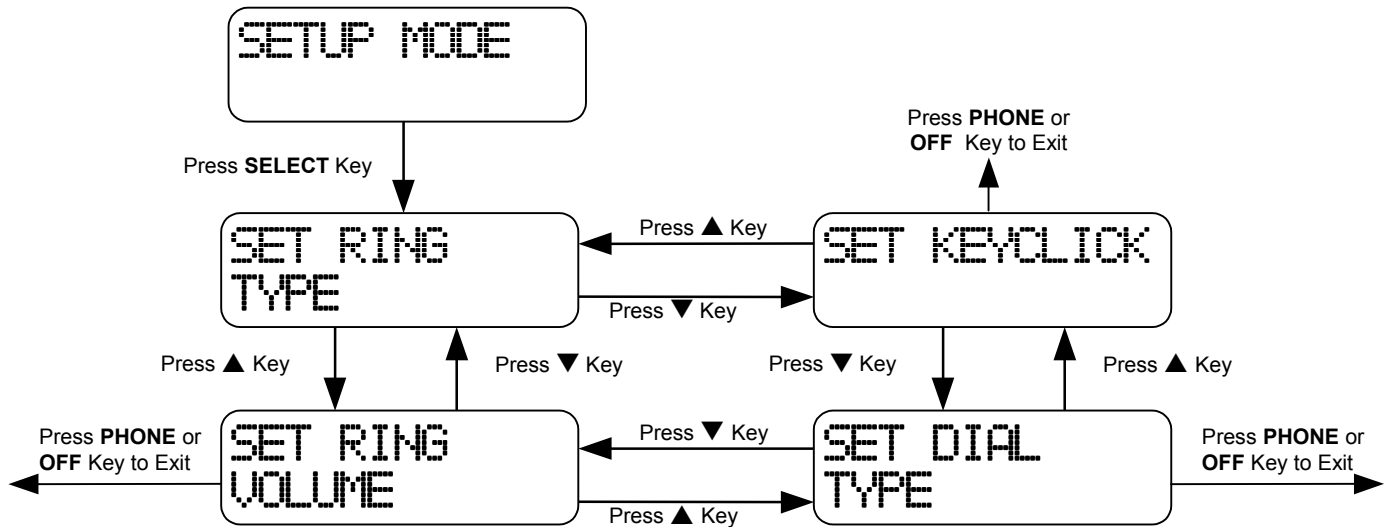

| | |
|-------|---------------------------------------|
| TITLE | PDL GX Internal Product Specification |
| MODEL | PDL GX |

3.13.1 Ring Type Setting (4 selection and OFF)

To set the ring type, select the “RING TYPE” menu item in setup mode. The user can use the ▲▼ keys to select the ringer tone type from OFF and 1 through 4. The associated ringing tone will be activated for 2 seconds after a change in ringer type value is made. To exit the ring type setup, press the **OFF** key to return to the “RING TYPE” menu item. The original ring type setting prior to entering this mode will be maintained unless the user confirms the desired setting by pressing the **SELECT** key after selecting the ring type number.

The default factory setting is ring type 1.

The following example shows how to set the ringer type to 4.

Phone State: On Hook

1. Press the **SELECT** key to activate the menu. The following will be displayed :



2. Use the ▲▼ keys to select the SETUP MODE menu item:



3. Press the **SELECT** key to enter the SETUP MODE function and the following will be displayed:



4. Press the **SELECT** key to display the current RING TYPE setting and allow editing of the RING TYPE parameter:



5. Use the ▲▼ keys to select ringer type 4:

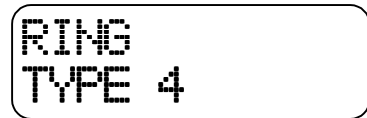

6. Press the **SELECT** key to save the new ringer type. A *CONFIRMATION TONE* will be generated. Use the ▲▼ keys to select the next SETUP MODE item to program.



| | |
|--------------|--|
| TITLE | PDL GX Internal Product Specification |
| MODEL | PDL GX |

3.13.2 Ringer Volume Control (High or Low)

To set the ringer volume, the user must select the “SET RING VOLUME” menu item in setup mode. The display will show the current setting.

The user can set the ringer volume to high or low by pressing the ▲ or ▼ key. The selected ringer type will activate for 2 seconds during the volume adjustment to allow the user to hear the selected level. To confirm the desired setting press the **SELECT** key, otherwise press **OFF** to exit setting the ringer volume.

The default factory ringer volume setting is High.

The following display shows how to set the ringer volume to low.

Phone State: On Hook

1. Press the **SELECT** key to activate the menu. The following will be displayed :

REDIAL
MEMORY

2. Use the ▲▼ keys to select the SETUP MODE menu item:

SETUP MODE

3. Press the **SELECT** key to enter the SETUP MODE function and the following will be displayed:

SET RING
TYPE

4. Use the ▲▼ keys to select the SET RING VOLUME menu item:

SET RING
VOLUME

5. Press the **SELECT** key to display the current RING VOLUME setting and allow editing of the RING VOLUME parameter:

RING
VOLUME HIGH

6. Use the ▲▼ keys to select the LOW volume setting:

RING
VOLUME LOW

7. Press the **SELECT** key to save the new ringer type. A *CONFIRMATION TONE* will be generated. Use the ▲▼ keys to select the next SETUP MODE item to program.

SET RING
VOLUME

| | |
|--------------|--|
| TITLE | PDL GX Internal Product Specification |
| MODEL | PDL GX |

3.13.3 Dialing Type Selection (Tone or Pulse)

To set the dialing type, the user must select the “SET DIAL TYPE” menu item in setup mode. The display will show the current setting. The user can setup the telephone for either TONE or PULSE dialing by pressing the ▲ or ▼ key. To confirm the desired setting press the **SELECT** key, otherwise press **OFF** to exit setting the dialing type.

The default factory setting of dial type is Tone.

The following display shows how to set the dialing type to pulse.

Phone State: On Hook

1. Press the **SELECT** key to activate the menu. The following will be displayed :

REDIAL
MEMORY

2. Use the ▲▼ keys to select the SETUP MODE menu item:

SETUP MODE

3. Press the **SELECT** key to enter the SETUP MODE function and the following will be displayed:

SET RING
TYPE

4. Use the ▲▼ keys to select the SET DIAL TYPE menu item:

SET DIAL
TYPE

5. Press the **SELECT** key to display the current DIAL TYPE setting and allow editing of the DIAL TYPE parameter:

DIAL TYPE
TONE

6. Use the ▲▼ keys to select the PULSE setting:

DIAL TYPE
PULSE

7. Press the **SELECT** key to save the new ringer type. A *CONFIRMATION TONE* will be generated. Use the ▲▼ keys to select the next SETUP MODE item to program.

SET DIAL
TYPE

| | |
|--------------|--|
| TITLE | PDL GX Internal Product Specification |
| MODEL | PDL GX |

3.13.4 Keyclick Selection (On or Off)

To enable or disable keyclick, the user must select the “KEYCLICK” menu item in setup mode. The display will show the current setting. The user can turn the keyclick ON or OFF by pressing the ▲ or ▼ key. To confirm the desired setting press the **SELECT** key, otherwise press **OFF** key to exit setting the dialing type.

The default factory setting of keyclick is On.

The following display shows how to turn the keyclick off.

Phone State: On Hook

1. Press the **SELECT** key to activate the menu. The following will be displayed :

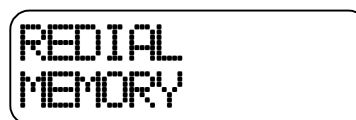

2. Use the ▲▼ keys to select the SETUP MODE menu item:



3. Press the **SELECT** key to enter the SETUP MODE function and the following will be displayed:



4. Use the ▲▼ keys to select the SET KEYCLICK menu item:



5. Press the **SELECT** key to display the current KEYCLICK setting and allow editing of the KEYCLICK parameter:



6. Use the ▲▼ keys to select the OFF setting:



7. Press the **SELECT** key to save the new ringer type. A *CONFIRMATION TONE* will be generated. Use the ▲▼ keys to select the next SETUP MODE item to program.



| | |
|--------------|--|
| TITLE | PDL GX Internal Product Specification |
| MODEL | PDL GX |

3.14 Page Key Operation

As a convenience feature, the PAGE key on the base can be used to page a handset as a means of signaling the user or to help locate a misplaced handset.

Pressing the PAGE key when the telephone is on hook causes the handset to ring 5 times and display the message:



To stop the handset from ringing during an on hook page, press any key.

Pressing the **PAGE** key when the telephone is off hook causes the handset to ring once and display the above message for < 2 seconds.

The default volume for the page ring is HIGH.

3.15 In Use/Charging LED Indicator

3.15.1 Red/Green LED Option

The In Use/Charging LED is a dual mode indicator. When the telephone is off-hook or in use, the indicator will be lit **GREEN**.

When the handset is on the cradle and charging the indicator will be lit **RED**.

When the telephone line is on hold, the In Use/Charging LED will flash **GREEN** at a 4 Hz rate.

When the telephone line is ringing, the In Use/Charging LED will flash **GREEN** at a rate of 16 Hz during the ON cycle of the power ringing signal.

3.15.1.1 In Use/Charging LED Display State Priority (Red/Green LEDs)

| LED Display State | Indication | Priority |
|------------------------------------|---|-----------------|
| Ringing | 16 HZ FLASHING GREEN during ON power ring cycle | 1 (HIGHEST) |
| On Hold | 4 Hz FLASHING GREEN | 2 |
| In Use | SOLID GREEN | 3 |
| Charging | SOLID RED | 4 |
| No Handset in Cradle and Idle Mode | OFF | 5 (LOWEST) |

3.15.2 All Red LED Option

The In Use/Charging LED is a dual mode indicator. When the telephone is off-hook or in use, the indicator will be lit **low intensity RED**.

When the handset is on the cradle and charging the indicator will be lit **high intensity RED**.

When the telephone line is on hold, the In Use/Charging LED will flash **low intensity RED** at a 4 Hz rate.

| | | |
|----------------------------|----------------------|-----------------------|
| Reference: PRC 00DM | Revision: 3.0 | Page: 46 of 56 |
|----------------------------|----------------------|-----------------------|

| | |
|--------------|--|
| TITLE | PDL GX Internal Product Specification |
| MODEL | PDL GX |

When the telephone line is ringing, the In Use/Charging LED will flash **low intensity RED** at a rate of 16 Hz during the ON cycle of the power ringing signal.

3.15.2.1 In Use/Charging LED Display State Priority (All Red LEDs)

| LED Display State | Indication | Priority |
|------------------------------------|---|-----------------|
| Ringing | 16 HZ FLASHING LOW INTENSITY RED during ON power ring cycle | 1 (HIGHEST) |
| On Hold | 4 Hz FLASHING LOW INTENSITY RED | 2 |
| In Use | SOLID LOW INTENSITY RED | 3 |
| Charging | SOLID HIGH INTENSITY RED | 4 |
| No Handset in Cradle and Idle Mode | OFF | 5 (LOWEST) |

3.16 Temporary Tone Activation

When the unit is setup for PULSE dialing (see Section 3.13 Setup Mode Options for details on dial type setup), the user can temporarily switch to tone mode by pressing the * key. This tone mode shall remain active until the OFF key is pressed.

3.17 Ear Piece Volume Adjustment

The user can adjust the volume level of the incoming audio by pressing the ▲ or ▼ key. This can only be done while the phone is off hook, not on HOLD, and not in any menu selection modes. The initial press of either the ▲ or ▼ key will bring up the volume display at the current setting.

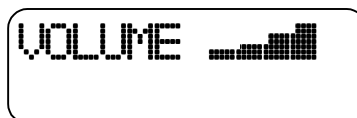

To adjust the volume press the ▲ or ▼ key to select the desired volume level. The number of filled characters shown on the display denotes the volume levels. There are in total, 4 volume levels.

The volume level display will remain active for 5 seconds after the last ▲ or ▼ key press.

| | |
|-------|---------------------------------------|
| TITLE | PDL GX Internal Product Specification |
| MODEL | PDL GX |

3.18 Spare Battery/POTS mode

This telephone has provision to charge a spare handset battery in the base unit. This spare battery also powers the base during an AC power failure. This mode of operation is referred to as POTS mode; which stands for Plain Old Telephone System. When a spare battery is installed, it is indicated on the base by the SPARE BATTERY LED being lit solid RED. When POTS mode is in effect and a spare battery is installed, the SPARE BATTERY LED flashes RED.

The handset will also display the following message when POTS mode is active:



CHECK AC
POWER

3.19 Low Battery Warning

When the handset battery voltage drops below the specified value in Section 4.2 DC Electrical Characteristics. The handset will have the message 'LOW BATTERY' on the top line of the display



LOW BATTERY

A warning tone is emitted from the handset when the phone is first activated during a low battery condition. The low battery warning tone and message is suppressed if the user was in any other modes of operation, such as CID, Speed Dial review, etc. Until the LCD is cleared of other messages, a timer will count up 5 seconds after which, the low battery warning tone is generated and the low battery warning is displayed on the LCD.

3.20 Parallel Set Indication

When another extension is off hook on the same phone line, and when the unit is in standby mode, the telephone will detect this condition and inform the user.

The handset LCD will display the following when the unit detects that another extension on the same line is off-hook



EXTENSION
IN USE

This display will remain on continuously for the duration of the condition. This display supersedes the 'XX NEW CALLS' display. This display is not active during an out of range condition.

The 'XX NEW CALLS' is returned to the display when the 'EXTENSION IN USE' message is cancelled.

There will be no parallel set indication visible on the base unit.

| | | |
|---------------------|---------------|----------------|
| Reference: PRC 00DM | Revision: 3.0 | Page: 48 of 56 |
|---------------------|---------------|----------------|

| | |
|--------------|--|
| TITLE | PDL GX Internal Product Specification |
| MODEL | PDL GX |

3.21 Headset Jack

A jack capable of mating with a 2.5mm plug headset is provided on the handset. When the headset is plugged in, the earpiece receiver and handset microphone are disconnected and the headset earpiece and microphone are used for conversation instead.

3.22 No Telephone Line Connected

If the phone cannot detect any DC from the telephone line, the following message will be displayed on the handset to prompt the user to check that the base unit is connected to the telephone line.

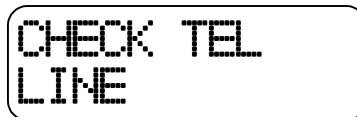

| | |
|-------|---------------------------------------|
| TITLE | PDL GX Internal Product Specification |
| MODEL | PDL GX |

3.23 Display Priority of Non Mode Specific Messages

| PRIORITY | MESSAGE DISPLAY |
|---------------------|--|
| 1 HIGHEST | CHANNEL SEARCHING... |
| 2 | OUT OF RANGE OR PAGING |
| 3 | RINGER OFF |
| 4 | INCOMING CALL OR <CID NAME> <CID NUMBER> |
| 5 | LOW BATTERY |
| 6 | CHECK AC POWER |
| 7 | ×× NEW CALLS AND/OR MSG. WAITING |
| 8 LOWEST | EXTENSION IN USE OR CHECK TEL. LINE |

| | |
|-------|---------------------------------------|
| TITLE | PDL GX Internal Product Specification |
| MODEL | PDL GX |

3.24 Channel Search/Out of Range Indication

When the handset is off-hook and the RF link is broken between the handset and base, the handset alerter will emit a beep signaling a “CHANNEL SEARCHING..” condition as the handset begins scanning for the base.



The “CHANNEL SEARCHING..” indication will remain on the LCD as the handset tries to reestablish communication with the base. If this is not done within 30 seconds, the unit will display “CALL DROPPED” for 3 seconds and will then enter standby mode (idle/low power mode). At intervals of 10 seconds, the handset will wake up and display “CHANNEL SEARCHING..” again as it scans all 10 channels (channels 0 through 9) before blanking the display and reentering standby mode.

Note: Once entering standby mode while in an out-of-range condition, the handset will emit out-of-range tones at 10 second intervals until the battery dies or the handset is able to re-establish communication with the base. In this condition, the battery life will be greatly diminished.

If the **PHONE** key is pressed while the unit is in an out-of-range condition and in standby mode, a **KEYCLICK** will be generated and after two seconds the out-of-range warning beep is generated and channel search will be initiated. The “CHANNEL SEARCHING..” message then appears on the display for 30 seconds. After 30 seconds the unit will display “CALL DROPPED” for 3 seconds and enter standby mode.

If the unit is within range of the base, the handset will automatically re-establish the link within 15 seconds. The unit will then display:

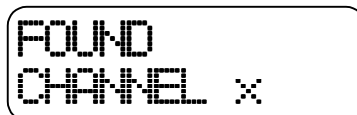

for 3 seconds and then blank the display and enter into standby mode.

| | |
|--------------|--|
| TITLE | PDL GX Internal Product Specification |
| MODEL | PDL GX |

4. Electrical Specifications

4.1 Operating Conditions

| | Parameter | Min | Typ | Max | Units |
|--|---|------------|--------------------|-----------------|--------------|
| | Operating Temperature Range | 0 | 25 ¹ | 40 ² | °C |
| | Base Unit Operating Voltage (AC Voltage, 60Hz) | 96 | 120 ¹ | 144 | Vrms |
| | Base Unit Operating Voltage (AC Adapter Output) | | 9 ¹ | | Vdc |
| | Handset Operating Voltage ² | 3.2 | 3.6 ^{1,3} | 4.2 | Vdc |

Notes:

1. Typical value represents the nominal testing value
2. NiMH Battery should not be operated above 40 °C.
3. Handset operates from a 3-cell NiMH Battery.

4.2 DC Electrical Characteristics

Specifications marked with * are guaranteed at the nominal testing temperature and voltage on all units with the use of automated production test equipment (ATE)

| | Parameter | Min | Typ | Max | Units |
|---|---|------------|------------|------------|--------------|
| * | Base Unit Current - Standby Mode ^{1,2} | 90 | | 118 | mA |
| * | Base Unit Current - Talk Mode ^{1,2} | 120 | | 158 | mA |
| | Handset Current - Sleep Mode ³ | | TBD | TBD | mA |
| * | Handset Current - Wake Mode | 41 | | 51 | mA |
| * | Handset Current - Talk Mode | 61 | | 86 | mA |
| * | Handset Sleep Duration - Standby Mode | TBD | | TBD | ms |
| | Handset Wake Duration - Standby Mode | | TBD | TBD | ms |
| * | Low Battery Detection Threshold (HS) | | 3.5 | | Vdc |
| * | ASIC Shutdown Threshold (HS) | 3.1 | | | Vdc |
| | Handset Standby Time | 7 | | | Days |
| | Handset Continuous Talk Time | 7 | | | Hours |
| | Fast Charge – Handset Battery | | 120 | | mA |
| | Slow Charge – Handset Battery | | 60 | | mA |
| | Spare Battery Charge | | 30 | | mA |

Notes:

1. DC current from 9V power supply
2. Cradle and spare battery charge currents = 0mA
3. Averaged over one complete wake up cycle.

| | |
|--------------|--|
| TITLE | PDL GX Internal Product Specification |
| MODEL | PDL GX |

4.3 Audio Specification

Specifications marked with * are guaranteed at the nominal testing temperature and voltage on all units with the use of automated production test equipment (ATE).

| | Parameter | Min | Typ | Max | Units |
|---|---|------------|------------|------------|--------------|
| * | Transmit Objective Loudness Rating (TOLR) ¹ | -40 | -46 | -53 | dB |
| * | Receive Objective Loudness Rating (ROLR) ^{1,2} | 51 | +46 | 41 | dB |
| * | Sidetone Objective Loudness Rating (SOLR) ³ | +3 | +8 | +19 | dB |
| * | Receive volume adjustment range | 12 | TBD | TBD | dB |
| * | Transmit Direction Acoustic Overload (into microphone) ⁴ | 105 | | | dBspl |
| * | Receive Direction Acoustic Overload (from receiver) ⁴ | 105 | | | dBspl |
| | Transmit Direction Noise ⁵ | | | 20 | dBrnC |
| | Receive Direction Noise ^{2,5} | | | 40 | dB(A) |
| | Peak Acoustic Pressure ⁶ | | | 130 | dBspl |

Notes:

1. Tested using 0kft of simulated telephone line
2. Tested at normal (low) volume level
3. Base unit connected to 0kft of simulated telephone line terminated with 900Ω
4. Acoustic level that results in 5% THD, measured at 1kHz through a 5kHz lowpass filter
5. Handset isolated from sound input and mechanical disturbances
6. Tested at high volume level

| | |
|--------------|--|
| TITLE | PDL GX Internal Product Specification |
| MODEL | PDL GX |

4.4 Telephone Line Interface Specification

Specifications marked with * are guaranteed at the nominal testing temperature and voltage on all units with the use of automated production test equipment (ATE).

| | Parameter | Min | Typ | Max | Units |
|---|---|------------|------------|------------|--------------|
| * | DTMF Frequency Tolerance | -1.5 | | +1.5 | % |
| * | DTMF Low Group Tone Level ¹ | -7.5 | -5.0 | -4.0 | dBm |
| * | DTMF High Group Tone Level ¹ | -5.5 | -3.0 | -2.0 | dBm |
| | DTMF Combined Tone Level ¹ | | | +2.0 | dBm |
| | DTMF High Group Pre-emphasis (Twist) | | 2.0 | 4.0 | dB |
| | Pulse Dialing Break Duration | | 60 | | ms |
| | Pulse Dialing Make Duration | | 40 | | ms |
| | Pulse Dialing Rate | | 10 | | pps |
| | Ring Detection Frequency ^{2,3} | 15 | | 68 | Hz |
| | Ring Response Voltage ³ | 40 | | | Vrms |
| | Ring No-Response Voltage ⁴ | | | 25 | Vrms |

Notes:

1. Measured across a 900Ω terminating impedance
2. The ringer must ring with signals within this range
3. Measured with a frequency of 20Hz
4. The ringer must not ring with signals within this range

| | |
|--------------|--|
| TITLE | PDL GX Internal Product Specification |
| MODEL | PDL GX |

4.5 Calling Line Identification Specification

| Parameter | Min | Typ | Max | Units |
|----------------------------------|------------|------------|------------|--------------|
| Receive Space Frequency | 2178 | 2200 | 2222 | Hz |
| Receive Mark Frequency | 1188 | 1200 | 1212 | Hz |
| Receive Baud Rate | 1188 | 1200 | 1212 | Baud |
| Mark FSK Detector Sensitivity | -32 | | -12 | dBm |
| Space FSK Detector Sensitivity | -36 | | -32 | dBm |
| FSK Detector Twist | -10 | | +10 | dB |
| CAS Detection Sensitivity | -32 | | | dBm |
| Channel Seizure Delays | | | 300 | Bits |
| Immunity to Stuffed Mark Bits | | | 360 | Bits |
| CAS | | | | |
| Frequency limits Lower Tone | 2023.5 | 2130 | 2236.5 | Hz |
| Upper Tone | 2612.5 | 2130 | 2887.5 | Hz |
| Dynamic Range (per tone) | -32 | | -14 | dBm |
| Twist | | | < 6 | dB |
| Tone Duration | 75 | | 85 | mS |
| ACK | | | | |
| Signal Duration | 55 | | 65 | mS |

Notes:

| | |
|--------------|--|
| TITLE | PDL GX Internal Product Specification |
| MODEL | PDL GX |

4.6 Radio Specification

| | |
|---------------------------------|-------------------------------|
| RF radiated field strength | <50 mV/meter @ 3m |
| RF Channel Spacing | 300 kHz |
| Channel Bandwidth | 150 kHz (20dB bandwidth) |
| Receive IF Frequency | 10.7MHz |
| Operating Temperature Range | 0 to +50°C |
| Handset Transmission Frequency | 925.05 - 927.75 MHz |
| Base Transmission Frequency | 902.3 - 905.0 MHz |
| Transmitter Frequency Stability | ±5 kHz, 0 to +50°C |
| Receiver Noise Figure | < 5.5dB |
| Sensitivity for 30dB SINAD | < -106 dBm at duplexer |
| Image Rejection (RF) | > 60 dB |
| Adjacent Channel Rejection | > 55 dB |
| Receiver Muting Level | Between -109 dBm and -107 dBm |

4.6.1 Frequency Allocation

The RF channels are allocated in fixed pairs as indicated in the tables below. The duplex frequency is maintained at a fixed 22.75MHz for all 10 channels.

4.6.2 Base Unit Frequencies

| Channel # | Transmit Frequency | Receive Frequency | Rx LO Frequency |
|-----------|--------------------|-------------------|-----------------|
| 1 | 902.30 MHz | 925.05 MHz | 914.35 MHz |
| 2 | 902.60 MHz | 925.35 MHz | 914.65 MHz |
| 3 | 902.90 MHz | 925.65 MHz | 914.95 MHz |
| 4 | 903.20 MHz | 925.95 MHz | 915.25 MHz |
| 5 | 903.50 MHz | 926.25 MHz | 915.55 MHz |
| 6 | 903.80 MHz | 926.55 MHz | 915.85 MHz |
| 7 | 904.10 MHz | 926.85 MHz | 916.15 MHz |
| 8 | 904.40 MHz | 927.15 MHz | 916.45 MHz |
| 9 | 904.70 MHz | 927.45 MHz | 916.75 MHz |
| 10 | 905.00 MHz | 927.75 MHz | 917.05 MHz |

4.6.3 Handset Unit Frequencies

| Channel # | Transmit Frequency | Receive Frequency | Rx LO Frequency |
|-----------|--------------------|-------------------|-----------------|
| 1 | 925.05 MHz | 902.30 MHz | 913.00 MHz |
| 2 | 925.35 MHz | 902.60 MHz | 913.30 MHz |
| 3 | 925.65 MHz | 902.90 MHz | 913.60 MHz |
| 4 | 925.95 MHz | 903.20 MHz | 913.90 MHz |
| 5 | 926.25 MHz | 903.50 MHz | 914.20 MHz |
| 6 | 926.55 MHz | 903.80 MHz | 914.50 MHz |
| 7 | 926.85 MHz | 904.10 MHz | 914.80 MHz |
| 8 | 927.15 MHz | 904.40 MHz | 915.10 MHz |
| 9 | 927.45 MHz | 904.70 MHz | 915.40 MHz |
| 10 | 927.75 MHz | 905.00 MHz | 915.70 MHz |