

Go to www.vtechphones.com to register your product for enhanced warranty support and the latest VTech product news.

DM1215 DM1215-2 Audio Baby Monitor

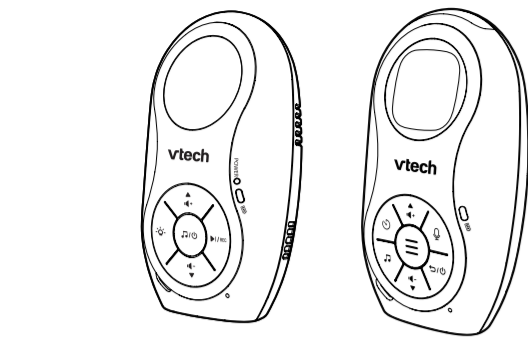

vttech® User's manual

For more support information

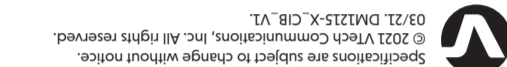

Specifications are subject to change without notice.
© 2023 VTech Communications, Inc. All rights reserved.
09/21 DM1215-X-018_018_017

| | |
|------------------------|--|
| Frequency control | Crystal controlled PLL synthesizer |
| Transmit frequency | Baby unit: 192L536 - 1928.448 MHz Parent unit: 192L536 - 1928.448 MHz |
| Channels | 5 |
| LCD | 35 (x) x 21.2 (y) mm B&W LCD |
| Normal effective range | Maximum power allowed by FCC and IC. Actual operating range may vary according to environmental conditions at the time of use. |
| Power requirement | Baby unit / Parent unit: 1.2 V 400 mAh Ni-MH battery Baby unit / Parent unit power adapters: |
| Output | 6V DC 400mA |

TECHNICAL SPECIFICATIONS

IMPORTANT SAFETY INSTRUCTIONS

The applied nameplate is located at the bottom of the baby unit's base.

When using your equipment, basic safety precautions should always be followed to reduce the risk of fire, electric shock and injury, including the following:

- Follow all warnings and instructions marked on the product.
- Adult setup is required.
- CAUTION:** Do not install the baby unit at a height above 2 meters.
- This product is not a substitute for adult supervision of the infant. Supervising the infant is the parent's or caregiver's responsibility. This product could cease operating, and therefore you should not assume it will continue working properly for any given period of time. Further, this is not a medical device and should not be used as such. This product is intended to assist you in supervising your baby.
- Do not use this product near water. For example, do not use it next to a bath tub, wash bowl, kitchen sink, laundry tub or swimming pool, or in a wet basement or shower.
- CAUTION:** Use only the batteries provided. There may be a risk of explosion if a wrong type of battery is used for the parent unit. The batteries cannot be subjected to high or low extreme temperature and low air pressure at high altitude during use, storage or transportation. Disposal of batteries into fire or a hot oven, or mechanically crushing or cutting or the batteries can result in an explosion. Leaving the batteries in an extremely high temperature surrounding environment can result in an explosion or the leakage of flammable liquid or gas. Batteries subjected to extremely low air pressure may result in an explosion or the leakage of flammable liquid or gas. Dispose of used battery according to the information in the RBRC seal.
- Use only the adapters included with this product. Incorrect adapter polarity or voltage can seriously damage the product.
- Use only adaptors and batteries listed below.

Power adapter information:
VTech Telecommunications Ltd.
Model: VTD5EU06040

Rechargeable batteries information:
ShenZhen Hipower Technology Co., Ltd. (HFR-AAA400)
GPI International Limited (VTRHC043C076)
YIYANG CORUN BATTERY CO., LTD (KH-AAA400)
AAA 400mAh NiMH

- The power adapters are intended to be correctly oriented in a vertical or floor mount position. The prongs are not designed to hold the plug in place if it is plugged into a ceiling, under-the-table or cabinet outlet.
- For pluggable equipment, the socket-outlet shall be installed near the equipment and shall be easily accessible.
- Unplug this product from the wall outlet before cleaning. Do not use liquid or aerosol cleaners. Use a damp cloth for cleaning.
- Unplug the power cords before replacing batteries.
- Do not cut off the power adapters to replace them with other plugs, as this causes a hazardous situation.
- Do not allow anything to rest on the power cords. Do not install this product where the cords may be walked on or crimped.
- This product should be operated only from the type of power source indicated on the marking label. If you are not sure of the type of power supply in your home, consult your dealer or local power company.
- Do not overload wall outlets or use an extension cord.
- Do not place this product on an unstable table, shelf, stand or other unstable surfaces.
- This product should not be placed in any area where proper ventilation is not provided. Slots and openings in the back or bottom of this product are provided for ventilation. To protect them from overheating, these openings must not be blocked

- Never push objects of any kind into this product through the slots because they may touch dangerous voltage points or create a short circuit. Never spill liquid of any kind on the product.
- To reduce the risk of electric shock, do not disassemble this product, but take it to an authorized service facility. Opening or removing parts of the product other than specified access doors may expose you to dangerous voltages or other risks. Incorrect reassembly can cause electric shock when the product is subsequently used.
- You should test the sound reception every time you turn on the units or move one of the components.
- Periodically examine all components for damage.
- There is a very low risk of privacy loss when using certain electronic devices, such as baby monitors, cordless telephones, etc. To protect your privacy, make sure the product has never been used before purchase, reset the baby monitor periodically by powering off and then powering on the units, and power off the baby monitor if you will not use it for some time.
- Children should be supervised to ensure that they do not play with the product.
- The product is not intended for use by persons (including children) with reduced physical, sensory or mental capabilities, or lack of experience and knowledge, unless they have been given supervision or instruction concerning use of the appliance by a person responsible for their safety.

SAVE THESE INSTRUCTIONS

- Cautions**
- Use and store the product at a temperature between 32°F and 104°F.
 - Do not expose the product to extreme cold, heat or direct sunlight. Do not put the product close to a heating source.
 - Batteries should not be exposed to excessive heat such as bright sunshine or fire.

Warning—Strangulation Hazard—Children have STRANGLED in cords. Keep this cord out of the reach of children (more than 3 ft (0.9 m) away). Do not remove this tag.

- Never place the baby unit inside the baby's crib or playpen. Never cover the baby unit with anything such as a towel or a blanket.
- Other electronic products may cause interference with your baby monitor. Try installing your baby monitor as far away from these electronic devices as possible: wireless routers, radios, cellular telephones, intercoms, room monitors, televisions, personal computers, kitchen appliances and cordless telephones.

Precautions for users of implanted cardiac pacemakers
Cardiac pacemakers (applies only to digital cordless devices):
Wireless Technology Research, LLC (WTR), an independent research entity, led a multidisciplinary evaluation of the interference between portable wireless devices and implanted cardiac pacemakers. Supported by the U.S. Food and Drug Administration, WTR recommends to physicians that:

- Pacemaker patients**
- Should keep wireless devices at least six inches from the pacemaker.
 - Should NOT place wireless devices directly over the pacemaker, such as in a breast pocket, when it is turned ON. WTR's evaluation did not identify any risk to bystanders with pacemakers from other persons using wireless devices.
- Electromagnetic fields (EMF)**
This VTech product complies with all standards regarding electromagnetic fields (EMF). If handled properly and according to the instructions in this user's manual, the product is safe to be used based on scientific evidence available today.

WHAT'S IN THE BOX

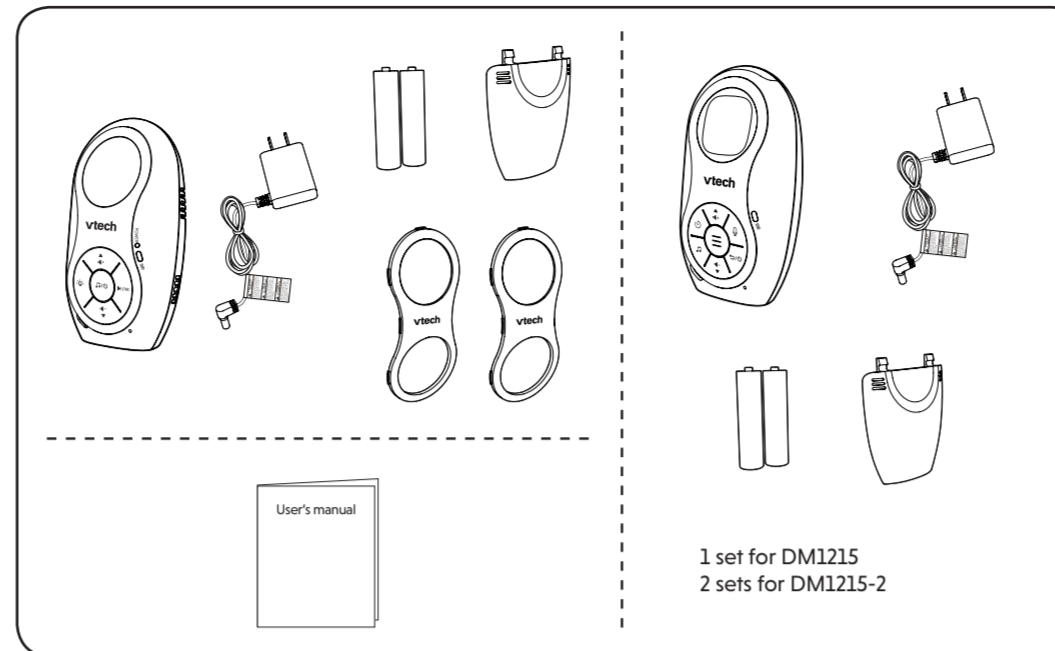

1 set for DM1215
2 sets for DM1215-2

1 CONNECT AND CHARGE THE BATTERIES

Install the parent unit batteries

NOTES

- Use only the batteries supplied with this product.
- If the parent unit will not be used for a long time, disconnect and remove the batteries to prevent possible leakage.

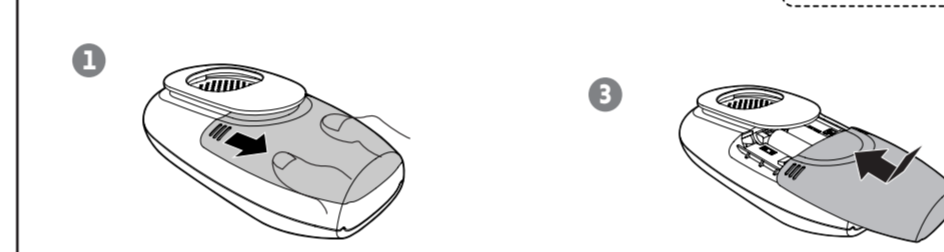

Install the baby unit batteries

NOTES

- Use only the batteries supplied with this product.
- If the baby unit will not be used for a long time, disconnect and remove the batteries to prevent possible leakage.

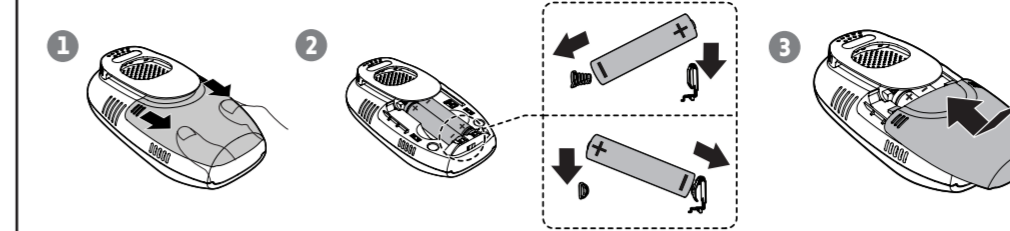

Connect the baby monitor

NOTES

- Use only the power adapters supplied with this product.
- Make sure the baby monitor is not connected to switch-controlled electric outlets.
- Connect the power adapters in a vertical or floor mount position only. The adapters' prongs are not designed to hold the weight of baby monitor, so do not connect them to any ceiling, under-the-table, or cabinet outlets. Otherwise, the adapters may not properly connect to the outlets.
- Make sure the parent unit, the baby unit and the power adapter cords are out of reach of children.

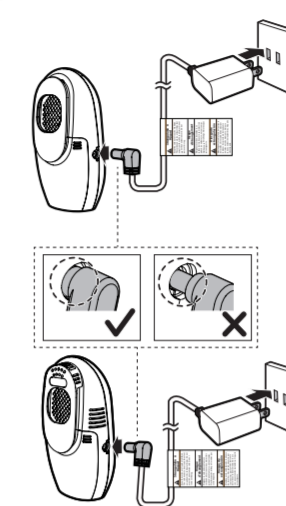

Charge the batteries before use

When you have connected and turned on the parent unit and baby unit, the batteries will be charged automatically.

NOTES

- Before using the baby monitor for the first time, charge the parent unit and baby unit batteries for 12 hours.
- It takes longer to charge the batteries when the parent unit and baby unit are turned on. To shorten the charging time, turn the parent unit and baby unit off while charging.
- The standby time varies depending on the sensitivity level you set, your actual use and the age of the batteries.

The battery icon indicates the battery status (see the following table).

| BATTERY INDICATORS | BATTERY STATUS | ACTION |
|---|--|--|
| The parent unit beeps and the screen displays | The batteries have very little charge and may be used for only a short time. | Charge without interruption (about 30 minutes). |
| The battery icon becomes solid | The batteries are fully charged. | To keep the batteries charged, connect it to AC power when not in use. |

2 POWER ON OR OFF THE BABY MONITOR

- Press and hold to power on the baby unit. The power light turns on. Press and hold to power off the baby unit. The power light turns off.

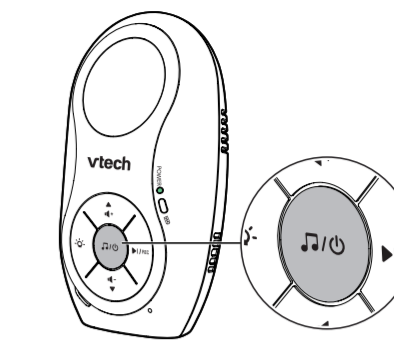

- Press and hold to power on or off the parent unit.

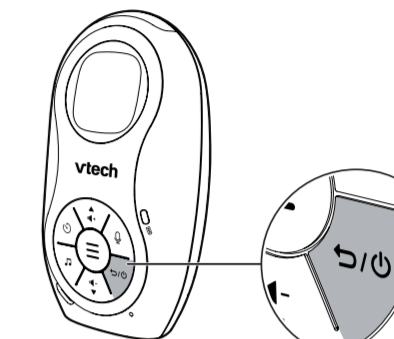

3 STATUS CHECK

After you power on both your baby unit and parent unit, the power light of baby unit turns on.

If the parent unit is out of range of the baby unit, or the baby unit is out of power, the parent unit beeps and its LCD displays **NOT LINKED**.

- Move the parent unit closer to the baby unit.
- Make sure the baby unit is powered on.

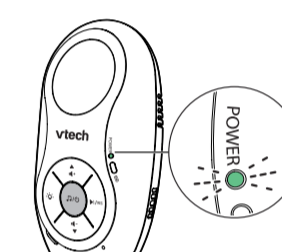

4 POSITIONING THE BABY MONITOR

NOTE

- This audio monitor is intended as an aid. It is not a substitute for proper adult supervision, and should not be used as such.

- CAUTION**
 - Keep the baby unit out of the reach of your baby. Never place or mount the baby unit inside the baby's crib or playpen.

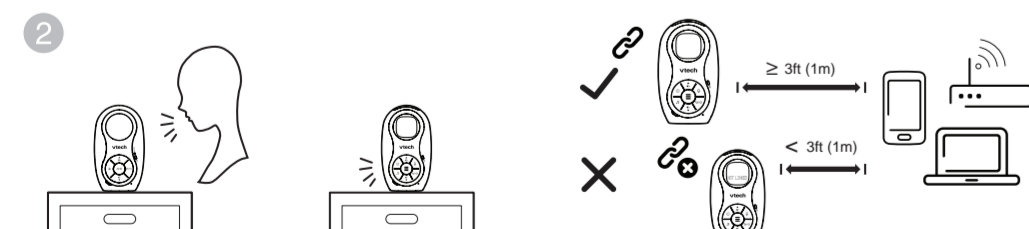
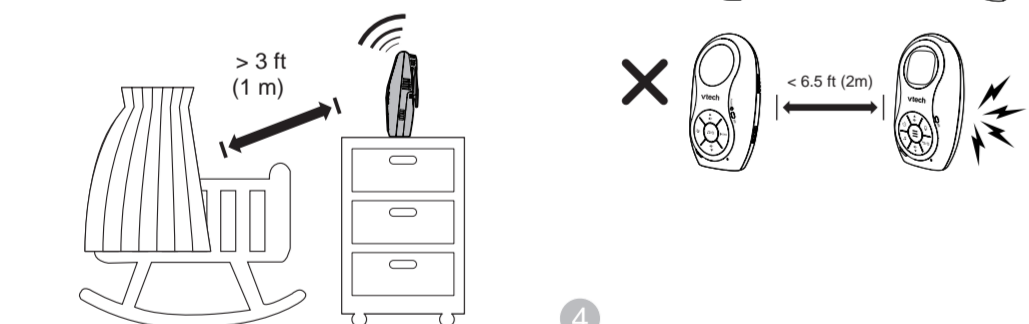

NOTE

- To avoid interference from other electronic devices, place your baby monitor at least 3 feet (1 meter) away from devices such as wireless routers, microwaves, cell phones and computers.

- CAUTION**
 - The default speaker volume of your parent unit is level 3. If you experience high-pitched screeching noise from your baby monitor while positioning:
 - Make sure your baby unit and parent unit are more than 6.5 feet (2 meters) apart, OR
 - Turn down the volume of your parent unit.

BASIC OPERATION - BABY MONITOR

Adjust baby unit and parent unit speaker volumes

Press to adjust your baby unit and parent unit speaker volumes.

Parent unit

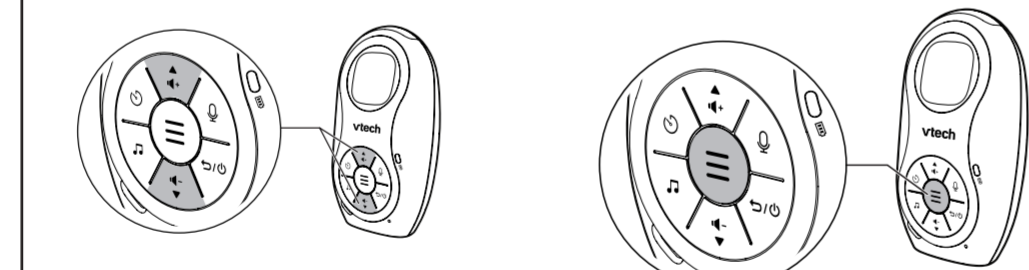

Baby unit

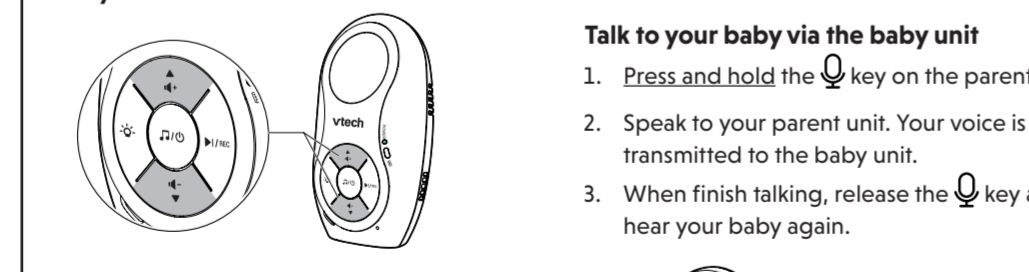

Night light

Press on the baby unit to turn on or off the night light.

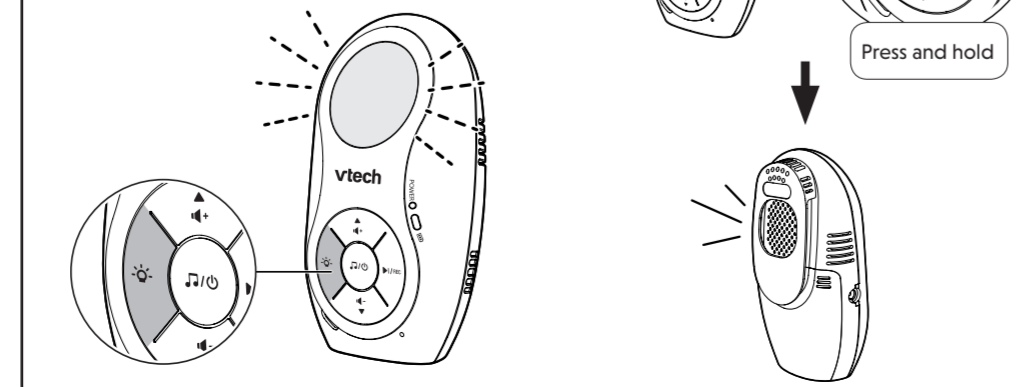

Use the menu

Press to enter the menu, choose a menu item, or save a setting. You can use the parent unit for advanced settings or operations, such as adjust the baby unit sound sensitivity.

Talk to your baby via the baby unit

- Press and hold the key on the parent unit.
- Speak to your parent unit. Your voice is transmitted to the baby unit.
- When finish talking, release the key and hear your baby again.

SET UP ALARM TIMER

Set up countdown alarm

You can set up alarm reminder with the parent unit.

- Press when the parent unit is not in use.
- Press to increase or decrease the countdown timer by 30 minutes with each press. You can set the timer up to the maximum of 24 hours.
- Press or to confirm your selection. The screen displays **SAVED** and you hear a confirmation tone.

NOTES

- You can check the remaining time by pressing when the alarm timer is running.
- Press to reset the timer to 00:00. Press or to return to idle mode.



CHANGE THE FACE PLATE (OPTIONAL)

You parent unit(s) and baby unit each attached with a face plate, and your package include two additional face plates. There are three colors of the face plates - yellow, blue and pink. You can change the unit's face plate for easy identification of the units.

Detach the face plate



Attach the face plate



OVERVIEW - BABY UNIT

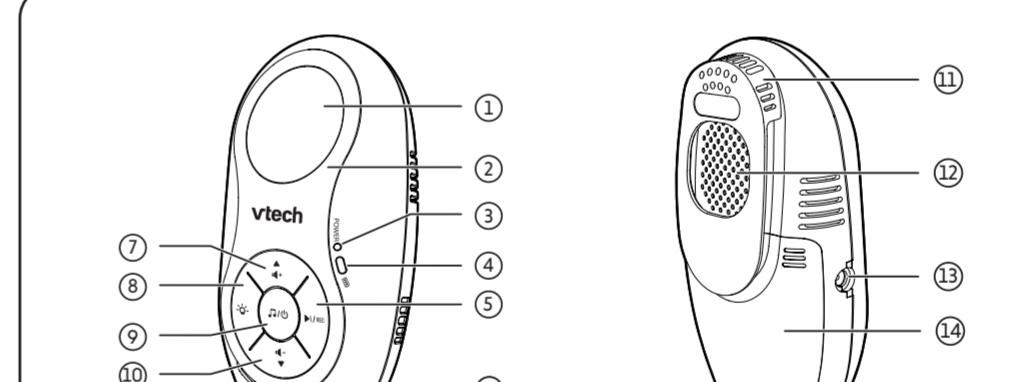

- Night light**
 - On when night light is turned on manually.
 - Off when night light is turned off manually.
- Changeable face plate**
- POWER light**
 - On when the baby unit is powered on.
 - Off when the baby unit has no power.
- Battery indication light**
 - On when the baby unit's batteries are charging.
 - Flashes when the batteries are low and need charging.
- ▶/REC**
 - Press to play the next lullaby.
 - Press and hold to record your own voice for up to 20 seconds. Release when finish recording. The recorded voice will be saved in one of the five lullabies (See **Lullaby** on the next page).
- Microphone**
- ▲/▼**
 - Press to increase the speaker volume (Level 1 to Level 5).
- ☾**
 - Press to turn the night light on or off.
 - Press and hold to adjust the brightness of the night light.
- 🎵/🔊**
 - Press and hold to power on, and the power light turns on.
 - Press and hold to power off, and the power light turns off.
 - When the baby unit is powered on, press to play the selected lullaby or the recorded voice. Press again to stop playing the lullaby or recorded voice.
- ◀**
 - Press to decrease the speaker volume (Level 1 to Level 5).
- Belt clip with temperature sensor**
- Speaker**
- Power jack**
- Battery compartment cover**

OVERVIEW - PARENT UNIT

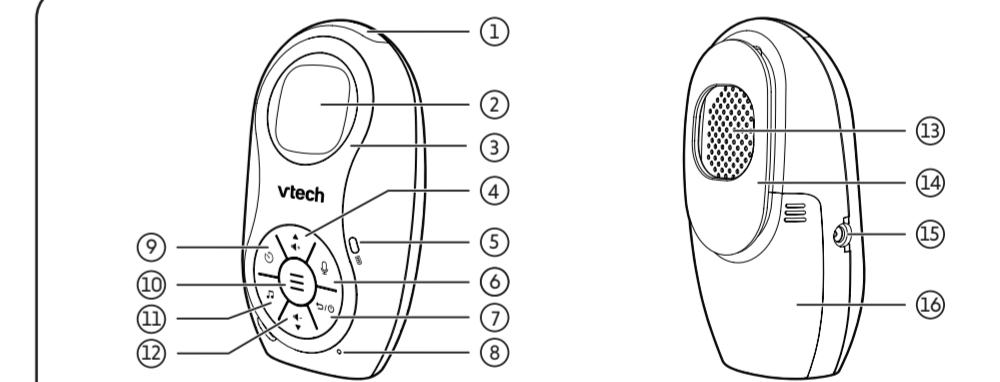















- 3-level sound indicator light**
 - Green on when low sound level is detected by the baby unit.
 - Green and amber on when moderate sound level is detected by the baby unit.
 - Green, amber and red on when high sound level is detected by the baby unit (e.g. baby crying loudly).
- LCD display**
- Changeable face plate**
- ▲**
 - Press to increase the speaker volume (Level 1 to Level 5).
 - While in a menu, press to scroll up.
- Battery indication light**
 - On when the parent unit's batteries are charging.
 - Flashes when the batteries are low and need charging.
- 🔊/🔊**
 - Press to play or stop playing the lullaby or recorded voice.
 - When setting the alarm timer, press to reset the timer to 00:00.
- ▶**
 - Press to enter the menu.
 - While in a menu, press to choose an item, or save a setting.
- 🎵**
 - Press to play or stop playing the lullaby or recorded voice.
 - When setting the alarm timer, press to reset the timer to 00:00.
- ▶**
 - Press to decrease the speaker volume (Level 1 to Level 5).
 - Press repeatedly until the volume reaches the minimum to turn it off.
 - While in a menu, press to scroll down.
- 🔊**
 - Press and hold to power on. Press and hold again to power off.
 - While in a menu, press to return to the previous menu.
- Speaker**
- Belt clip**
- Power jack**
- Battery compartment cover**

☰ MENU TREE



Press **☰** when the parent unit is idle can enter the main menu. Please refer to the following for the menu structure.

| | | |
|------------------|---|--|
| Main menu | Sub-menu | |
| REGION | | <ul style="list-style-type: none"> Choose one of the display languages - English/French/Spanish. |
| SONG | PLAY ALL SONG 1 SONG 2 SONG 3 SONG 4 SONG 5 (SONG 5 is reserved for recorded voice) | <ul style="list-style-type: none"> Play all four lullabies. If you have recorded a voice to the baby unit (up to 20 seconds), it will be stored in SONG 5. Choose one of the four lullabies or the recorded voice to play. Play or stop playing the selected lullaby or the recorded voice. |
| VOX | LV 1 LV 2 LV 3 LV 4 OFF | <ul style="list-style-type: none"> Choose one of the five VOX sensitivity levels. See Sound sensitivity and Sound Alert section. |
| SOUND ALERT | ON? OFF? | <ul style="list-style-type: none"> Turn on or off sound alert. See Sound sensitivity and Sound Alert section. |
| BABY VOLUME | VOL 5 VOL 4 VOL 3 VOL 2 VOL 1 | <ul style="list-style-type: none"> Adjust the baby unit's speaker volume. |
| NIGHT LIGHT | ON? OFF? | <ul style="list-style-type: none"> Turn on or off the night light. |
| RESET | SURE? | <ul style="list-style-type: none"> Reset all parent unit's settings to factory default. |

☰ PARENT UNIT ICONS

| | |
|---|--|
| Status icons | Parent unit display screen messages |
|  <ul style="list-style-type: none"> Connection status <ul style="list-style-type: none">  displays when strong signal strength is detected between the baby unit and the parent unit.  displays when moderate signal strength is detected between the baby unit and the parent unit.  displays when the weak signal strength is detected between the baby unit and the parent unit.  flashes when the link between the baby unit and the parent unit is lost.  <ul style="list-style-type: none"> Displays when the baby unit is playing a lullaby or the recorded voice. | <ul style="list-style-type: none"> NOT LINKED <ul style="list-style-type: none"> The link between the parent unit and the baby unit is lost. TALK <ul style="list-style-type: none"> You are using the parent unit to talk to your baby. HIGH TEMP <ul style="list-style-type: none"> The baby unit detects that the baby room's temperature has risen above 86°F. LOW TEMP <ul style="list-style-type: none"> The baby unit detects that the baby room's temperature has dropped below 50°F. LOW BATT <ul style="list-style-type: none"> The parent unit's batteries are low and need to be recharged. SONG X (Lullaby name) <ul style="list-style-type: none"> One of the lullaby or the record voice is playing. 77°F <ul style="list-style-type: none"> The temperature level detected in the baby's room. |
|  <ul style="list-style-type: none"> Sound alert <ul style="list-style-type: none"> Displays when the sound alert of the parent unit is turned on. Flashes when there are loud sounds detected from the baby unit. | |
|  <ul style="list-style-type: none"> Night light <ul style="list-style-type: none"> Displays when the nigh light is turned on. | |
|  <ul style="list-style-type: none"> Mute <ul style="list-style-type: none"> Displays when the parent unit speaker volume is turned off. | |
|  <ul style="list-style-type: none"> Battery status <ul style="list-style-type: none">    animates when the battery is charging.  displays solid when the battery is fully charged.  displays empty when the battery is in low level and needs charging. No battery icon displays when there is no battery installed. | |

NEED HELP?

| | |
|--|---|
| <p>For latest information and supports, go and check our website.</p> <p>Use your smartphone or mobile device to access our online support.</p> <ul style="list-style-type: none"> Go to https://help.vtechphones.com/dm1215 or https://help.vtechphones.com/dm1215-2, OR Scan the QR code on the right. Launch the camera app or QR code scanner app on your smartphone or tablet. Hold the device's camera up to the QR code and frame it. Tap the notification to trigger the redirection of the online support. <ul style="list-style-type: none"> If the QR code is not clearly displayed, adjust your camera's focus by moving your device closer or further away until it is clear. <p>You can also call our Customer Support at 1 (800) 595-9511 [in US] or 1 (800) 267-7377 [in Canada] for help.</p> |   <p>DM1215</p>  <p>DM1215-2</p> |
|--|---|

☞ GENERAL PRODUCT CARE

To keep this product working well and looking good, follow these guidelines:

- Avoid putting it near heating appliances and devices that generate electrical noise (for example, motors or fluorescent lamps).
- DO NOT expose it to direct sunlight or moisture.
- Avoid dropping the product or treating it roughly.
- Clean with a soft cloth.
- DO NOT immerse the parent unit and the baby unit in water and do not clean them under the tap.
- DO NOT use cleaning spray or liquid cleaners.
- Make sure the parent unit and the baby unit are dry before you connect them to the mains again.

📦 STORAGE

When you are not going to use the baby monitor for some time, store the parent unit, the baby unit and the adapters in a cool and dry place.

DISCLAIMER AND LIMITATION OF LIABILITY

VTech Communications, Inc. and its suppliers assume no responsibility for any damage or loss resulting from the use of this user's manual. VTech Communications, Inc. and its suppliers assume no responsibility for any loss or claims by third parties that may arise through the use of this product.

Company: VTech Communications, Inc.

Address: 9020 SW Washington Square Road - Ste 555 Tigard, OR 97223, United States

Phone: 1 (800) 595-9511 in the U.S. or 1 (800) 267-7377 in Canada

THE RBRC SEAL

The RBRC seal on the Ni-MH battery indicates that VTech Communications, Inc. is voluntarily participating in an industry program to collect and recycle these batteries at the end of their useful lives, when taken out of service within the United States and Canada.

The program provides a convenient alternative to placing used Ni-MH batteries into the trash or municipal waste, which may be illegal in your area.

VTech's participation makes it easy for you to drop off the spent battery at local retailers participating in the program or at authorized VTech product service centers. Please call 1 (800) 8 **BATTERY**® for information on Ni-MH battery recycling and disposal bans/restrictions in your area. VTech's involvement in this program is part of its commitment to protecting our environment and conserving natural resources.

The **RBRC Seal** and **1 (800) 8 BATTERY®** are registered trademarks of Call2recycle, Inc.

FCC AND IC REGULATIONS

FCC Part 15

This equipment has been tested and found to comply with the requirements for a Class B digital device under Part 15 of the Federal Communications Commission (FCC) rules. These requirements are intended to provide reasonable protection against harmful interference in a residential installation. This equipment generates, uses and can radiate radio frequency energy and, if not installed and used in accordance with the instructions, may cause harmful interference to radio communications. However, there is no guarantee that interference will not occur in a particular installation. If this equipment does cause harmful interference to radio or television reception, which can be determined by turning the equipment off and on, the user is encouraged to try to correct the interference by one or more of the following measures:

- Reorient or relocate the receiving antenna.
- Increase the separation between the equipment and receiver.
- Connect the equipment into an outlet on a circuit different from that to which the receiver is connected.
- Consult the dealer or an experienced radio/TV technician for help.

WARNING: Changes or modifications to this equipment not expressly approved by the party responsible for compliance could void the user's authority to operate the equipment.

This device complies with Part 15 of the FCC rules. Operation is subject to the following two conditions: (1) this device may not cause harmful interference, and (2) this device must accept any interference received, including interference that may cause undesired operation.

This Class B digital apparatus complies with Canadian requirement: CAN ICES-3 (B)/NMB-3(B)

Industry Canada

This device contains licence-exempt transmitter(s)/receiver(s) that comply with Innovation, Science and Economic Development Canada's licence-exempt RSS(s). Operation is subject to the following two conditions: (1) This device may not cause interference. (2) This device must accept any interference, including interference that may cause undesired operation of the device.

The term "IC" before the certification/registration number only signifies that the Industry Canada technical specifications were met.

This product meets the applicable Innovation, Science and Economic Development Canada technical specifications.

RF radiation exposure statement

The device has been tested and complies with FCC and IC SAR limits.

CALIFORNIA ENERGY COMMISSION BATTERY CHARGING TESTING MODE

This baby monitor meets the California Energy Commission (CEC) regulations for energy consumption. Your baby monitor is set up to comply with the energy-conserving standards right out of the box. Follow the instructions to install and charge the battery. The CEC battery charging testing mode is activated while charging. Even if the parent unit is paired to baby units, the CEC battery charging testing mode is activated while it is powered off and charging.

🔊 SOUND SENSITIVITY AND SOUND ALERT

Adjust the sound sensitivity of the baby unit
You can choose to hear sounds from the baby unit all the time, or to hear sounds that exceed a certain level. You can use the parent unit to adjust the VOX sensitivity of your baby unit to detect sound. The higher the sensitivity level, the more sensitive the baby unit is in detecting sounds for transmitting to the parent unit. The VOX sensitivity level is preset to **LEVEL 3**.

If you have turned on sound alert, the parent unit beeps when the baby unit detect sounds

| VOX SENSITIVITY LEVEL | Off | Level 4 | Level 3 | Level 2 | Level 1 |
|-----------------------|---|--|---|--|--|
| DESCRIPTION | The parent unit speaker is constantly on, and you will hear all sounds (including background noises) from your baby's room. | The parent unit speaker turns on for soft babbling and louder sounds from your baby. It remains quiet when your baby sleeps soundly. | (Default setting) The parent unit speaker turns on for loud babbling and louder sounds from your baby. It remains quiet when your baby makes soft sounds. | The parent unit speaker turns on for crying and louder sounds from your baby. It remains quiet when your baby makes soft sounds. | The parent unit speaker turns on for loud crying or screeching sounds from your baby. It remains quiet when your baby makes soft sounds. |

- Press **☰** when the parent unit is not in use.
- Press **▲ / ◀+ or ▼ / ▶-** to scroll to **VOX**, then press **☰**.
- Press **▲ / ◀+ or ▼ / ▶-** to choose the VOX sensitivity level.
- Press **☰** to confirm your selection. The screen displays **SAVED** and you hear a confirmation tone.

📖 NOTE

- To enter the **VOX Level** menu of the parent unit, the baby unit must be turned on.

🔊 Sound alert

If you turn on the sound alert, the parent unit beeps when the baby unit detects sounds that exceed the selected VOX sensitivity level.

When the sound alert of the parent unit is turned on,  is shown on LCD display. The sound alert is preset to **OFF**.

- Press **☰** when the parent unit is not in use.
- Press **▲ / ◀+ or ▼ / ▶-** to choose **SOUND ALERT**, then press **☰**. The screen displays **ON?** or **OFF?**.
- Press **☰** to confirm your selection. The screen displays **SAVED** and you hear a confirmation tone.

📖 NOTES

- Press any key on the parent unit to silence the sound alert.
- If you have two parent units, you need to set the sound alert for each unit.
- The parent unit will beep when sound is detected even if the parent unit's speaker volume is muted.

FOR CETL COMPLIANCE ONLY

Mesures de sécurité importantes

- La plaque signalétique appliquée est située au bas du socle de l'unité du bébé.
- Lorsque vous utilisez votre appareil, vous devez toujours suivre certaines mesures de précaution de base afin de réduire les risques d'incendie, d'électrocution et de blessures corporelles, dont ceux qui suivent:
- Observez toutes les instructions et mises en garde inscrites sur l'appareil.
 - L'installation par un adulte est requise.
 - MISE EN GARDE:** N'installez pas l'unité du bébé à une hauteur supérieure à 2 mètres.
 - Ce produit ne remplace pas la surveillance adulte du nourrisson. La supervision du nourrisson est la responsabilité du parent ou de la personne qui s'occupe de l'enfant. Ce produit pourrait cesser de fonctionner et, par conséquent, vous ne devriez pas présumer qu'il continuera de fonctionner correctement pendant une période de temps donnée. De plus, il ne s'agit pas d'un instrument médical et ne devrait pas être utilisé comme tel. Ce produit est destiné à vous aider à superviser votre bébé.
 - N'utilisez pas cet appareil près de l'eau ni de toute autre source d'humidité, par exemple, près d'une baignoire, cuve à lessive, évier de cuisine, dans un sous-sol humide ni près d'une piscine, dans un sous-sol humide ou une douche.
 - MISE EN GARDE:** Utilisez uniquement la pile fournie. Un risque d'explosion pourrait survenir si un mauvais type de pile est utilisé pour l'unité du parent. La pile ne peut pas être soumise à des températures extrêmes élevées ou basses et à une faible pression d'air à haute altitude pendant l'utilisation, l'entreposage ou le transport. L'élimination de la pile dans le feu ou dans un four chaud, ou l'écrasement ou le découpage mécanique de la pile peuvent entraîner une explosion. Laissez la pile dans un environnement à température extrêmement élevée peut entraîner une explosion ou la fuite d'un liquide ou d'un gaz inflammable. Une pile soumise à une pression d'air extrêmement basse peut provoquer une explosion ou une fuite de liquide ou de gaz inflammable. Éliminer la pile usagée conformément aux informations du **Sciau RBRC**.
 - N'utilisez que les adaptateurs inclus avec ce produit. L'utilisation d'un adaptateur dont la polarité ou la tension serait inadéquate risque d'endommager sérieusement le produit et mettre en danger.

 Informations sur les adaptateurs électriques :
Sortie: 6 V CC 400mA.
VTech Telecommunications Ltd.
Modèle : VT05EU506040

 Informations sur les piles rechargeables :
Shenzhen Hipower Technology Co., Ltd. (HF-A-AAA40)
GPI International Limited (VTR-CD43C076)
VIYANG CORUN BATTERY CO., LTD. (NH-AAA40)

- Ne jamais placer le moniteur à l'intérieur du berceau ou du parc de bébé. Ne jamais couvrir le moniteur ou l'unité (s) portative avec un article tel une serviette ou une couverture.
- D'autres équipements électroniques peuvent produire des interférences sur votre moniteur vidéo et audio. Tenez à l'écart d'autres appareils électroniques tels que des routeurs sans fil, radios, téléphones cellulaires, interphones, moniteurs, téléphones, ordinateurs personnels, électromoteurs et téléphones sans fil.
- Stimulateurs cardiaques implantés dans l'organisme**
Les simulateurs cardiaques ne s'applique qu'aux dispositifs numériques sans fil)
L'organisme "Wireless Technology Research, LLC (WTR)", une firme de recherche indépendante, a mené une évaluation pluridisciplinaire des interférences entre les téléphones sans fil portatifs et les simulateurs cardiaques implantés dans l'organisme. Appuyée par l'Administration des aliments et drogues (FDA) des États-Unis, la firme WTR recommande aux médecins:
Avs aux détenteurs de simulateurs cardiaques
 - Vous devez maintenir les dispositifs sans fil à au moins six pouces du simulateur cardiaque.
 - Ils ne doivent PAS placer le téléphone sans fil directement sur le simulateur cardiaque, tel que dans une poche de chemise, lorsque celui-ci est en marche.
L'étude effectuée par l'organisme WRS n'a pas identifié de risque pour les détenteurs de simulateurs cardiaques causés par les gens qui utilisent des dispositifs sans fil à proximité de ceux-ci.
Champs électromagnétiques (EMF)
Ce produit de VTech est conforme à toutes les normes se rapportant aux champs électromagnétiques (EMF) standard. Si vous le manipulez correctement en suivant les instructions de ce guide, son utilisation sera sécuritaire pendant de nombreuses années, selon les meilleures évidences scientifiques dont nous disposons aujourd'hui.

🔊 OPERATIONS

Lullaby

The baby monitor has four lullabies for you to comfort your baby. You can play or stop lullabies on the baby unit by controlling remotely with the parent unit.

If you have recorded a voice to the baby unit (up to 20 seconds), it will be stored in **SONG 5** after the four lullabies.

Play or change lullaby or play recorded voice:

- Press **🎵/🔊** on the baby unit to play or stop playing lullabies or the recorded voice.
- Press **🎵** on the parent unit to play or stop playing lullabies or the recorded voice.

Change lullaby or play the recorded voice using the baby unit:

- Press **▶|/⏮** to browse through all lullabies and the recorded voice, and play.

Play lullaby or the recorded voice using the parent unit:

- Press **☰** when the parent unit is not in use.
- Press **▲ / ◀+ or ▼ / ▶-** to choose **SONG**, then press **☰**.
- Press **▲ / ◀+ or ▼ / ▶-** to choose a lullaby or the recorded voice, or choose **PLAY ALL** to play all four lullabies, then press **☰**. The screen displays **PLAY** or **STOP**.
- Press **☰** to confirm your selection. The screen displays **SAVED** and you hear a confirmation tone.

📖 NOTES

- If you choose a lullaby, the selected lullaby will be played repeatedly for about 15 minutes.
- If **PLAY ALL** is selected, the four lullabies will be played one after the other, until all of them are played.
- When the lullaby or recorded voice is playing, the parent unit screen displays the name of the selected lullaby or displays **SONG 5** when playing the recorded voice. The parent unit displays **PLAY ALL** when playing all four lullabies.
- The lullaby or recorded voice playback on the baby unit will be paused when receiving talkback from the parent unit.

Adjust the speaker volume for baby unit

You can adjust the baby unit's speaker volume from **VOLUME 1** to **VOLUME 5**, using the parent unit.

To adjust the baby unit's speaker volume using the parent unit:

- Press **☰** when the parent unit is not in use.
- Press **▲ / ◀+ or ▼ / ▶-** to choose **BABY VOLUME**, then press **☰**.
- Press **▲ / ◀+ or ▼ / ▶-** to choose your desired volume level, then press **☰**. The screen displays **SAVED** and you hear a confirmation tone.

LIMITED WARRANTY

What does this limited warranty cover?

The manufacturer of this VTech Product warrants to the holder of a valid proof of purchase ("Consumer" or "you") that the Product and all accessories provided in the sales package ("Product") are free from defects in material and workmanship, pursuant to the following terms and conditions, when installed and used normally and in accordance with the Product operating instructions. This limited warranty extends only to the Consumer for Products purchased and used in the United States of America and Canada.

What will VTech do if the Product is not free from defects in materials and workmanship during the limited warranty period ("Materially Defective Product")?

During the limited warranty period, VTech's authorized service representative will repair or replace at VTech's option, without charge, a Materially Defective Product. If we repair the Product, we may use new or refurbished replacement parts. If we choose to replace the Product, we may replace it with a new or refurbished Product of the same or similar design. We will retain defective parts, modules, or equipment. Repair or replacement of the Product, at VTech's option, is your exclusive remedy. VTech will return the repaired or replacement Products to you in working condition. You should expect the repair or replacement to take approximately 30 days.

How long is the limited warranty period?

The limited warranty period for the Product extends for ONE (1) YEAR from the date of purchase. If VTech repairs or replaces a Materially Defective Product under the terms of this limited warranty, this limited warranty also applies to the repaired or replacement Product for a period of either (a) 90 days from the date the repaired or replacement Product is shipped to you or (b) the time remaining on the original one-year warranty, whichever is longer.

What is not covered by this limited warranty?

This limited warranty does not cover:

- Product that has been subjected to misuse, accident, shipping or other physical damage, improper installation, abnormal operation or handling, neglect, inundation, fire, water or other liquid intrusion; or
- Product that has been damaged due to repair, alteration or modification by anyone other than an authorized service representative of VTech; or
- Product to the extent that the problem experienced is caused by signal conditions, network reliability, or cable or antenna systems; or
- Product to the extent that the problem is caused by use with non-VTech accessories; or
- Product whose warranty/quality stickers, product serial number plates or electronic serial numbers have been removed, altered or rendered illegible; or
- Product purchased, used, serviced, or shipped for repair from outside the United States of America or Canada, or used for commercial or institutional purposes (including but not limited to Products used for rental purposes); or
- Product returned without a valid proof of purchase (see item 2 below); or
- Charges for installation or set up, adjustment of customer controls, and installation or repair of systems outside the unit.

Night light

The baby monitor has the night light for you to sooth and comfort your baby at night. You can turn on or off the night light on the baby unit using the parent unit. You can also turn on or off the night light with the baby unit manually.

To turn on or off the night light using the baby unit:

- Press **🌙** to turn on or off the night light.

To turn on or off the night light using the parent unit:

- Press **☰** when the parent unit is not in use.
- Press **▲ / ◀+ or ▼ / ▶-** to choose **NIGHT LIGHT**, then press **☰**. The screen displays **ON?** or **OFF?**.
- Press **☰** to confirm your selection. The screen displays **SAVED** and you hear a confirmation tone.

To adjust the brightness of the night light:

- Press **and hold** **🌙** on the baby unit to change the brightness. Release the **🌙**-key to select and save the brightness setting.

Set default

Use this feature to restore to the default settings.

Restoring default settings is independent for each parent unit if you have two parent units. However, restoring the default settings on one parent unit will also reset the shared settings for VOX sensitivity level of the other parent unit.

- Press **☰** when the parent unit is not in use.
- Press **▲ / ◀+ or ▼ / ▶-** to choose **RESET**, then press **☰**. The screen displays **SURE?**.
- Press **☰** to confirm.

-OR-

Press **↩/🔊** to exit the menu. The current setting remains unchanged.