



AT&T

Quick start guide

BL102/BL102-2/BL102-3/BL102-4/
BL102-5

DECT 6.0 cordless telephone/
answering system with
caller ID/call waiting

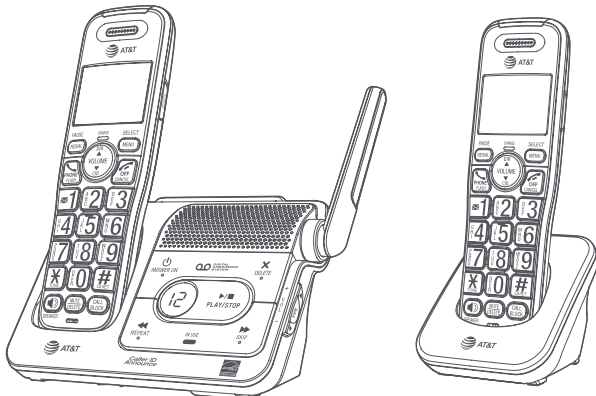

Scan the QR code for
support information



Congratulations

on your purchase of this AT&T product. Before using this AT&T product, please read the **Important safety information** section on pages 1-3 of this manual.

Both the model and serial numbers of your AT&T product can be found on the bottom of the telephone base. Save your sales receipt and original packaging in case it is necessary to return your telephone for warranty service.

For customer service, please visit our website at <https://telephones.att.com> or call **1 (800) 222-3111**.



Please refer to the online **BL102/BL102-2/BL102-3/BL102-4/BL102-5** DECT 6.0 cordless telephone/answering system with **BLUETOOTH®** wireless technology Complete user's manual for a full set of installation and operation instructions at <https://telephones.att.com/manuals>.

Parts checklist

Your telephone package contains the following items.



Quick start guide



Smart call blocker leaflet



Telephone base



Power adapter for telephone base



Cordless handset
(1 for BL102)
(2 for BL102-2)
(3 for BL102-3)
(4 for BL102-4)
(5 for BL102-5)



Charger for cordless handset with power adapter installed
(1 for BL102-2)
(2 for BL102-3)
(3 for BL102-4)
(4 for BL102-5)



Battery for cordless handset
(1 for BL102)
(2 for BL102-2)
(3 for BL102-3)
(4 for BL102-4)
(5 for BL102-5)



Battery compartment cover
(1 for BL102)
(2 for BL102-2)
(3 for BL102-3)
(4 for BL102-4)
(5 for BL102-5)

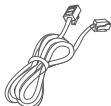

Telephone line cord



Wall-mount bracket

Important safety information



This symbol is to alert you to important operating or servicing instructions that may appear in this user's manual. Always follow basic safety precautions when using this product to reduce the risk of injury, fire, or electric shock.

Safety information

- ▶ Read and understand all instructions in the user's manual. Observe all markings on the product.
- ▶ Avoid using a telephone during a thunderstorm. There may be a slight chance of electric shock from lightning.
- ▶ Do not use a telephone in the vicinity of a gas leak. Under certain circumstances, a spark may be created when the adapter is plugged into the power outlet, or when the handset is replaced in its cradle. This is a common event associated with the closing of any electrical circuit. In an inadequately ventilated environment, the user should not plug the phone into a power outlet, nor put a charged handset into the cradle where there are concentrations of flammable or flame-supporting gases. A spark in such an environment could create a fire or explosion. Such environments might include: medical use of oxygen without adequate ventilation; industrial gases (cleaning solvents; gasoline vapors; etc.); a leak of natural gas; etc.
- ▶ Do not use this product near water or when you are wet. For example, do not use it in a wet basement or shower, nor next to a swimming pool, bathtub, kitchen sink and laundry tub. Do not use liquids or aerosol sprays for cleaning. If the product comes in contact with any liquid, unplug any line or power cord immediately. Do not plug the product back in until it has dried thoroughly.
- ▶ Install this product in a protected location where no one can trip over any line or power cords. Protect cords from damage or abrasion.
- ▶ If this product does not operate normally, see the **Troubleshooting** section of the online Complete user's manual. If you cannot solve the problem, or if the product is damaged, refer to the **Limited warranty** section (pages 29 - 31). Do not open this product except as directed in your user's manual. Opening the product or reassembling it incorrectly may expose you to hazardous voltages or other risks.
- ▶ Replace batteries, only as described in your user's manual (Page 6). Do not burn or puncture batteries — they contain caustic chemicals.
- ▶ This power adapter is intended to be correctly oriented in a vertical or floor mount position. The prongs are not designed to hold the plug in place if it is plugged into a ceiling or an under-the-table/cabinet outlet.
- ▶ For pluggable equipment, the socket-outlet shall be installed near the equipment and shall be easily accessible.



CAUTIONS:

- ▶ Use only the power adapter provided with this product. To obtain a replacement, visit our website at <https://telephones.att.com> or call **1 (800) 222-3111**.

Important safety information



CAUTION: To prevent risk of fire or battery explosion, replace with the correct battery type. Dispose of used batteries according to the instructions.

- ▶ Disconnect the telephone line from the equipment before open the battery door. Do not use the battery in following conditions:
 - ▶ High or low extreme temperature during use, storage or transportation.
 - ▶ Replacement of a battery with an incorrect type that can defeat a safeguard.
 - ▶ Disposal of a battery into fire or a hot oven, or mechanically crushing or cutting of a battery, that can result in an explosion.
 - ▶ Leaving a battery in an extremely high temperature surrounding environment that can result in an explosion or the leakage of flammable liquid or gas.
 - ▶ A battery subjected to extremely low air pressure that can result in an explosion or the leakage of flammable liquid or gas.
- ▶ Use only the supplied rechargeable battery or replacement battery (model BT162342/BT262342). To order, visit our website at **<https://telephones.att.com>**, or call **1 (800) 222-3111**.
- ▶ The applied nameplate is located at the bottom or near of the product.

Especially about cordless telephones

- ▶ **Privacy:** The same features that make a cordless telephone convenient create some limitations. Telephone calls are transmitted between the telephone base and the handset by radio waves, so there is a possibility that your cordless telephone conversations could be intercepted by radio receiving equipment within range of the cordless handset. For this reason, you should not think of cordless telephone conversations as being as private as those on corded telephones.
- ▶ **Electrical power:** The telephone base of this cordless telephone must be connected to a working electrical outlet which is not controlled by a wall switch. Calls cannot be made from the handset if the telephone base is unplugged, switched off or if the electrical power is interrupted.
- ▶ **Potential TV interference:** Some cordless telephones operate at frequencies that may cause interference to TVs and VCRs. To minimize or prevent such interference, do not place the telephone base of the cordless telephone near or on top of a TV or VCR. If interference is experienced, moving the cordless telephone farther away from the TV or VCR will often reduce or eliminate the interference.
- ▶ **Rechargeable batteries:** This product contains nickel-metal hydride rechargeable batteries. Exercise care in handling batteries in order not to create a short circuit with conductive material such as rings, bracelets, and keys. The battery or conductor may overheat and cause harm. Observe proper polarity between the battery and the battery charger.

Important safety information

- ▶ Nickel-metal hydride rechargeable batteries: Dispose of these batteries in a safe manner. Do not burn or puncture. Like other batteries of this type, if burned or punctured, they could release caustic material which could cause injury.



The RBRC Seal means that the manufacturer is voluntarily participating in an industry program to collect and recycle nickel-metal hydride rechargeable batteries when taken out of service within the United States. These batteries may be taken to a participating local retailer of replacement batteries or recycling center. You may call 1-800-8-BATTERY® for locations accepting spent Ni-MH batteries.

The RBRC Seal and 1-800-8-BATTERY® are registered trademarks of Call2recycle, Inc.

Precautions for users of implanted cardiac pacemakers

Cardiac pacemakers (applies only to digital cordless telephones):

Wireless Technology Research, LLC (WTR), an independent research entity, led a multidisciplinary evaluation of the interference between portable wireless telephones and implanted cardiac pacemakers. Supported by the U.S. Food and Drug Administration, WTR recommends to physicians that:

Pacemaker patients:

- ▶ Should keep wireless telephones at least six inches from the pacemaker.
- ▶ Should NOT place wireless telephones directly over the pacemaker, such as in a breast pocket, when it is turned ON.
- ▶ Should use the wireless telephone at the ear opposite the pacemaker.

WTR's evaluation did not identify any risk to bystanders with pacemakers from other persons using wireless telephones.

ECO mode

This power conserving technology reduces power consumption for optimal battery performance. The ECO mode activates automatically whenever the handset is synchronized with the telephone base.

Especially about telephone answering systems

Two-way recording: This unit does not sound warning beeps to inform the other party that the call is being recorded. To ensure that you are in compliance with any federal or state regulations regarding recording a telephone call, you should start the recording process and then inform the other party that you are recording the conversation.

SAVE THESE INSTRUCTIONS

Table of contents

Important safety information	1
Install.....	5
Wall-mount installation (optional)	7
Handset overview	8
Telephone base overview.....	11
Initial basic settings.....	12
Date and time	13
Smart call blocker setup via voice guide.....	13
Basic answering system setup via voice guide.....	13
Record your own announcement.....	14
Number of rings.....	14
Ringer volume.....	14
LCD language	15
Operate.....	15
Directory	16
Bluetooth®.....	16
Pair a Bluetooth cell phone and download the phonebook.....	16
Caller ID.....	18
Caller ID announce.....	18
Review and dial a number in the call log.....	18
Erase missed calls indicator in the call log.....	18
Smart call blocker *§.....	19
Turn Smart call blocker on or off.....	19
Call controls.....	20
Set up allow list, block list and star name list.....	21
Set profile	22
Add a screened number to the block list or allow list.....	22
Block the caller while on a call.....	23
Unblock a telephone number	23
Answering system	24
About answering system and voicemail.....	24
Turn answering system on or off.....	25
Message alert tone.....	25
Call screening.....	25
Message playback.....	26
FCC Part 68 and ACTA.....	27
FCC Part 15.....	28
Limited warranty.....	29
Technical specifications.....	32

Install

Telephone base

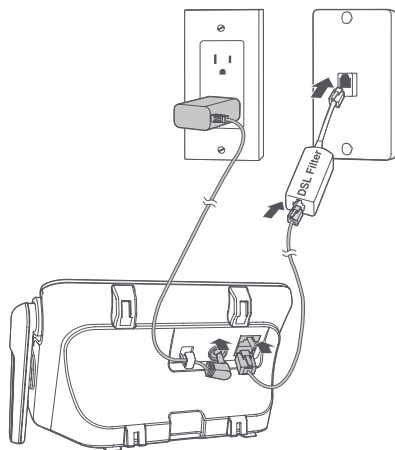

Notes:

- ▶ Plug one end of the telephone line cord into a telephone jack or a DSL filter.
- ▶ If you have DSL high-speed Internet service, a DSL filter (not included) is required.

Charger

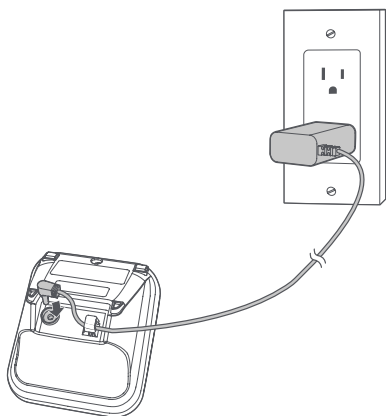

Caution: Use only the power adapter(s) provided with this product. To obtain a replacement, visit our website at

<https://telephones.att.com>
or call **1 (800) 222-3111**.

Install

Battery

Install the battery, as shown below.

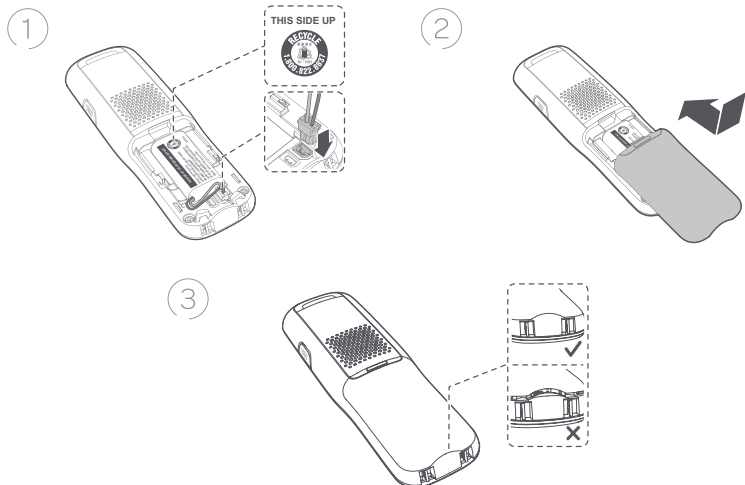

Charge your handset(s) before initial use. The battery is fully charged after 11 hours of continuous charging. The **CHARGE** light on the top of the handset is on during charging.

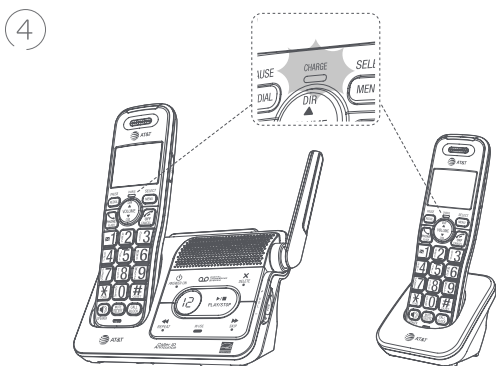

Caution: Use only the supplied rechargeable battery or replacement battery (model BT162342/BT262342).



Wall-mount installation (optional)

- ① Plug the telephone line into the telephone base.

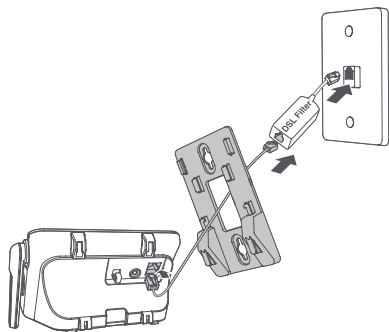

- ② Align the holes on the wall-mount bracket with the standard wall plate and slide the wall-mount bracket down until it locks securely.

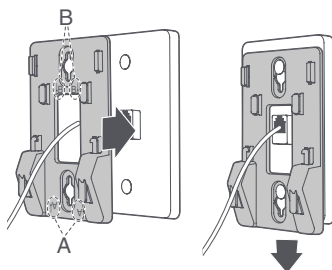

- ③ Insert the extended tabs of the wall-mount bracket into the slots on the back of the telephone base. Push the telephone base down until it is securely in place.

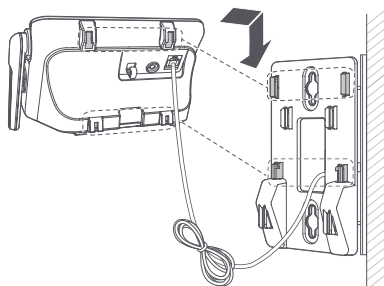

- ④ Plug the power adapter into a power outlet not controlled by a wall switch. Plug the other end of the power adapter into the telephone base.

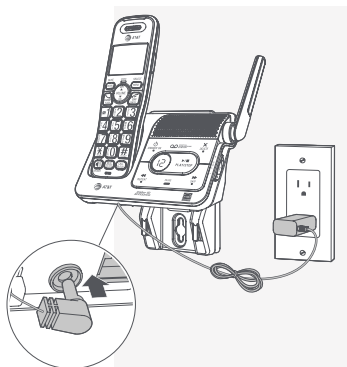



Handset overview

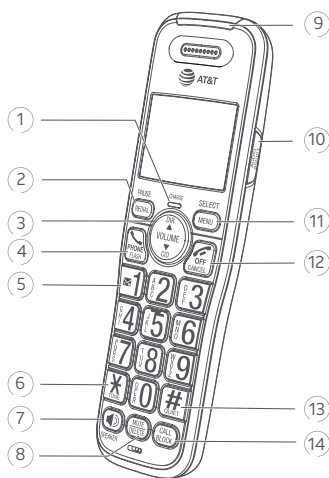

Handset

-
- | | | |
|---|-----------------------------|---|
| ① | CHARGE
indicator | <ul style="list-style-type: none">› On when the handset is charging in the telephone base or charger. |
|---|-----------------------------|---|
-
- | | | |
|---|--------------------------|---|
| ② | REDIAL/
PAUSE | <ul style="list-style-type: none">› Press repeatedly to view the last ten numbers dialed.› <u>Press and hold</u> to insert a dialing pause while entering numbers. |
|---|--------------------------|---|
-
- | | | |
|---|--------------------------|---|
| ③ | ▲ DIR/
VOLUME | <ul style="list-style-type: none">› Press to show directory entries when the handset is not in use.› Press to scroll up while in menus.› Press to move the cursor to the right while entering names or numbers.› Press to increase the listening volume when on a call.› Press to increase the message playback volume. |
|---|--------------------------|---|
-
- | | |
|--------------------------|--|
| ▼ CID/
VOLUME | <ul style="list-style-type: none">› Press to show caller ID log when the handset is not in use.› Press to scroll down while in menus.› Press to move the cursor to the left while entering names or numbers.› Press to decrease the listening volume when on a call.› Press to decrease the message playback volume. |
|--------------------------|--|
-



Handset overview

- | | | |
|---|------------------------------------|--|
| ④ | PHONE/
FLASH | <ul style="list-style-type: none">› Press to make a call.› Press to answer a call.› Press to answer an incoming call when you are on a call and receive a call waiting alert. |
| ⑤ | ✉ 1 | <ul style="list-style-type: none">› While reviewing a caller ID log entry, press repeatedly to add or remove 1 in front of the telephone number before dialing or saving it in the directory.› <u>Press and hold</u> to set or to dial your voicemail number. |
| ⑥ | TONE ✖ | <ul style="list-style-type: none">› Press to switch to tone dialing temporarily during a call if you have pulse service. |
| ⑦ | 🔊/SPEAKER | <ul style="list-style-type: none">› Press to make or answer a call using the speakerphone.› Press to switch between the speakerphone and the handset. |
| ⑧ | MUTE/
DELETE | <ul style="list-style-type: none">› Press to mute the microphone during a call.› Press to mute the ringer temporarily when the handset is ringing.› While reviewing the caller ID log, directory, redial memory, block list, allow list, or star name list, press to delete an individual entry.› Press to delete digits while predialing.› During message playback, press to delete the playing message.› During announcement playback, press to delete the recorded announcement. |
| ⑨ | Visual ringer
indicator | <ul style="list-style-type: none">› Flashes when there is an incoming call. |
| ⑩ | AUDIO
ASSIST® | <ul style="list-style-type: none">› Voices will sound louder and clearer when you press AUDIO ASSIST® while on a call using the handset |
| ⑪ | MENU/
SELECT | <ul style="list-style-type: none">› Press to show menu options.› Press to select an option in the menu.› Press to save an entry or setting. |
-



Handset overview

12

 **OFF/
CANCEL**

- › Press to hang up a call.
 - › Press to cancel an operation.
 - › Press to return to the previous menu.
 - › Press and hold to exit the menu display.
 - › Press to mute the ringer temporarily when the handset is ringing.
 - › Press and hold while the telephone is not in use to erase the missed call indicator.
-

13

**QUIET#
(pound key)**

- › Press repeatedly to display other dialing options when reviewing a caller ID log entry.
 - › Press and hold to enter the **QUIET** mode setting screen, or to deactivate **QUIET** mode.
-

14

CALL BLOCK

- › Press to block the incoming call when the telephone is ringing.
 - › Press to show the call block menu options when the handset is not in use.
 - › During a call, press to block the call.
-



Telephone base overview

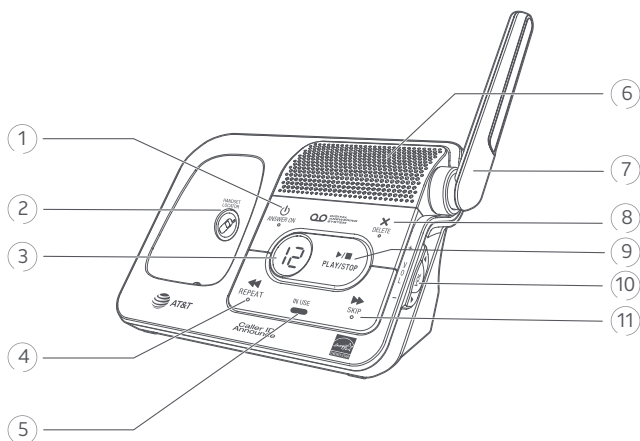

Telephone base

- | | | |
|---|--------------------------|--|
| ① | ⏻/ANSWER ON | ▶ Press to turn the built-in answering system on or off. |
| ② | 📞/HANDSET LOCATOR | ▶ Press to page all handsets. |
| ③ | Message counter | ▶ 1-99 flashes when there are new answering system messages. |
| ④ | ⏮/REPEAT | ▶ Press to repeat the playing message.
▶ Press twice to play the previous message. |
| ⑤ | IN USE indicator | ▶ On when the handset is in use.
▶ On when the answering system is answering an incoming call.
▶ Flashes when another telephone is in use on the same line.
▶ Flashes when there is an incoming call. |
| ⑥ | Speaker) | |
| ⑦ | Antenna | |



Telephone base overview

8	X/DELETE	<ul style="list-style-type: none">› Press to delete the message currently playing.› Press twice to delete all old messages when the phone is not in use.
9	▶/■/PLAY/STOP	<ul style="list-style-type: none">› Press to play messages.› Press to stop message playback.
10	▼VOL▲	<ul style="list-style-type: none">› Press to adjust the volume during message playback.› While the telephone is not in use, press to adjust the base ringer volume.
11	▶/SKIP	<ul style="list-style-type: none">› Press to skip to the next message.



Initial basic settings

After you install your telephone or power returns following a power outage, the handset and telephone base will prompt you to set the date and time. To skip setting the date and time, press  **OFF/CANCEL** on the handset.

Voice guide to set Smart call blocker and answering system

After the date and time setting is done or skipped, the telephone base will prompt if you want to set Smart call blocker. Follow the voice guide to set up the Smart call blocker. To skip the setup, press **DELETE** on the telephone base.

After the Smart call blocker setting is done or skipped, the telephone base will then prompt if you want to set up the answering system. Follow the voice guide to set up the answering system. To skip the setup, press **DELETE** on the telephone base.

We recommend you program your telephone system before use. The following are a few examples of common features to set before using the telephone. Refer to the **Handset and telephone base settings** and **Answering system settings** in the Complete user's manual for detailed instructions on setting all telephone features.



Initial basic settings

Date and time



Note: Set the date/time before using the answering system.

Using a cordless handset or the telephone base:

1. **MENU** -> ▼ / ▲ -> **Set date/time** -> **SELECT**.
2. Enter the month (**MM**), day (**DD**) and year (**YY**) -> **SELECT**.
3. Enter the hour (**HH**) and minute (**MM**).
4. ▼ / ▲ -> **AM** or **PM** -> **SELECT**.

Smart call blocker setup via voice guide

Using the telephone base

After your install your telephone for the first time, the telephone base will prompt if you want to set Smart Call blocker. Follow the voice guide to set or skip the settings.

The telephone base announces, "Hello! This voice guide will assist you with the basic set up of Smart Call blocker...".

- ▶ To screen calls with telephone numbers that are not saved in your directory, allow list or star name list.

-OR-

- ▶ Do not screen calls, and allow all incoming calls to get through.

Listen to the instructions to set up your Smart call blocker.

Basic answering system setup via voice guide

Using the telephone base

After the Smart call blocker setting is done or skipped, the telephone base will then prompt if you want to set up the answering system. Listen to the instructions to set up your answering system.

Stop the voice guide

- ▶ While the voice guide is playing, press **DELETE** on the telephone base.

Restart the voice guide

- ▶ On the telephone base, press the keys in the following sequence.
▶▶/SKIP - ▶▶/SKIP - ▶▶/SKIP - ◀◀/REPEAT - ◀◀/REPEAT - ▶▶/SKIP - ▶/■/PLAY/STOP



Initial basic settings

Record your own announcement

Your outgoing announcement plays when calls are answered by the answering system. You can use the preset announcement to answer calls, or replace it with your own recorded announcement.

Using a cordless handset:

1. **MENU** -> ▼ / ▲ -> **Answering sys** -> **SELECT**.
2. **SELECT** to select **Announcement**.
3. Press **7** to record.
4. Speak towards the handset to record your announcement and press **5** to end recording and save it.

Number of rings

You can set the answering system to answer an incoming call after 2, 3, 4, 5, or 6 rings. You can also select toll saver. If you choose toll saver, the answering system answers a call after two rings when you have new messages, or after four rings when there are no new messages. This enables you to check for new messages and avoid paying unnecessary long distance charges if you are calling from out of your local area.

Using a cordless handset:

1. **MENU** -> ▼ / ▲ -> **Answering sys** -> **SELECT**.
2. ▼ / ▲ -> **Ans sys setup** -> **SELECT**.
3. ▼ / ▲ -> **# of rings** -> **SELECT**.
4. ▼ / ▲ to choose among **2, 3, 4, 5, 6**, or **Toll saver** -> **SELECT**.

Ringer volume

You can set the ringer volume level to one of the six levels, or turn the ringer off. When the ringer is off,  appears on the screen.

Adjust a cordless handset volume:

1. **MENU** -> ▼ / ▲ -> **Ringers** -> **SELECT**.
2. **SELECT** to select **Ringer volume**.
3. ▼ / ▲ to choose the desire level -> **SELECT**.



Note: You can set the volume of each handset individually and differently.

Adjust the telephone base volume:

- ▶ Press ▼ **VOL** ▲ on the base when the phone system is not in use.



Initial basic settings

LCD language

Using a cordless handset:

1. **MENU** -> ▼ / ▲ -> **Settings** -> **SELECT**.
2. **SELECT** again to select **LCD language**.
3. ▼ / ▲ to choose **English, Français** or **Español** -> **SELECT**.



Note: If you accidentally change the LCD language to French or Spanish, you can reset it back to English without going through the French or Spanish menus.

- ▶ Press **MENU** on the handset when it is not in use -> enter ***364#**.





Operate

Operation	Steps
Making a call	▶ Press PHONE/FLASH or SPEAKER -> Enter the telephone number.
On-hook dialing (predialing)	▶ Enter the telephone number -> Press PHONE/FLASH or SPEAKER to call.
Answering a call	▶ Press PHONE/FLASH or SPEAKER .
Ending a call	▶ Press OFF/CANCEL or return the handset to the telephone base or charger.
Handset speakerphone	▶ During a call, press SPEAKER to switch between handsfree speakerphone and normal handset use.
Redial	Using a cordless handset: Press REDIAL repeatedly to select the desired entry -> PHONE/FLASH or SPEAKER to call.
Volume control	Using a cordless handset or the telephone base: Press VOL ▼ to decrease or press VOL ▲ to increase the listening volume during a call.
Call waiting (Requires subscription from telephone)	Press PHONE/FLASH on the handset to put current call on hold and to take the new call.



Directory

The directory can store up to 1,000 entries, including any downloaded phonebook entries from your Bluetooth® cell phone. Directory entries are shared by all system devices.

Operation	Steps
Adding an entry in the directory	<ol style="list-style-type: none">1. MENU -> ▼ / ▲ -> Directory -> SELECT.2. SELECT to select Add new entry.3. Enter a telephone number up to 30 digits -> SELECT.4. Enter a name up to 15 characters -> SELECT.<ul style="list-style-type: none">▶ Press 0 to insert a space.
Searching/dialing an entry	<ol style="list-style-type: none">1. Press ▲ DIR on the handset when it is not in use -> ▼ / ▲ to select the desired directory.2. Press  PHONE/FLASH or  SPEAKER to call.
Adding a caller ID log entry in the directory	<ol style="list-style-type: none">1. ▼ CID -> ▼ / ▲ -> SELECT to select the desired entry.2. SELECT again to select To Directory.3. Edit the telephone number if needed -> SELECT.4. Edit the name if needed -> SELECT.



Pair a Bluetooth cell phone and download the phonebook

Your telephone system is enhanced with Bluetooth feature. You can download up to 1,000 cell phone phonebook entries to your telephone system via Bluetooth wireless technology. Each downloaded entry is stored in the telephone's phonebook with up to 30 digits for phone number and 15 characters for name.

Bluetooth wireless technology operates within a short range (up to 30 feet). Keep the connected device within 15 feet of the telephone base for optimal performance.



The Bluetooth® word mark and logos are owned by Bluetooth SIG, Inc. and any use of such marks by Advanced American Telephones and its parent, VTech Holdings Limited, is under license. VTech Holdings Limited is a member of Bluetooth SIG, Inc. Other trademarks and trade names are those of their respective owners.



Notes:

- ▶ Your **BL102/BL102-2/BL102-3/BL102-4/BL102-5** is compatible with Bluetooth version 2.0 or above devices.
- ▶ Before you begin, make sure that you have cellular coverage and your Bluetooth enabled cell phone is not connected to any other Bluetooth device.
- ▶ Make sure you turn on the Bluetooth feature of your cell phone. Refer to your cell phone user's manual to learn how.

Pair your cell phone and download the phonebook:

1. Place your cell phone next to the telephone base.
2. **Press and hold** /REPEAT on the base for at least 4 seconds. The base will beep once, then shows **Pb** on the display. It enters pairing mode. 
 - ▶ After your cell phone finds your AT&T telephone system (**AT&T DECT 6.0**), press the appropriate key on your cell phone to continue the pairing process.
 - ▶ Once paired, your cell phone may request for the permission of allowing the telephone system (**AT&T DECT 6.0**) to access your cell's phonebook.
3. Permit the request if you wish to continue.

- ▶ The telephone starts downloading, and the base's display animates.

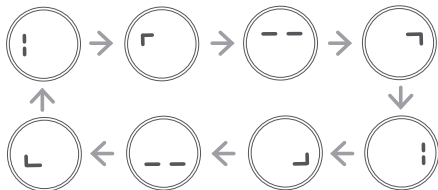

Note: The process may take around 30 minutes, depending on the number of your cell phone phonebook's entries.

4. When the download completes, the base plays a confirmation tone, and its display returns to idle. The base will disconnect from the cell phone.

Cancel the download

- ▶ You can cancel the download by pressing **X/DELETE** on the base.

Restart the download

When error occurs during downloading, the base plays an error tone with 4 beeps. Its display shows **Er** for 5 seconds, then it returns to idle. 

To restart the download:

- ▶ Repeat the process from step 1.



Note: The telephone system will remove any duplicate entries, and any entries that contain unrecognizable symbols; therefore, the number of entries downloaded from your cell phone phonebook may be less than the number of entries stored in your cell phone.

Caller ID

This product supports caller ID services offered by most telephone service providers. The telephone stores caller ID information of the last 50 incoming calls in the telephone base. This information is common to all devices.



Caller ID announce

When this feature is on and you have an incoming call, the handset and/or base speaks “*Call from...*” and the name of the caller based on the directory or caller ID information. If the caller’s name is private or unknown, the phone number up to the last 11 digits will be spoken. If the caller’s phone number is also private or unknown, no information will be spoken.

Using a cordless handset:

1. **MENU** -> ▼ / ▲ -> **Caller ID annnc** -> **SELECT**.
2. ▼ / ▲ to choose **On** or **Off** -> **SELECT**.

Review and dial a number in the call log

1. Press **CID** on the handset when it is not in use -> ▼ / ▲ to scroll through the list.
2. Press  **PHONE/FLASH** or  **SPEAKER** on the handset to dial.
 - ▶ You can press **#** repeatedly to add or remove **1** in the number before dialing.

Erase missed calls indicator in the call log

When you have missed calls, the screen shows **XX Missed calls**.

This is the total number of calls you have not yet reviewed in the call log.

To erase this missed call indicator, you can:

- ▶ Scroll and review the call log one by one, or
- ▶ Press and hold  **OFF/CANCEL** on the handset when it is not in use.



Smart call blocker *§

If you have subscribed to caller ID service, then you can use the Smart call blocker feature to screen incoming calls.



Note: The screening feature of Smart call blocker is applicable to incoming calls.

Turn Smart call blocker on or off

Smart call blocker is set to on, and to allow all incoming calls by default. To turn on or off Smart call blocker:

1. **CALL BLOCK.**
2. **SELECT** to choose **SCB On/Off**.
3. **▼ / ▲** to choose **On** or **Off** -> **SELECT**.



Notes:

- ▶ Smart call blocker is on, once you install your telephone. It allows all incoming calls to get through and ring by default. You can change the Smart call blocker settings to screen incoming calls from numbers or names that are not yet saved in your directory, allow list, block list, or star name list. You can easily add incoming phone numbers to your allow list and block list. This allows you to build up your lists of allowed and blocked numbers, and Smart call blocker will know how to deal with these calls when they come in again.
- ▶ If you turn off Smart call blocker, all incoming calls will ring, including numbers saved in your block list.
- ▶ When QUIET mode is on, and Smart call blocker is on and in screening mode, all screened calls will be sent to the answering system after screening.

* Use of Smart call blocker feature requires subscription of caller ID service.

§ Includes licenced QalTel™ technology.

QalTel™ is a trademark of Truecall Group Limited.



Smart call blocker

Call controls

Call categories		Call control and options
Unwelcome calls	▶ Numbers saved in block list.	The telephone blocks these calls from ringing through.
Welcome calls	▶ Numbers saved in allow list. ▶ Numbers saved in directory. ▶ Numbers not found in block list. ▶ Caller ID names saved in star name list.	The telephone allows these calls to get through and ring.  Note: All incoming calls will get through and ring by default. If you want to block a call, add the number to the block list.
Unknown calls	▶ Calls without numbers <ul style="list-style-type: none">– Numbers that are “out of area” or set to “Private”.	You can select one of the following five profile options for handling all unknown calls. Screen unknown The telephone plays the screening announcement, and then ask the caller to say his/her name before the call rings on your telephone. You can then answer the call, and hear the caller’s name announced. You can decide whether to accept or reject the call, or to forward the call to the answering system. Screen robot The telephone plays the screening announcement, and then ask the caller to press the pound key (#) before the call rings on your telephone. You can then answer the call. Allow unknown (default settings) The telephone allows these calls to get through and ring. The caller’s number, even if it is available, will not be saved to the allow list. Unknown to answering system The telephone forwards these calls to the answering system without ringing. Block unknown The telephone rejects these calls with block announcement without ringing. The caller’s number, even if it’s available, will not be saved to the block list.
	▶ Uncategorized calls <ul style="list-style-type: none">– With absent caller ID number.– Numbers not found in directory.– Numbers not found in allow list.– Numbers not found in block list.– With caller ID names not found in star name list	



Smart call blocker

Set up allow list, block list and star name list

Add numbers from caller ID log

Adding CID log entry to block list	<ol style="list-style-type: none">1. Press CID on the handset -> ▼ / ▲ .2. Press SELECT when the desired entry appears.3. ▼ or ▲ -> To Block list -> SELECT.4. Press SELECT twice.
Adding CID log entry to allow list	<ol style="list-style-type: none">1. Press CID on the handset -> ▼ / ▲ .2. Press SELECT when the desired entry appears.3. ▼ or ▲ -> To Allow list -> SELECT.4. Press SELECT twice.
Adding CID log entry to star name list	<ol style="list-style-type: none">1. Press CID on the handset -> ▼ / ▲ .2. Press SELECT when the desired entry appears.3. ▼ or ▲ -> To Star name list -> SELECT.4. Press SELECT twice.

Add numbers manually

Adding a new number to the block list	<ol style="list-style-type: none">1. CALL BLOCK.2. ▼ or ▲ -> Block list -> SELECT.3. ▼ or ▲ -> Add new entry -> SELECT.4. Enter a telephone number up to 30 digits -> SELECT.5. Enter a name up to 15 characters -> SELECT.
Adding a new number to the allow list	<ol style="list-style-type: none">1. CALL BLOCK.2. ▼ or ▲ -> Allow list -> SELECT.3. ▼ or ▲ -> Add new entry -> SELECT.4. Enter a telephone number up to 30 digits -> SELECT.5. Enter a name up to 15 characters -> SELECT.
Adding a new name to the star name list	<ol style="list-style-type: none">1. CALL BLOCK.2. ▼ or ▲ -> Star name list -> SELECT.3. ▼ or ▲ -> Add new entry -> SELECT.4. Enter a name up to 15 characters -> SELECT.



Smart call blocker

Set profile

There are five profile setting options, which allows you to quickly set up Smart call blocker.

Set profile	Steps
Screen unknown Screen all unknown calls	1. CALL BLOCK -> ▼ or ▲ -> Set profile -> SELECT . 2. ▼ or ▲ -> Screen unknown -> SELECT .
Screen robot Screen robocalls	1. CALL BLOCK -> ▼ or ▲ -> Set profile -> SELECT . 2. ▼ or ▲ -> Screen robot -> SELECT .
Allow unknown Block calls on the block list only (default settings)	1. CALL BLOCK -> ▼ or ▲ -> Set profile -> SELECT . 2. ▼ or ▲ -> Allow unknown -> SELECT .
UnknownToAns.S Forward all unknown calls to the answering system	1. CALL BLOCK -> ▼ or ▲ -> Set profile -> SELECT . 2. ▼ or ▲ -> UnknownToAns.S -> SELECT .
Block unknown Block all unknown calls	1. CALL BLOCK -> ▼ or ▲ -> Set profile -> SELECT . 2. ▼ or ▲ -> Block unknown -> SELECT .

Add a screened number to the block list or allow list

If you select **Screen unknown** or **Screen robot** in **Set profile**, the telephone plays a screening announcement to the caller, and asks the caller to respond before the call rings through to you. After the caller responds, the telephone rings and you can then pick up the call. The telephone then asks whether you want to answer or reject the call, or to forward the call to the answering system. The telephone announces "To answer the call, press 1. To answer and always allow this number, press 2. To block this number, press 3. To send this call to the answering system, press 4. To repeat these options, press *".



Smart call blocker

You can add a screened number to the block list or to the allow list.

Add current number to the allow list	▶ Press 2 to answer the call, and add the current number to the allow list.
Add current number to the block list	▶ Press 3 to block the call, and add the current number to the block list.



Notes

- ▶ Unknown calls without caller ID information will not have the option 2, “answer and always allow this number”, and option 3, “to block this number”. No number will be added to the allow list or block list for these calls.
- ▶ If you do not want to take the call, press **CANCEL** to end the call.

Block the caller while on a call

When you are on a call and speaking to the caller, and you do not want to continue the call, you can end the call with block announcement and add the number to the block list.

1. During a call, press **CALL BLOCK**.
2. Press **SELECT** to end the call.



Notes

- ▶ The allow list stores up to 200 entries, the block list stores up to 1,000 entries, and the star name list stores up to 10 names.
- ▶ There are many organizations like schools, medical offices, and pharmacies that use robocalls to communicate important information to you. Robocall uses an autodialer to deliver pre-recorded messages. By entering the name of the organizations into the star name list, it ensures these calls will ring through when you only know the caller names but not their numbers.

Unblock a telephone number

If you have added a telephone number to the block list, you can unblock it.

1. Press **CALL BLOCK**.
2. ▼ or ▲ -> **Block list** -> **SELECT**.
3. Press **SELECT** to select **Review**.
4. ▼ or ▲ to browse through the block entries.
5. When the desired entry displays, press **DELETE**, then press **SELECT** to confirm.

ⓄⓄ Answering system

About answering system and voicemail

Your telephone has separate indicators for two different types of voice messages: those left on the built-in answering system and those left at your telephone service provider's voicemail. To listen to messages recorded on the built-in answering system, refer to the **Message playback** section; to listen to voicemail, contact your telephone service provider for more information.

	Built-in answering system ▶/■	Voicemail service ✉
Supported by	Telephone system	Telephone service provider
Subscription	No	Yes
Fees	No	May apply
Answer incoming calls	<ul style="list-style-type: none"> ▶ After 3 rings by default. ▶ It can be changed in the handset or the telephone base menu. 	<ul style="list-style-type: none"> ▶ Usually after 2 rings. ▶ It can be changed by contacting your telephone service provider.
Storage	Telephone base	Server or System
Display new messages	<ul style="list-style-type: none"> ▶ Handset and telephone base - XX New messages 	<ul style="list-style-type: none"> ▶ Handset and telephone base - ✉ and New voicemail
Retrieve messages	<ul style="list-style-type: none"> ▶ Press ▶/■ on the telephone base; OR ▶ Press MENU, and then select Play messages on the handset; OR ▶ Access remotely with an access code. 	<ul style="list-style-type: none"> ▶ <u>Press and hold</u> ✉ on the dialpad, and enter an access number from your telephone service provider; OR ▶ <u>Press and hold</u> ✉ to dial if you have saved the access number.

☉☉ Answering system

Turn answering system on or off

The answering system must be turned on to answer and record messages.

Using the telephone base:

- ▶ Press **⏻/ANSWER ON** to turn the answering system on or off. If the answering system is turned on, it announces, "Calls will be answered." If the answering system is turned off, it announces, "Calls will not be answered."

Using a cordless handset:

1. **MENU** -> **▼ / ▲** -> **Answering sys** -> **SELECT**.
2. **▼ / ▲** -> **Answer on/off** -> **SELECT**.
3. **▼ / ▲** to choose **On** or **Off**-> **SELECT**.

When the answering system is on, the handset shows **ANS ON**.

Message alert tone

When this feature is on, and there is at least one new message, the telephone base beeps every 10 seconds.

Using a cordless handset:

1. **MENU** -> **▼ / ▲** -> **Answering sys** -> **SELECT**.
2. **▼ / ▲** -> **Ans sys setup** -> **SELECT**.
3. **▼ / ▲** -> **Msg alert tone** -> **SELECT**.
4. **▼ / ▲** to choose **On** or **Off** -> **SELECT**.

Call screening

Turn this feature on if you want to listen to the incoming messages when they are being recorded. While monitoring an incoming message, you can answer the call by pressing **PHONE/FLASH** on the handset.

Using a cordless handset:

1. **MENU** -> **▼ / ▲** -> **Answering sys** -> **SELECT**.
2. **▼ / ▲** -> **Ans sys setup** -> **SELECT**.
3. **SELECT** to select **Call screening**.
4. **▼ / ▲** to choose **On** or **Off** -> **SELECT**.

Ⓞ Ⓞ Answering system

Message playback

Using the telephone base:

- › Press ►/■/PLAY/STOP when the telephone base is not in use.

Using a cordless handset:

- › Press **MENU** then **SELECT** when the handset is not in use.

Options during playback

Feature	On the telephone base	On a handset
Adjust playback to volume	Press ▼ VOL ▲	Press VOL ▼ or VOL ▲
Stop playback	Press ►/■/PLAY/STOP	Press  OFF/CANCEL
Skip to the next message	Press ►►/SKIP	Press 6
Repeat the message	Press ◀◀/REPEAT	Press 4
Play the previous message	Press ◀◀/REPEAT twice	Press 4 twice
Delete the message	Press X/DELETE	Press MUTE/DELETE

FCC Part 68 and ACTA

This equipment complies with Part 68 of the FCC rules and with technical requirements adopted by the Administrative Council for Terminal Attachments (ACTA). The label on the back or bottom of this equipment contains, among other things, a product identifier in the format US:AAAEQ##TXXXX. This identifier must be provided to your telephone service provider upon request.

The plug and jack used to connect this equipment to premises wiring and the telephone network must comply with the applicable Part 68 rules and technical requirements adopted by ACTA. A compliant telephone cord and modular plug is provided with this product. It is designed to be connected to a compatible modular jack that is also compliant. An RJ11 jack should normally be used for connecting to a single line and an RJ14 jack for two lines. See the installation instructions in the user's manual.

The Ringer Equivalence Number (REN) is used to determine how many devices you may connect to your telephone line and still have them ring when you are called. The REN for this product is encoded as the 6th and 7th characters following the US: in the product identifier (e.g., if ## is 03, the REN is 0.3). In most, but not all areas, the sum of all RENs should be five (5.0) or less. For more information, please contact your telephone service provider.

This equipment must not be used with Party Lines. If you have specially wired alarm dialing equipment connected to your telephone line, ensure the connection of this equipment does not disable your alarm equipment. If you have questions about what will disable the alarm equipment, consult your telephone service provider or a qualified installer.

If this equipment is malfunctioning, it must be unplugged from the modular jack until the problem has been corrected. Replacement to this telephone equipment can only be made by the manufacturer or its authorized agents. For replacement procedures, follow the instructions outlined under the Limited warranty.

If this equipment is causing harm to the telephone network, the telephone service provider may temporarily discontinue your telephone service. The telephone service provider is required to notify you before interrupting service. If advance notice is not practical, you will be notified as soon as possible. You will be given the opportunity to correct the problem and the telephone service provider is required to inform you of your right to file a complaint with the FCC. Your telephone service provider may make changes in its facilities, equipment, operation, or procedures that could affect the proper functioning of this product. The telephone service provider is required to notify you if such changes are planned.

If this product is equipped with a corded or cordless handset, it is hearing aid compatible.

If this product has memory dialing locations, you may choose to store emergency telephone numbers (e.g., police, fire, medical) in these locations. If you do store or test emergency numbers, please:

- ▶ Remain on the line and briefly explain the reason for the call before hanging up.
- ▶ Perform such activities in off-peak hours, such as early morning or late evening.

FCC Part 15

NOTE: This equipment has been tested and found to comply with the requirements for a Class B digital device under Part 15 of the Federal Communications Commission (FCC) rules. These requirements are intended to provide reasonable protection against harmful interference in a residential installation. This equipment generates, uses and can radiate radio frequency energy and, if not installed and used in accordance with the instructions, may cause harmful interference to radio communications. However, there is no guarantee that interference will not occur in a particular installation. If this equipment does cause harmful interference to radio or television reception, which can be determined by turning the equipment off and on, the user is encouraged to try to correct the interference by one or more of the following measures:

- ▶ Reorient or relocate the receiving antenna.
- ▶ Increase the separation between the equipment and receiver.
- ▶ Connect the equipment into an outlet on a circuit different from that to which the receiver is connected.
- ▶ Consult the dealer or an experienced radio/TV technician for help.

WARNING: Changes or modifications to this equipment not expressly approved by the party responsible for compliance could void the user's authority to operate the equipment.

This device complies with Part 15 of the FCC Rules. Operation is subject to the following two conditions: (1) this device may not cause harmful interference, and (2) this device must accept any interference received, including interference that may cause undesired operation. Privacy of communications may not be ensured when using this telephone.

To ensure safety of users, the FCC has established criteria for the amount of radio frequency energy that can be safely absorbed by a user or bystander according to the intended usage of the product. This product has been tested and found to comply with the FCC criteria. The handset may be safely held against the ear of the user. The telephone base shall be installed and used such that parts of the user's body other than the hands are maintained at a distance of approximately 20 cm (8 inches) or more.

Limited warranty

The AT&T brands are used under license. This product is covered by a one-year limited warranty. Any replacement or warranty service, and all questions about this product, should be directed to our website at

<https://telephones.att.com> or call **1 (800) 222-3111**.

1. What does this limited warranty cover?

The manufacturer of this AT&T Product, Advanced American Telephones, warrants to the holder of a valid proof of purchase (“Consumer” or “you”) that the Product and all accessories provided by Advanced American Telephones in the sales package (“Product”) are free from material defects in material and workmanship, pursuant to the following terms and conditions, when installed and used normally and in accordance with operation instructions. This limited warranty extends only to the Consumer for Products purchased and used in the United States of America.

2. What will Advanced American Telephones do if the Product is not free from material defects in materials and workmanship during the limited warranty period (“Materially Defective Product”)?

During the limited warranty period, Advanced American Telephones’ authorized service representative will replace, at Advanced American Telephones’ option, without charge, a Materially Defective Product. If we choose to replace this Product, we may replace it with a new or refurbished Product of the same or similar design. Advanced American Telephones will return replacement Products to you in working condition.

Advanced American Telephones will retain defective parts, modules, or equipment. Replacement of Product, at Advanced American Telephones’ option, is your exclusive remedy. You should expect the replacement to take approximately 30 days.

3. How long is the limited warranty period?

The limited warranty period for SynJ® and Syn248® products is TWO (2) YEARS from the date of purchase, while all other products limited warranty period is ONE (1) YEAR from the date of purchase. If we replace a Materially Defective Product under the terms of this limited warranty, this limited warranty also applies to replacement Products for a period of either (a) 90 days from the date the replacement Product is shipped to you or (b) the time remaining on the original one-year limited warranty, whichever is longer.

4. What is not covered by this limited warranty?

This limited warranty does not cover:

- ▶ Product that has been subjected to misuse, accident, shipping or other physical damage, improper installation, abnormal operation or handling, neglect, inundation, fire, water or other liquid intrusion; or

- ▶ Product that has been damaged due to repair, alteration or modification by anyone other than an authorized service representative of Advanced American Telephones; or
- ▶ Product to the extent that the problem experienced is caused by signal conditions, network reliability or cable or antenna systems; or
- ▶ Product to the extent that the problem is caused by use with non-Advanced American Telephones electrical accessories; or
- ▶ Product whose warranty/quality stickers, Product serial number plates or electronic serial numbers have been removed, altered or rendered illegible; or
- ▶ Product purchased, used, serviced, or shipped for repair from outside the United States, or used for commercial or institutional purposes (including but not limited to Products used for rental purposes); or
- ▶ Product returned without valid proof of purchase (see item 6); or
- ▶ Charges for installation or set up, adjustment of customer controls, and installation or repair of systems outside the unit.

5. How do you get warranty service?

To obtain warranty service in the United States of America, visit

<https://telephones.att.com> or call **1 (800) 222-3111**.

NOTE: Before calling for service, please check the user's manual. A check of the Product controls and features may save you a service call.

Except as provided by applicable law, you assume the risk of loss or damage during transit and transportation and are responsible for delivery or handling charges incurred in the transport of Product(s) to the service location. Advanced American Telephones will return replaced Product under this limited warranty to you, transportation, delivery or handling charges prepaid. Advanced American Telephones assumes no risk for damage or loss of the Product in transit.

6. What must you return with the PRODUCT to get warranty service?

- ▶ Return the entire original package and contents including the Product to the Advanced American Telephones service location along with a description of the malfunction or difficulty;
- ▶ Include "valid proof of purchase" (sales receipt) identifying the Product purchased (Product model) and the date of purchase or receipt; and
- ▶ Provide your name, complete and correct mailing address and telephone number.

7. Other limitations

This warranty is the complete and exclusive agreement between you and Advanced American Telephones. It supersedes all other written or oral communications related to this Product. Advanced American Telephones provides no other warranties for this Product. The warranty exclusively describes all of Advanced American Telephones' responsibilities regarding the Product. There are no other express warranties. No one is authorized to make modifications to this limited warranty and you should not rely on any such modification.

State/Provincial Law Rights: This warranty gives you specific legal rights, and you may also have other rights which vary from state to state.

Limitations: Implied warranties, including those of fitness for a particular purpose and merchantability (an unwritten warranty that the Product is fit for ordinary use) are limited to one year from date of purchase. Some states/provinces do not allow limitations on how long an implied warranty lasts, so the above limitation may not apply to you.

In no event shall Advanced American Telephones be liable for any indirect, special, incidental, consequential, or similar damages (including, but not limited to lost profits or revenue, inability to use the Product, or other associated equipment, the cost of substitute equipment, and claims by third parties) resulting from the use of this Product. Some states/provinces do not allow the exclusion or limitation of incidental or consequential damages, so the above limitation or exclusion may not apply to you.

Please retain your original sales receipt as proof of purchase.

Technical specifications

RF frequency band	1921.536MHz — 1928.448MHz	
Channels	5	
Telephone base voltage (AC voltage, 60Hz)	96 — 130 Vrms	
	Telephone base voltage (DC adapter output)	6VDC @0.4A
	Charger voltage (AC adapter output)	6VDC @0.4A
Handset voltage	2.4 VDC— 2.8VDC	
Operating times*	Talk time (handset): up to 10 hours Standby: up to 6 days	

* Operating times vary depending on your actual use and the age of the battery.

Company: Advanced American Telephones

Address: 9020 SW Washington Square Road - Ste 555 Tigard, OR 97223, United States.

Phone: 1 (800) 222-3111 in the U.S.



Telephones identified with this logo have reduced noise and interference when used with most T-coil equipped hearing aids and cochlear implants. The TIA-1083 Compliant Logo is a trademark of the Telecommunications Industry Association. Used under license.



The ENERGY STAR® program (www.energystar.gov) recognizes and encourages the use of products that save energy and help protect our environment. We are proud to supply this product with an ENERGY STAR® qualified power adapter meeting the latest energy efficiency guidelines.

The Bluetooth® word mark and logos are owned by Bluetooth SIG, Inc. and any use of such marks by Advanced American Telephones and its parent, VTech Holdings Limited, is under license. VTech Holdings Limited is a member of Bluetooth SIG, Inc. Other trademarks and trade names are those of their respective owners.

©2020-2023 Advanced American Telephones. All Rights Reserved.

AT&T and the AT&T logo are trademarks of AT&T Intellectual Property licensed to Advanced American Telephones, San Antonio, TX 78219.

Qaltel™ is a trademark of Truecall Group Limited.

Audio Assist® is a registered trademark of Advanced American Telephones.

SynJ® and Syn248® are trademarks of Advanced American Telephones.

The RBRC Seal and 1-800-8-BATTERY® are registered trademarks of Call2recycle, Inc.

Printed in China. Issue 9.0 AT&T 03/23.

Product code: HSDE59-BSDCX81_BT_Y