

**Test Report:** 1W03875  
Issue: 2.0

**Applicant:** VTECH Engineering Canada  
200-7671 Alderbridge Way  
Richmond, BC  
V6X 1Z9

**Equipment Under Test:  
(EUT)** AT&T 2230  
2.4GHz FHSS Cordless Telephone

**In Accordance With:** **FCC Part 15, Subpart C**  
Frequency Hopping Transmitters  
2400 - 2483.5 MHz

**Tested By:** Nemko Canada Inc.  
(Formerly KTL Ottawa Inc.)  
3325 River Road, R.R. 5  
Ottawa, Ontario K1V 1H2

**Authorized By:**  
  
R. Grant, Wireless Group Manager

**Date:**

**Total Number of Pages:** 70

**Table of Contents**

**Section 1. Summary of Test Results..... 3**

**Section 2. General Equipment Specification ..... 5**

**Section 3. Powerline Conducted Emissions ..... 8**

**Section 4. Channel Separation..... 12**

**Section 5. Pseudorandom Hopping Algorithm..... 15**

**Section 6. Time of Occupancy ..... 31**

**Section 7. Occupied Bandwidth..... 36**

**Section 8. Peak Power Output..... 43**

**Section 9. Spurious Emissions (Radiated)..... 50**

**Section 10. Test Equipment List ..... 70**

**Annex A Block Diagrams..... A1**

*EQUIPMENT: AT&T 2230, 2.4GHz FHSS Cordless Telephone*  
*ISSUE: 2.0*

---

## **Section 1. Summary of Test Results**

### **General**

**All measurements are traceable to national standards.**

These tests were conducted on a sample of the equipment for the purpose of demonstrating compliance with Part 15, Subpart C, Paragraph 15.247 for Frequency Hopping Spread Spectrum devices. Radiated tests were conducted in accordance with ANSI C63.4-1992. Radiated emissions are made on an open area test site. A description of the test facility is on file with the FCC.

New Submission

Production Unit

Class II Permissive Change

Pre-Production Unit

D	S	S
---	---	---

Equipment Code

Family Listing

**THIS TEST REPORT RELATES ONLY TO THE ITEM(S) TESTED.**

**THE FOLLOWING DEVIATIONS FROM, ADDITIONS TO, OR EXCLUSIONS FROM THE TEST SPECIFICATIONS HAVE BEEN MADE.**

See " Summary of Test Data".



**NVLAP LAB CODE: 100351-0**

TESTED BY: \_\_\_\_\_ DATE: \_\_\_\_\_  
Glen Westwell, Wireless Technologist

Nemko Canada Inc. authorizes the above named company to reproduce this report provided it is reproduced in its entirety and for use by the company's employees only.

Any use which a third party makes of this report, or any reliance on or decisions to be made based on it, are the responsibility of such third parties. Nemko Canada Inc. accepts no responsibility for damages, if any, suffered by any third party as a result of decisions made or actions based on this report. This report applies only to the items tested.

*EQUIPMENT: AT&T 2230, 2.4GHz FHSS Cordless Telephone*  
*ISSUE: 2.0*

---

**Summary Of Test Data**

<b>Name Of Test</b>	<b>Para. No.</b>	<b>Result</b>
Powerline Conducted Emissions	15.207(a)	Complies
Channel Separation	15.247(a)(1)	Complies
Pseudorandom Hopping Algorithm	15.247(a)(1)	Complies
Time of Occupancy	15.247(a)(1)(ii)	Complies
20 dB Occupied Bandwidth	15.247(a)(1)	Complies
Peak Power Output	15.247(b)	Complies
Spurious Emissions (Radiated)	15.247(c)	Complies

**Footnotes For N/A's:**

**Test Conditions:**

**Indoor**                      Temperature: 22 °C  
   Humidity: 31 %

**Outdoor**                     Temperature: 18 °C  
   Humidity: 39 %







*EQUIPMENT: AT&T 2230, 2.4GHz FHSS Cordless Telephone*  
*ISSUE: 2.0*

---

**Section 3. Powerline Conducted Emissions**

**Para. No.: 15.207 (a)**

<b>Test Performed By:</b> Glen Westwell	<b>Date of Test:</b> May 11, 2001
---	-----------------------------------

**Test Results:** Complies. See attached graph.

**Measurement Data:** See attached graph.



EQUIPMENT: AT&T 2230, 2.4GHz FHSS Cordless Telephone  
ISSUE: 2.0

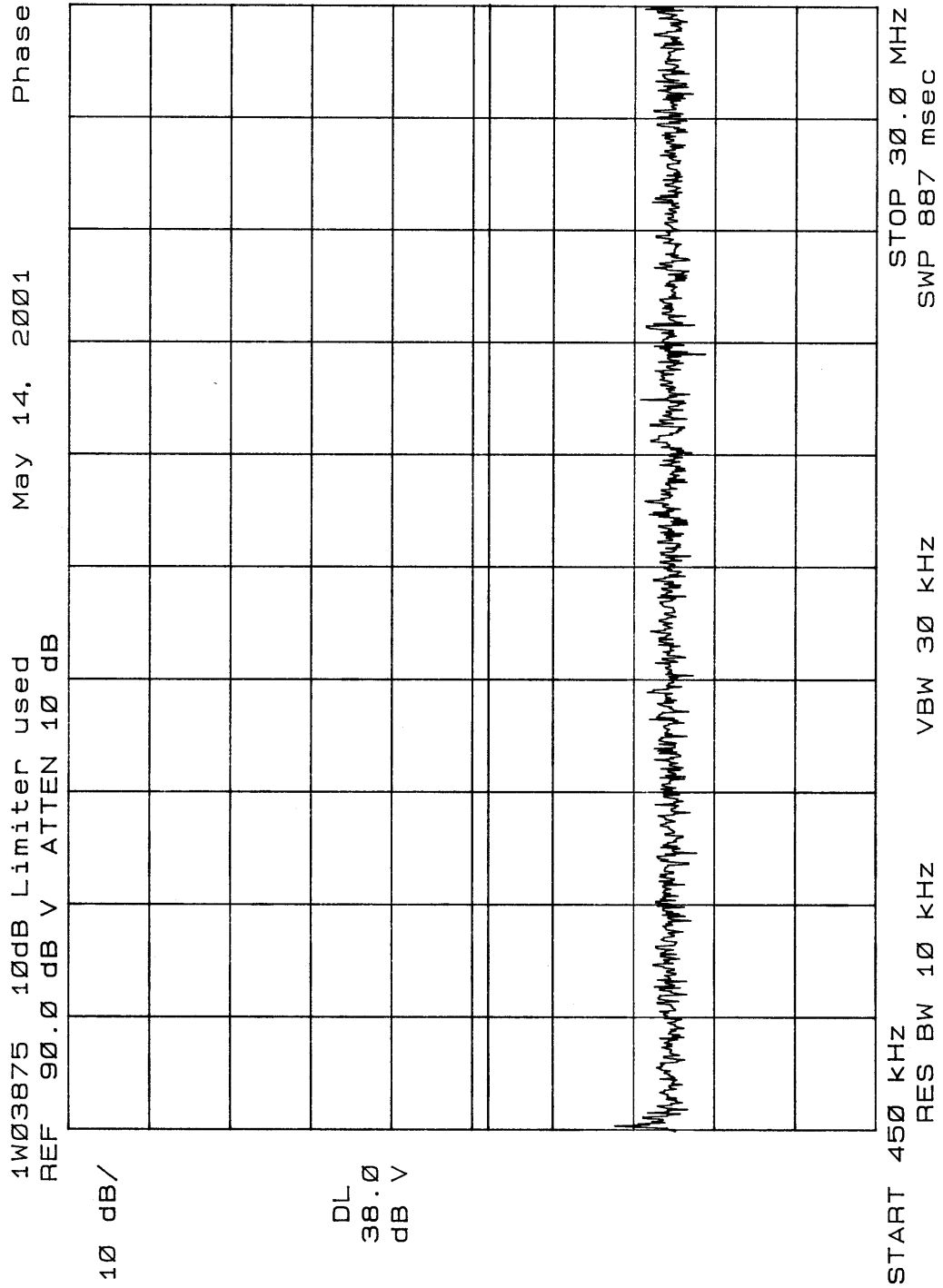



*EQUIPMENT: AT&T 2230, 2.4GHz FHSS Cordless Telephone*  
*ISSUE: 2.0*

---

**Conducted Photographs (Worst Case Configuration)**

**Side View**

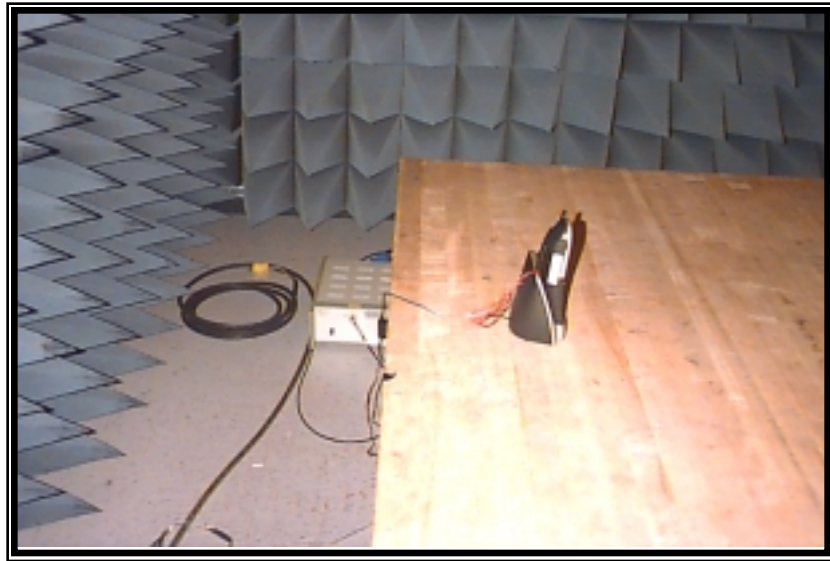

**Front View**

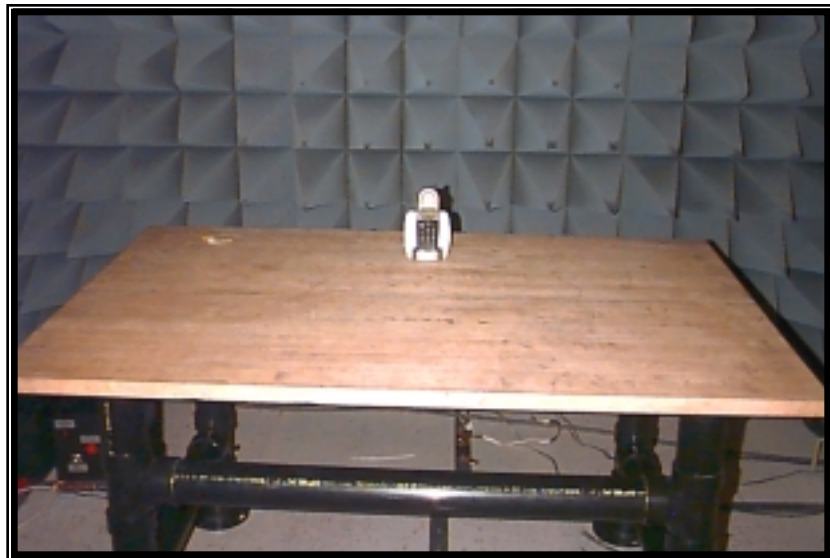

*EQUIPMENT: AT&T 2230, 2.4GHz FHSS Cordless Telephone*  
*ISSUE: 2.0*

---

**Section 4. Channel Separation**

**Para. No.: 15.247 (a)(1)**

<b>Test Performed By:</b> Glen Westwell	<b>Date of Test:</b> May 21, 2001
---	-----------------------------------

**Test Results:** Complies.

**Measurement Data:** Channel Separation: 870kHz  
Maximum 20dB Bandwidth: 707kHz

See attached graphs.





*EQUIPMENT: AT&T 2230, 2.4GHz FHSS Cordless Telephone*  
*ISSUE: 2.0*

---

## **Section 5. Pseudorandom Hopping Algorithm**

**Para. No.: 15.247 (a)(1)**

<b>Test Performed By:</b> Glen Westwell	<b>Date of Test:</b> May 22, 2001
---	-----------------------------------

**Test Results:** Complies.

**Measurement Data:** Number of Hopping Frequencies: 95

See attached Manufacturers Data

See attached graphs.

EQUIPMENT: AT&T 2230, 2.4GHz FHSS Cordless Telephone  
 ISSUE: 2.0

**3. Adaptation to 2.4GHz ISM band**

**3.1 Frame format:**

Down-link (FP to PP)      Up-link (PP to FP)

0	1	2	3	4	5	6	7
---	---	---	---	---	---	---	---

length 10 ms

**3.1.1 Crystal frequency 10.368000 MHz**

Symbol rate: 576 kbit/sec.  
 Frame length: 8 timeslots, same as 10 ms.  
 Frame frequency: 100 Hz  
 Number of symbols for frame: 5760  
 Number of symbols per slot: 720 (440 in burst and 280 in guard space)

**3.1.2 Frequency hopping**

Slots are used in pairs for duplex bearers (0,4), (1,5), etc. The FP transmit on a frequency in a slot-pair, and the PP responds on the same carrier in the up-link direction. Handset uses preamble antenna diversity to detect the best antenna for reception/transmission.

Frame	Frequency versus slot							
	0	1	2	3	4	5	6	7
N	x	y			x	y		
N+1	z	w			z	w		
N+2	v	t			v	t		

**3.2 Burst format:**

Sync field	A field	B field	XZ	Guard space
------------	---------	---------	----	-------------

**3.2.1 Sync-field**

Length: 48 symbols consisting of  
 Prolonged preamble: 16 bit data (1010b sequence)  
 Preamble for bit-synchronization: 16 bit data (1010b sequence)  
 Frame synchronization word: FP: E98Ah (1110 1001 1000 1010b sequence)  
 PP: 1675h (0001 0110 0111 0101b sequence)

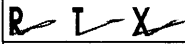
	Technical Documentation MARS 2G4 Freq. Hopping			Specification
	File marsalgorithmstypeappr oval.doc	Date 2001-05-09	Revision 0.7	Ref. JTP/FM Page 4 of 9

This document and the information contained is property of RTX Telecom A/S, Denmark. Unauthorized copying is not allowed.





EQUIPMENT: AT&T 2230, 2.4GHz FHSS Cordless Telephone  
 ISSUE: 2.0

3.3 Frequency hopping algorithm

The number of used frequencies (NUF) in the hopping algorithm is 95.  
 In FP and PP exists a PrimaryHoppingIndexNumber (PHIN). This number is incremented modulo NUF in the end of the normal downlink half-frame. It is broadcast in Q0 message instead of PSCN.

To a simplex or an established duplex bearer is assigned a HoppingIndexOffset (HIO), which is analogue to the used RF carrier in a FDMA system. This value is broadcast in place of CN in Q0 message. In the FP in all unused slots in up-link direction the receiver is scanning with HIO=0. The receiver scanning doesn't exclude RF-carriers.

Different FPs use different hopping sequences. The different sequences are derived from the hopping table by adding an offset, SequenceCode (SQC). See section 3.2.2.2.

A hopping table maps an index I to a carrier number:  $CN = f(I)$

The physical RF carrier is calculated by the formula:

$$CN = ( f((PHIN+HIO) \text{ mod } NUF) + SQC ) \text{ mod } NUF$$

3.3.1 Excluded carriers

Excluded carriers (exceptions) are fixed carriers that constantly are interfered by CW RF-carrier. The decision for excluding a RF carrier, are based on:

- RSSI monitor during scanning in the FP.
- Bearer quality in FP correlated to specific RF-carriers.
- Bearer quality detected in PP and reported using Q1 in MAC-header.

When exception carriers are included the complete algorithm is:

```

I = (PHIN+HIO) mod NUF
CN = ( f(I) + SQC ) mod NUF
While CN in ExclusionList
{
    I = (I + FreqHopIndexExcpShift) mod NUF
    CN = ( f(I) + SQC ) mod NUF
}
    
```

where  $\text{FreqHopIndexExcpShift} = (NUF-1)$ .

3.3.2 Hopping tables

Three different hopping tables are defined.

3.3.2.1 Hopping sequence for North America and most of Europe

For 10.368000 MHz crystal the frequencies are derived as:  
 Frequency:  $2401.056 \text{ MHz} + CN * 0.864000 \text{ MHz}$

	Technical Documentation <b>MARS 2G4 Freq. Hopping</b>			Specification
	File marsalgorithmstypeappr oval.doc	Date 2001-05-09	Revision 0.7	Ref. JTP/FM

This document and the information contained is property of RTX Telecom A/S, Denmark. Unauthorized copying is not allowed.

EQUIPMENT: AT&T 2230, 2.4GHz FHSS Cordless Telephone  
 ISSUE: 2.0

i	f(i)	I	f(i)	i	f(i)	i	f(i)	i	f(i)
0	0	20	2	40	27	60	13	80	40
1	23	21	18	41	12	61	33	81	1
2	62	22	81	42	89	62	65	82	28
3	8	23	11	43	25	63	50	83	55
4	43	24	36	44	87	64	79	84	35
5	16	25	72	45	14	65	56	85	53
6	71	26	54	46	57	66	91	86	24
7	47	27	69	47	41	67	42	87	44
8	19	28	21	48	74	68	80	88	82
9	61	29	3	49	32	69	48	89	51
10	76	30	37	50	70	70	15	90	90
11	29	31	10	51	9	71	85	91	38
12	59	32	34	52	58	72	5	92	83
13	22	33	66	53	78	73	88	93	30
14	52	34	7	54	45	74	17	94	46
15	86	35	68	55	20	75	84		
16	63	36	94	56	73	76	6		
17	26	37	75	57	93	77	67		
18	77	38	4	58	64	78	49		
19	31	39	60	59	39	79	92		

3.4 PP synchronization procedure

PP selects a random RF carrier and tries to receive a frame within 0.9 sec. If nothing is received then a new RF carrier is selected.

When a burst with correct A-CRC is received and it is a Nt (RFPI) the hopping sequence (SQ) is known and the PP must receive in the following frames using the hopping sequence. If the received A-field is different from a Nt, the PP selects a new RF carrier randomly and waits for Nt. In this state the PP do not have information of excluded RF carriers, but just follows the known hopping sequence without excluding any RF carriers. Only individual frames are missed on the excluded carriers. When PT3 is received, the PP is able to receive on exception carriers.

3.5 Dual slot diversity

Dual slot diversity is activated in case interference is detected. That is, two bearers are active, carrying the same B-field content. The receiver decides which of the received speech frames to use, depending on A-CRC and/or X-CRC. The setup and release of the 2nd bearer are performed dynamically by the FP-MAC and PP-MAC to adapt to current interference level. The two bearers are managed independently in the MAC, like a stalled intra-cell bearer hand-over with two established bearers. HoppingIndexOffset (HIO) for the two bearers are selected independently.

 File marsalgorithmstypeappr oval.doc	Technical Documentation <b>MARS 2G4 Freq. Hopping</b>			Specification
	Date 2001-05-09	Revision 0.7	Ref. JTP/FM	Page 7 of 9

This document and the information contained is property of RTX Telecom A/S, Denmark. Unauthorized copying is not allowed.

EQUIPMENT: AT&T 2230, 2.4GHz FHSS Cordless Telephone  
 ISSUE: 2.0

**3.6 Power amplifier activation**

**3.6.1 External connection**

The FP has one connection active at all times to make synchronization of the PP possible. In case a speech connection is active one slot will be active in down-link direction and one slot will be active from in up-link direction. The power amplifier will be active from start of sync field to the end of XZ field, which is slightly less than 1/12 of the total frame. In case dual slot diversity is active, two slots will be active equal to 2/12 of a frame.

**3.6.2 Internal connection**

Two handsets are able to make an internal connection. In this case two bearers will be active in the down-link direction from FP, and one bearer will be active from each handset. The two bearers in down-link direction are not correlated and uses different HoppingIndeOffset. Dual slot diversity is activated independently towards each handset, i.e. up to four bearers may be activated in down-link direction, and two bearer may be active in up-link direction.

		Technical Documentation <b>MARS 2G4 Freq. Hopping</b>		Specification
		File marsalgorithmstypeappr oval.doc	Date 2001-05-09	Revision 0.7

This document and the information contained is property of RTX Telecom A/S, Denmark. Unauthorized copying is not allowed.

EQUIPMENT: AT&T 2230, 2.4GHz FHSS Cordless Telephone  
ISSUE: 2.0

---

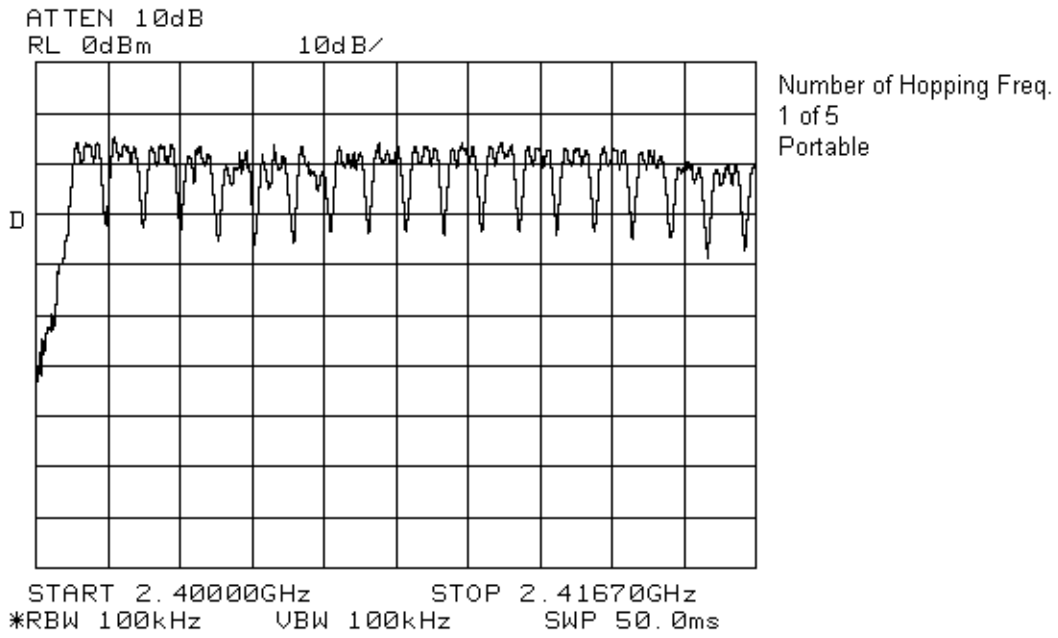

EQUIPMENT: AT&T 2230, 2.4GHz FHSS Cordless Telephone  
ISSUE: 2.0

---

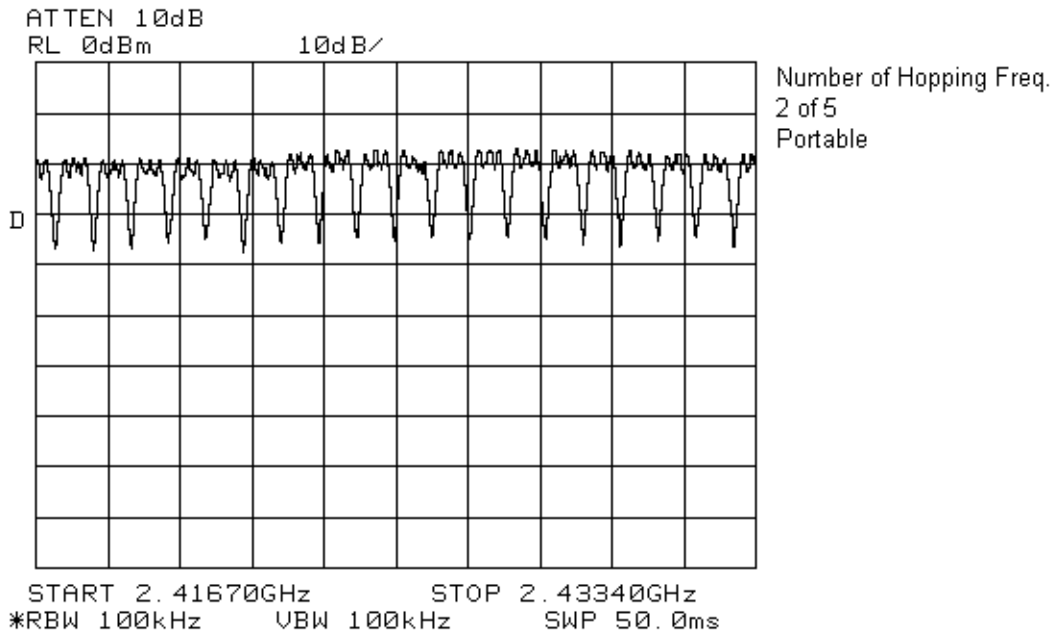

EQUIPMENT: AT&T 2230, 2.4GHz FHSS Cordless Telephone  
ISSUE: 2.0

---

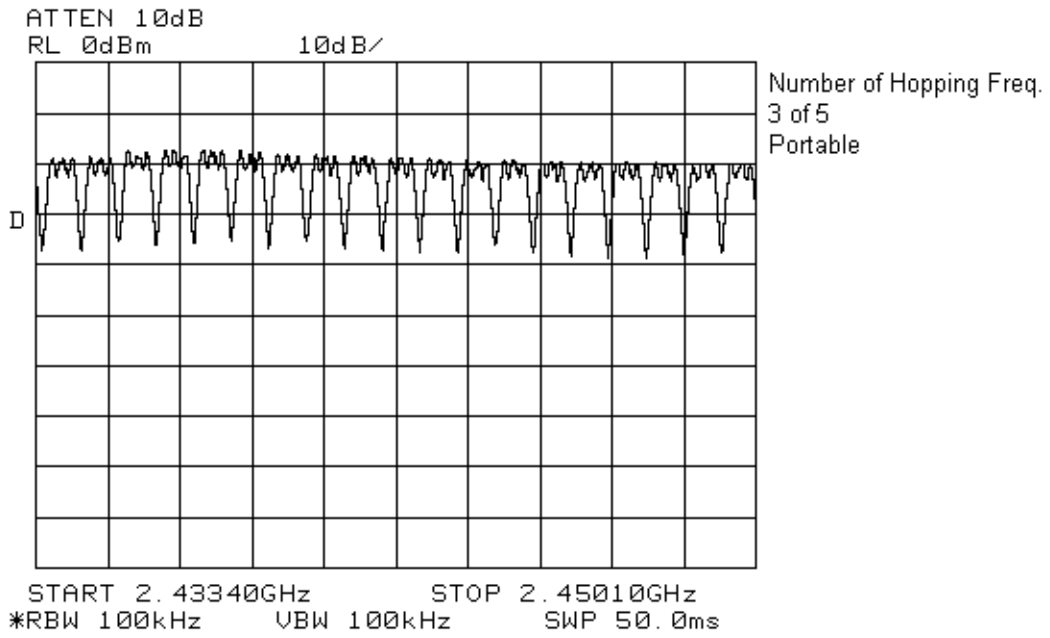

EQUIPMENT: AT&T 2230, 2.4GHz FHSS Cordless Telephone  
ISSUE: 2.0

---

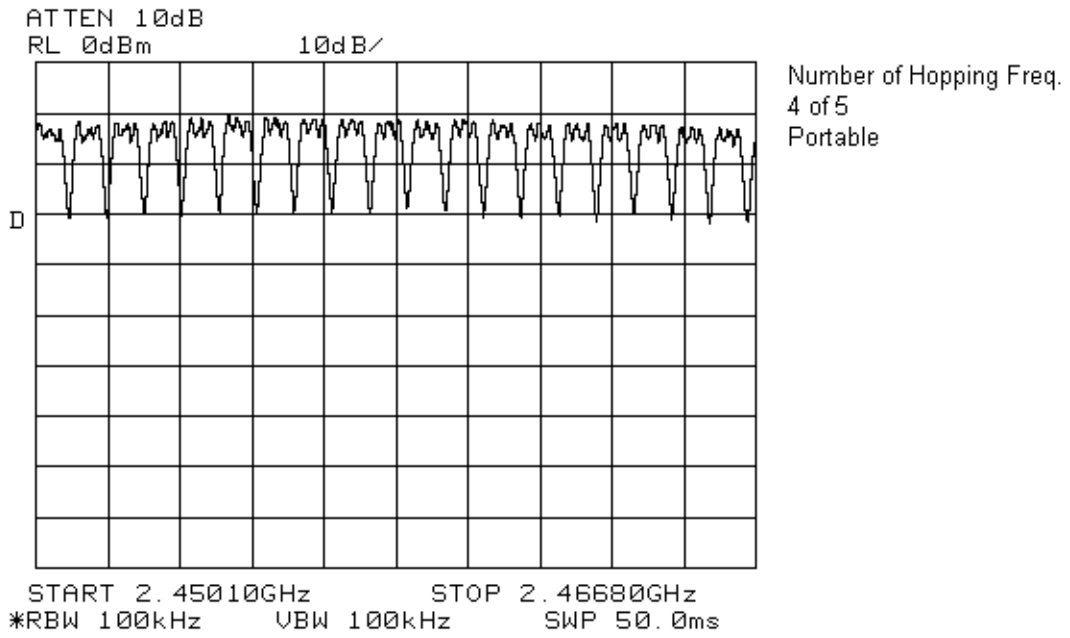



EQUIPMENT: AT&T 2230, 2.4GHz FHSS Cordless Telephone  
ISSUE: 2.0

---

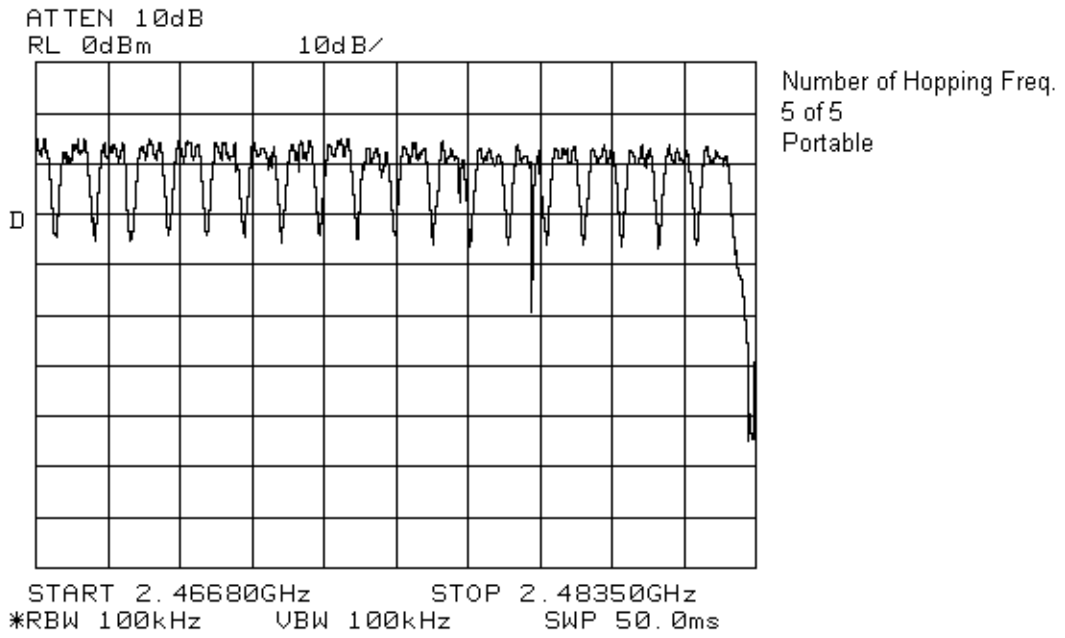



EQUIPMENT: AT&T 2230, 2.4GHz FHSS Cordless Telephone  
ISSUE: 2.0

---

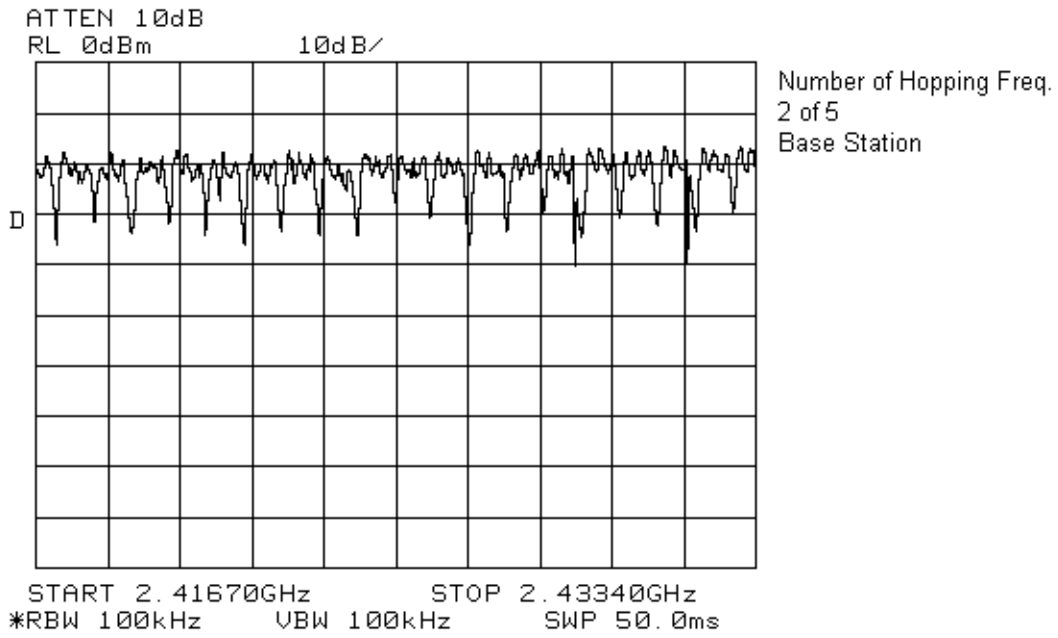

EQUIPMENT: AT&T 2230, 2.4GHz FHSS Cordless Telephone  
ISSUE: 2.0

---

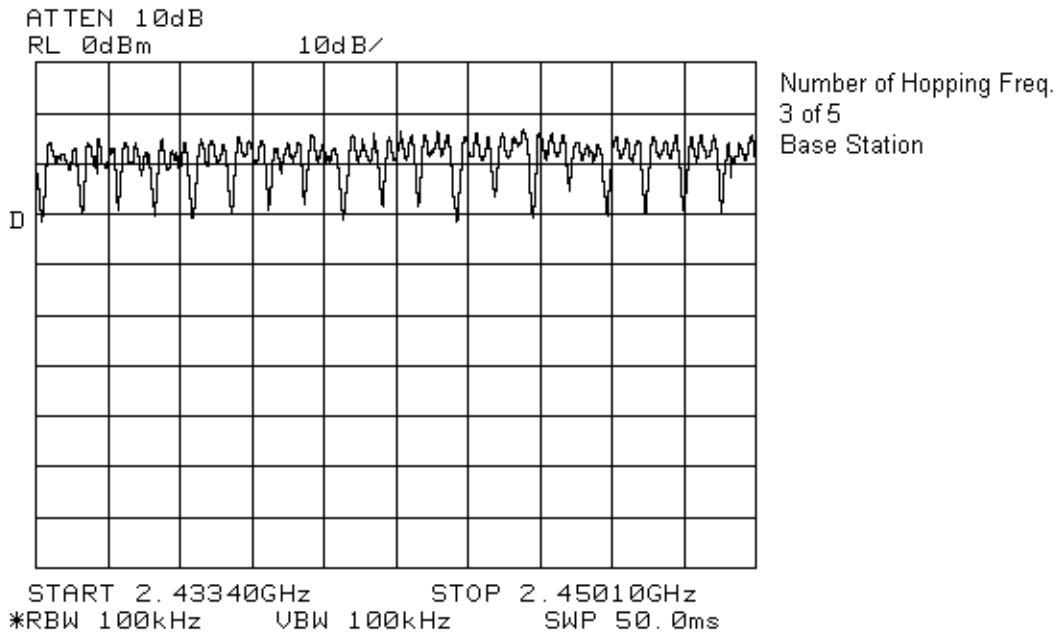

EQUIPMENT: AT&T 2230, 2.4GHz FHSS Cordless Telephone  
ISSUE: 2.0

---

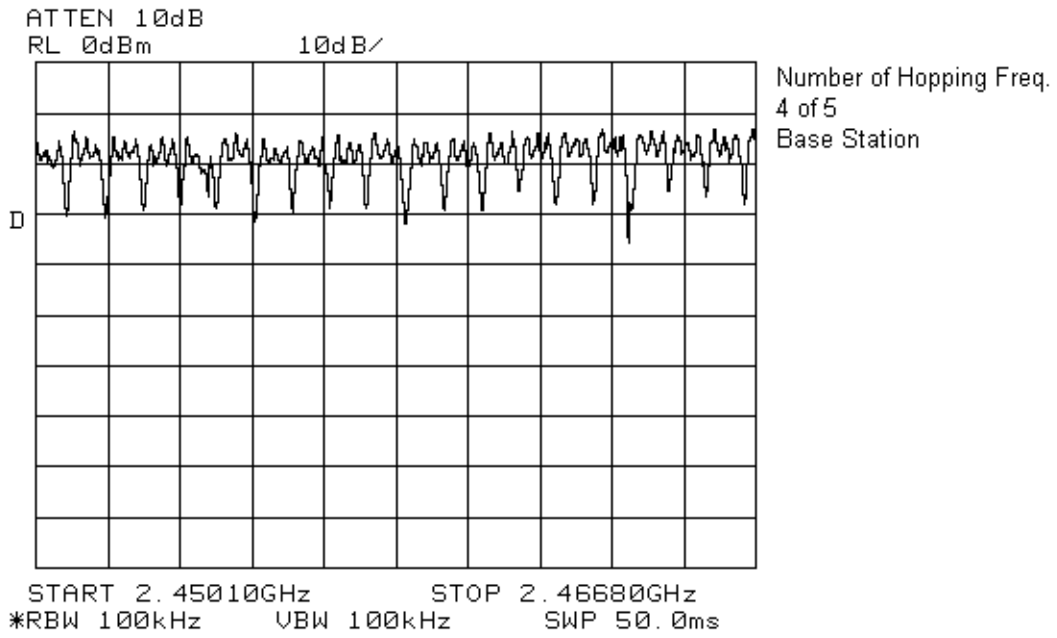

EQUIPMENT: AT&T 2230, 2.4GHz FHSS Cordless Telephone  
ISSUE: 2.0

---

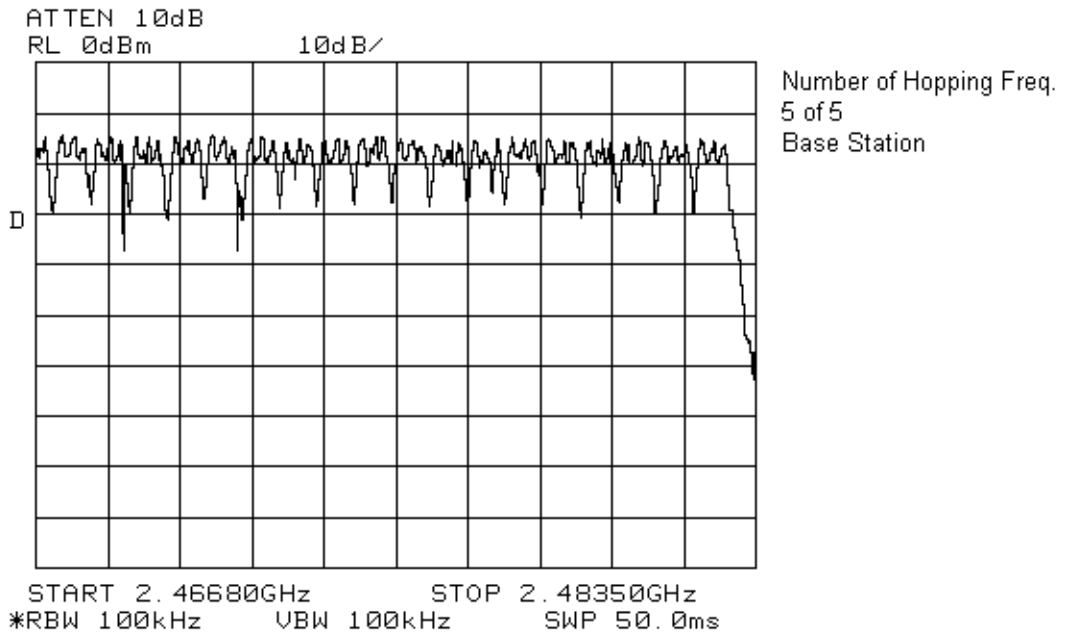

*EQUIPMENT: AT&T 2230, 2.4GHz FHSS Cordless Telephone*  
*ISSUE: 2.0*

---

**Section 6. Time of Occupancy**

**Para. No.: 15.247 (a)(1)(ii)**

<b>Test Performed By:</b> Glen Westwell	<b>Date of Test:</b> May 22, 2001
---	-----------------------------------

**Test Results:** Complies.

**Measurement Data:** Maximum Dwell Time On Any Channel:  
32 Time Occupied on Channel 47 in a 30 second period.

Base Station: 32 x 835.2 $\mu$ Sec = 26.73mSec  
Portable: 32 x 840 $\mu$ Sec = 26.88mSec

See attached graphs.





EQUIPMENT: AT&T 2230, 2.4GHz FHSS Cordless Telephone  
ISSUE: 2.0

---

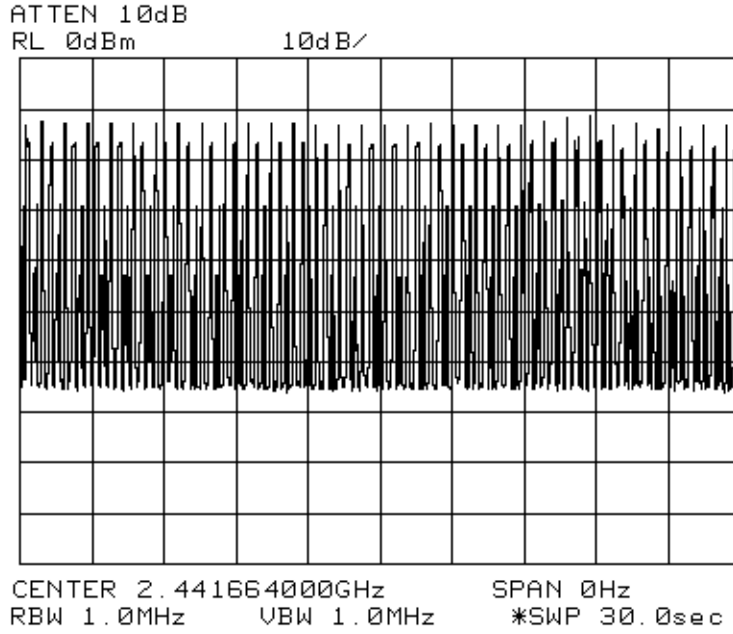

Portable  
Time of Occupancy  
Hopping "On"  
32 Peaks in a 30Sec Period.

EQUIPMENT: AT&T 2230, 2.4GHz FHSS Cordless Telephone  
ISSUE: 2.0

---

Base Station

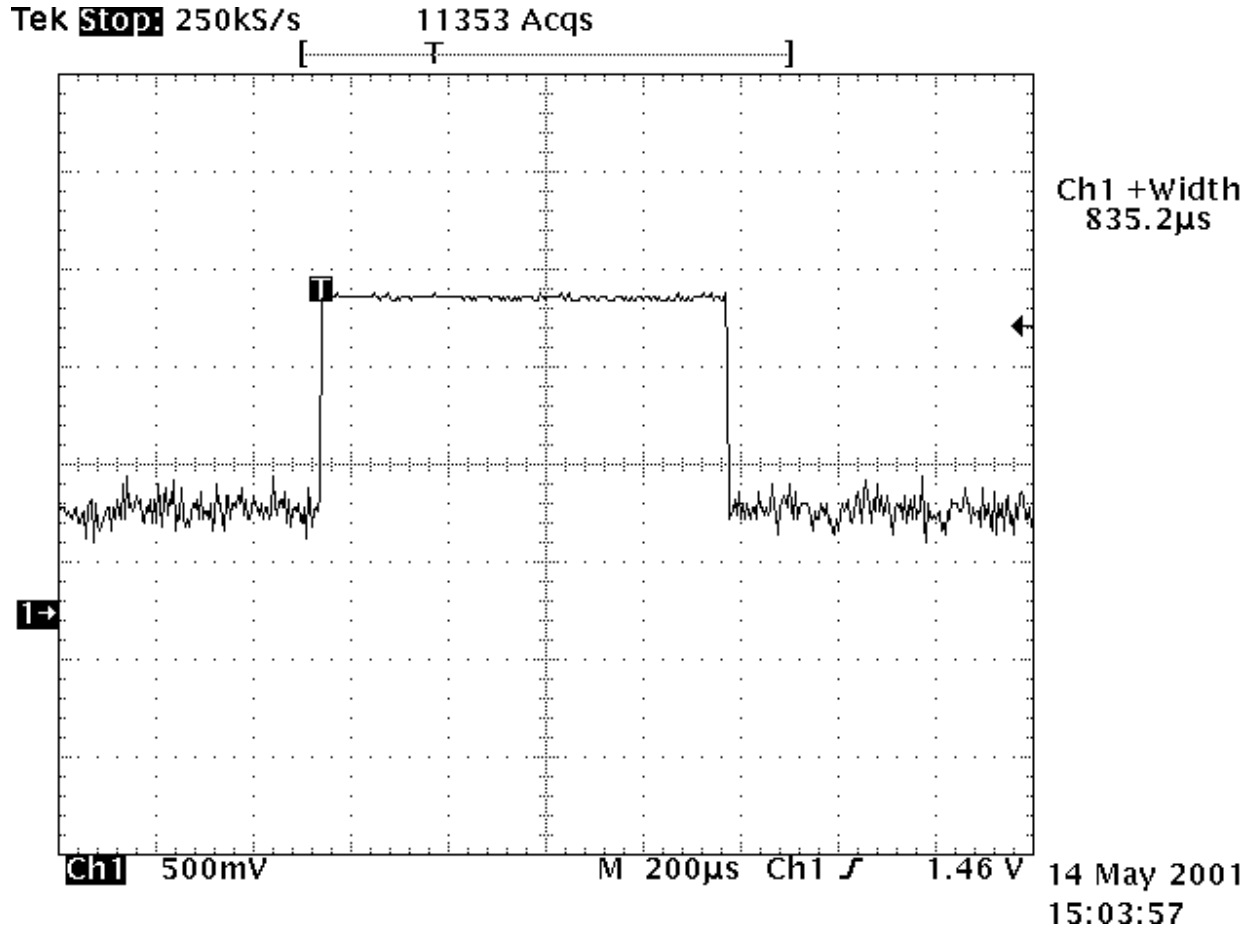

EQUIPMENT: AT&T 2230, 2.4GHz FHSS Cordless Telephone  
ISSUE: 2.0

---

Portable

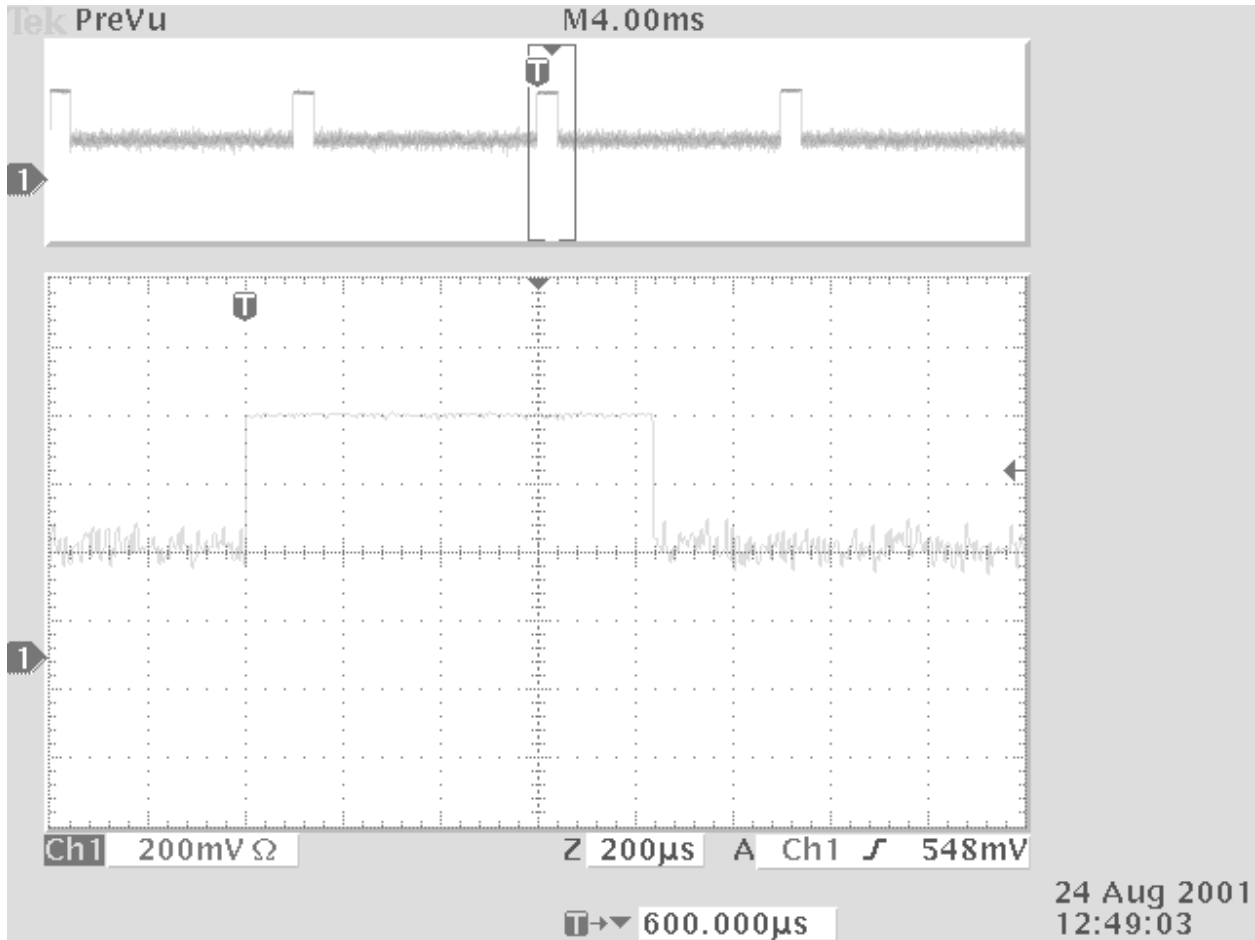

*EQUIPMENT: AT&T 2230, 2.4GHz FHSS Cordless Telephone*  
*ISSUE: 2.0*

---

**Section 7. Occupied Bandwidth**

**Para. No.: 15.247 (a)(1)(ii)**

<b>Test Performed By:</b> Glen Westwell	<b>Date of Test:</b> May 23, 2001
---	-----------------------------------

**Test Results:** Complies.

**Measurement Data:** Maximum Occupied Bandwidth = 707kHz

See attached graphs.







*EQUIPMENT: AT&T 2230, 2.4GHz FHSS Cordless Telephone*  
*ISSUE: 2.0*

---

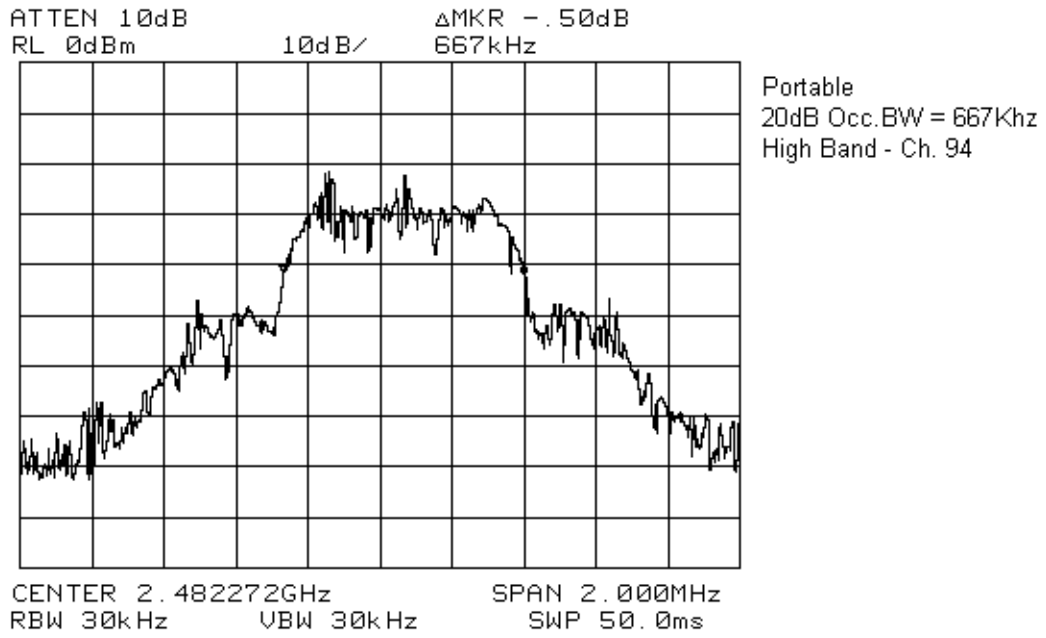







*EQUIPMENT: AT&T 2230, 2.4GHz FHSS Cordless Telephone*  
*ISSUE: 2.0*

---

**Section 8. Peak Power Output**

**Para. No.: 15.247 (b)**

<b>Test Performed By:</b> Glen Westwell & Russell Grant	<b>Date of Test:</b> August 22, 2001
---	--------------------------------------

**Test Results:** Complies. The maximum peak power output of the transmitter is 0.155W.

**Measurement Data:** Detachable antenna?  Yes  No

If yes, state the type of non-standard connector used at the antenna port:

Directional Gain of Antenna: 0 dBi or 1 Numeric.

Maximum Peak Power Output = 21.9dBm, 0.155W

This was measured using the signal substitution method. The EUT was replaced with signal generator and standard gain horn antenna. The measured RF power into the horn antenna and gain of the antenna were used to determine maximum EIRP.

Manufacturers Rating of RF Power Output:

Handset: 23dBm  
Base Set: 24dBm















EQUIPMENT: AT&T 2230, 2.4GHz FHSS Cordless Telephone  
ISSUE: 2.0

---

## Section 9. Spurious Emissions (Radiated)

Para. No.: 15.247 (c)

Test Performed By: Glen Westwell	Date of Test: May 24, 2001
----------------------------------	----------------------------

**Test Results:** Complies. The worst case emission level is 50.0dB $\mu$ V/m @ 3m at 4883MHz. This is 4.0 dB below the specification limit.

**Measurement Data:** See attached table.

**Duty Cycle Calculation:** Base Station:  $15 \times 835.2\mu\text{Sec} = 12.53\text{mSec}$   
 $20\text{Log} \frac{12.53\text{ms}}{100\text{ms}} = -18\text{dB}$

Portable:  $10 \times 165.6\mu\text{Sec} = 1.66\text{mSec}$   
 $20\text{Log} \frac{1.66\text{ms}}{100\text{ms}} = -35.6\text{dB}, \therefore -20\text{dB}$

- Handheld portable and base station equipment is tested on three orthogonal axis.
- The worst case emission levels are reported.

*EQUIPMENT: AT&T 2230, 2.4GHz FHSS Cordless Telephone*  
*ISSUE: 2.0*

---

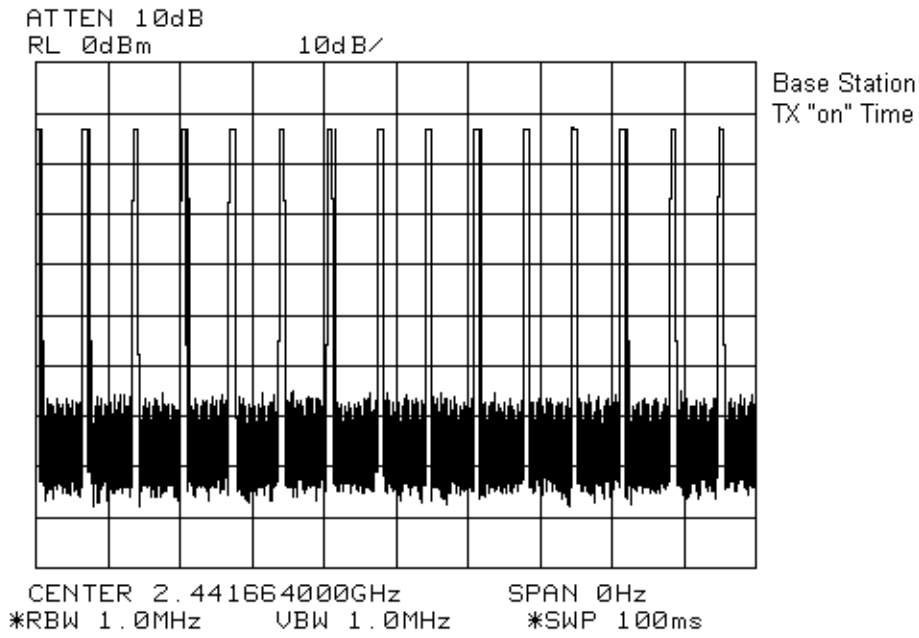

EQUIPMENT: AT&T 2230, 2.4GHz FHSS Cordless Telephone  
ISSUE: 2.0

---

Base Station

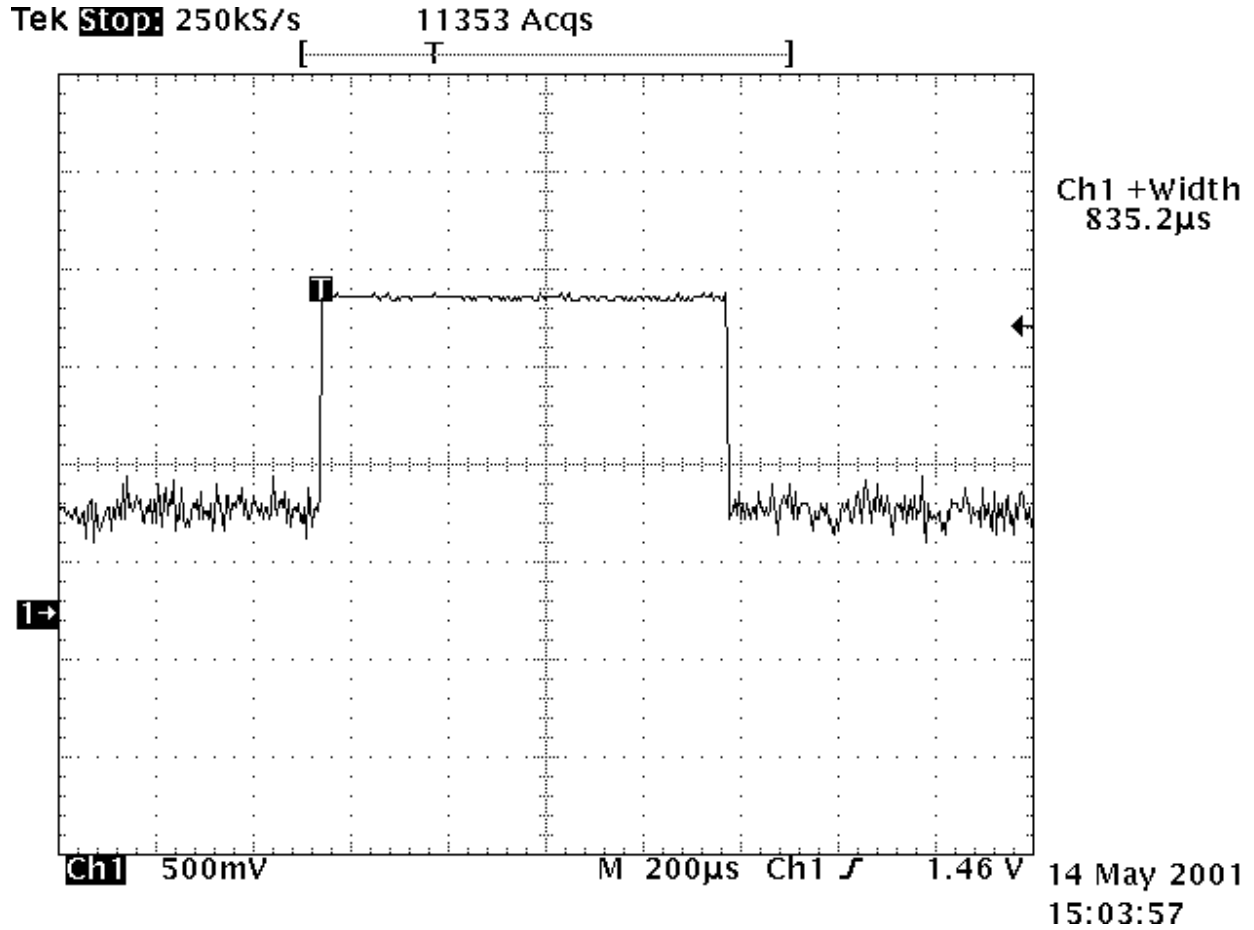

EQUIPMENT: AT&T 2230, 2.4GHz FHSS Cordless Telephone  
ISSUE: 2.0

---

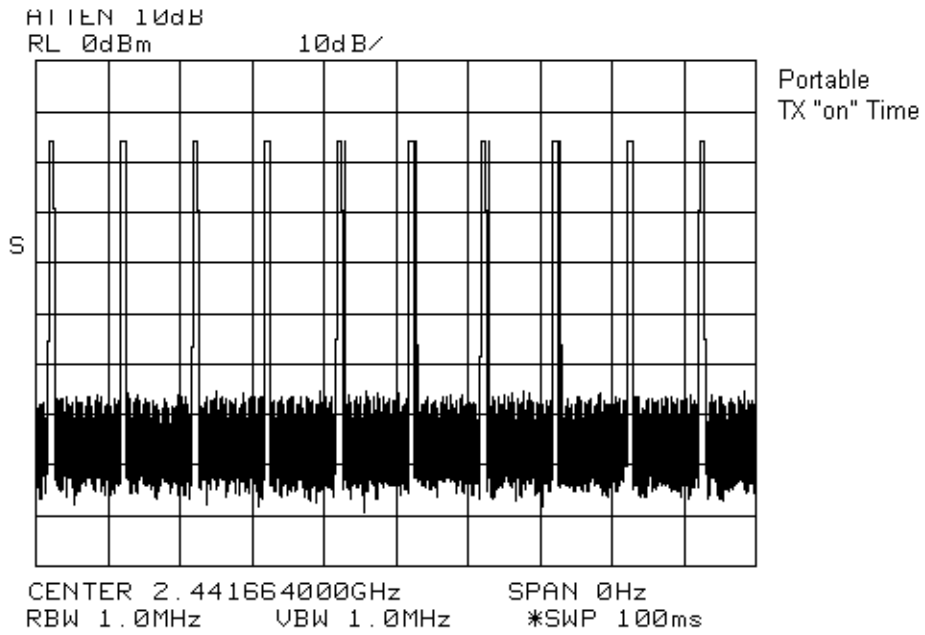

EQUIPMENT: AT&T 2230, 2.4GHz FHSS Cordless Telephone  
ISSUE: 2.0

---

Portable

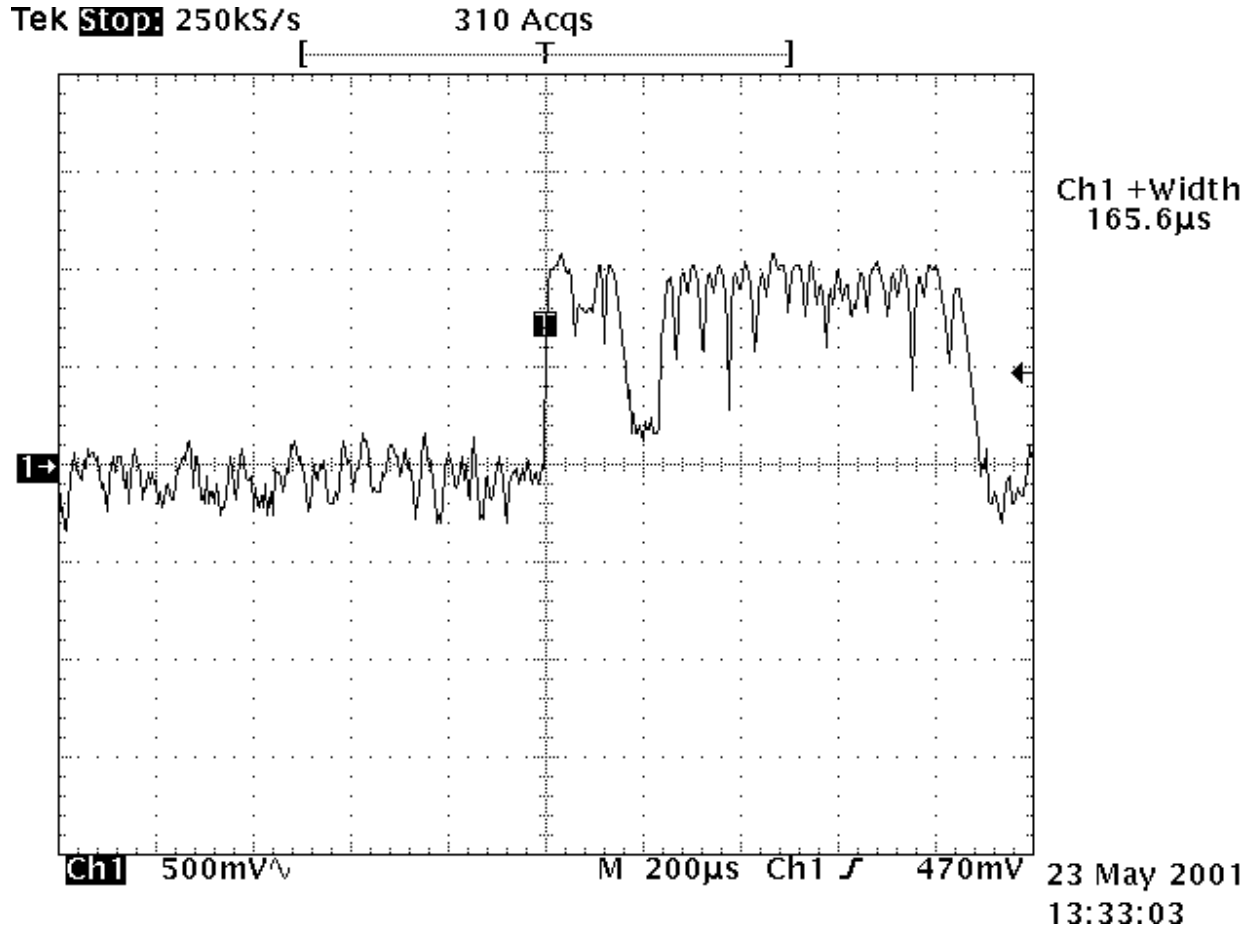













EQUIPMENT: AT&T 2230, 2.4GHz FHSS Cordless Telephone  
ISSUE: 2.0

---

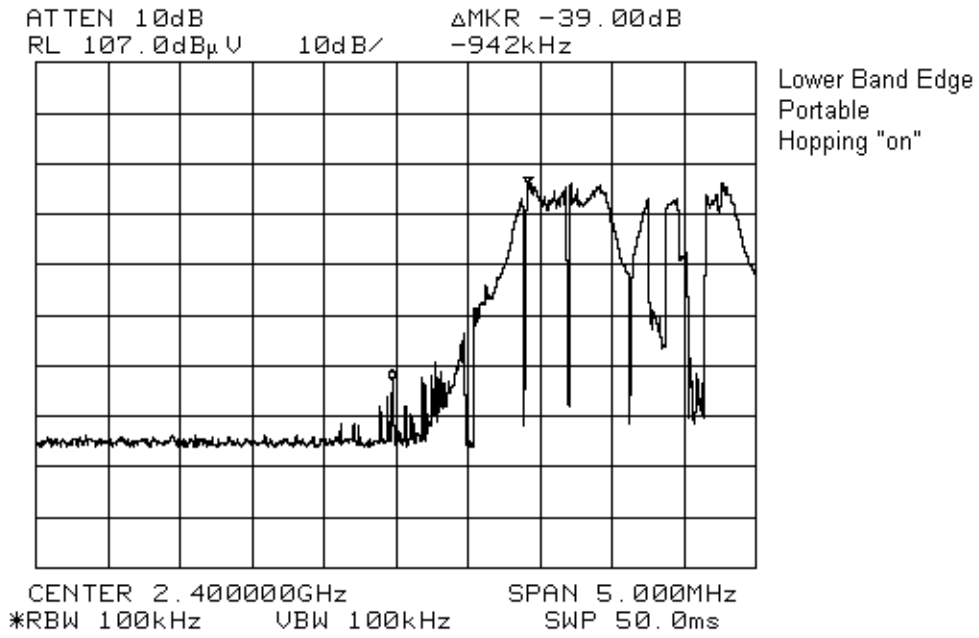





EQUIPMENT: AT&T 2230, 2.4GHz FHSS Cordless Telephone  
 ISSUE: 2.0

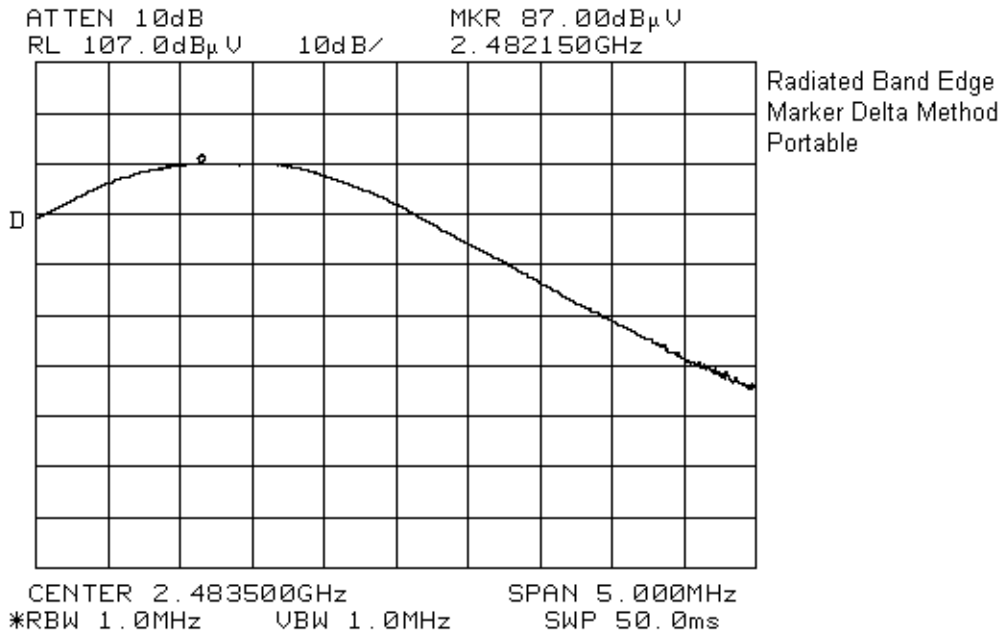

Band Edge Level: = 87.0 - 8 = 79.0dBµV  
 Antenna Factor: = 36dB  
 Band Edge Peak: = 115dBµV

Band Edge Level: 115dBµV  
 Marker Delta: -46.8dB  
 Duty Cycle Correction: -20.0dB

---

48.2dBµV @ 3 meters





EQUIPMENT: AT&T 2230, 2.4GHz FHSS Cordless Telephone  
 ISSUE: 2.0

**Test Data - Radiated Emissions (Peak) Portable**

Test Distance (meters) : 3		Range: A Tower		Receiver: HP 8465E		RBW: 1 MHz		Detector: Peak	
Freq. (MHz)	Ant. *	Pol. (V/H)	RCVD Signal (dBµV/m)	Ant. Factor (dB)**	Amp. Gain (dB)***	Dist. Corr. (dB)	Field Strength (dBµV/m)	Limit (dBµV/m)	Margin (dB)
<b>Channel 1</b>									
4802.11		H	77.2	43.6	-55.6		65.2	74.0	8.8
4802.11		V	77.1	43.6	-55.6		65.1	74.0	8.9
7203.17		H	64.3	50.7	-55.8		59.2	74.0	14.8
7203.17		V	66.2	50.7	-55.8		61.1	74.0	12.9
<b>Channel 47</b>									
4883.33		H	74.3	43.9	-55.4		62.8	74.0	11.2
4883.33		V	73.3	43.9	-55.4		61.8	74.0	12.2
7324.99		H	65.7	50.9	-55.7		60.9	74.0	13.1
7324.99		V	65.4	50.9	-55.7		60.6	74.0	13.4
<b>Channel 94</b>									
4964.54		H	71.5	44.2	-55.1		60.6	74.0	13.4
4964.54		V	22.0	44.2	-55.1		61.1	74.0	12.9
7446.82		H	64.2	51.3	-55.7		59.8	74.0	14.2
7446.82		V	64.9	51.3	-55.7		60.5	74.0	13.5
<b>Notes:</b>									
B/C = Biconical, B/L = Biconilog, L/P = Log-Periodic, H = Horn, D/P = Dipole									
* Re-measured using dipole antenna.									
** Includes cable loss when amplifier is not used.									
*** Includes cable loss.									
( ) Denotes failing emission level.									
N.D. = Not Detected									

EQUIPMENT: AT&T 2230, 2.4GHz FHSS Cordless Telephone  
 ISSUE: 2.0

**Test Data - Radiated Emissions (Average) Portable**

Test Distance (meters) : 3		Range: A Tower		Receiver: HP 8465E		RBW: 1 MHz		Detector: Peak	
Freq. (MHz)	Ant. *	Pol. (V/H)	RCVD Signal (dBµV/m)	Ant. Factor (dB)**	Amp. Gain (dB)***	Duty Cycle Corr. (dB)	Field Strength (dBµV/m)	Limit (dBµV/m)	Margin (dB)
<b>Channel 1</b>									
4802.11		H	77.2	43.6	-55.6	-20	45.2	54.0	8.8
4802.11		V	77.1	43.6	-55.6	-20	45.1	54.0	8.914.8
7203.17		H	64.3	50.7	-55.8	-20	39.2	54.0	18.9
7203.17		V	66.2	50.7	-55.8	-20	41.1	54.0	
<b>Channel 47</b>									
4883.33		H	74.3	43.9	-55.4	-20	42.8	54.0	11.2
4883.33		V	73.3	43.9	-55.4	-20	41.8	54.0	12.2
7324.99		H	65.7	50.9	-55.7	-20	40.9	54.0	13.1
7324.99		V	65.4	50.9	-55.7	-20	40.6	54.0	13.4
<b>Channel 94</b>									
4964.54		H	71.5	44.2	-55.1	-20	40.6	54.0	13.4
4964.54		V	22.0	44.2	-55.1	-20	41.1	54.0	12.9
7446.82		H	64.2	51.3	-55.7	-20	39.8	54.0	14.2
7446.82		V	64.9	51.3	-55.7	-20	40.5	54.0	13.5
<b>Notes:</b>									
B/C = Biconical, B/L = Biconilog, L/P = Log-Periodic, H = Horn, D/P = Dipole									
* Re-measured using dipole antenna.									
** Includes cable loss when amplifier is not used.									
*** Includes cable loss.									
( ) Denotes failing emission level.									
N.D. = Not Detected									

EQUIPMENT: AT&T 2230, 2.4GHz FHSS Cordless Telephone  
 ISSUE: 2.0

**Test Data - Radiated Emissions (Peak) Base Station**

Test Distance (meters) : 3		Range: A Tower		Receiver: HP 8465E		RBW: 1 MHz		Detector: Peak	
Freq. (MHz)	Ant. *	Pol. (V/H)	RCVD Signal (dBµV/m)	Ant. Factor (dB)**	Amp. Gain (dB)***	Dist. Corr. (dB)	Field Strength (dBµV/m)	Limit (dBµV/m)	Margin (dB)
<b>Channel 1</b>									
4802.11		V	72.5	43.6	-55.6		60.5	74.0	13.5
4802.11		H	76.7	43.6	-55.6		64.7	74.0	9.3
7203.17		V	67.2	50.7	-55.8		62.1	74.0	11.9
7203.17		H	72.8	50.7	-55.8		67.7	74.0	6.3
<b>Channel 4</b>									
4883.33		H	79.5	43.9	-55.4		68.0	74.0	6.0
4883.33		V	73.8	43.9	-55.4		62.3	74.0	11.7
7324.99		H	71.0	50.9	-55.7		66.2	74.0	7.8
7324.99		V	72.3	50.9	-55.7		67.5	74.0	6.5
<b>Channel 94</b>									
4964.54		V	77.0	44.2	-55.1		66.1	74.0	7.9
4964.54		H	78.0	44.2	-55.1		67.1	74.0	6.9
7446.82		V	66.7	51.3	-55.7		62.3	74.0	11.7
7446.82		H	67.0	51.3	-55.7		62.6	74.0	11.4
<b>Notes:</b>									
B/C = Biconical, B/L = Biconilog, L/P = Log-Periodic, H = Horn, D/P = Dipole									
* Re-measured using dipole antenna.									
** Includes cable loss when amplifier is not used.									
*** Includes cable loss.									
( ) Denotes failing emission level.									
N.D. = Not Detected									

EQUIPMENT: AT&T 2230, 2.4GHz FHSS Cordless Telephone  
 ISSUE: 2.0

**Test Data - Radiated Emissions (Average) Base Station**

Test Distance (meters) : 3		Range: A Tower		Receiver: HP 8465E		RBW: 1 MHz		Detector: Peak	
Freq. (MHz)	Ant. *	Pol. (V/H)	RCVD Signal (dBµV/m)	Ant. Factor (dB)**	Amp. Gain (dB)***	Dist. Corr. (dB)	Field Strength (dBµV/m)	Limit (dBµV/m)	Margin (dB)
<b>Channel 1</b>									
4802.11		V	72.5	43.6	-55.6	-18.0	42.5	54.0	11.5
4802.11		H	76.7	43.6	-55.6	-18.0	46.7	54.0	7.3
7203.17		V	67.2	50.7	-55.8	-18.0	44.1	54.0	9.9
7203.17		H	72.8	50.7	-55.8	-18.0	49.7	54.0	4.3
<b>Channel 4</b>									
4883.33		H	79.5	43.9	-55.4	-18.0	50.0	54.0	4.0
4883.33		V	73.8	43.9	-55.4	-18.0	44.3	54.0	9.7
7324.99		H	71.0	50.9	-55.7	-18.0	48.2	54.0	5.8
7324.99		V	72.3	50.9	-55.7	-18.0	49.5	54.0	4.5
<b>Channel 94</b>									
4964.54		V	77.0	44.2	-55.1	-18.0	48.1	54.0	5.9
4964.54		H	78.0	44.2	-55.1	-18.0	49.1	54.0	4.9
7446.82		V	66.7	51.3	-55.7	-18.0	44.3	54.0	9.7
7446.82		H	67.0	51.3	-55.7	-18.0	44.6	54.0	9.4
<b>Notes:</b>									
B/C = Biconical, B/L = Biconilog, L/P = Log-Periodic, H = Horn, D/P = Dipole									
* Re-measured using dipole antenna.									
** Includes cable loss when amplifier is not used.									
*** Includes cable loss.									
( ) Denotes failing emission level.									
N.D. = Not Detected									

*EQUIPMENT: AT&T 2230, 2.4GHz FHSS Cordless Telephone*  
*ISSUE: 2.0*

---

**Radiated Photographs (Worst Case Configuration)**

**Front View**



**Rear View**

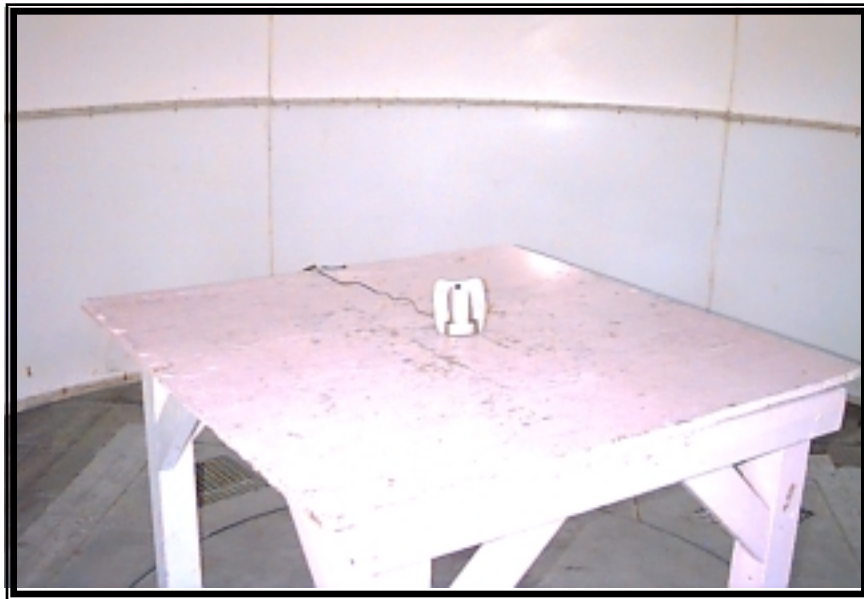

*EQUIPMENT: AT&T 2230, 2.4GHz FHSS Cordless Telephone*  
*ISSUE: 2.0*

---

**Section 10. Test Equipment List**

<b>CAL CYCLE</b>	<b>EQUIPMENT</b>	<b>MANUFACTURER</b>	<b>MODEL</b>	<b>SERIAL</b>	<b>LAST CAL.</b>	<b>NEXT CAL.</b>
1 Year	Spectrum Analyzer	Hewlett Packard	8565E	FA000981	June 16/00	June 16/01
1 Year	Spectrum Analyzer-1	Hewlett Packard	8566B	2311A02238	Dec. 10/00	Dec. 10/01
1 Year	Spectrum Analyzer Display-1	Hewlett Packard	8566B	2314A04759	Dec. 10/00	Dec. 10/01
1 Year	Quasi-peak adapter-1	Hewlett-Packard	85650A	2043A00302	Dec. 14/00	Dec. 14/01
1 Year	LISN	EMCO	4825/2	0002-1/47	Feb. 14/00	Aug. 14/01
1 Year	Horn Antenna	EMCO #2	3115	4336	Dec. 1/00	Dec. 1/01
1 Year	Plotter	Hewlett Packard	7550A	FA001129	NCR	NCR
	High Pass Filter	K&L	11SH10-4000	FA001340	COU	COU
1 Year	RF AMP	JCA	48-600	FA001497	Aug. 31/00	Aug. 31/01

NA: Not Applicable  
 NCR: No Cal Required  
 COU: CAL On Use

*EQUIPMENT: AT&T 2230, 2.4GHz FHSS Cordless Telephone*  
*ISSUE: 2.0*

---

**Annex A**  
**Block Diagrams**

EQUIPMENT: AT&T 2230, 2.4GHz FHSS Cordless Telephone  
ISSUE: 2.0

---

### Test Site For Radiated Emissions

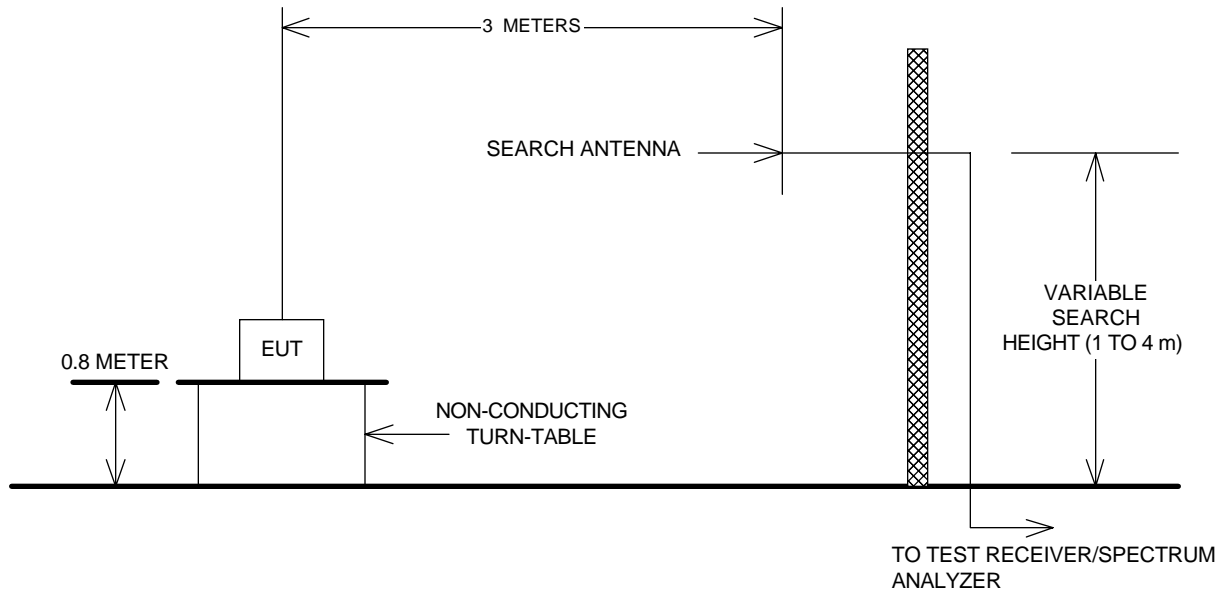

### Conducted Emissions

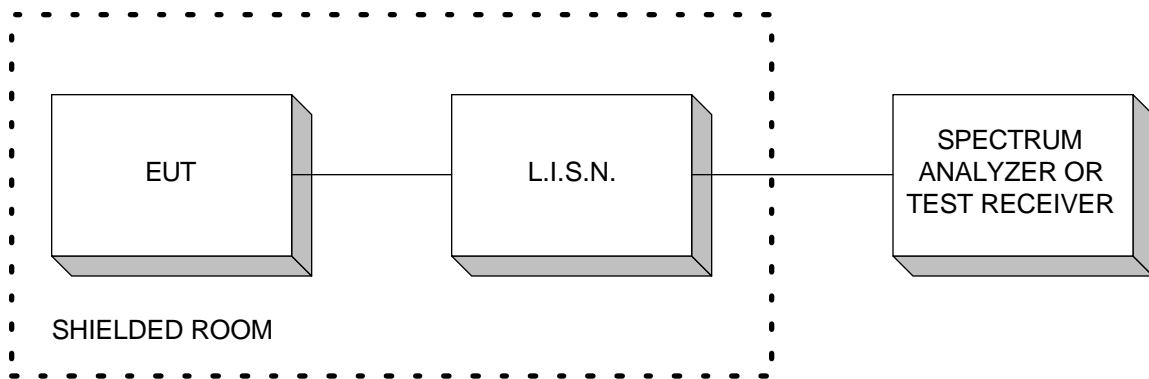



*EQUIPMENT: AT&T 2230, 2.4GHz FHSS Cordless Telephone*  
*ISSUE: 2.0*

---

**Peak Power At Antenna Terminals**

