

APPENDIX 4: Photographs of test setup

1. Information of host device

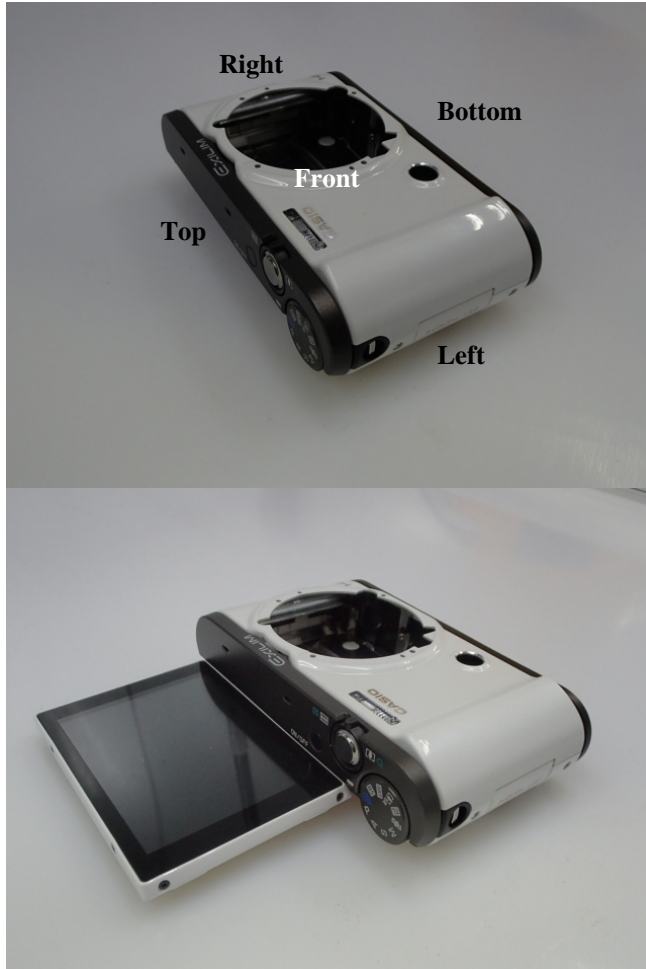

For Rear position, test was performed with LCD panel opened because it was nearer to antenna than that of LCD panel was closed.

Type of Equipment	Digital Camera
Model Number *1)	EX-ZR3500(Tested Model) EX-ZR3000, EX-ZR2000, EX-ZR1600 (Variant Model)
Serial Number	No.2
Rating	Rechargeable lithium ion battery: NP-130A, Rated Voltage 3.7 V, Rated Capacitance 1800 mAh
Category Identified	Portable device

*1) The model: EX-ZR3500 has been chosen as a representative model for testing among 4 models (EX-ZR3500, EX-ZR3000, EX-ZR2000, EX-ZR1600).

The difference between EX-ZR3500 and EX-ZR3000 are sales area and model name only.

The difference between EX-ZR2000 and EX-ZR1600 are sales area and model name only.

In addition, the difference between Model No. EX-ZR3500 (EX-ZR3000) and EX-ZR2000 (EX-ZR1600) is only thickness of the lens.

The test was performed on the Digital camera without a protrusion (lens) in order to make more conservative test configuration.

2. Antenna position

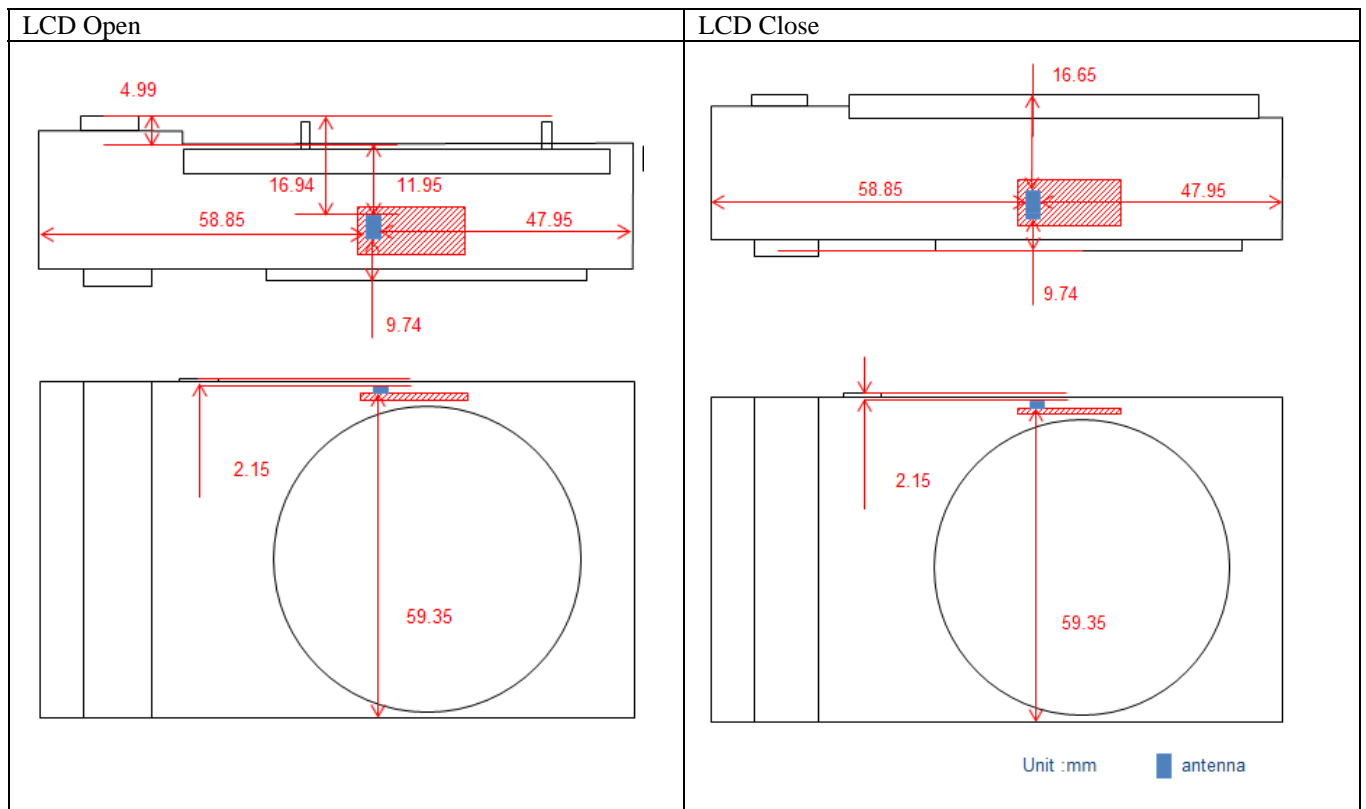

3. Photographs of setup

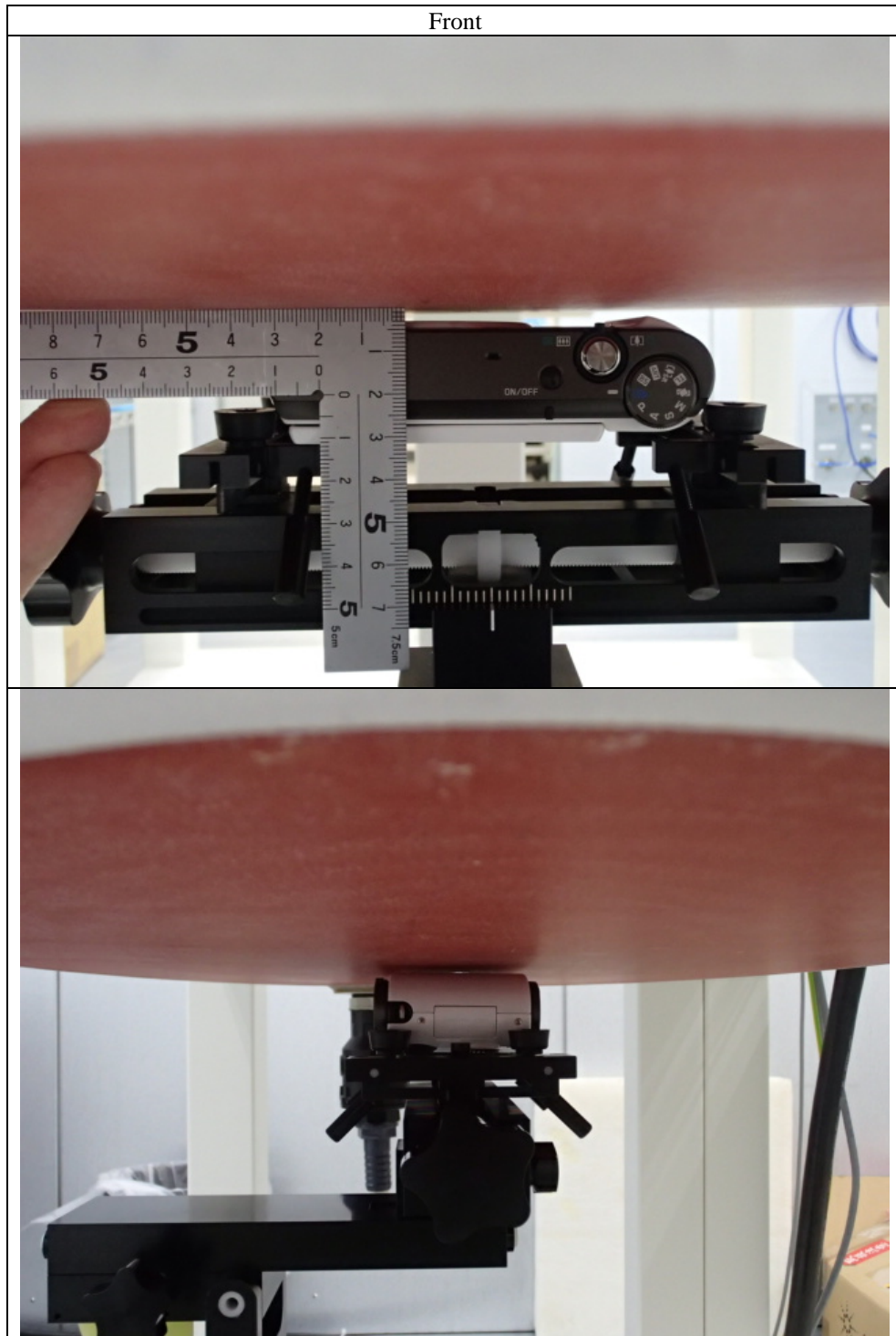

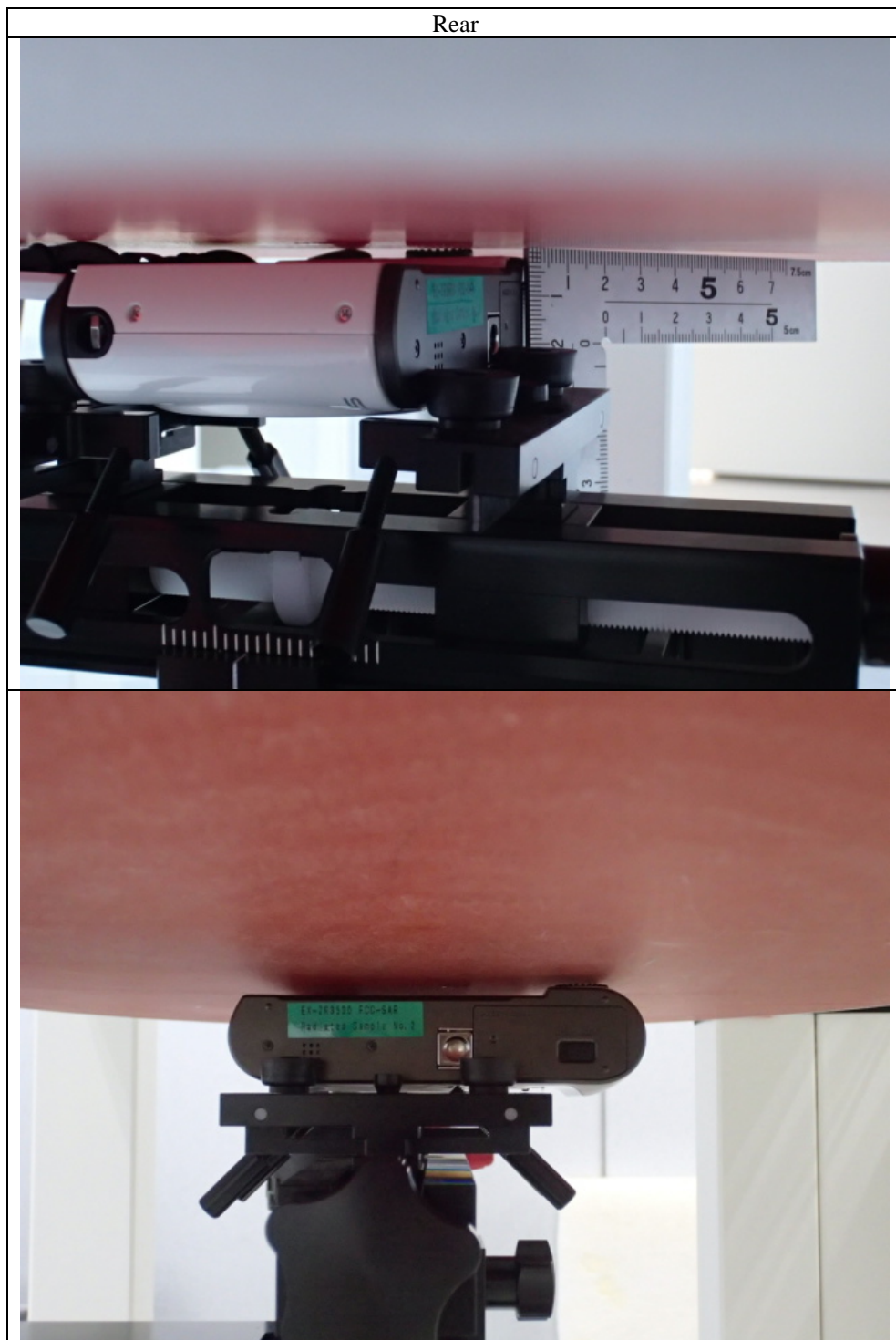

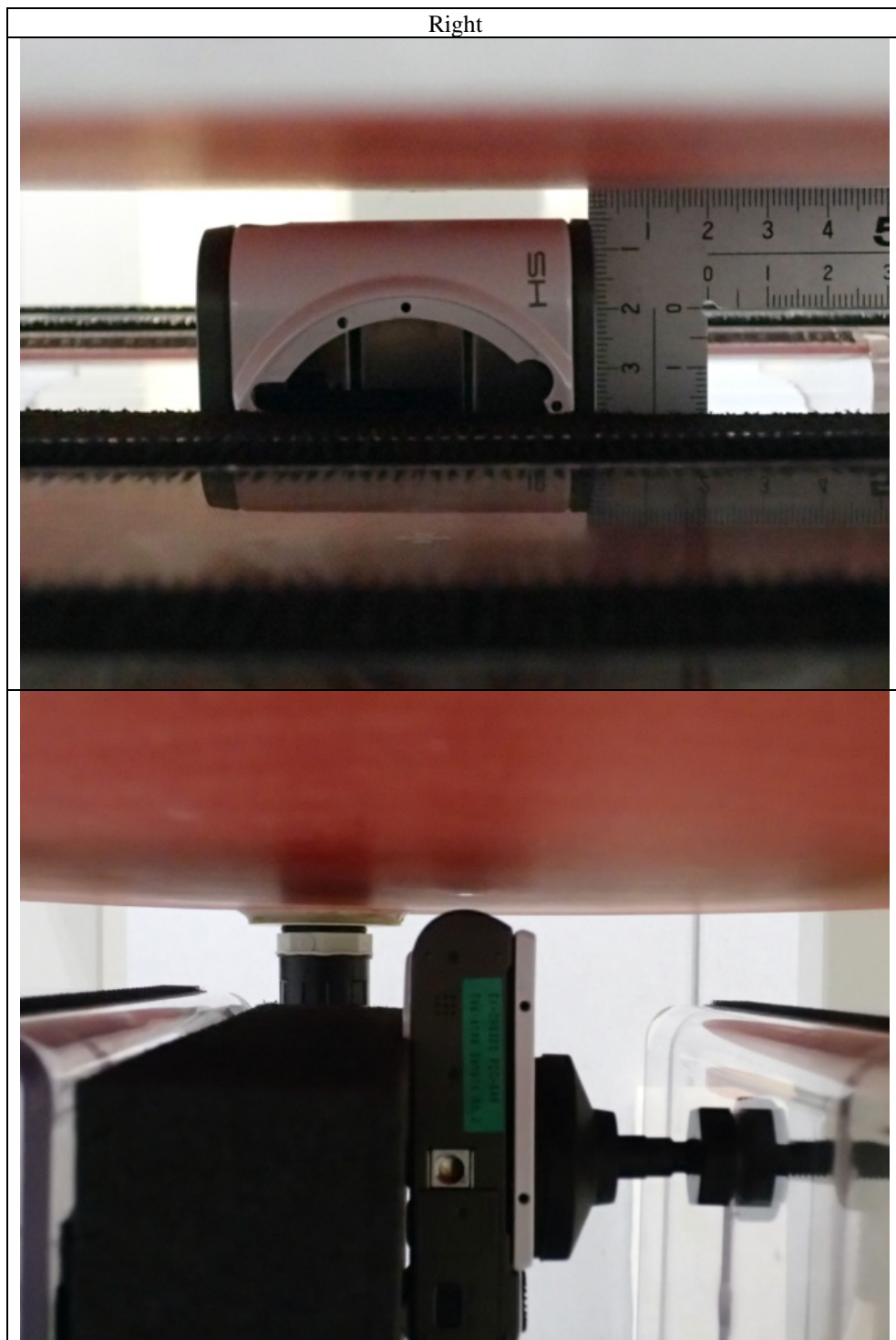

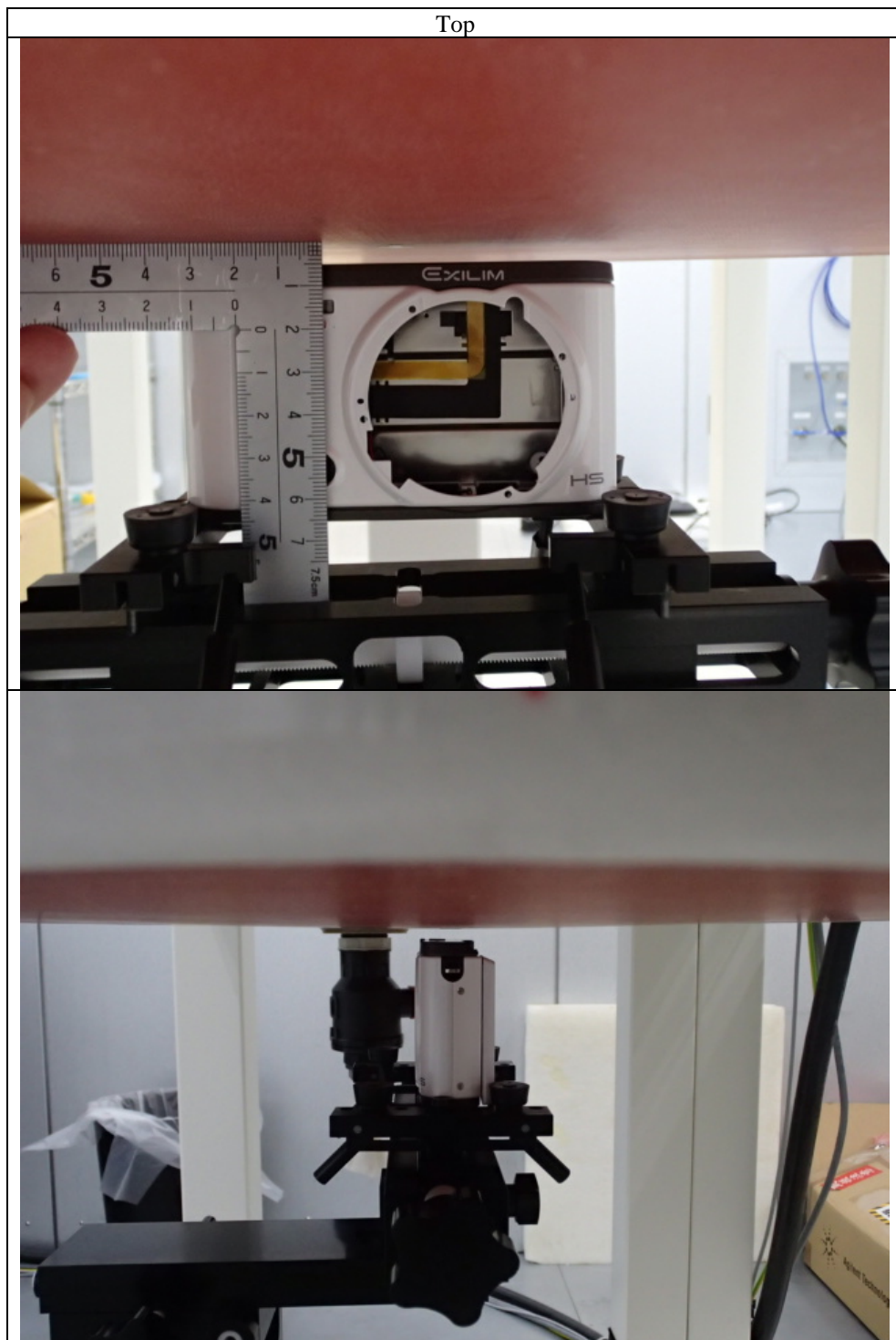

End of Report