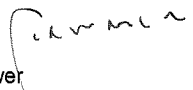

Produkte  
 Products

<b>Prüfbericht - Nr.:</b> <b>12606802 007</b>		<b>Seite 1 von 42</b> Page 1 of 42	
<i>Test Report No.:</i>			
<b>Auftraggeber:</b> <i>Client:</i>	<b>Mitsumi Electric Co Ltd</b> 1601, Sakai, Atsugi-shi. Kanagawa-ken 243, Japan		
<b>Gegenstand der Prüfung:</b> <i>Test item:</i>	<b>Wireless LAN Module</b>		
<b>Bezeichnung:</b> <i>Identification:</i>	<b>DWM-W028</b>	<b>Serien-Nr.:</b> <i>Serial No.:</i>	<b>MAC 78:A2:A0:35:D4:62</b>
<b>Wareneingangs-Nr.:</b> <i>Receipt No.:</i>	<b>PT214004061-1</b>	<b>Eingangsdatum:</b> <i>Date of receipt:</i>	<b>2010-09-13</b>
<b>Prüfört:</b> <i>Testing location:</i>	<b>TÜV Rheinland Japan Ltd. - Global Technology Assessment Center</b> 4-25-2 Kita-Yamata, Tsuzuki-ku, Yokohama 224-0021, Japan		
<b>Prüfgrundlage:</b> <i>Test specification:</i>	<b>47 CFR Part 15.207 and 15.247 (Subpart: C), 2009-10</b> <b>47 CFR Part 15.107 and 15.109 (Subpart: B), 2009-10</b> ANSI C63.4-2003 KDB Publication No. 558074: Guidance on Measurements for Digital Transmission Systems (47 CFR Part 15.247), March 23, 2005  <b>RSS-210 (Issue 7): 2007</b> <b>RSS-Gen (Issue 2): 2007</b>		
<b>Prüfergebnis:</b> <i>Test Result:</i>	<b>Der Prüfgegenstand entspricht oben genannter Prüfgrundlage(n).</b> The test item passed the test specification(s).		
<b>Prüflaboratorium:</b> <i>Testing Laboratory:</i>	<b>TÜV Rheinland Japan Ltd. - Global Technology Assessment Center</b> 4-25-2 Kita-Yamata, Tsuzuki-ku, Yokohama 224-0021, Japan		
<b>geprüft/ tested by:</b>		<b>kontrolliert/ reviewed by:</b>	
 2010-09-24 Y. Sasaki / Inspector		 2010-09-24 T. Cheung / Reviewer	
<b>Datum</b> <i>Date</i>	<b>Name/Stellung</b> <i>Name/Position</i>	<b>Unterschrift</b> <i>Signature</i>	<b>Datum</b> <i>Date</i>
			<b>Name/Stellung</b> <i>Name/Position</i>
			<b>Unterschrift</b> <i>Signature</i>
<b>Sonstiges / Other Aspects:</b>			
This test report deals with the Permissive Change II on the existing Limited Single Module of Intentional radiator 802.11b and 802.11g of the grant, details refer to Section 1: General remarks			
<b>Abkürzungen:</b>	<b>P(ass)</b> = entspricht Prüfgrundlage <b>F(ail)</b> = entspricht nicht Prüfgrundlage <b>N/A</b> = nicht anwendbar <b>N/T</b> = nicht getestet	<b>Abbreviations:</b>	<b>P(ass)</b> = passed <b>F(ail)</b> = failed <b>N/A</b> = not applicable <b>N/T</b> = not tested
<p><b>Dieser Prüfbericht bezieht sich nur auf das o.g. Prüfmuster und darf ohne Genehmigung der Prüfstelle nicht auszugsweise vervielfältigt werden. Dieser Bericht berechtigt nicht zur Verwendung eines Prüfzeichens.</b>  <i>This test report relates to the a. m. test sample. Without permission of the test center this test report is not permitted to be duplicated in extracts. This test report does not entitle to carry any safety mark on this or similar products.</i></p>			

## TEST SUMMARY

**3.2.1 VOLTAGE REQUIREMENTS, FCC 15.31(E)**

RESULT: PASS

**3.2.2 ANTENNA REQUIREMENTS, FCC 15.203, FCC 15.204 AND RSS-GEN 7.1.4**

RESULT: PASS

**5.1.1 MAINS TERMINAL CONTINUOUS DISTURBANCE VOLTAGE OF TRANSMITTER, FCC 15.207 AND RSS-GEN 7.2.2**

RESULT: PASS

**5.2.1 MAINS TERMINAL CONTINUOUS DISTURBANCE VOLTAGE OF RECEIVER, FCC 15.107 AND RSS-GEN 7.2.2**

RESULT: PASS

**6.1.1 BAND EDGE RADIATED EMISSION, FCC 15.247(D) AND RSS- 210 2.2**

RESULT: PASS

**6.1.2 RADIATED EMISSION, OUT-OF-BAND AND SPURIOUS EMISSION, FCC 15.247(D), FCC 15.205, FCC 15.209, RSS-210 2.2, RSS-210 A8.5 AND RSS-GEN 7.2.1**

RESULT: PASS

**6.2.1 RADIATED EMISSION OF RECEIVER, FCC 15.109, RSS-210 2.2, RSS-210 2.6, RSS-210 A8.5, RSS-GEN 7.2.3.2**

RESULT: PASS

Produkte  
Products

**Prüfbericht - Nr.: 12606802 007**  
Test Report No.:

Seite 3 von 42  
Page 3 of 42

## Contents

<b>1.</b>	<b>GENERAL REMARKS .....</b>	<b>5</b>
<b>1.1</b>	<b>COMPLEMENTARY MATERIALS .....</b>	<b>6</b>
<b>2.</b>	<b>TEST SITES .....</b>	<b>7</b>
<b>2.1</b>	<b>TEST FACILITIES .....</b>	<b>7</b>
<b>2.2</b>	<b>LIST OF TEST AND MEASUREMENT INSTRUMENTS .....</b>	<b>8</b>
<b>2.3</b>	<b>MEASUREMENT UNCERTAINTY .....</b>	<b>9</b>
<b>3.</b>	<b>GENERAL PRODUCT INFORMATION .....</b>	<b>10</b>
<b>3.1</b>	<b>PRODUCT FUNCTION AND INTENDED USE .....</b>	<b>10</b>
<b>3.2</b>	<b>SYSTEM DETAILS .....</b>	<b>10</b>
3.2.1	<i>Voltage Requirements, FCC 15.31(e) .....</i>	<i>11</i>
3.2.2	<i>Antenna Requirements, FCC 15.203, FCC 15.204 and RSS-Gen 7.1.4.....</i>	<i>11</i>
<b>3.3</b>	<b>CLOCK FREQUENCIES .....</b>	<b>11</b>
<b>3.4</b>	<b>INDEPENDENT OPERATION MODES .....</b>	<b>12</b>
<b>3.5</b>	<b>NOISE SUPPRESSING PARTS.....</b>	<b>13</b>
<b>4.</b>	<b>TEST SET-UP AND OPERATION MODES .....</b>	<b>14</b>
<b>4.1</b>	<b>TEST METHODOLOGY .....</b>	<b>14</b>
<b>4.2</b>	<b>PHYSICAL CONFIGURATION FOR TESTING .....</b>	<b>15</b>
<b>4.3</b>	<b>TEST OPERATION AND TEST SOFTWARE.....</b>	<b>16</b>
<b>4.4</b>	<b>SPECIAL ACCESSORIES AND AUXILIARY EQUIPMENT .....</b>	<b>16</b>
<b>4.5</b>	<b>COUNTERMEASURES TO ACHIEVE EMC COMPLIANCE.....</b>	<b>16</b>
<b>5.</b>	<b>TEST RESULTS AC MAINS CONDUCTED EMISSION .....</b>	<b>17</b>
<b>5.1</b>	<b>AC MAINS CONDUCTED EMISSION OF TRANSMITTER .....</b>	<b>17</b>
5.1.1	<i>Mains Terminal Continuous Disturbance Voltage of Transmitter, FCC 15.207 and RSS-Gen</i>	
5.1.2	<i>17</i>	
<b>5.2</b>	<b>AC MAINS CONDUCTED EMISSION OF RECEIVER.....</b>	<b>20</b>
5.2.1	<i>Mains Terminal Continuous Disturbance Voltage of Receiver, FCC 15.107 and RSS-Gen 7.2.220</i>	
<b>6.</b>	<b>TEST RESULTS RADIATED EMISSION .....</b>	<b>22</b>
<b>6.1</b>	<b>RADIATED EMISSION OF TRANSMITTER .....</b>	<b>22</b>
6.1.1	<i>Band Edge Radiated Emission, FCC 15.247(d) and RSS-210 2.2 .....</i>	<i>22</i>
6.1.2	<i>Radiated Emission, Out-of-Band and Spurious Emission, FCC 15.247(d), FCC 15.205, FCC</i>	
	<i>15.209, RSS-210 2.2, RSS-210 A8.5 and RSS-Gen 7.2.1.....</i>	<i>27</i>
<b>6.2</b>	<b>RADIATED EMISSION OF RECEIVER.....</b>	<b>34</b>
6.2.1	<i>Radiated Emission of Receiver, FCC 15.109, RSS-210 2.2, RSS-210 2.6, RSS-210 A8.5,</i>	
	<i>RSS-Gen 7.2.3.2.....</i>	<i>34</i>

**Produkte**  
Products

**Prüfbericht - Nr.: 12606802 007**

**Seite 4 von 42**

*Test Report No.:*

*Page 4 of 42*

<b>7.</b>	<b>PHOTOGRAPHS OF TEST SETUP .....</b>	<b>36</b>
<b>8.</b>	<b>LIST OF TABLES.....</b>	<b>41</b>
<b>9.</b>	<b>LIST OF FIGURES .....</b>	<b>41</b>
<b>10.</b>	<b>LIST OF PHOTOGRAPHS.....</b>	<b>42</b>

## 1. General Remarks

It is a permissive change project which is classified as **Permissive Change II** for the existing FCC Grant (FCC ID: EW4DWMW028) and as modification for IC certificate (IC: 4250A-DWMW028) by additional antennas and host CTR-001 are applied to this Limited Modular Approval.

### 1. Additional antennas:

Original certified antenna:

DCA-P08 (only for Nintendo DS CTR Target Board),  
DCA-P17 ES3, DCA-P17 ES4 and DCA-P17 CS (for CTR-001(-01))

Test report 12606802 005 and 006 tested antenna:

361.00194.005 CS

(not certified yet, it will certify together with DCA-P17 CS2 and 361.00194.005 CS2.

Details refer to 12606802 005 and 12606802 006)

### **Additional antenna (current):**

DCA-P17 CS2 and 361.00194.005 CS2

Antennas DCA-P17 CS2 and 361.00194.005 CS2 are added for the host (CTR-001 / CTR-001(-01)).

- a. The type of the antenna 361.00194.005 CS is the same as that of 361.00194.005 CS2. Since the antenna gain of 361.00194.005 CS is higher than that of 361.00194.005 CS2, **no additional test** is considered to **361.00194.005 CS2**.
- b. But **additional test** will be considered to the antenna **DCA-P17 CS2**, because the antenna gain of DCA-P17 CS2 is higher than that of DCA-P17 series antenna.

### 2. Additional host:

Original certified hosts: Nintendo DS CTR Target Board and CTR-001(-01)

**Additional host:** CTR-001

CTR-001 is for production, and CTR-001(-01) is for development.

CTR-001 is identical to CTR-001(-01) except security function of program.

CTR-001(-01) will be selected as representative host to test with the module DWM-W028, since the security function of program does not significantly affect the radio and EMC behavior.

Therefore, all the antennas will also be applied with CTR-001 except antenna DCA-P08

Conducted Emission and Radiated Emission were conducted due to the above changes. Refer to the exhibits for the technical details of the changes. Previous technical test data of the module refer to the test report of the original application.

Unintentional (receiver only) radiator of the tested product is considered in the test report.

The test is only covered the radio operation mode will be tested under Class B. The other digital interface operation is handled by customer under Class A.

Produkte  
 Products

**Prüfbericht - Nr.: 12606802 007**

Seite 6 von 42  
 Page 6 of 42

Test Report No.:

The history of the module is shown as follow:

Test report number	Content
12606802 001	Original Application Host: Nintendo DS CTR Target Board Antenna: DCA-P08
12606802 002	Original Application RF Exposure report
12606802 003	Permissive change II Application Additional host: CTR-001(-01) Additional antenna: DCA-P17 ES3, DCA-P17 ES4 and DCA-P17 CS
12606802 004	Permissive change II Application RF Exposure report
12606802 005	Permissive change II Application Additional antenna: Antenna 361.00194.005 CS for the host CTR-001(-01). Antenna CS (DCA-P17 CS), ES3 (DCA-P17 ES3) and ES4 (DCA-P17 ES4) are still used.  Modification of the host CTR-001(-01): In the schematic, minor changes of the capacitor, resistor and diode are made by adding or deleting or changing values. Fundamental circuit does not change. Artwork is changed based on schematic change. The locations of major parts(IC, module, connector, etc) are same. Details refer to the exhibits
12606802 006	Permissive change II Application RF Exposure report
12606802 007	Permissive change II Application Refer to section 1 for details
12606802 008	Permissive change II Application RF Exposure report

## 1.1 Complementary Materials

There is no attachment of this test report.

## **2. Test Sites**

### **2.1 Test Facilities**

TÜV Rheinland Japan Ltd. - Global Technology Assessment Center  
4-25-2 Kita-Yamata, Tsuzuki-ku, Yokohama 224-0021, Japan

The used test equipment is in accordance with CISPR 16 for measurement of radio interference.

The Federal Communications Commission has reviewed the technical characteristics of the radiated and conducted emission facility, and has found these test facilities to be in compliance with the requirements of section 2.948 of the FCC rules. The description of the test facility is listed under FCC registration number 299054.

The Industry Canada has reviewed the technical characteristics of the radiated and conducted emission facility, and has found these test facilities to be in compliance. The description of the test facility is listed under OATS filing number 3466B.

The test facility is accredited by VLAC (member of ILAC) under number VLAC-017 according to ISO/IEC 17025:2005. TÜV Rheinland Japan Ltd. is accredited by the Federal Communications Commission as a Conformity Assessment Body under Designation Number JP0017 and Test Firm Registration Number 386498.

## 2.2 List of Test and Measurement Instruments

**Table 1: List of Test and Measurement Equipment**

Kind of Equipment	Manufacturer	Model Name	Serial Number	Equipment ID	Calibrated until
<b>For AC Mains Conducted Emission (CE)</b>					
Receiver	Rohde & Schwarz	ESU 8	100025	RF-0020	2011-02
LISN	Rohde & Schwarz	ENV216	100276	RF-0016	2011-06
<b>For Radiated Emission (RE)</b>					
Receiver	Rohde & Schwarz	ESU 8	100025	RF-0020	2011-02
Receiver	Rohde & Schwarz	ESU 40	100029	RF-0021	2010-12
RF Selector (10m)	Toyo Corporation	NS4900	0703-182	RF-0029	2011-05
3dB Attenuator 50Ohm	Tamagawa Electronics Co., Ltd.	CFA-01	-	RF-0265	2011-05
Low Noise Pre-Amplifier	TSJ	MLA-10K01-B01-35	1370750	RF-0253	2010-11
Microwave Pre-Amplifier, 1-8GHz	Toyo Corporation	TPA0108-40	0634	RF-0052	2010-11
Band Reject Filter	Nitsuki	NF-49BT	027	RF-0131	2010-11
Trilog Antenna, 30-1000MHz	Schwarzbeck	VULB9168	0245	RF-0019	2011-05
Horn Antenna, 1-10GHz	Schwarzbeck	BBHA9120B	419	RF-0050	2011-05
Horn Antenna with Pre-Amplifier, 2-18GHz (RX)	Toyo Corporation	HAP06-18W	00000025	RF-0065	2011-05
Horn Antenna with Pre-Amplifier, 18-26.5GHz (RX)	Toyo Corporation	HAP18-26N	00000010	RF-0070	2011-05
Band pass Filter	Micro-Tronics	HPM50107	006	RF-0334	2011-05
<b>Constant Voltage Constant Frequency Stabilizers</b>					
CVCF (Shielded Room)	NF Corporation	ESU2000S	9075612	RF-0210	N/A
CVCF Booster (Shielded Room)	NF Corporation	ESU2000B	9074403	RF-0211	N/A
CVCF (10m chamber)	NF Corporation	ESU2000S	9067307	RF-0212	N/A
CVCF Booster (10m chamber)	NF Corporation	ESU2000B	9074408	RF-0213	N/A



## 2.3 Measurement Uncertainty

**Table 2: Emission Measurement Uncertainty**

Measurement Type	Frequency	Uncertainty
AC Power Line Conducted Emission	150kHz - 30MHz	±3.0dB
Radiated Emission	30MHz - 1GHz	±4.7dB
	> 1GHz	±4.5dB

### 3. General Product Information

#### 3.1 Product Function and Intended Use

The **EUT** (Equipment Under Test) is a Wireless LAN Module certified as Limited Module Approval (FCC ID: EW4DWMW028 and IC: 4250A-DWMW028). The module consists of radios 802.11b/g. 802.11b at 1/2Mbps supports NDS series. 802.11b/g supports Nintendo Wii. The two radios cannot transmit at the same time.

#### 3.2 System Details

Radio standard:	IEEE 802.11b/g
Specified power output:	8.26dBm (Peak), 4.38dBm (Average) for 802.11b 14.82dBm (Peak), 4.71dBm (Average) for 802.11g
Antenna gain:	-1.91dBi (DCA-P08) for Nintendo DS CTR Target Board -6.52dBi (DCA-P17 ES3) for CTR-001(-01) -6.20dBi (DCA-P17 ES4) for CTR-001(-01) -6.35dBi (DCA-P17 CS) for CTR-001(-01) +1.15dBi (361.00194.005 CS) for CTR-001(-01) -5.39dBi (DCA-P17 CS2) for CTR-001 / CTR-001(-01) -5.10dBi (361.00194.005 CS2) for CTR-001 / CTR-001(-01)
Antenna type:	Inverted F antenna (DCA-P08 and DCA-P17 series) Dipole antenna (361.00194.005 CS and CS2)
Mounting type:	External, fixed location
Frequency range:	2412 – 2472 MHz
Number of channel:	13
Channel spacing:	5 MHz
Modulation type:	BPSK, QPSK, CCK (802.11b) BPSK, QPSK, 16 QAM, 64 QAM (802.11g)
FCC Classification:	DTS
Emission designator:	G1D
System Input rating:	DC 4.6V or AC 110-240V, 50/60Hz via AC adaptor
Protection Class:	II
Test voltage:	AC 120V
Test frequency:	60Hz

Remark: Different antenna is for different kinds of the certified typical host. Details refer to the section 1.

**Table 3: Interfaces present on the EUT**

No.	Interface	Cable Length for Testing, Shielding	Interface Classification
1.	AC Mains input [AC Mains -> AC/DC adaptor]	1.5m, un-shielded	AC Power Input Port
2.	DC power input [AC/DC adaptor -> Host]	0.9m, un-shielded	DC Power Input Port

### 3.2.1 Voltage Requirements, FCC 15.31(e)

**RESULT:** **PASS**

The EUT has an external voltage regulator to supply the RF circuit in the host. Hence it complies with the power supply requirements.

### 3.2.2 Antenna Requirements, FCC 15.203, FCC 15.204 and RSS-Gen 7.1.4

**RESULT:** **PASS**

The EUT has a permanent external antenna, details refer to the exhibits.

### 3.3 Clock Frequencies

The highest clock frequency generated by the EUT is 40 MHz

### 3.4 Independent Operation Modes

The EUT was tested with the host. The test system was configured for testing in a typical fashion (as a customer would normally use it).

The justification and manipulation of cables and equipment in order to simulate a worst-case behavior of the test setup has been carried out as prescribed in ANSI C63.4:2003. Testing was performed at the lowest operating frequency (2412 MHz), the operating frequency in the middle of the specified frequency band (2442 MHz) and the highest operating frequency (2472 MHz).

The basic operation modes are:

#### 802.11b radio

- b1. EUT continuously transmits at lowest Channel (2412 MHz)
- b2. EUT continuously transmits at middle Channel (2442 MHz)
- b3. EUT continuously transmits at highest Channel (2472 MHz)

#### 802.11g radio

- g1. EUT continuously transmits at lowest Channel (2412 MHz)
- g2. EUT continuously transmits at middle Channel (2442 MHz)
- g3. EUT continuously transmits at highest Channel (2472 MHz)

R. EUT receives packets with 802.11b/gradio

All continuous modulated signals are streaming with 100% duty cycle.

The worst-case data rate for each mode is determined as follows, based on preliminary test of above radios.

**Table 4: The Data rate corresponds the worst case of each frequency band of different radio**

Channel	Modulation/ Data Rate(Mbps)	
	802.11b	802.11g
Lowest: 2412MHz	11	12
Middle: 2442MHz	11	18
Highest: 2472MHz	1	24

The worst-case position was investigated for X, Y, Z orientation and movable antenna with highest emission, the worst-position was Y orientation below 1GHz and X orientation above 1GHz with the movable antenna (nearly right angle) shown in Photograph 4. Therefore, all tests were conducted in X and Y orientation for particular frequency range.

### **3.5 Noise Suppressing Parts**

Refer to the schematic

## **4. Test Set-up and Operation Modes**

### **4.1 Test Methodology**

The test methodology used is based on the requirements of 47 CFR Part 15, sections 15.31, 15.33, 15.35, 15.205, 15.209 and Measurement of Digital Transmission Systems Operating under Section 15.247.

The test methods, which have been used, are based on ANSI C63.4:2003 and RSS-Gen (Issue 2).

For details, see under each test item.

## 4.2 Physical Configuration for Testing

Figure 1: Test setup

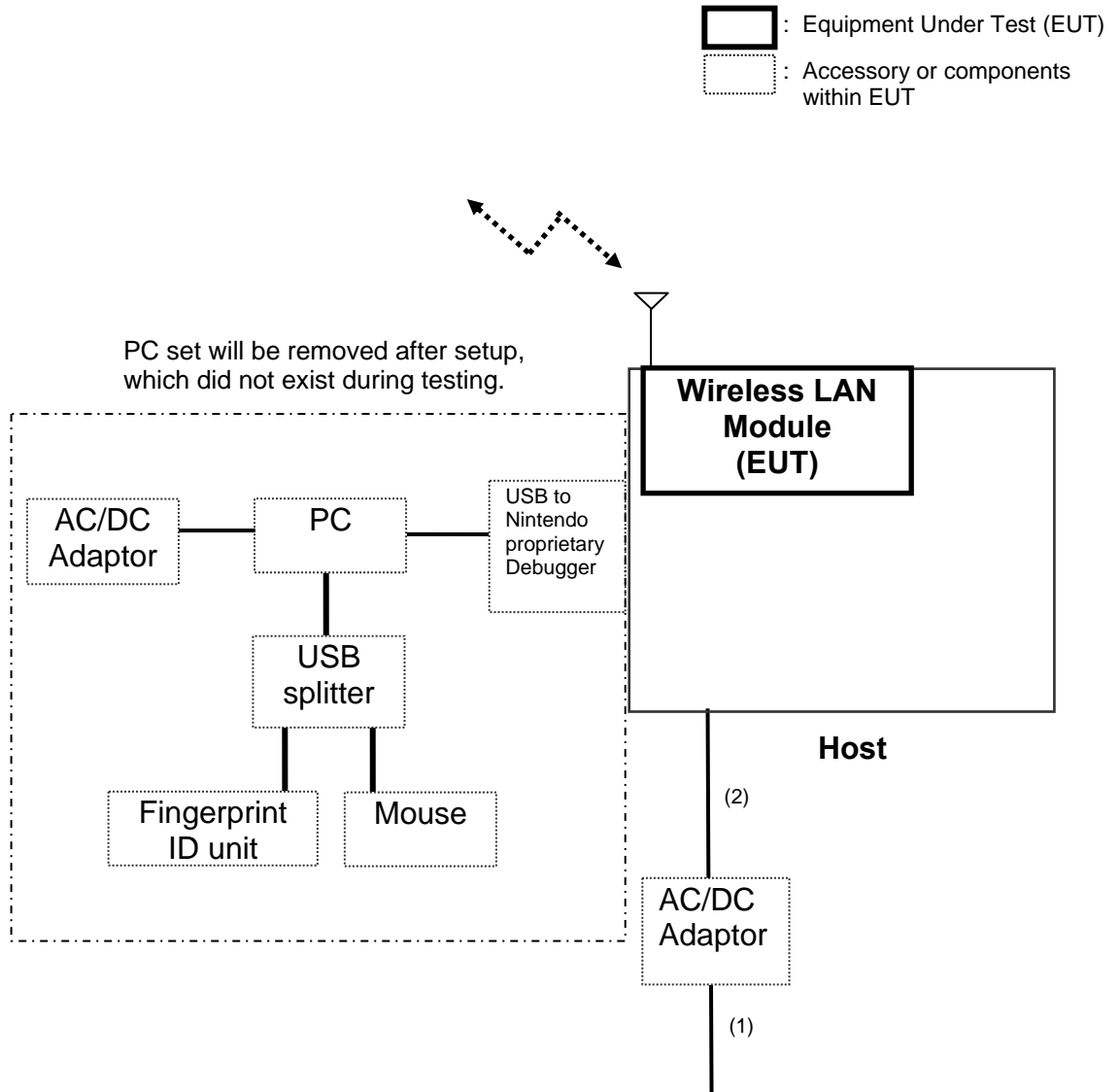

Note: The PC is necessary for operation mode setting. The PC can be disconnected after the setting is successful.

For more details, refer to section: Photographs of the Test Set-Up.

### 4.3 Test Operation and Test Software

Following software was used for testing provided by Nintendo Co., Ltd.

1. The test program used for 11b/g test is "HOSTIO-ART"..  
HOSTIO-ART consists of the software on PC.  
The version of "HOSTIO-ART" is 1.8.

The software is used to enable on the EUT the test operation mode specified in section 3.4 as appropriate.

### 4.4 Special Accessories and Auxiliary Equipment

The product has been tested together with the following additional accessories:

1. Product: Host (Portable Game Machine)  
Manufacturer: Nintendo Co., Ltd.  
Model: CTR-001(-01)  
Rated voltage: DC 3.6-3.7V (Battery), DC 4.6V (via Adaptor)  
Rated current: 900mA  
Protection class:III  
Serial number: AAA400014386
2. Product: AC Adapter for the Host  
Manufacturer: Nintendo Co., Ltd.  
Model: WAP-002(USA)  
Rating: AC 120V (input)/ DC 4.6V (output)  
Input power: 7W  
Frequency: 60Hz  
Protection class:II  
Serial number: C3FT101

### 4.5 Countermeasures to achieve EMC Compliance

None



## 5. Test Results AC Mains Conducted Emission

### 5.1 AC Mains Conducted Emission of Transmitter

#### 5.1.1 Mains Terminal Continuous Disturbance Voltage of Transmitter, FCC 15.207 and RSS-Gen 7.2.2

**RESULT:** **PASS**

Date of testing: 2010-09-15

Ambient temperature: 25°C

Relative humidity: 61%

Atmospheric pressure: 1013hPa

Frequency range: 0.15 – 30MHz

Kind of test site: Shielded Room

**Requirements:**

The AC power line on any frequency within the band 150 kHz to 30MHz shall not exceed the limits specified in FCC 15.207 and RSS-Gen 7.2.2.

**Test procedure:**

ANSI C63.4-2003

The EUT was placed on a wooden table raised 80cm above the reference ground plane. A vertical conducting plane of the screened room was located 40cm to the rear of the EUT. The AC adapter of the laptop computer was connected to a Line Impedance Stabilization Network (LISN) / Artificial Mains Network (AMN).

The physical arrangement of the test system and associated cabling was varied in order to determine the effect on the EUT's emissions in amplitude and frequency in order to ensure that maximum emission amplitudes were attained.

The measurements were performed with the spectrum analyzer operating in the CISPR quasi-peak and average detection modes. The analyzer's 6 dB bandwidth was set to 9kHz. No video filter less than 10 times the resolution bandwidth was used.

Disturbances other than those mentioned are small or not detectable.

Produkte  
 Products

**Prüfbericht - Nr.: 12606802 007**

Seite 18 von 42

Test Report No.:

Page 18 of 42

**Table 5: Conducted Emission, 150kHz – 30MHz, Quasi Peak and Average Data, Phase N (N) and L1 (L), Mode b1, 802.11b**

Freq. [MHz]	Phase	Reading QP [dB(µV)]	Reading AV [dB(µV)]	Factor [dB]	Level QP [dB(µV)]	Level AV [dB(µV)]	Limit QP [dB(µV)]	Limit AV [dB(µV)]	Margin QP [dB]	Margin AV [dB]
1.20252	N	28.7	15.9	9.7	38.4	25.6	56.0	46.0	17.6	20.4
1.42000	N	32.8	15.9	9.7	42.5	25.6	56.0	46.0	13.5	20.4
1.58815	N	29.1	13.7	9.7	38.8	23.4	56.0	46.0	17.2	22.6
1.77604	N	26.5	9.9	9.7	36.2	19.6	56.0	46.0	19.8	26.4
0.19717	L1	33.1	22.7	9.7	42.8	32.4	63.7	53.7	20.9	21.3
0.40458	L1	28.3	17.6	9.7	38.0	27.3	57.8	47.8	19.8	20.5
1.21459	L1	29.6	14.1	9.7	39.3	23.8	56.0	46.0	16.7	22.2
1.41775	L1	35.8	19.8	9.7	45.5	29.5	56.0	46.0	10.5	16.5
1.52464	L1	28.4	0.7	9.7	38.1	10.4	56.0	46.0	17.9	35.6
1.58090	L1	32.4	15.0	9.7	42.1	24.7	56.0	46.0	13.9	21.3
1.68599	L1	16.1	-7.6	9.7	25.8	2.1	56.0	46.0	30.2	43.9
1.73000	L1	28.1	2.3	9.7	37.8	12.0	56.0	46.0	18.2	34.0
1.80284	L1	32.6	18.1	9.7	42.3	27.8	56.0	46.0	13.7	18.2
3.21158	L1	24.1	9.2	9.8	33.9	19.0	56.0	46.0	22.1	27.0
7.62369	L1	26.9	10.6	10.0	36.9	20.6	60.0	50.0	23.1	29.4
9.54698	L1	25.7	8.7	10.1	35.8	18.8	60.0	50.0	24.2	31.2

Notes: Level QP = Reading QP + Factor  
 Level AV = Reading AV + Factor

**Table 6: Conducted Emission, 150kHz – 30MHz, Quasi Peak and Average Data, Phase N (N) and L1 (L), Mode b3, 802.11b**

Freq. [MHz]	Phase	Reading QP [dB(µV)]	Reading AV [dB(µV)]	Factor [dB]	Level QP [dB(µV)]	Level AV [dB(µV)]	Limit QP [dB(µV)]	Limit AV [dB(µV)]	Margin QP [dB]	Margin AV [dB]
1.21860	N	28.8	11.5	9.7	38.5	21.2	56.0	46.0	17.5	24.8
1.40969	N	32.2	20.4	9.7	41.9	30.1	56.0	46.0	14.1	15.9
1.41793	N	32.9	18.6	9.7	42.6	28.3	56.0	46.0	13.4	17.7
1.62338	N	31.8	14.9	9.7	41.5	24.6	56.0	46.0	14.5	21.4
1.78644	N	26.3	10.8	9.7	36.0	20.5	56.0	46.0	20.0	25.5
0.40318	L1	28.1	18.5	9.7	37.8	28.2	57.8	47.8	20.0	19.6
1.21297	L1	29.2	15.4	9.7	38.9	25.1	56.0	46.0	17.1	20.9
1.38901	L1	32.6	16.0	9.7	42.3	25.7	56.0	46.0	13.7	20.3
1.40167	L1	35.4	21.2	9.7	45.1	30.9	56.0	46.0	10.9	15.1
1.62180	L1	35.0	18.0	9.7	44.7	27.7	56.0	46.0	11.3	18.3
1.76482	L1	29.4	9.7	9.7	39.1	19.4	56.0	46.0	16.9	26.6
3.22018	L1	24.0	8.9	9.8	33.8	18.7	56.0	46.0	22.2	27.3
7.46297	L1	25.6	10.4	10.0	35.6	20.4	60.0	50.0	24.4	29.6
9.62554	L1	26.5	11.5	10.1	36.6	21.6	60.0	50.0	23.4	28.4
10.49745	L1	25.9	10.5	10.1	36.0	20.6	60.0	50.0	24.0	29.4

Notes: Level QP = Reading QP + Factor  
 Level AV = Reading AV + Factor

Produkte  
 Products

**Prüfbericht - Nr.: 12606802 007**

Seite 19 von 42

Test Report No.:

Page 19 of 42

**Table 7: Conducted Emission, 150kHz – 30MHz, Quasi Peak and Average Data, Phase N (N) and L1 (L), Mode g1, 802.11g**

Freq. [MHz]	Phase	Reading QP [dB(µV)]	Reading AV [dB(µV)]	Factor [dB]	Level QP [dB(µV)]	Level AV [dB(µV)]	Limit QP [dB(µV)]	Limit AV [dB(µV)]	Margin QP [dB]	Margin AV [dB]
1.20405	N	28.7	14.0	9.7	38.4	23.7	56.0	46.0	17.6	22.3
1.37491	N	29.9	14.5	9.7	39.6	24.2	56.0	46.0	16.4	21.8
1.37982	N	30.2	15.0	9.7	39.9	24.7	56.0	46.0	16.1	21.3
1.57734	N	29.1	14.1	9.7	38.8	23.8	56.0	46.0	17.2	22.2
1.74653	N	26.1	8.1	9.7	35.8	17.8	56.0	46.0	20.2	28.2
1.77532	N	26.3	11.5	9.7	36.0	21.2	56.0	46.0	20.0	24.8
0.39159	L1	27.2	14.6	9.7	36.9	24.3	58.0	48.0	21.1	23.7
1.20194	L1	28.9	14.2	9.7	38.6	23.9	56.0	46.0	17.4	22.1
1.40099	L1	35.1	21.1	9.7	44.8	30.8	56.0	46.0	11.2	15.2
1.53581	L1	30.6	5.6	9.7	40.3	15.3	56.0	46.0	15.7	30.7
1.55824	L1	31.8	13.6	9.7	41.5	23.3	56.0	46.0	14.5	22.7
1.68847	L1	27.2	-1.0	9.7	36.9	8.7	56.0	46.0	19.1	37.3
1.74626	L1	29.5	10.3	9.7	39.2	20.0	56.0	46.0	16.8	26.0
1.91613	L1	22.3	-1.9	9.7	32.0	7.8	56.0	46.0	24.0	38.2
3.19923	L1	23.6	9.1	9.8	33.4	18.9	56.0	46.0	22.6	27.1
7.53311	L1	27.0	10.3	10.0	37.0	20.3	60.0	50.0	23.0	29.7
10.03013	L1	28.4	11.2	10.1	38.5	21.3	60.0	50.0	21.5	28.7

Notes: Level QP = Reading QP + Factor  
 Level AV = Reading AV + Factor

**Table 8: Conducted Emission, 150kHz – 30MHz, Quasi Peak and Average Data, Phase N (N) and L1 (L), Mode g3, 802.11g**

Freq. [MHz]	Phase	Reading QP [dB(µV)]	Reading AV [dB(µV)]	Factor [dB]	Level QP [dB(µV)]	Level AV [dB(µV)]	Limit QP [dB(µV)]	Limit AV [dB(µV)]	Margin QP [dB]	Margin AV [dB]
1.20982	N	28.8	16.0	9.7	38.5	25.7	56.0	46.0	17.5	20.3
1.39068	N	30.1	15.7	9.7	39.8	25.4	56.0	46.0	16.2	20.6
1.61478	N	31.3	18.4	9.7	41.0	28.1	56.0	46.0	15.0	17.9
1.72410	N	24.9	-1.2	9.7	34.6	8.5	56.0	46.0	21.4	37.5
0.19985	L1	34.0	24.5	9.7	43.7	34.2	63.6	53.6	19.9	19.4
0.40290	L1	28.1	18.4	9.7	37.8	28.1	57.8	47.8	20.0	19.7
0.60507	L1	23.4	11.6	9.7	33.1	21.3	56.0	46.0	22.9	24.7
1.22014	L1	28.0	8.7	9.7	37.7	18.4	56.0	46.0	18.3	27.6
1.41856	L1	34.9	18.4	9.7	44.6	28.1	56.0	46.0	11.4	17.9
1.56900	L1	31.3	11.9	9.7	41.0	21.6	56.0	46.0	15.0	24.4
1.81568	L1	31.7	17.7	9.7	41.4	27.4	56.0	46.0	14.6	18.6
1.99415	L1	24.3	8.4	9.7	34.0	18.1	56.0	46.0	22.0	27.9
3.24910	L1	25.0	4.6	9.8	34.8	14.4	56.0	46.0	21.2	31.6
7.61590	L1	27.4	10.2	10.0	37.4	20.2	60.0	50.0	22.6	29.8
9.60671	L1	26.6	11.4	10.1	36.7	21.5	60.0	50.0	23.3	28.5
10.50756	L1	25.5	9.9	10.1	35.6	20.0	60.0	50.0	24.4	30.0

Notes: Level QP = Reading QP + Factor  
 Level AV = Reading AV + Factor

## 5.2 AC Mains Conducted Emission of Receiver

### 5.2.1 Mains Terminal Continuous Disturbance Voltage of Receiver, FCC 15.107 and RSS-Gen 7.2.2

**RESULT:** **PASS**

Date of testing:	2010-09-15
Ambient temperature:	25°C
Relative humidity:	61%
Atmospheric pressure:	1013hPa
Frequency range:	0.15 – 30MHz
Kind of test site:	Shielded Room

**Requirements:**

The AC power line on any frequency within the band 150 kHz to 30MHz shall not exceed the limits specified in FCC 15.107(a) and RSS-Gen 7.2.2.

**Test procedure:**

ANSI C63.4-2003

The EUT was placed on a wooden table raised 80cm above the reference ground plane. A vertical conducting plane of the screened room was located 40cm to the rear of the EUT. The AC adapter of the laptop computer was connected to a Line Impedance Stabilization Network (LISN) / Artificial Mains Network (AMN).

The physical arrangement of the test system and associated cabling was varied in order to determine the effect on the EUT's emissions in amplitude and frequency in order to ensure that maximum emission amplitudes were attained.

The measurements were performed with the spectrum analyzer operating in the CISPR quasi-peak and average detection modes. The analyzer's 6 dB bandwidth was set to 9kHz. No video filter less than 10 times the resolution bandwidth was used.

Disturbances other than those mentioned are small or not detectable.

Produkte  
 Products

**Prüfbericht - Nr.: 12606802 007**  
 Test Report No.:

**Seite 21 von 42**  
 Page 21 of 42

**Table 9: Conducted Emission, 150kHz – 30MHz, Quasi Peak and Average Data, Phase N (N) and L1 (L), Mode R, 802.11b/g**

Freq. [MHz]	Phase	Reading QP [dB(µV)]	Reading AV [dB(µV)]	Factor [dB]	Level QP [dB(µV)]	Level AV [dB(µV)]	Limit QP [dB(µV)]	Limit AV [dB(µV)]	Margin QP [dB]	Margin AV [dB]
1.44986	N	32.5	16.3	9.7	42.2	26.0	56.0	46.0	13.8	20.0
0.20499	L1	33.8	24.9	9.7	43.5	34.6	63.4	53.4	19.9	18.8
1.24671	L1	28.9	8.5	9.7	38.6	18.2	56.0	46.0	17.4	27.8
1.44982	L1	35.2	18.0	9.7	44.9	27.7	56.0	46.0	11.1	18.3
1.59261	L1	30.3	5.7	9.7	40.0	15.4	56.0	46.0	16.0	30.6
1.62018	L1	31.8	15.1	9.7	41.5	24.8	56.0	46.0	14.5	21.2
1.86149	L1	31.7	15.6	9.7	41.4	25.3	56.0	46.0	14.6	20.7
3.29973	L1	24.9	9.7	9.8	34.7	19.5	56.0	46.0	21.3	26.5
7.77779	L1	28.9	11.2	10.0	38.9	21.2	60.0	50.0	21.1	28.8
9.29937	L1	27.0	11.0	10.1	37.1	21.1	60.0	50.0	22.9	28.9

Notes: Level QP = Reading QP + Factor  
 Level AV = Reading AV + Factor

## 6. Test Results Radiated Emission

### 6.1 Radiated Emission of Transmitter

#### 6.1.1 Band Edge Radiated Emission, FCC 15.247(d) and RSS- 210 2.2

**RESULT:**

**PASS**

Date of testing: 2010-09-13

Ambient temperature: 22°C

Relative humidity: 67%

Atmospheric pressure: 1000hPa

Measurement distance: 3m

Kind of test site: Semi Anechoic Chamber

Requirements:

Radiated emissions which fall in the restricted bands, as defined in FCC 15.205(a) and RSS-210 2.7 (Table 1), must comply with the radiated emission limits specified in FCC 15.209(a) and RSS-210 2.7 (Table 2 and 3).

Test procedure:

ANSI C63.4-2003, RSS-Gen 4.9, 4.10 and Measurement of Digital Transmission Systems Operating under Section 15.247

Measurements were made in a Semi Anechoic Chamber at a measurement distance of 3m. The EUT was placed on a nonconductive turntable 0.8m above the ground plane. The EUT was rotated 360°, and the antenna was raised and lowered from 1 to 4 meters in order to determine the emission's maximum level.

Pre-check measurements were taken using both horizontal and vertical antenna polarizations for host orientations (X, Y and Z) and movable antenna in order to ensure that maximum emission amplitudes were attained.

Peak (1 MHz RBW/VBW) and average (1 MHz RBW/10 Hz VBW) radiated measurements were taken with a suitable span to encompass the peak of the fundamental.

The highest emission amplitudes relative to the appropriate limit were measured and recorded in this report.

Produkte  
 Products

Prüfbericht - Nr.: **12606802 007**  
 Test Report No.:

Seite 23 von 42  
 Page 23 of 42

**Table 10: Band Edge Radiated Emission, 802.11b**

Operating Frequency [MHz]	EUT / Antenna Orient.	Average Value [dBuV/m]	Peak Value [dBuV/m]	Average Limit [dBuV/m]	Peak Limit [dBuV/m]	Average Margin [dB]	Peak Margin [dB]
2412	Y/V	32.79	46.91	54.00	74.00	21.21	27.09
2472	X/H	40.87	49.37	54.00	74.00	13.13	24.63

Notes: All correction factors (antenna, cable, pre-amplifier) are included in the measurement values.  
 Average limit in dBuV/m is calculated as follows: Average limit = 20 x log(500uV/m).  
 Peak limit in dBuV/m is calculated as follows: Peak limit = Average limit + 20dB.

**Figure 2: Band Edge Radiated Emission, Mode b1 (2412MHz), Peak and Average**

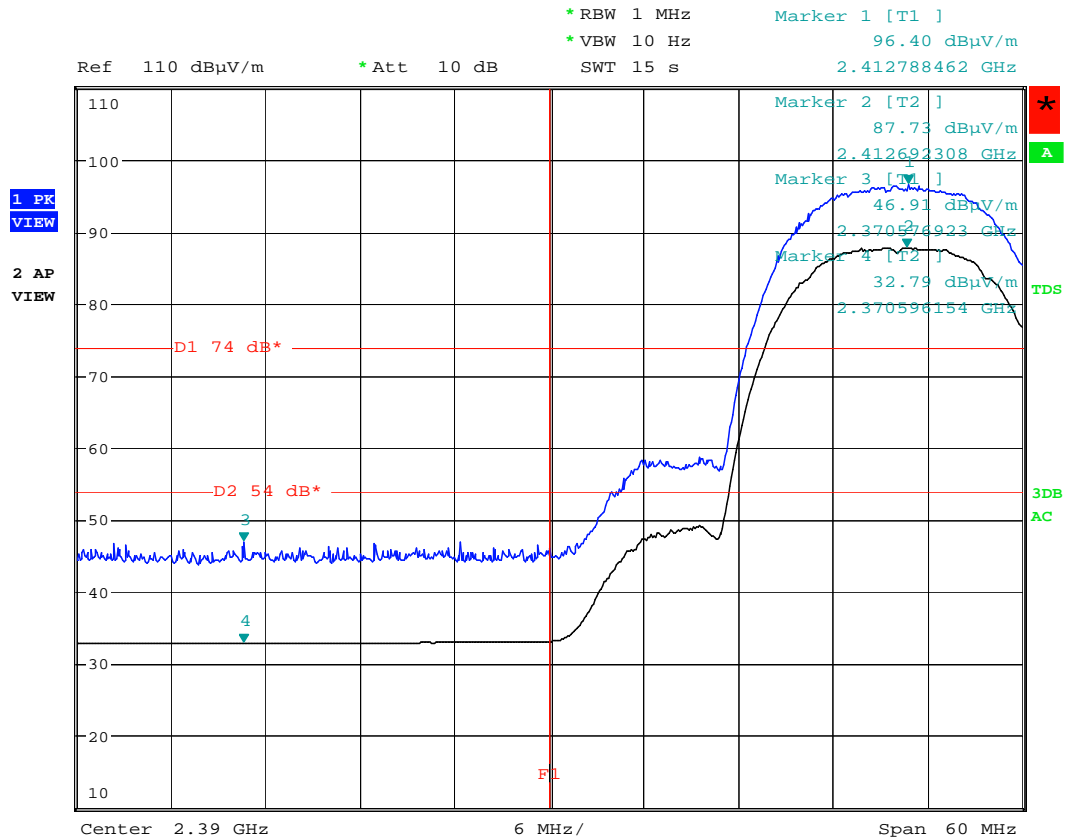

Band Edge, Mode b1  
 Date: 13.SEP.2010 11:26:25

Note: The upper trace shows the peak value and the lower trace shows the average value.

Produkte  
 Products

Prüfbericht - Nr.: 12606802 007  
 Test Report No.:

Seite 24 von 42  
 Page 24 of 42

Figure 3: Band Edge Radiated Emission, Mode b3 (2472MHz), Peak and Average

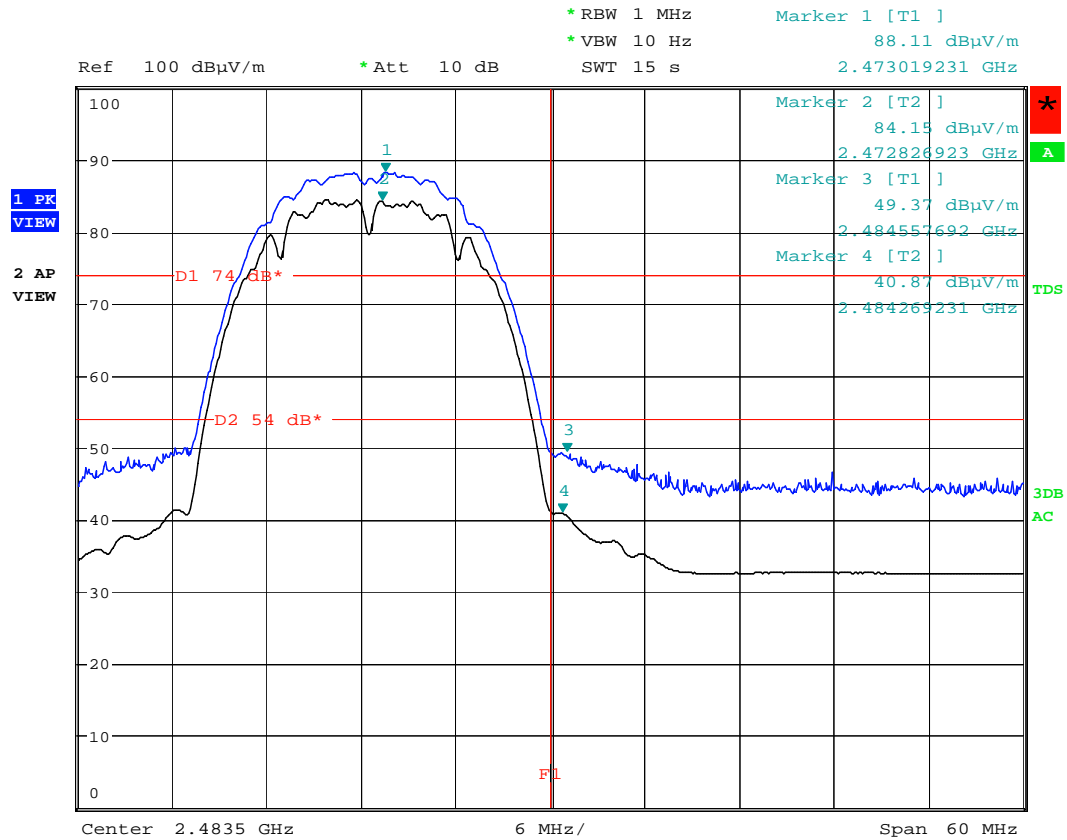

Band Edge, Mode b3  
 Date: 13.SEP.2010 10:51:13

Note: The upper trace shows the peak value and the lower trace shows the average value.



Produkte  
 Products

Prüfbericht - Nr.: **12606802 007**  
 Test Report No.:

Seite 25 von 42  
 Page 25 of 42

**Table 11: Band Edge Radiated Emission, 802.11g**

Operating Frequency [MHz]	EUT / Antenna Orient.	Average Value [dBuV/m]	Peak Value [dBuV/m]	Average Limit [dBuV/m]	Peak Limit [dBuV/m]	Average Margin [dB]	Peak Margin [dB]
2412	Y/V	36.63	54.15	54.00	74.00	17.37	19.85
2472	X/H	43.89	71.98	54.00	74.00	10.11	2.02*

Notes: All correction factors (antenna, cable, pre-amplifier) are included in the measurement values.  
 Average limit in dBuV/m is calculated as follows: Average limit = 20 x log(500uV/m).  
 Peak limit in dBuV/m is calculated as follows: Peak limit = Average limit + 20dB.

**Figure 4: Band Edge Radiated Emission, Mode g1 (2412MHz), Peak and Average**

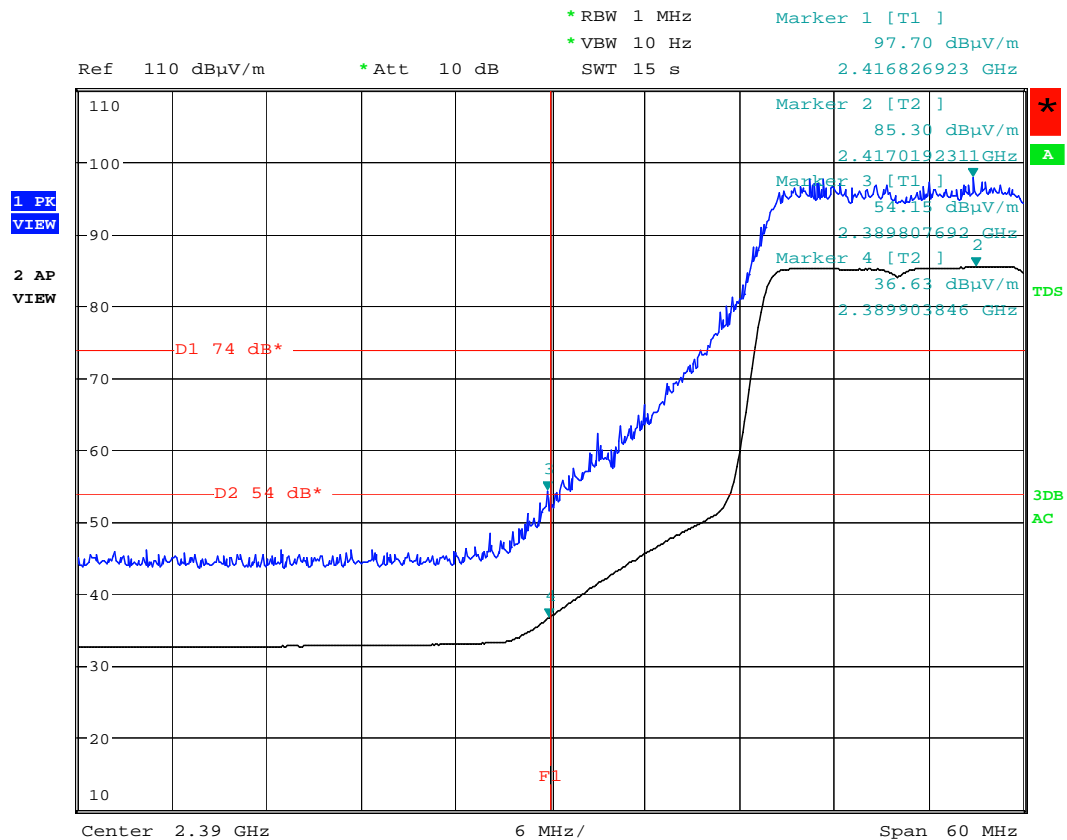

Band Edge, Mode g1  
 Date: 13.SEP.2010 11:16:18

Note: The upper trace shows the peak value and the lower trace shows the average value.

Produkte  
 Products

Prüfbericht - Nr.: 12606802 007  
 Test Report No.:

Seite 26 von 42  
 Page 26 of 42

Figure 5: Band Edge Radiated Emission, Mode g3 (2472MHz), Peak and Average

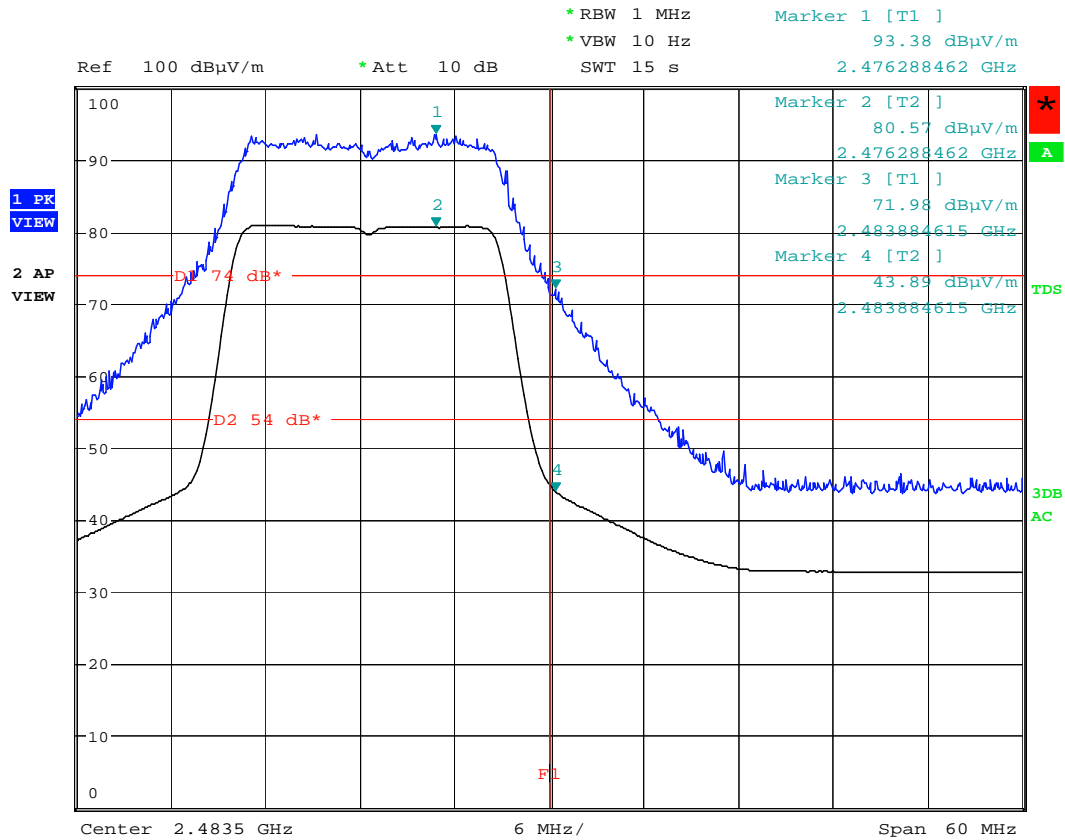

Band Edge, Mode g3

Date: 13.SEP.2010 10:37:20

Note: The upper trace shows the peak value and the lower trace shows the average value.

Uncertainty

(\*) The measured result is below the specification limit by a margin less than the measurement uncertainty; it is not therefore possible to determine compliance at a level of confidence of 95%. However, the measured result indicates a higher probability that the product tested complies with the specification limit.

Produkte  
Products

**Prüfbericht - Nr.: 12606802 007**

Seite 27 von 42

Test Report No.:

Page 27 of 42

**6.1.2 Radiated Emission, Out-of-Band and Spurious Emission, FCC 15.247(d), FCC 15.205, FCC 15.209, RSS-210 2.2, RSS-210 A8.5 and RSS-Gen 7.2.1**

**RESULT: PASS**

Date of testing:	2010-09-13	2010-09-14	2010-09-15
Ambient temperature:	22°C	23°C	22°C
Relative humidity:	67%	67%	72%
Atmospheric pressure:	1000hPa	1005hPa	1013hPa
Frequency range:	9kHz – 25GHz		
Measurement distance:	3m		
Kind of test site:	Semi Anechoic Chamber		

**Requirements:**

The emissions from the intentional radiator shall not exceed the field strength specified in FCC 15.209(a) and RSS-210 2.7.

**Test procedure:**

ANSI C63.4-2003, RSS-Gen 4.9, 4.10 and Measurement of Digital Transmission Systems Operating under Section 15.247

Before final measurements of radiated emissions were made in Semi Anechoic Chamber, the EUT was scanned to determine its emission spectrum profile. The physical arrangement of the test system, the associated cabling and the host orientation (X, Y and Z) were varied in order to ensure that maximum emission amplitudes were attained. Y orientation below 1GHz and X orientation above 1GHz with the movable antenna (nearly right angle) were found to conduct the final measurement.

The EUT was placed on a nonconductive turntable 0.8m above the ground plane. Final radiated emission measurements were made at 3m. The spectrum was examined from 30 MHz to the 10th harmonic of the highest fundamental transmitter frequency (25 GHz).

At each frequency, the EUT was rotated 360°, and the antenna was raised and lowered from 1 to 4 meters in order to determine the emission's maximum level. Measurements were taken using both horizontal and vertical antenna polarizations.

For frequencies between 30MHz and 1GHz, the spectrum analyzer's 6 dB bandwidth was set to 120 kHz, and the analyzer was operated in the CISPR quasi-peak detection mode. For emissions above 1GHz, emissions were measured using following settings: Peak: RBW=1MHz, VBW=1MHz, Average: RBW=1MHz, VBW=10Hz.

The highest emission amplitudes relative to the appropriate limit were recorded in this report. Emissions other than those mentioned are small or not detectable.

Produkte  
 Products

**Prüfbericht - Nr.: 12606802 007**  
 Test Report No.:

**Seite 28 von 42**  
 Page 28 of 42

**Table 12: Radiated Emission 30MHz – 1GHz, Horizontal & Vertical Antenna Orientations, Quasi Peak Data, Mode b1, 802.11b**

Freq. [MHz]	Antenna polarity	Reading QP [dB(µV)]	Factor [dB(1/m)]	Level QP [dB(µV/m)]	Limit [dB(µV/m)]	Margin QP [dB]	Height [cm]	Angle [°]
201.09	H	46.4	-25.3	21.1	43.5	22.4	178	95
268.12	H	48.9	-22.1	26.8	46.0	19.2	100	30
402.18	H	50.6	-18.1	32.5	46.0	13.5	255	39
938.40	H	40.4	-9.4	31.0	46.0	15.0	150	234
44.68	V	44.7	-23.3	21.4	40.0	18.6	100	169
402.15	V	48.8	-17.3	31.5	46.0	14.5	132	164
804.37	V	38.5	-11.0	27.5	46.0	18.5	141	160
871.35	V	41.0	-10.6	30.4	46.0	15.6	133	126
938.40	V	43.8	-9.7	34.1	46.0	11.9	113	268

Note: Level QP = Reading QP + Factor

**Table 13: Radiated Emission 1GHz – 25GHz, Horizontal & Vertical Antenna Orientations, Peak and Average Data, Mode b1, 802.11b**

Freq. [MHz]	Antenna polarity	Reading AV [dB(µV)]	Reading PK [dB(µV)]	Factor [dB(1/m)]	Level AV [dB(µV/m)]	Level PK [dB(µV/m)]	Limit AV / PK [dB(µV/m)]	Margin AV [dB]	Margin PK [dB]	Height [cm]	Angle [°]
1742.683	H	45.4	53.2	-13.3	32.1	39.9	54.0 / 74.0	21.9	34.1	138	304
2884.232	H	38.2	51.9	-11.6	26.6	40.3	54.0 / 74.0	27.4	33.7	179	88
7324.842	H	38.2	52.6	-4.6	33.6	48.0	54.0 / 74.0	20.4	26.0	112	351
1139.474	V	47.0	59.4	-15.7	31.3	43.7	54.0 / 74.0	22.7	30.3	101	267
1206.490	V	52.8	57.5	-15.1	37.7	42.4	54.0 / 74.0	16.3	31.6	101	308
1742.732	V	51.5	56.3	-13.3	38.2	43.0	54.0 / 74.0	15.8	31.0	107	85

Note: All correction factors (antenna, cable, pre-amplifier) are included in the measurement values.

Produkte  
 Products

**Prüfbericht - Nr.: 12606802 007**

Seite 29 von 42  
 Page 29 of 42

Test Report No.:

**Table 14: Radiated Emission 30MHz – 1GHz, Horizontal & Vertical Antenna Orientations, Quasi Peak Data, Mode b2, 802.11b**

Freq. [MHz]	Antenna polarity	Reading QP [dB(µV)]	Factor [dB(1/m)]	Level QP [dB(µV/m)]	Limit [dB(µV/m)]	Margin QP [dB]	Height [cm]	Angle [°]
268.11	H	49.0	-22.1	26.9	46.0	19.1	102	31
402.15	H	48.6	-18.1	30.5	46.0	15.5	101	33
938.42	H	39.7	-9.4	30.3	46.0	15.7	149	237
44.66	V	44.8	-23.3	21.5	40.0	18.5	101	182
402.17	V	50.1	-17.3	32.8	46.0	13.2	141	186
804.35	V	39.4	-11.0	28.4	46.0	17.6	130	172
871.40	V	39.1	-10.6	28.5	46.0	17.5	133	112
938.39	V	43.5	-9.7	33.8	46.0	12.2	113	262

Note: Level QP = Reading QP + Factor

**Table 15: Radiated Emission 1GHz – 25GHz, Horizontal & Vertical Antenna Orientations, Peak and Average Data, Mode b2, 802.11b**

Freq. [MHz]	Antenna polarity	Reading AV [dB(µV)]	Reading PK [dB(µV)]	Factor [dB(1/m)]	Level AV [dB(µV/m)]	Level PK [dB(µV/m)]	Limit AV / PK [dB(µV/m)]	Margin AV [dB]	Margin PK [dB]	Height [cm]	Angle [°]
1474.587	H	44.9	53.3	-14.6	30.3	38.7	54.0 / 74.0	23.7	35.3	103	337
1742.713	H	42.4	53.1	-13.3	29.1	39.8	54.0 / 74.0	24.9	34.2	102	171
7294.343	H	38.3	52.3	-4.6	33.7	47.7	54.0 / 74.0	20.3	26.3	180	185
1139.432	V	46.3	59.0	-15.7	30.6	43.3	54.0 / 74.0	23.4	30.7	100	273
1206.505	V	52.5	57.1	-15.1	37.4	42.0	54.0 / 74.0	16.6	32.0	100	259
1742.725	V	51.4	56.5	-13.3	38.1	43.2	54.0 / 74.0	15.9	30.8	100	88

Note: All correction factors (antenna, cable, pre-amplifier) are included in the measurement values.

Produkte  
 Products

**Prüfbericht - Nr.: 12606802 007**

Seite 30 von 42

Test Report No.:

Page 30 of 42

**Table 16: Radiated Emission 30MHz – 1GHz, Horizontal & Vertical Antenna Orientations, Quasi Peak Data, Mode b3, 802.11b**

Freq. [MHz]	Antenna polarity	Reading QP [dB(µV)]	Factor [dB(1/m)]	Level QP [dB(µV/m)]	Limit [dB(µV/m)]	Margin QP [dB]	Height [cm]	Angle [°]
268.11	H	49.0	-22.1	26.9	46.0	19.1	100	34
402.19	H	50.1	-18.1	32.0	46.0	14.0	243	40
938.39	H	38.2	-9.4	28.8	46.0	17.2	170	75
44.69	V	45.1	-23.3	21.8	40.0	18.2	104	151
402.18	V	49.0	-17.3	31.7	46.0	14.3	126	166
804.36	V	39.2	-11.0	28.2	46.0	17.8	138	167
871.37	V	41.5	-10.6	30.9	46.0	15.1	128	112
938.41	V	43.0	-9.7	33.3	46.0	12.7	115	272

Note: Level QP = Reading QP + Factor

**Table 17: Radiated Emission 1GHz – 25GHz, Horizontal & Vertical Antenna Orientations, Peak and Average Data, Mode b3, 802.11b**

Freq. [MHz]	Antenna polarity	Reading AV [dB(µV)]	Reading PK [dB(µV)]	Factor [dB(1/m)]	Level AV [dB(µV/m)]	Level PK [dB(µV/m)]	Limit AV / PK [dB(µV/m)]	Margin AV [dB]	Margin PK [dB]	Height [cm]	Angle [°]
1474.605	H	45.1	53.9	-14.6	30.5	39.3	54.0 / 74.0	23.5	34.7	145	339
7375.201	H	37.8	52.2	-4.6	33.2	47.6	54.0 / 74.0	20.8	26.4	101	213
1161.749	V	38.5	56.7	-15.5	23.0	41.2	54.0 / 74.0	31.0	32.8	167	313
1206.496	V	52.5	57.3	-15.1	37.4	42.2	54.0 / 74.0	16.6	31.8	101	321
1742.704	V	52.0	57.3	-13.3	38.7	44.0	54.0 / 74.0	15.3	30.0	102	67
4540.799	V	38.4	52.5	-9.5	28.9	43.0	54.0 / 74.0	25.1	31.0	137	250

Note: All correction factors (antenna, cable, pre-amplifier) are included in the measurement values.

Produkte  
 Products

**Prüfbericht - Nr.: 12606802 007**

**Seite 31 von 42**

Test Report No.:

Page 31 of 42

**Table 18: Radiated Emission 30MHz – 1GHz, Horizontal & Vertical Antenna Orientations, Quasi Peak Data, Mode g1, 802.11g**

Freq. [MHz]	Antenna polarity	Reading QP [dB(μV)]	Factor [dB(1/m)]	Level QP [dB(μV/m)]	Limit [dB(μV/m)]	Margin QP [dB]	Height [cm]	Angle [°]
32.050	H	45.4	-24.3	21.1	40.0	18.9	100	359
268.095	H	48.8	-22.1	26.7	46.0	19.3	101	29
402.158	H	49.0	-18.1	30.9	46.0	15.1	246	199
32.050	V	47.1	-24.6	22.5	40.0	17.5	100	1
44.690	V	45.7	-23.3	22.4	40.0	17.6	100	196
402.157	V	51.4	-17.3	34.1	46.0	11.9	145	168
871.360	V	41.6	-10.6	31.0	46.0	15.0	137	123
938.386	V	43.0	-9.7	33.3	46.0	12.7	112	259

Note: Level QP = Reading QP + Factor

**Table 19: Radiated Emission 1GHz – 25GHz, Horizontal & Vertical Antenna Orientations, Peak and Average Data, Mode g1, 802.11g**

Freq. [MHz]	Antenna polarity	Reading AV [dB(μV)]	Reading PK [dB(μV)]	Factor [dB(1/m)]	Level AV [dB(μV/m)]	Level PK [dB(μV/m)]	Limit AV / PK [dB(μV/m)]	Margin AV [dB]	Margin PK [dB]	Height [cm]	Angle [°]
1742.725	H	48.2	54.7	-13.3	34.9	41.4	54.0 / 74.0	19.1	32.6	135	311
3552.492	H	38.0	52.2	-10.0	28.0	42.1	54.0 / 74.0	26.0	31.9	100	183
1139.456	V	45.9	59.3	-15.7	30.2	43.6	54.0 / 74.0	23.8	30.4	100	270
1206.500	V	53.0	57.5	-15.1	37.9	42.4	54.0 / 74.0	16.1	31.6	100	312
1742.724	V	52.0	57.3	-13.3	38.7	44.0	54.0 / 74.0	15.3	30.0	100	83
5541.053	V	38.5	52.4	-7.6	30.9	44.8	54.0 / 74.0	23.1	29.2	193	175

Note: All correction factors (antenna, cable, pre-amplifier) are included in the measurement values.

Produkte  
 Products

**Prüfbericht - Nr.: 12606802 007**

Seite 32 von 42  
 Page 32 of 42

Test Report No.:

**Table 20: Radiated Emission 30MHz – 1GHz, Horizontal & Vertical Antenna Orientations, Quasi Peak Data, Mode g2, 802.11g**

Freq. [MHz]	Antenna polarity	Reading QP [dB(µV)]	Factor [dB(1/m)]	Level QP [dB(µV/m)]	Limit [dB(µV/m)]	Margin QP [dB]	Height [cm]	Angle [°]
32.054	H	45.3	-24.3	21.0	40.0	19.0	100	359
268.097	H	49.0	-22.1	26.9	46.0	19.1	100	31
402.172	H	49.0	-18.1	30.9	46.0	15.1	101	45
32.048	V	47.4	-24.6	22.8	40.0	17.2	100	1
44.696	V	45.0	-23.3	21.7	40.0	18.3	100	189
49.980	V	38.8	-23.2	15.6	40.0	24.4	100	203
402.168	V	51.8	-17.3	34.5	46.0	11.5	130	170
871.376	V	41.6	-10.6	31.0	46.0	15.0	131	148
938.397	V	43.1	-9.7	33.4	46.0	12.6	112	260

Note: Level QP = Reading QP + Factor

**Table 21: Radiated Emission 1GHz – 25GHz, Horizontal & Vertical Antenna Orientations, Peak and Average Data, Mode g2, 802.11g**

Freq. [MHz]	Antenna polarity	Reading AV [dB(µV)]	Reading PK [dB(µV)]	Factor [dB(1/m)]	Level AV [dB(µV/m)]	Level PK [dB(µV/m)]	Limit AV / PK [dB(µV/m)]	Margin AV [dB]	Margin PK [dB]	Height [cm]	Angle [°]
1474.601	H	45.0	54.1	-14.6	30.4	39.5	54.0 / 74.0	23.6	34.5	100	338
4527.056	H	38.6	52.8	-9.5	29.1	43.3	54.0 / 74.0	24.9	30.7	114	155
1139.463	V	46.5	59.0	-15.7	30.8	43.3	54.0 / 74.0	23.2	30.7	100	258
1206.482	V	52.9	57.3	-15.1	37.8	42.2	54.0 / 74.0	16.2	31.8	100	317
1742.700	V	51.2	56.6	-13.3	37.9	43.3	54.0 / 74.0	16.1	30.7	107	77
5901.804	V	38.3	52.6	-7.8	30.5	44.8	54.0 / 74.0	23.5	29.2	123	18

Note: All correction factors (antenna, cable, pre-amplifier) are included in the measurement values.



Produkte  
 Products

**Prüfbericht - Nr.: 12606802 007**

Seite 33 von 42

Test Report No.:

Page 33 of 42

**Table 22: Radiated Emission 30MHz – 1GHz, Horizontal & Vertical Antenna Orientations, Quasi Peak Data, Mode g3, 802.11g**

Freq. [MHz]	Antenna polarity	Reading QP [dB(µV)]	Factor [dB(1/m)]	Level QP [dB(µV/m)]	Limit [dB(µV/m)]	Margin QP [dB]	Height [cm]	Angle [°]
32.050	H	46.9	-24.3	22.6	40.0	17.4	400	1
34.971	H	36.9	-24.1	12.8	40.0	27.2	100	225
268.087	H	49.1	-22.1	27.0	46.0	19.0	112	101
335.148	H	43.5	-19.8	23.7	46.0	22.3	100	101
402.148	H	47.9	-18.1	29.8	46.0	16.2	220	103
938.388	H	40.9	-9.4	31.5	46.0	14.5	150	261
32.059	V	44.3	-24.6	19.7	40.0	20.3	100	359
44.683	V	45.6	-23.3	22.3	40.0	17.7	102	170
48.519	V	39.6	-23.2	16.4	40.0	23.6	100	204
402.178	V	51.7	-17.3	34.4	46.0	11.6	139	76
871.369	V	42.3	-10.6	31.7	46.0	14.3	126	192
938.402	V	43.2	-9.7	33.5	46.0	12.5	113	325

Note: Level QP = Reading QP + Factor

**Table 23: Radiated Emission 1GHz – 25GHz, Horizontal & Vertical Antenna Orientations, Peak and Average Data, Mode g3, 802.11g**

Freq. [MHz]	Antenna polarity	Reading AV [dB(µV)]	Reading PK [dB(µV)]	Factor [dB(1/m)]	Level AV [dB(µV/m)]	Level PK [dB(µV/m)]	Limit AV / PK [dB(µV/m)]	Margin AV [dB]	Margin PK [dB]	Height [cm]	Angle [°]
3574.781	H	38.2	53.1	-9.9	28.3	43.2	54.0 / 74.0	25.7	30.8	174	199
4900.222	H	38.3	52.4	-9.1	29.2	43.3	54.0 / 74.0	24.8	30.7	185	219
7397.726	H	37.9	51.8	-4.6	33.3	47.2	54.0 / 74.0	20.7	26.8	105	134
1139.517	V	46.1	58.4	-15.7	30.4	42.7	54.0 / 74.0	23.6	31.3	104	264
1206.499	V	52.9	57.6	-15.1	37.8	42.5	54.0 / 74.0	16.2	31.5	100	300
1742.728	V	51.9	57.1	-13.3	38.6	43.8	54.0 / 74.0	15.4	30.2	107	63

Note: All correction factors (antenna, cable, pre-amplifier) are included in the measurement values.

## 6.2 Radiated Emission of Receiver

### 6.2.1 Radiated Emission of Receiver, FCC 15.109, RSS-210 2.2, RSS-210 2.6, RSS-210 A8.5, RSS-Gen 7.2.3.2

**RESULT:**

**PASS**

Date of testing:	2010-09-13	2010-09-14	2010-09-15
Ambient temperature:	22°C	23°C	22°C
Relative humidity:	67%	67%	72%
Atmospheric pressure:	1000hPa	1005hPa	1013hPa
Frequency range:	30MHz – 12.5GHz		
Equipment classification:	Class B		
Measurement distance:	3m		
Kind of test site:	Semi Anechoic Chamber		

**Requirements:**

The emissions from the unintentional radiator shall not exceed the field strength specified in 15.109(a) and RSS-210 Table 2 (and RSS-Gen Table 1).

**Test procedure:**

ANSI C63.4-2003, RSS-Gen 4.9, 4.10

Before final measurements of radiated emissions were made in Semi Anechoic Chamber, the EUT was scanned to determine its emission spectrum profile. The physical arrangement of the test system, the associated cabling and the orientation (X, Y & Z) of the EUT and movable antenna were varied in order to ensure that maximum emission amplitudes were attained. Y orientation below 1GHz and X orientation above 1GHz with the movable antenna (nearly right angle) were found to conduct the final measurement.

The EUT was placed on a nonconductive turntable 0.8m above the ground plane. Final radiated emission measurements were made at 3m. The spectrum was examined from 30 MHz to the 5th harmonic of the highest fundamental transmitter frequency (12.5 GHz).

At each frequency, the EUT was rotated 360°, and the antenna was raised and lowered from 1 to 4 meters in order to determine the emission's maximum level. Measurements were taken using both horizontal and vertical antenna polarizations.

For frequencies between 30MHz and 1GHz, the spectrum analyzer's 6 dB bandwidth was set to 120 kHz, and the analyzer was operated in the CISPR quasi-peak detection mode. For emissions above 1GHz, emissions were measured using following settings: Peak: RBW=1MHz, VBW=1MHz, Average: RBW=1MHz, VBW=10Hz.

Produkte  
 Products

**Prüfbericht - Nr.: 12606802 007**

Seite 35 von 42

Test Report No.:

Page 35 of 42

The highest emission amplitudes relative to the appropriate limit were recorded in this report. Emissions other than those mentioned are small or not detectable.

**Table 24: Radiated Emission 30MHz – 1GHz, Horizontal & Vertical Antenna Orientations, Quasi Peak Data, Mode R, 802.11b/g**

Freq. [MHz]	Antenna polarity	Reading QP [dB(µV)]	Factor [dB(1/m)]	Level QP [dB(µV/m)]	Limit [dB(µV/m)]	Margin QP [dB]	Height [cm]	Angle [°]
268.107	H	48.1	-22.1	26.0	46.0	20.0	100	192
402.182	H	52.2	-18.1	34.1	46.0	11.9	100	223
938.382	H	38.5	-9.4	29.1	46.0	16.9	101	149
402.165	V	47.7	-17.3	30.4	46.0	15.6	163	144
670.294	V	38.9	-12.3	26.6	46.0	19.4	100	231
804.315	V	38.6	-11.0	27.6	46.0	18.4	147	165
871.388	V	40.0	-10.6	29.4	46.0	16.6	140	149
938.389	V	42.6	-9.7	32.9	46.0	13.1	124	249

Note: Level QP = Reading QP + Factor

**Table 25: Radiated Emission 1GHz – 12.5GHz, Horizontal & Vertical Antenna Orientations, Peak and Average Data, Mode R, 802.11b/g**

Freq. [MHz]	Antenna polarity	Reading AV [dB(µV)]	Reading PK [dB(µV)]	Factor [dB(1/m)]	Level AV [dB(µV/m)]	Level PK [dB(µV/m)]	Limit AV / PK [dB(µV/m)]	Margin AV [dB]	Margin PK [dB]	Height [cm]	Angle [°]
1137.672	H	38.4	53.7	-15.7	22.7	37.9	54.0 / 74.0	31.3	36.1	193	9
1206.489	H	48.8	55.6	-15.1	33.7	40.5	54.0 / 74.0	20.3	33.5	163	55
2259.102	H	37.4	51.4	-13.1	24.3	38.3	54.0 / 74.0	29.7	35.7	119	106
3532.822	H	37.6	52.2	-10.2	27.4	42.0	54.0 / 74.0	26.6	32.0	164	75
1206.496	V	51.4	56.6	-15.1	36.3	41.5	54.0 / 74.0	17.7	32.5	106	246
1742.722	V	50.7	56.5	-13.3	37.4	43.2	54.0 / 74.0	16.6	30.8	107	187

Note: All correction factors (antenna, cable, pre-amplifier) are included in the measurement values.

## 8. List of Tables

Table 1: List of Test and Measurement Equipment .....	8
Table 2: Emission Measurement Uncertainty .....	9
Table 3: Interfaces present on the EUT .....	11
Table 4: The Date rate corresponds the worst case of each frequency band of different radio .....	12
Table 5: Conducted Emission, 150kHz – 30MHz, Quasi Peak and Average Data, Phase N (N) and L1 (L), Mode b1, 802.11b .....	18
Table 6: Conducted Emission, 150kHz – 30MHz, Quasi Peak and Average Data, Phase N (N) and L1 (L), Mode b3, 802.11b .....	18
Table 7: Conducted Emission, 150kHz – 30MHz, Quasi Peak and Average Data, Phase N (N) and L1 (L), Mode g1, 802.11g .....	19
Table 8: Conducted Emission, 150kHz – 30MHz, Quasi Peak and Average Data, Phase N (N) and L1 (L), Mode g3, 802.11g .....	19
Table 9: Conducted Emission, 150kHz – 30MHz, Quasi Peak and Average Data, Phase N (N) and L1 (L), Mode R, 802.11b/g .....	21
Table 10: Band Edge Radiated Emission, 802.11b .....	23
Table 11: Band Edge Radiated Emission, 802.11g .....	25
Table 12: Radiated Emission 30MHz – 1GHz, Horizontal & Vertical Antenna Orientations, Quasi Peak Data, Mode b1, 802.11b .....	28
Table 13: Radiated Emission 1GHz – 25GHz, Horizontal & Vertical Antenna Orientations, Peak and Average Data, Mode b1, 802.11b .....	28
Table 14: Radiated Emission 30MHz – 1GHz, Horizontal & Vertical Antenna Orientations, Quasi Peak Data, Mode b2, 802.11b .....	29
Table 15: Radiated Emission 1GHz – 25GHz, Horizontal & Vertical Antenna Orientations, Peak and Average Data, Mode b2, 802.11b .....	29
Table 16: Radiated Emission 30MHz – 1GHz, Horizontal & Vertical Antenna Orientations, Quasi Peak Data, Mode b3, 802.11b .....	30
Table 17: Radiated Emission 1GHz – 25GHz, Horizontal & Vertical Antenna Orientations, Peak and Average Data, Mode b3, 802.11b .....	30
Table 18: Radiated Emission 30MHz – 1GHz, Horizontal & Vertical Antenna Orientations, Quasi Peak Data, Mode g1, 802.11g .....	31
Table 19: Radiated Emission 1GHz – 25GHz, Horizontal & Vertical Antenna Orientations, Peak and Average Data, Mode g1, 802.11g .....	31
Table 20: Radiated Emission 30MHz – 1GHz, Horizontal & Vertical Antenna Orientations, Quasi Peak Data, Mode g2, 802.11g .....	32
Table 21: Radiated Emission 1GHz – 25GHz, Horizontal & Vertical Antenna Orientations, Peak and Average Data, Mode g2, 802.11g .....	32
Table 22: Radiated Emission 30MHz – 1GHz, Horizontal & Vertical Antenna Orientations, Quasi Peak Data, Mode g3, 802.11g .....	33
Table 23: Radiated Emission 1GHz – 25GHz, Horizontal & Vertical Antenna Orientations, Peak and Average Data, Mode g3, 802.11g .....	33
Table 24: Radiated Emission 30MHz – 1GHz, Horizontal & Vertical Antenna Orientations, Quasi Peak Data, Mode R, 802.11b/g .....	35
Table 25: Radiated Emission 1GHz – 12.5GHz, Horizontal & Vertical Antenna Orientations, Peak and Average Data, Mode R, 802.11b/g .....	35

## 9. List of Figures

Figure 1: Test setup .....	15
Figure 2: Band Edge Radiated Emission, Mode b1 (2412MHz), Peak and Average .....	23
Figure 3: Band Edge Radiated Emission, Mode b3 (2472MHz), Peak and Average .....	24

**Produkte**  
Products

**Prüfbericht - Nr.: 12606802 007**  
Test Report No.:

**Seite 42 von 42**  
Page 42 of 42

Figure 4: Band Edge Radiated Emission, Mode g1 (2412MHz), Peak and Average .....25  
Figure 5: Band Edge Radiated Emission, Mode g3 (2472MHz), Peak and Average .....26

## 10. List of Photographs

Photograph 1: Set-up for AC Mains Conducted Emission of Transmitter and Receiver, Front View .....36  
Photograph 2: Set-up for AC Mains Conducted Emission of Transmitter and Receiver, Rear View.....37  
Photograph 3: Set-up for Radiated Emission, EUT Configuration X-Axis (Movable antenna) .....37  
Photograph 4: Set-up for Radiated Emission, EUT Configuration Y-Axis (Movable antenna) .....38  
Photograph 5: Set-up for Radiated Emission, EUT Configuration Z-Axis (Movable antenna) .....38  
Photograph 6: Set-up for Radiated Emission of Transmitter, Front View .....39  
Photograph 7: Set-up for Radiated Emission of Transmitter, Rear View.....39  
Photograph 8: Set-up for Radiated Emission of Receiver, Front View .....40  
Photograph 9: Set-up for Radiated Emission of Receiver, Rear View.....40