

Engineering and Testing for EMC and Safety Compliance

APPLICATION FOR FCC CERTIFICATION

CLASS B DIGITAL DEVICE

Korea Data Systems Co., Ltd.
170 Gongdan-Don, Gumi-Si
Gyungbuk 730-030 Korea

MODEL: KD-1731 17" Monitor

FCC ID: EVOKD-1731

July 10, 1998

This report concerns (check one): Equipment Type: Monitor	Original Grant: X	Class II Change:
Deferred grant requested per 47 CFR 0.457 (d) (1) (ii)? If yes, defer until: _____	Yes:	No: X Date
Company name agrees to notify the Commission by: _____ (date) of the intended date of announcement of the product so that the grant can be issued on that date.		
Transition Rules Request per 15.37? Yes: No: X If no, assumed Part 15, subpart B for unintentional radiators - the new 47 CFR [10-1-90 Edition] provision.		

REPORT PREPARED BY:

EMI Technician: Robert Thomson
Administrative Writer: Linda Harrison

Rhein Tech Laboratories, Inc.

Document Number: 980370

No part of this report may be reproduced without the full written approval of Rhein Tech Laboratories, Inc.

360 Herndon Parkway, Suite 1400
Herndon, VA 20170
703 689-0368 FAX 703 689-2056 METRO 703 471-6441

TABLE OF CONTENTS

1.0 GENERAL INFORMATION	1
1.1 PRODUCT DESCRIPTION	1
1.2 RELATED SUBMITTAL(S)/GRANT(S)	1
1.3 TESTED SYSTEM DETAILS	2
1.4 CONFIGURATION OF TESTED SYSTEM	3
1.5 TEST METHODOLOGY	4
1.6 TEST FACILITY	4
2.0 PRODUCT LABELING	5
3.0 SYSTEM TEST CONFIGURATION.....	6
3.1 JUSTIFICATION	6
3.2 EUT EXERCISE SOFTWARE	6
3.3 SPECIAL ACCESSORIES	6
3.4 CONFORMANCE STATEMENT	7
4.0 MEASUREMENT PHOTOS.....	8
4.1 CONDUCTED MEASUREMENT PHOTOS	8
4.2 RADIATED MEASUREMENT PHOTOS	9
5.0 BLOCK DIAGRAM OF KD-1731 17" MONITOR.....	10
6.0 CONDUCTED EMISSION DATA.....	11
7.0 RADIATED EMISSION DATA	13
7.1 FIELD STRENGTH CALCULATION	15
8.0 PHOTOS OF TESTED EUT	16

APPENDIX LISTING

APPENDIX A: EMISSIONS EQUIPMENT LIST	17
APPENDIX B: CONDUCTED AND RADIATED TEST METHODOLOGY	18
APPENDIX C: USER'S MANUAL	19

FIGURE INDEX

FIGURE 1:	FCC ID LABEL.....	5
FIGURE 2:	LOCATION OF LABEL ON EUT.....	5
FIGURE 3:	MONITOR FRONT.....	16
FIGURE 4:	BACK OF MONITOR, SHOWING LABEL.....	16
FIGURE 5:	LEFT SIDE OF MONITOR.....	16
FIGURE 6:	RIGHT SIDE OF MONITOR.....	16
FIGURE 7:	BOTTOM OF MONITOR.....	16
FIGURE 8:	COVER INTERIOR OF MONITOR.....	16
FIGURE 9:	BEZEL INTERIOR.....	16
FIGURE 10:	TOP OF MONITOR, COVER REMOVED.....	16
FIGURE 11:	BOTTOM MONITOR, COVER REMOVED.....	16
FIGURE 12:	LEFT SIDE OF MONITOR, COVER REMOVED.....	16
FIGURE 13:	RIGHT SIDE OF MONITOR, COVER REMOVED.....	16
FIGURE 14:	BACK OF MONITOR, COVER REMOVED, CRT NECK BOARD WITH SHIELDED, SOLDER SIDE.....	16
FIGURE 15:	BACK SIDE OF CRT TUBE.....	16
FIGURE 16:	MAIN BOARD, COMPONENT SIDE.....	16
FIGURE 17:	MAIN BOARD, SOLDER SIDE.....	16
FIGURE 18:	CRT NECK, COMPONENT SIDE.....	16
FIGURE 19:	CRT NECK, SOLDER SIDE.....	16

TABLE INDEX

TABLE 1:	TESTED SYSTEM DETAILS.....	2
TABLE 2:	CONDUCTED EMISSIONS 1024 x 768 @ 85 Hz.....	10
TABLE 3:	CONDUCTED EMISSIONS 1280 x 1024 @ 60 Hz.....	11
TABLE 4:	RADIATED EMISSIONS 1024 x 768 @ 85 Hz.....	12
TABLE 5:	RADIATED EMISSIONS 1280 x 1024 @ 60 Hz.....	13
TABLE 6:	EMISSIONS EQUIPMENT LIST.....	17

1.0 GENERAL INFORMATION

The following application for FCC Certification of a Class B Digital Device is prepared on behalf of Korea Data Systems, Co. Ltd. in accordance with Part 2, and Part 15, Subparts A and B of the Federal Communications Commissions rules and regulations. The Equipment Under Test (EUT) was the Korea Data Systems, Co. Ltd., KD-1731 17" Monitor, FCC ID: EVOKD-1731. The test results reported in this document relate only to the item that was tested.

All measurements contained in this application were conducted in accordance with ANSI C63.4 Methods of Measurement of Radio Noise Emissions, 1992. The instrumentation utilized for the measurements conforms with the ANSI C63.4 standard for EMI and Field Strength Instrumentation. Some accessories are used to increase sensitivity and prevent overloading of the measuring instruments. These are explained in the appendix of this report. Calibration checks are performed regularly on the instruments, and all accessories including the high pass filter, preamplifier and cables.

All radiated and conducted emission measurements were performed manually at Rhein Tech Laboratories, Inc. The radiated emission measurements required by the rules were performed on the ten meter, open field, test range maintained by Rhein Tech Laboratories, Inc., 360 Herndon Parkway, Suite 1400, Herndon, Virginia 20170. Complete description and site attenuation measurement data have been placed on file with the Federal Communications Commission. The power line conducted emission measurements were performed in a shielded enclosure also located at the Herndon, Virginia facility. Rhein Tech Laboratories is accepted by the FCC as a facility available to do measurement work for others on a contract basis.

1.1 PRODUCT DESCRIPTION

Features:

17" antiglare, flat screen, high-contrast picture tube.
 0.28mm dot pitch
 IBM compatible
 Multi-scan: horizontal frequencies 30-70kHz, vertical frequencies 50-150Hz.
 Universal auto-switching power supply.
 Power management
 Digital controls for sizing and distortion
 DDC 2B

DDC STATEMENTS

New DDC compatibility simplifies the installation and set-up process for users. By accessing the Plug & Play features of Windows®95 operation software, the monitor automatically senses the optimal set-up specifications available on the host system. The monitor is configured with minimal need for interaction or expertise on the part of the user.

1.2 RELATED SUBMITTAL(S)/GRANT(S)

N/A. This is an original submittal.

1.3 TESTED SYSTEM DETAILS

The FCC Identifiers for all equipment, plus descriptions of all cables used in the tested system (including inserted cards, which have grants) are:

TABLE 1: TESTED SYSTEM DETAILS

EXTERNAL COMPONENTS

DESCRIPTION	MANUFACTURER	MODEL	SERIAL NO	FCC ID	CABLE DESCRIPTIONS	RTL BAR CODE
KEYBOARD	MAXI SWITCH, INC.	2196003-14-111	50432723	D7J2196003-XX	SHIELDED I/O	8441
MODEM	US ROBOTICS	0413	839032B26M4PN	DoC	SHIELDED I/O; UNSHIELDED POWER	900407
MONITOR	KOREA DATA SYSTEMS, Co., LTD. (EUT)	KD-1731	N/A	EVOKD-1731	SHIELDED I/O, FERRITE ON COMPUTER END; UNSHIELDED POWER	9459
MOUSE	MICROSOFT CORPORATION	2.1A	01309322	C3KKMP1	SHIELDED I/O	8551
PRINTER	HEWLETT PACKARD	2225C	2804S03388	DSI6XU2225	SHIELDED I/O; UNSHIELDED POWER	900135
SYSTEM	GATEWAY 2000, INC.	LOW PROFILE MINI-TOWER	0007375884	DoC	SHIELDED POWER	900578

INTERNAL COMPONENTS

DESCRIPTION	MANUFACTURER	MODEL	SERIAL NO	FCC ID	CABLE DESCRIPTIONS	RTL BAR CODE
CD-ROM DRIVE	PLEXTOR	PX-12TSI	12TSI114138	EQNPX12TSI	INTERNAL RIBBON	9009
CPU	INTEL	PENTIUM 166 MHZ	N/A	N/A	N/A	7557
FLOPPY DRIVE	PANASONIC	JU-256A2236P	00052435	N/A	INTERNAL RIBBON	900597
HARD DRIVE	QUANTUM	FIREBALL ST	153725443639	N/A	INTERNAL RIBBON	8734
MOTHERBOARD	INTEL	HITMAN	GRCO124721M	N/A	INTERNAL RIBBON	900586
POWER SUPPLY	ASTEC	ATX 147-3515	2500019298	N/A	SHIELDED POWER	900579
VIDEO CARD	STB SYSTEMS, INC.	VIRGE GX	210-0262-001	DoC	SHIELDED I/O	6947

1.4 CONFIGURATION OF TESTED SYSTEM

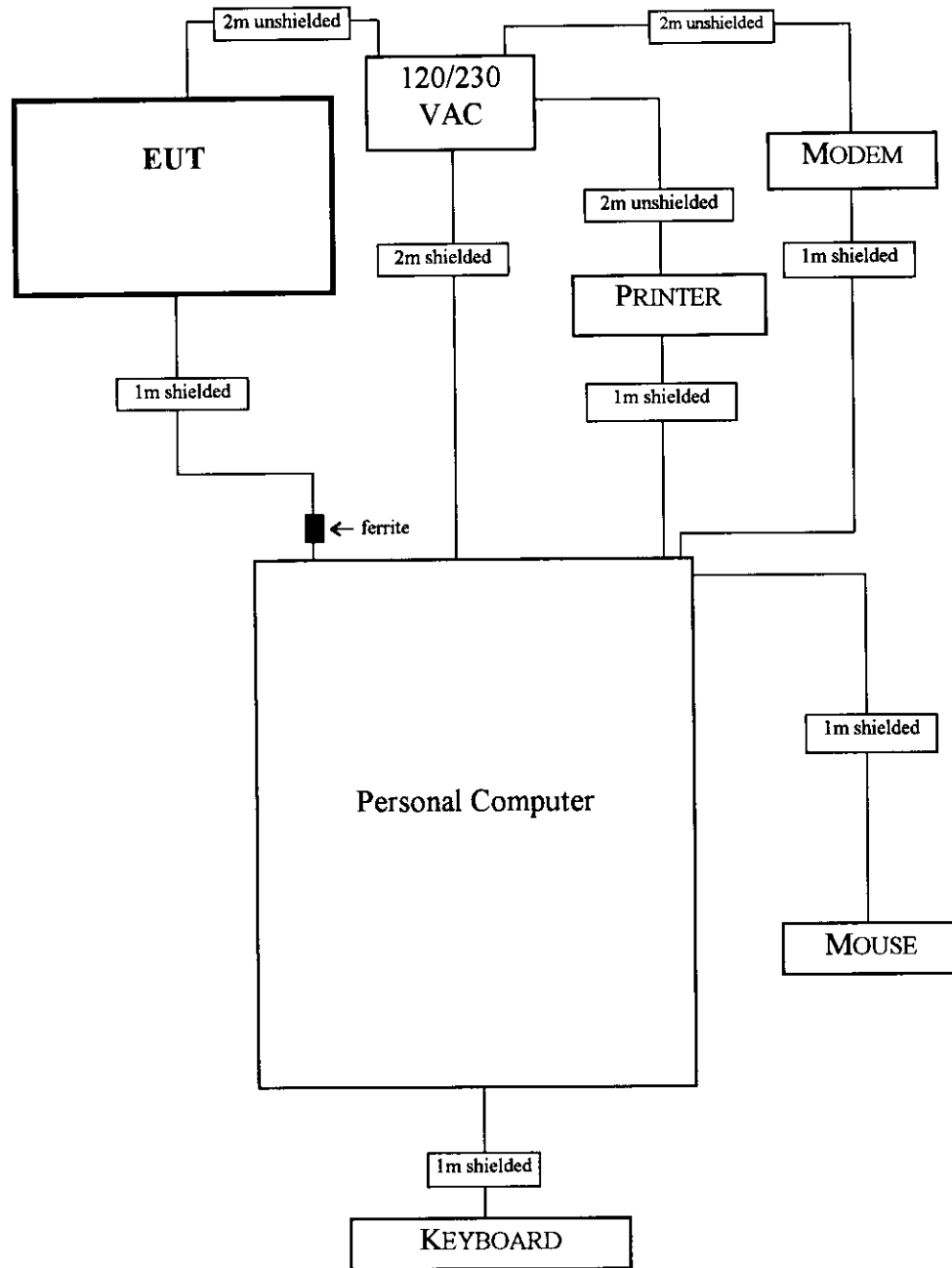

1.5 TEST METHODOLOGY

Both conducted and radiated testing were performed according to the procedures in ANSI C63.4 1992. Radiated testing was performed at an antenna to EUT distance of 10 meters.

1.6 TEST FACILITY

The open area test site and conducted measurement facility used to collect the radiated data is located on the parking lot of Rhein Tech Laboratories, Inc., 360 Herndon Parkway, Suite 1400 in Herndon, Virginia. This site has been fully described in a report dated June 24, 1996, submitted to and approved by the Federal Communication Commission to perform AC line conducted and radiated emissions testing (ANSI C63.4 1992).

3.0 SYSTEM TEST CONFIGURATION

3.1 JUSTIFICATION

The system was configured for testing in a typical fashion (as a customer would normally use it). Worst case conducted and radiated emissions are presented in 1024 x 768 @ 85 Hz, and 1280 x 1024 @ 60 Hz.
CPU speed: 166 MHz.

The host computer was tested with the serial ports, parallel port, mouse port, and keyboard port attached to external peripherals. The monitor (EUT) was investigated as powered from the wall outlet since there is no auxiliary power outlet on the host computer.

3.2 EUT EXERCISE SOFTWARE

The EUT exercise program used during radiated and conducted testing has been designed to exercise the various system components in a manner similar to a typical use. The software, contained on the hard disk drive, sequentially exercises each system component. 1) an H prints on the monitor, 2) an H prints on the printer 3) an H is sent to serial ports, 4) a file is read from the floppy diskette, 5) a file is read from the hard drive and any other hard drive present, 6) a file is read from the CD-ROM drive. In cases that implement the use of Universal Serial Bus (USB) ports, a looped batch program is initiated to render a continuous flow of data through the USB ports. The complete cycle takes less than one second and is repeated continuously. Systems that utilize network cards are connected to a server and are configured to transmit and receive packets of data continuously. As the keyboard and mouse are strictly input devices, no data was transmitted to them during test. They are, however, continuously scanned for data input activity.

3.3 SPECIAL ACCESSORIES

The end user is advised in the User's Manual to use the same type cables as described in Table 1 of this report.

3.4 CONFORMANCE STATEMENT

I, the undersigned, hereby declare that the equipment tested and referenced in this report conforms to the identified standard(s) as described in this attached test record. The modifications on the following page were made to the equipment during testing in order to achieve compliance with these standards.

Furthermore, there was no deviation from, additions to or exclusions from the ANSI C63.4 test methodology.

Signature: _____

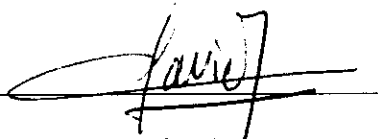

Date: July 10, 1998

Typed/Printed Name: Bruno Clavier

Position: Quality Manager
(NVLAP Signatory)

 Accredited by the National Voluntary Accreditation Program for the specific scope of accreditation under Lab Code 20061-0.

Note: This report may not be used by the client to claim product endorsement by NVLAP or any agency of the U.S. Government.

Statement of manufacturer's Representative

Company Name : Korea Data Systems Co., Ltd.
Representative's Name : H. R. Lee
Product(Model Name)Name : 17" Monitor(KD-1731)
Intended FCC ID : EVGKD-1731
Date Tested : July 8, 1998

I hereby warrant that the test sample is representative of the product to be marketed
That the test system configuration is representative of the product's intended use, and
that the following modifications were made to the KD-1731 in order to comply with
the standards described in the attached report:

1. Connected one ground wire between neck cover and FBT heat sink.
2. Connected two ground wire between neck cover and CRT band(Top).
3. Added one ferrite core on G4 wire.
4. Changed the BC205,206,207,208 from jump wire to ferrite bead.
5. Connected one ground plate between neck cover and CRT neck band.

Hwa Ryong Lee

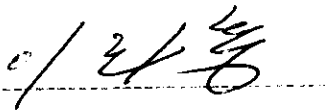

6.0 CONDUCTED EMISSION DATA

The initial step in collecting conducted data is a spectrum analyzer peak scan of the measurement range. If the conducted emissions exceed the average limit with the instrument set to the quasi-peak mode, then measurements are made in the average mode.

The conducted test was performed with the EUT exercise program loaded, and the emissions were scanned between 150 kHz to 30 MHz on the NEUTRAL SIDE and HOT SIDE, herein referred to as L1 and L2, respectively.

TABLE 2: CONDUCTED EMISSIONS 1024 X 768 @ 85 HZ

NEUTRAL SIDE (Line 1)

EMISSION FREQUENCY (MHz)	TEST DETECTOR (1)	ANALYZER READING (dBuV)	SITE CORRECTION FACTOR (dB)	EMISSION LEVEL (dBuV)	EN55022 / CISPR22 QUASI PEAK LIMIT (dBuV)	EN55022 / CISPR22 QUASI PEAK MARGIN (dBuV)	EN55022 / CISPR22 AVERAGE LIMIT (dBuV)	EN55022 / CISPR22 AVERAGE MARGIN (dBuV)
0.169	Pk	45.5	0.9	46.4	65.0	-18.6	55.0	-8.6
0.206	Pk	44.6	0.8	45.4	63.4	-18.0	53.4	-8.0
0.277	Pk	38.2	0.7	38.9	60.9	-22.0	50.9	-12.0
2.608	Pk	36.3	1.3	37.6	56.0	-18.4	46.0	-8.4
12.030	Pk	42.2	2.8	45.0	60.0	-15.0	50.0	-5.0
21.542	Pk	31.8	3.8	35.6	60.0	-24.4	50.0	-14.4
24.345	Pk	39.2	4.0	43.2	60.0	-16.8	50.0	-6.8

HOT SIDE (Line 2)

EMISSION FREQUENCY (MHz)	TEST DETECTOR (1)	ANALYZER READING (dBuV)	SITE CORRECTION FACTOR (dB)	EMISSION LEVEL (dBuV)	EN55022 / CISPR22 QUASI PEAK LIMIT (dBuV)	EN55022 / CISPR22 QUASI PEAK MARGIN (dBuV)	EN55022 / CISPR22 AVERAGE LIMIT (dBuV)	EN55022 / CISPR22 AVERAGE MARGIN (dBuV)
0.169	Pk	46.0	0.4	46.4	65.0	-18.6	55.0	-8.6
0.205	Pk	44.1	0.4	44.5	63.4	-18.9	53.4	-8.9
0.277	Pk	36.5	0.5	37.0	60.9	-23.9	50.9	-13.9
2.472	Pk	34.1	1.4	35.5	56.0	-20.5	46.0	-10.5
12.030	Pk	42.9	3.1	46.0	60.0	-14.0	50.0	-4.0
12.030	Qp	40.5	3.1	43.6	60.0	-16.4	50.0	-6.4
12.030	Av	22.2	3.1	25.3	60.0	-34.7	50.0	-24.7
20.250	Pk	41.6	4.3	45.9	60.0	-14.1	50.0	-4.1

⁽¹⁾Pk = Peak; QP = Quasi-Peak; Av = Average

TEST PERSONNEL:

Signature:  Date: 7/6/98

Typed/Printed Name: Robert Thomson

TABLE 3: CONDUCTED EMISSIONS 1280 x 1024 @ 60 HZ**NEUTRAL SIDE (Line 1)**

EMISSION FREQUENCY (MHz)	TEST DETECTOR (1)	ANALYZER READING (dBuV)	SITE CORRECTION FACTOR (dB)	EMISSION LEVEL (dBuV)	EN55022 / CISPR22 QUASI PEAK LIMIT (dBuV)	EN55022 / CISPR22 QUASI PEAK MARGIN (dBuV)	EN55022 / CISPR22 AVERAGE LIMIT (dBuV)	EN55022 / CISPR22 AVERAGE MARGIN (dBuV)
0.157	Pk	49.0	0.9	49.9	65.6	-15.7	55.6	-5.7
0.256	Pk	36.4	0.7	37.1	61.6	-24.5	51.6	-14.5
0.708	Pk	31.3	0.7	32.0	56.0	-24.0	46.0	-14.0
12.090	Pk	39.9	2.8	42.7	60.0	-17.3	50.0	-7.3
24.321	Pk	39.7	4.0	43.7	60.0	-16.3	50.0	-6.3
27.104	Pk	38.0	4.0	42.0	60.0	-18.0	50.0	-8.0

HOT SIDE (Line 2)

EMISSION FREQUENCY (MHz)	TEST DETECTOR (1)	ANALYZER READING (dBuV)	SITE CORRECTION FACTOR (dB)	EMISSION LEVEL (dBuV)	EN55022 / CISPR22 QUASI PEAK LIMIT (dBuV)	EN55022 / CISPR22 QUASI PEAK MARGIN (dBuV)	EN55022 / CISPR22 AVERAGE LIMIT (dBuV)	EN55022 / CISPR22 AVERAGE MARGIN (dBuV)
0.158	Pk	48.8	0.4	49.2	65.6	-16.4	55.6	-6.4
0.192	Pk	46.4	0.4	46.8	63.9	-17.1	53.9	-7.1
0.321	Pk	36.4	0.6	37.0	59.7	-22.7	49.7	-12.7
0.706	Pk	30.6	0.7	31.3	56.0	-24.7	46.0	-14.7
2.540	Pk	31.5	1.5	33.0	56.0	-23.0	46.0	-13.0
12.000	Pk	39.9	3.1	43.0	60.0	-17.0	50.0	-7.0
16.217	Pk	38.8	3.8	42.6	60.0	-17.4	50.0	-7.4
18.047	Pk	37.9	4.1	42.0	60.0	-18.0	50.0	-8.0
24.319	Pk	38.8	4.4	43.2	60.0	-16.8	50.0	-6.8
27.104	Pk	38.4	4.6	43.0	60.0	-17.0	50.0	-7.0

⁽¹⁾Pk = Peak; QP = Quasi-Peak; Av = Average

TEST PERSONNEL:

Signature:  Date: 7/6/98

Typed/Printed Name: Robert Thomson

7.0 RADIATED EMISSION DATA

The following data lists the significant emission frequencies, measured levels, correction factor (includes cable and antenna corrections), the corrected reading, plus the limit. Explanation of the Correction Factor is given in paragraph 7.1.

TABLE 4: RADIATED EMISSIONS 1024 X 768 @ 85 HZ

(Temperature: 70°F, Humidity: 69%)

EMISSION FREQUENCY (MHz)	ANTENNA POLARITY (H/V)	ANALYZER READING (dBuV) *	SITE CORRECTION FACTOR (dB/m)	EMISSION LEVEL (dBuV/m)	EN55022 / CISPR22 LIMIT (dBuV/m)	EN55022 / CISPR22 MARGIN (dBuV/m)
63.329	V	50.3	-28.0	22.3	30.0	-7.7
79.129	V	54.3	-31.1	23.2	30.0	-6.8
121.380	H	47.4	-25.4	22.0	30.0	-8.0
134.483	V	46.8	-26.9	19.9	30.0	-10.1
147.180	H	49.9	-28.8	21.1	30.0	-8.9
150.300	H	51.5	-29.0	22.5	30.0	-7.5
174.001	H	48.4	-27.0	21.4	30.0	-8.6
229.348	H	49.7	-24.1	25.6	30.0	-4.4

**All readings are quasi-peak, unless stated otherwise. See Appendix B for Radiated Test Methodology.*

TEST PERSONNEL:

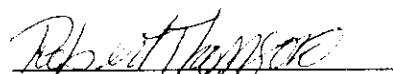
Signature: 

Date: 7/6/98

Typed/Printed Name: Robert Thomson

TABLE 5: RADIATED EMISSIONS 1280 x 1024 @ 60 HZ

(Temperature: 79°F, Humidity: 33%)

EMISSION FREQUENCY (MHz)	ANTENNA POLARITY (H/V)	ANALYZER READING (dBuV) *	SITE CORRECTION FACTOR (dB/m)	EMISSION LEVEL (dBuV/m)	EN55022 / CISPR22 LIMIT (dBuV/m)	EN55022 / CISPR22 MARGIN (dBuV/m)
54.288	V	48.4	-24.7	23.7	30.0	-6.3
72.354	V	54.9	-30.6	24.3	30.0	-5.7
81.384	V	51.9	-30.9	21.0	30.0	-9
126.576	V	49.7	-25.8	23.9	30.0	-6.1
127.637	V	51.1	-25.9	25.2	30.0	-4.8
135.588	V	45.7	-27.1	18.6	30.0	-11.4
153.688	H	52.4	-28.6	23.8	30.0	-6.2
171.738	V	52.4	-27.2	25.2	30.0	-4.8
180.768	V	46.5	-27.1	19.4	30.0	-10.6
234.994	H	54.0	-23.9	30.1	37.0	-6.9
244.018	H	50.5	-23.2	27.3	37.0	-9.7
253.048	H	47.1	-23.3	23.8	37.0	-13.2
262.108	H	44.9	-22.7	22.2	37.0	-14.8
298.246	H	45.0	-22.1	22.9	37.0	-14.1
307.270	V	45.1	-21.7	23.4	37.0	-13.6

**All readings are quasi-peak, unless stated otherwise. See Appendix B for Radiated Test Methodology.*

TEST PERSONNEL:

Signature: _____

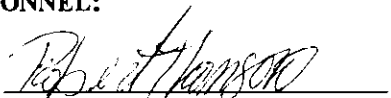

Date: 7/7/98

Typed/Printed Name: Robert Thomson

7.1 Field Strength Calculation

The field strength is calculated by adding the Antenna Factor and Cable Factor, and subtracting the Amplifier Gain (if any) from the measured reading. The basic equation with a sample calculation is as follows:

$$\text{FI(dBuV/m)} = \text{SAR(dBuV)} + \text{SCF(dB/m)}$$

FI = Field Intensity
 SAR = Spectrum Analyzer Reading
 SCF = Site Correction Factor

The Site Correction Factor (SCF) used in the above equation is determined empirically, and is expressed in the following equation:

$$\text{SCF(dB/m)} = -\text{PG(dB)} + \text{AF(dB/m)} + \text{CL(dB)}$$

SCF = Site Correction Factor
 PG = Pre-amplifier Gain
 AF = Antenna Factor
 CL = Cable Loss

The field intensity in microvolts per meter can then be determined according to the following equation:

$$\text{FI(uV/m)} = 10^{\text{FI(dBuV/m)}/20}$$

For example, assume a signal at a frequency of 125 MHz has a received level measured as 49.3 dBuV. The total Site Correction Factor (antenna factor plus cable loss minus preamplifier gain) for 125 MHz is -11.5 dB/m. The actual radiated field strength is calculated as follows:

$$49.3 \text{ dBuV} - 11.5 \text{ dB/m} = 37.8 \text{ dBuV/m}$$

$$10^{37.8/20} = 10^{1.89} = 77.6 \text{ uV/m}$$

8.0 PHOTOS OF TESTED EUT

The following photos are attached:

FIGURE 3: Monitor front

FIGURE 4: Back of monitor, showing label

FIGURE 5: Left side of monitor

FIGURE 6: Right side of monitor

FIGURE 7: Bottom of monitor

FIGURE 8: Cover interior of monitor

FIGURE 9: Bezel interior

FIGURE 10: Top of monitor, cover removed

FIGURE 11: Bottom monitor, cover removed

FIGURE 12: Left side of monitor, cover removed

FIGURE 13: Right side of monitor, cover removed

FIGURE 14: Back of monitor, cover removed, CRT neck board with shielded, solder side

FIGURE 15: Back side of CRT tube

FIGURE 16: Main board, component side

FIGURE 17: Main board, solder side

FIGURE 18: CRT neck, component side

FIGURE 19: CRT neck, solder side

APPENDIX A: Emissions Equipment List**TABLE 6: Emissions Equipment List**

DESCRIPTION	MANUFACTURER	MODEL NUMBER	SERIAL NUMBER	CAL. LAB
AMPLIFIER	HEWLETT PACKARD	11975A	2304A00348	TEST EQUITY
AMPLIFIER (S/A 1)	RHEIN TECH	PR-1040	N/A	RTL
AMPLIFIER (S/A 2)	RHEIN TECH	RTL2	N/A	RTL
AMPLIFIER (S/A 3)	RHEIN TECH	8447F	2944A03783	RTL
AMPLIFIER (S/A 4)	RHEIN TECH	8447D	2727A05397	RTL
BICONICAL/LOG ANTENNA 1	ANTENNA RESEARCH	LPB-2520	1037	LIBERTY LABS
BICONICAL/LOG ANTENNA 2	ANTENNA RESEARCH	LPB-2520	1036	LIBERTY LABS
FIELD SITE SOURCE	EMCO	4610	9604-1313	RTL
FILTER (ROOM 1)	SOLAR	8130	947305	RTL
FILTER (ROOM 2)	SOLAR	8130	947306	RTL
HARMONIC MIXER 1	HEWLETT PACKARD	11970K	2332A00563	TELOGY
HARMONIC MIXER 2	HEWLETT PACKARD	11970A	2332A01199	TELOGY
HORN ANTENNA 1	EMCO	3160-10	9606-1033	EMCO
HORN ANTENNA 2	EMCO	3160-9	9605-1051	EMCO
HORN ANTENNA 3	EMCO	3160-7	9605-1054	EMCO
HORN ANTENNA 4	EMCO	3160-8	9605-1044	EMCO
HORN ANTENNA 5	EMCO	3160-03	9508-1024	EMCO
LISN (ROOM 1/L1)	SOLAR	7225-1	N/A	ACUCAL
LISN (ROOM 1/L2)	SOLAR	7225-1	N/A	ACUCAL
LISN (ROOM 2/L1)	SOLAR	7225-1	900078	ACUCAL
LISN (ROOM 2/L2)	SOLAR	7225-1	900077	ACUCAL
PRE-AMPLIFIER	HEWLETT PACKARD	8449B OPT	3008A00505	TELOGY
QUASI-PEAK ADAPTER (S/A 1)	HEWLETT PACKARD	85650A	3145A01599	ACUCAL
QUASI-PEAK ADAPTER (S/A 2)	HEWLETT PACKARD	85650A	2811A01276	ACUCAL
QUASI-PEAK ADAPTER (S/A 3)	HEWLETT PACKARD	85650A	2521A00473	ACUCAL
QUASI-PEAK ADAPTER (S/A 4)	HEWLETT PACKARD	85650A	2521A01032	ACUCAL
RF PRESELECTOR (S/A 1)	HEWLETT PACKARD	85685A	3146A01309	ACUCAL
SIGNAL GENERATOR (HP)	HEWLETT PACKARD	8660C	1947A02956	ACUCAL
SIGNAL GENERATOR (WAVETEK)	WAVETEK	3510B	4952044	ACUCAL
SPECTRUM ANALYZER 1	HEWLETT PACKARD	8566B	3138A07771	ACUCAL
SPECTRUM ANALYZER 2	HEWLETT PACKARD	8567A	2841A00614	ACUCAL
SPECTRUM ANALYZER 4	HEWLETT PACKARD	8567A	2727A00535	ACUCAL
TUNABLE DIPOLE	EMCO	3121	274	LIBERTY LABS

APPENDIX B: Conducted and Radiated Test Methodology

CONDUCTED EMISSIONS MEASUREMENTS

The power line conducted emission measurements were performed in a Series 81 type shielded enclosure manufactured by Rayproof. The EUT was assembled on a wooden table 80 centimeters high. Power was fed to the EUT through a 50 ohm / 50 microhenry Line Impedance Stabilization Network (LISN). The EUT LISN was fed power through an A.C. filter box on the outside of the shielded enclosure. The filter box and EUT LISN housing are bonded to the ground plane of the shielded enclosure. A second LISN, the peripheral LISN, provides isolation for the EUT test peripherals. This peripheral LISN was also fed A.C. power. A metal power outlet box, which is bonded to the ground plane and electrically connected to the peripheral LISN, powers the EUT host peripherals.

The spectrum analyzer was connected to the A.C. line through an isolation transformer. The 50-ohm output of the EUT LISN was connected to the spectrum analyzer input through a Solar 400 kHz high-pass filter. The filter is used to prevent overload of the spectrum analyzer from noise below 400 kHz. Conducted emission levels were measured on each current-carrying line with the spectrum analyzer operating in the CISPR quasi-peak mode (or peak mode if applicable). The analyzer's 6 dB bandwidth was set to 9 kHz. No video filter less than 10 times the resolution bandwidth was used. Average measurements are performed in linear mode using a 10 kHz resolution bandwidth, a 1 Hz video bandwidth, and by increasing the sweep time in order to obtain a calibrated measurement. The emission spectrum was scanned from (150/450) kHz to 30 MHz. The highest emission amplitudes relative to the appropriate limit were measured and have been recorded in this report.

RADIATED EMISSIONS MEASUREMENTS

Before final measurements of radiated emissions were made on the open-field three/ten meter range, the EUT was scanned indoors at one meter and three meter distances, in order to determine its emissions spectrum signature. The physical arrangement of the test system and associated cabling was varied in order to determine the effect on the EUT's emissions in amplitude, direction and frequency. This process was repeated during final radiated emissions measurements on the open-field range, at each frequency, in order to insure that maximum emission amplitudes were attained.

Final radiated emissions measurements were made on the three-meter, open-field test site. The EUT was placed on a nonconductive turntable approximately 0.8 meters above the ground plane. The spectrum was examined from 30 MHz to 1000 MHz using a Hewlett Packard 8566B spectrum analyzer, a Hewlett Packard 85650A quasi-peak adapter, and an Antenna Research bilog antenna. In order to gain sensitivity, an RTL PR-1040 preamplifier was connected in series between the antenna and the input of the spectrum analyzer.

At each frequency, the EUT was rotated 360 degrees, and the antenna was raised and lowered from one to four meters in order to determine the maximum emission levels. Measurements were taken using both horizontal and vertical antenna polarizations. The spectrum analyzer's 6 dB bandwidth was set to 120 kHz, and the analyzer was operated in the CISPR quasi-peak detection mode. No video filter less than 10 times the resolution bandwidth was used. When any clock exceeds 108 MHz, the EUT was tested between 1 to 2 Gigahertz in peak mode with the resolution bandwidth set at 1 MHz as stated in ANSI C63.4. The highest emission amplitudes relative to the appropriate limit were measured and recorded in this report.

Note: Rhein Tech Laboratories, Inc. has implemented procedures to minimize errors that occur from test instruments, calibration, procedures, and test setups. Test instrument and calibration errors are documented from the manufacturer or calibration lab. Other errors have been defined and calculated within the Rhein Tech quality manual, section 6.1. Rhein Tech implements the following procedures to minimize errors that may occur: yearly as well as daily calibration methods, technician training, and emphasis to employees on avoiding error.