

祥晟田電子

HIGH-TEK GROUP

APPROVAL SHEET

CUSTOMER : 大眾電腦股份有限公司

PART NO : 21-92232-01

REF. NO : _____ DATE : 92.09.30

CUSTOMER APPROVEAL

APPROVED	CHECKED	ISSUED

HIGH-TEK GROUP

APPROVED	CHECKED	ISSUED
		



MH47 Model Antenna Materials List

1. MH13 Model Antenna Materials List----- Page 2
2. Antenna Test Report----- Page 3
3. HIGH-TEK Drawing----- Page 12
4. I-PEX Connector Drawing & SPEC.----- Page 15
5. Cable SPEC.----- Page 40
 - a. Coaxial cable/Length:
 - Coaxial cable: 0.7DS-PBE (1.13 COLOR)
 - Left Antenna: 709.5mm
 - Right Antenna: 501.6mm
 - c. Diameter (Φ) & Vendor
 - Diameter: Φ 1.13mm
 - Vendor: Sumitomo
6. Antenna Type & Materials----- Page 43
 - a. Type: PIFA
 - b. Materials: 0.3t Metal Sheet
7. Sponge & Type SPEC.----- Page 44
8. Heat Shrink Tube SPEC.----- Page 52



HIGH-TEK HARNESS ENTERPRISE

Antenna Testing Report

FIC MH47

Prepared by

Approved by

Rober Ku

General Information

- Measurement Resume**

<i>Date</i>	<i>Engineer</i>	<i>2.4~2.5 GHz</i>	<i>5.15~5.35 GHz</i>	<i>5.47~5.725 GHz</i>	<i>5.725~5.825 GHz</i>
92/07/02	Rober Ku	✓	✓		

- Antenna specifications: maximum size, unit: mm**

<i>PIFA Type</i>	<i>Length</i>	<i>Width</i>	<i>Height</i>	<i>Cable length</i>
<i>Left Side</i>	42	4	4.5	710
<i>Right Side</i>	42	4	4.5	502

- Measurement Setup & Environment**

<i>Temp.</i>	<i>Humidity</i>	<i>Instrument</i>	<i>System</i>	<i>Entry</i>
20 °C	50%	<i>VNA HP8753ES, 7x4x4 m anechoic chamber</i>	<i>NSI antenna measurement system</i>	<i>VSWR, Return Loss, Radiation pattern</i>

Coordinate Definition

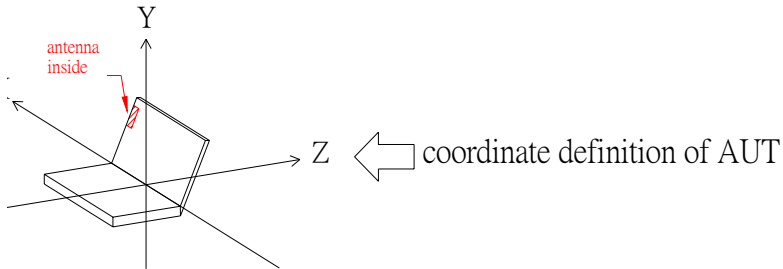

HORN ANTENNA

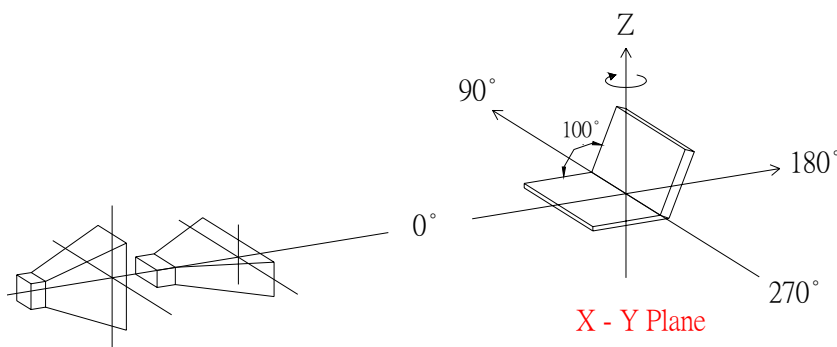
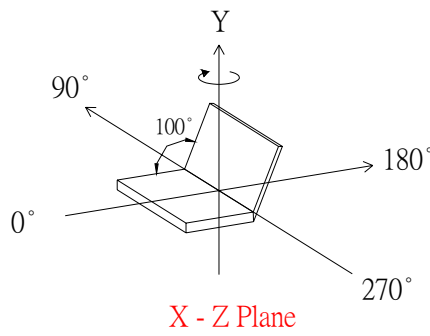
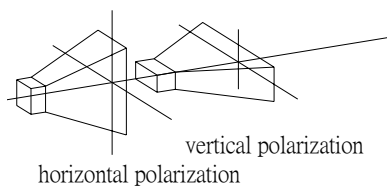

Spectrum Allocation in worldwide WLAN

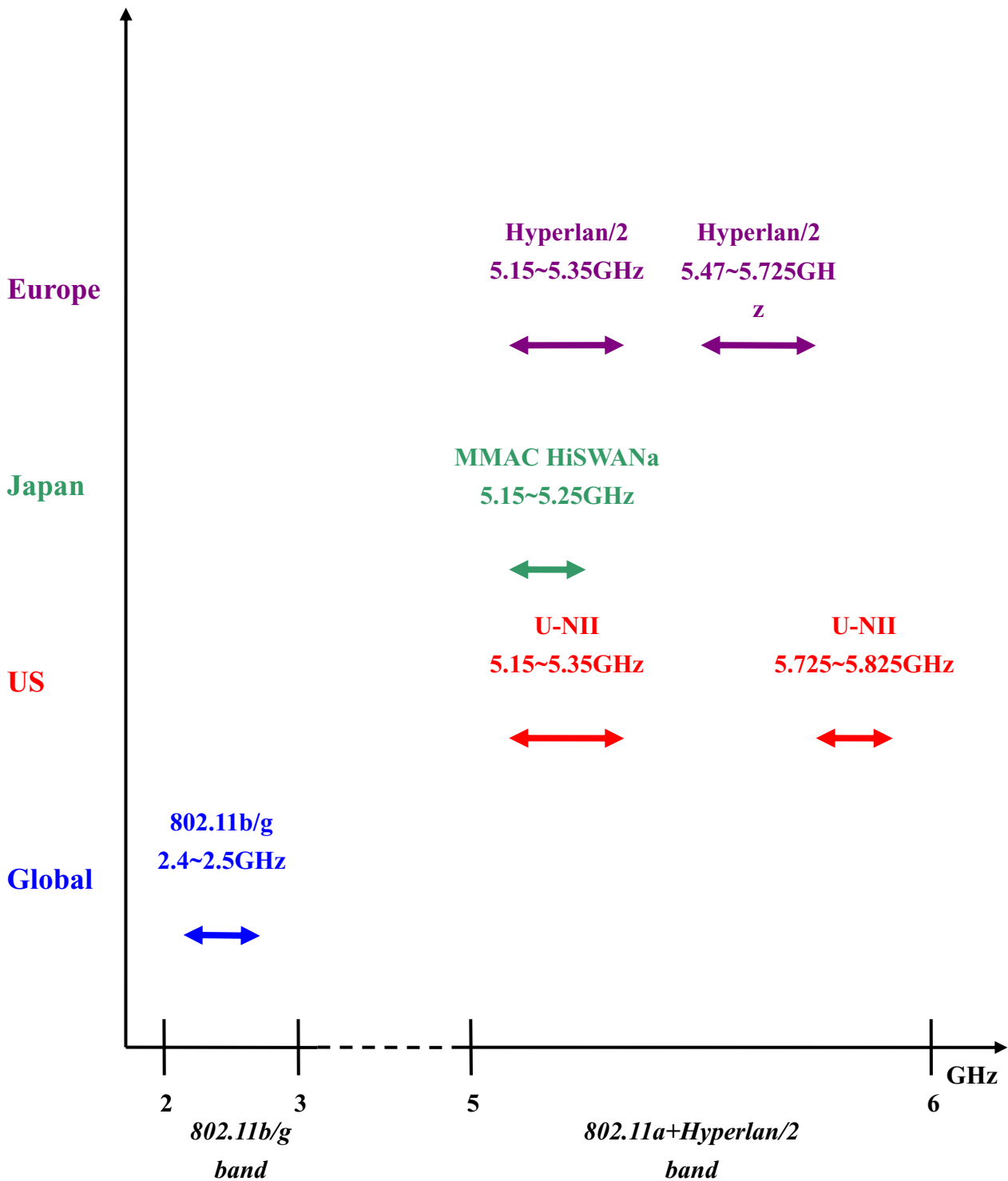

Typical Performance of Antenna

I. Typical Performance Table

	2.4~2.5GHz	5.15~5.25GHz	5.15~5.35GHz	5.47~5.825GHz
VSWR	1.02	1.21	1.21	
Peak Gain	1.54 dBi	0.26 dBi	0.26 dBi	
Average Gain	-1.86 dBi	-3.58 dBi	-3.58 dBi	

II. Antenna Type

Position	Main Antenna (Right-side Antenna)	Aux Antenna (Left-side Antenna)
Antenna Type	PIFA	PIFA
Material	Metal sheet	Metal sheet

III. VSWR

	2.4GHz ISM 2.4~2.5GHz			JAPAN 5.15~5.25GHz		U-NII,Hyperlan/2 5.150~5.35GHz			U-NII+HiperLAN/2 5.47~5.825GHz		
	2.40	2.45	2.50	5.15	5.25	5.15	5.25	5.35	5.47	5.6	5.825
MAIN	1.16	1.02	1.18	1.21	1.26	1.21	1.26	1.34			
AUX	1.07	1.28	1.34	1.56	1.35	1.56	1.35	1.26			

IV. Peak Gain and Average Gain

Gain (dBi)	Freq (GHz)	2.4GHz ISM 2.4~2.5GHz			JAPAN 5.15~5.25GHz		U-NII,Hyperlan/2 5.150~5.350GHz			U-NII+HiperLAN/2 5.470~5.825GHz		
		2.40	2.45	2.50	5.15	5.25	5.15	5.25	5.35	5.47	5.6	5.825
MAIN	Peak	1.54	0.24	-0.55	-0.81	-0.18	-0.81	-0.18	0.05			
	Avg	-1.86	-2.27	-2.54	-4.49	-3.95	-4.49	-3.95	-3.60			
AUX	Peak	0.76	0.28	-1.27	-1.65	0.26	-1.65	0.26	0.35			
	Avg	-2.47	-2.63	-3.34	-4.72	-3.58	-4.72	-3.58	-3.58			

Return Loss & VSWR

L-Antenna

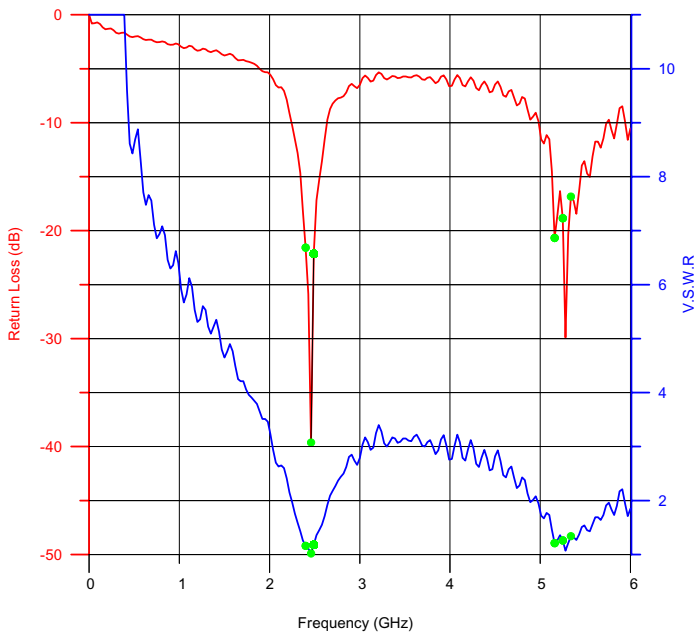

2.4~2.5 GHz Center freq. @MHz		2450
Band Width @MHz		300
5.15~5.35 GHz Center freq. @MHz		5250
Band Width @MHz		1320
freq.	Return Loss(dB)	VSWR
2.4 GHz	-21.57	1.16
2.45 GHz	-39.63	1.02
2.5 GHz	-22.14	1.18
5.15 GHz	-20.67	1.21
5.25 GHz	-18.85	1.26
5.35 GHz	-16.84	1.34

R-Antenna

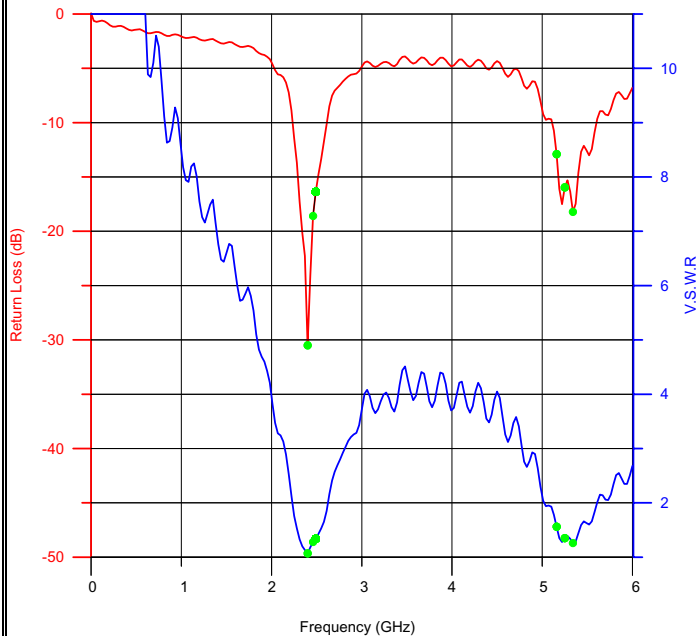

2.4~2.5 GHz Center freq. @MHz		2450
Band Width @MHz		210
5.15~5.35 GHz Center freq. @MHz		5.25
Band Width @MHz		970
freq.	Return Loss(dB)	VSWR
2.4 GHz	-30.5	1.07
2.45 GHz	-18.59	1.28
2.5 GHz	-16.36	1.34
5.15 GHz	-12.9	1.56
5.25 GHz	-15.96	1.35
5.35 GHz	-18.22	1.26

Radiation Pattern I

L-antenna(2.4~2.5 GHz)

Note: *horizontal polarization plots in the red line and vertical polarization in the blue one*

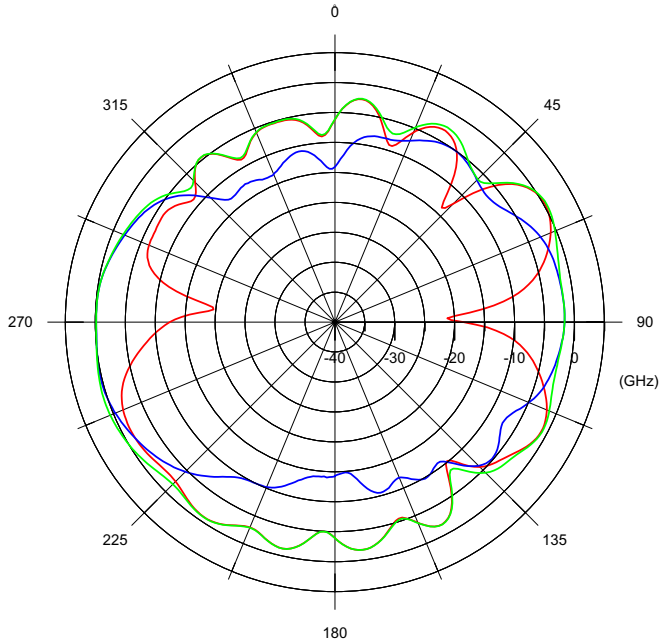

Average Gain And Peak Gain (On Azimuth Plane)

XZ- Plane

Peak Gain (dBi)	0.24
Peak Gain (dBi)	0.216
Avg. Gain (dBi)	-2.27

Note: *The green line means the average gain of vertical and horizontal polarization.*

R-antenna(2.4~2.5 GHz)

Average Gain And Peak Gain (On Azimuth Plane)

XZ- Plane

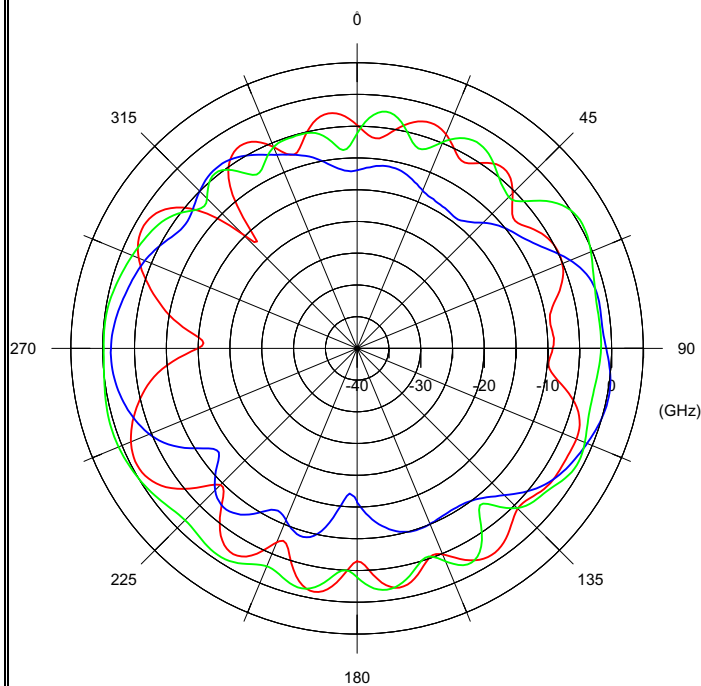

Peak Gain (dBi)	-0.834
Peak Gain (dBi)	0.281
Avg. Gain (dBi)	-2.63

Radiation Pattern II

L-antenna(5.15~5.35 GHz)

Note: *horizontal polarization plots in the red line and vertical polarization in the blue one*

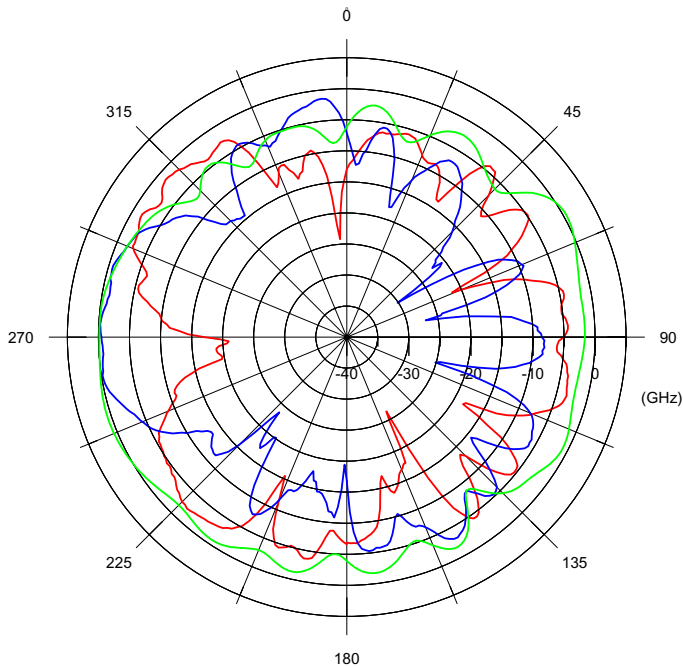

Average Gain And Peak Gain (On Azimuth Plane)

XZ- Plane

Peak Gain (dBi)	-1.339
Peak Gain (dBi)	-0.183
Avg. Gain (dBi)	-3.95

Note: *The green line means the average gain of vertical and horizontal polarization.*

R-antenna(5.15~5.35 GHz)

Average Gain And Peak Gain (On Azimuth Plane)

XZ- Plane

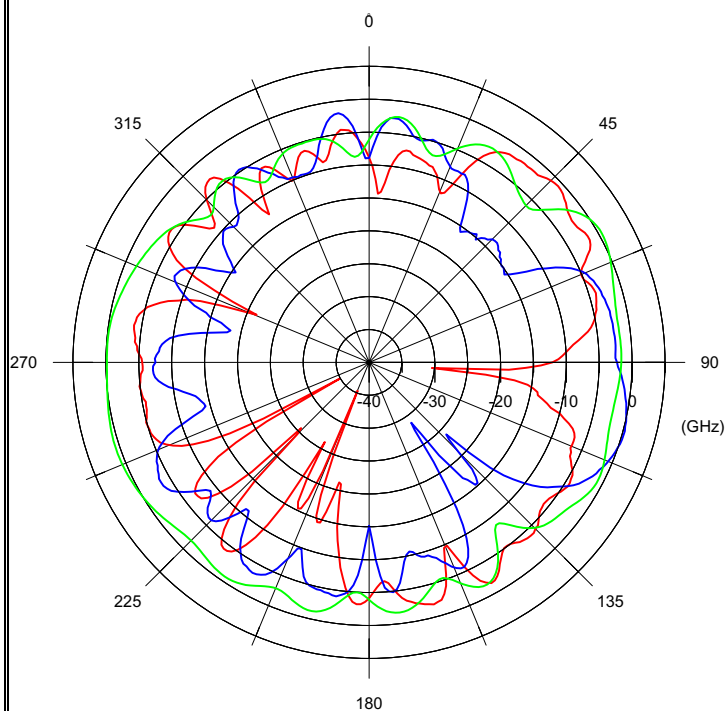

Peak Gain (dBi)	-0.728
Peak Gain (dBi)	0.259
Avg. Gain (dBi)	-3.58

Appendix

- VSWR :** *Voltage standing wave ratio on a transmission line in an antenna system. The ratio of the forward to reflected voltage on the line, and not a power ratio. A VSWR of 1:1 occurs when all parts of the antenna system are matched correctly.*
- Return Loss :** *When the load is mismatched, then, not all of the available power from the generator is delivered to the load. This 'loss' is called return loss(RL).*
- Radiation pattern :** *The radiation characteristics of an antenna as a function of spatial coordinates. Normally, the pattern is measured in the far-field region and is represented graphically.*
- Polarization :** *The sense of the wave radiated by an antenna. This can be horizontal, vertical, elliptical, or circular (left or right hand circularity), depending on the design and application. The polarization of the antenna is based on the orientation of the electric or E field component. The polarization must be matched between two antennas to receive the maximum field intensity. Dependent on the antenna type, it is possible to radiate linear, elliptical and circular polarizations.*
- Gain value :** *The increase in effective radiated power in the desired direction of the major lobe.*
- Peak gain :** *The highest gain value in 360 degrees, which means the antenna efficiency at this angle is the best.*
- Cable loss :** *When RF signal transmitting in the coaxial cable, due to the material of the cable, the power may dissipate into to the air in the form of heat. So when we try to measure the gain of an antenna, we have to offset the cable loss. The power loss of coaxial cable($\Phi=1.13$ mm) at 2.4~2.5 GHz is 3dB per 1000 mm and 5dB per 1000 mm at 5.15~5.35 GHz. In this case, the cable length of the right antenna is about 502 mm, so the cable loss when RF signal transmitting at 2.4~2.5 GHz is about 1.51 dB; and the one at 5.15~5.35 GHz is about 2.51dB. For the same reason, the cable length of the left antenna is about 710 mm, so the cable loss when RF signal transmitting at 2.4~2.5 GHz is about 2.13dB; and the loss at 5.15~5.35 GHz is about 3.55 dB. Which means we have to offset the cable loss to the gain value that we measure from the radiation pattern and that is the true antenna gain (G_a) we want.*

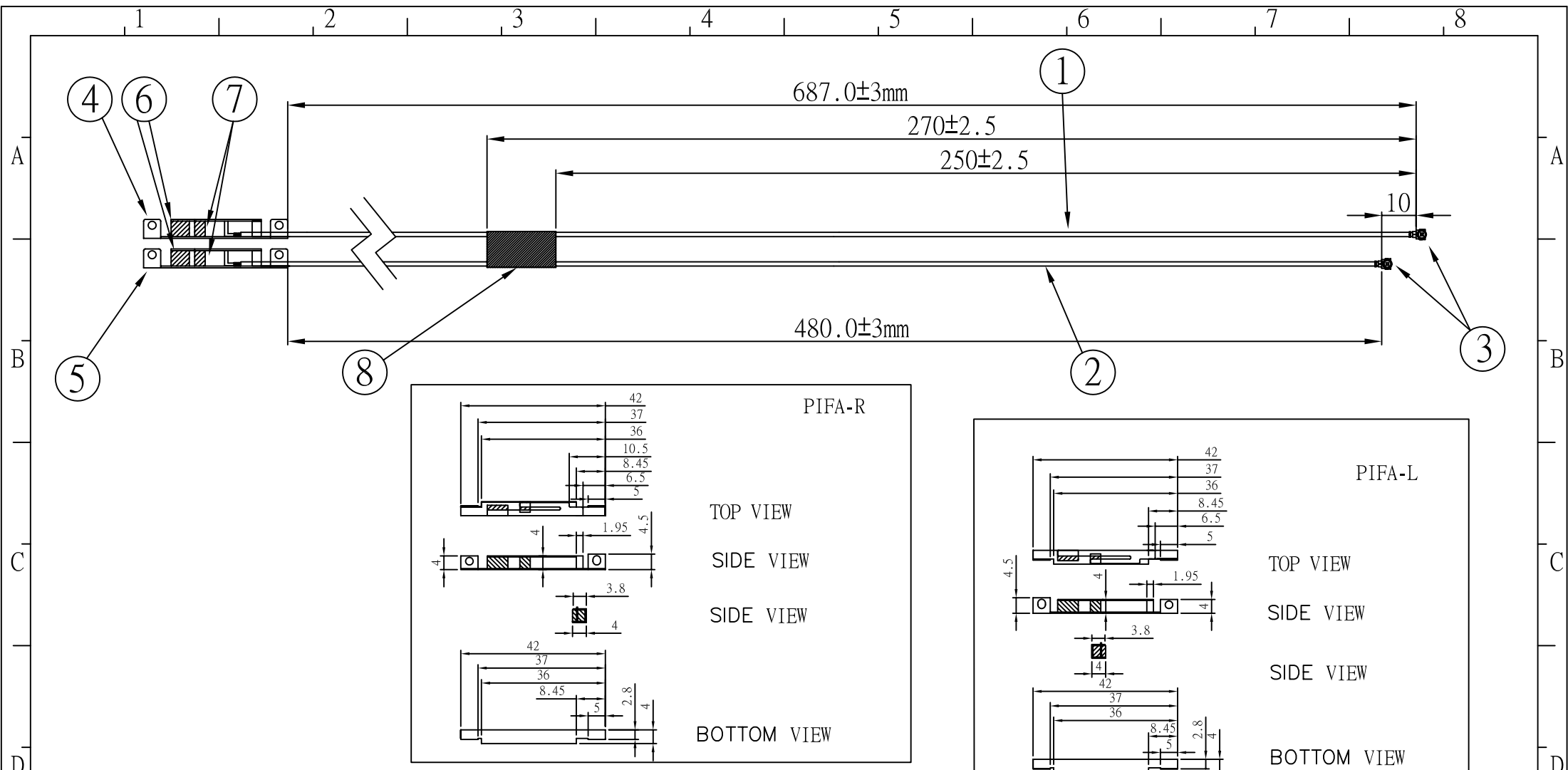

8	HEAT SHRINK TUBE	φ:2.0*20mm	1	HANBURG		
7	Poron	PR-064	2	Sheng Feng	3(W) * 3(L) * 3.4(T)	
6	Poron	PR-065	2	Sheng Feng	6(W) * 3(L) * 3.4(T)	
5	Metal (Antenna)	HV-194-FIC-R	1	Sheng Feng		
4	Metal (Antenna)	HV-195-FIC-L	1	Sheng Feng		
3	Connector	20278-111R-13	2	I-PEX		
2	Coaxial Cable	0.7-PBE(1.13 BLACK)	1	SUMITOMO		
1	Coaxial Cable	0.7-PBE(1.13 GRAY)	1	SUMITOMO		
ITEM	DESCRIPTION	VENDOR P/N	Q'TY	REMARK	REV.	DATE

RANGE	TOLERANCE	Dimensions for FIC MH47 Antenna	
OVER 300	±3.0	P/N: 21-92232-01	DRN NO.: 21-92232-01
101-300	±2.5	APPD:	DRN: Chih-Pan
51-100	±2.0	UNIT: M/M	SHEET: 3 OF 3
31-50	±1.5	天樺晟 電子股份有限公司 HIGH-TEK HARNESS GROUP	
BELOW 30	±1.0		

天樺晟 電子股份有限公司
HIGH-TEK HARNESS GROUP

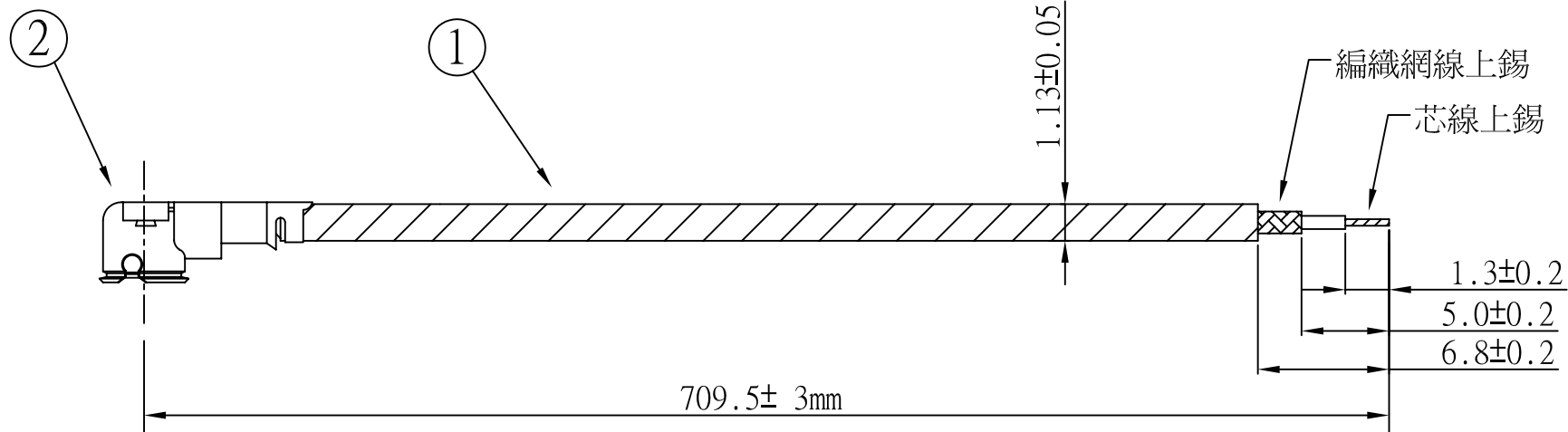

半成品圖

ITEM	DESCRIPTION	VENDOR P/N	Q'TY	REMARK	REV.	DATE	DESCRIPTION	RANGE	TOLERANCE	FIC MH47 model-L	
6								OVER 300	±3	P/N:	DRN NO:
5								101-300	±2.5	APPD:	DRN:
4								51-100	±2	UNIT: m/m	SHEET: 1 OF 1
3								31-50	±1.5	用樺晟 電子股份有限公司 HIGH-TEK HARNESS GROUP	
2	Connector	20278-111R-13	1	I-PEX				BELOW 30	±1		
1	Coaxial Cable	0.7DS-PBE (1.13 GRAY)	1	Sumitomo							

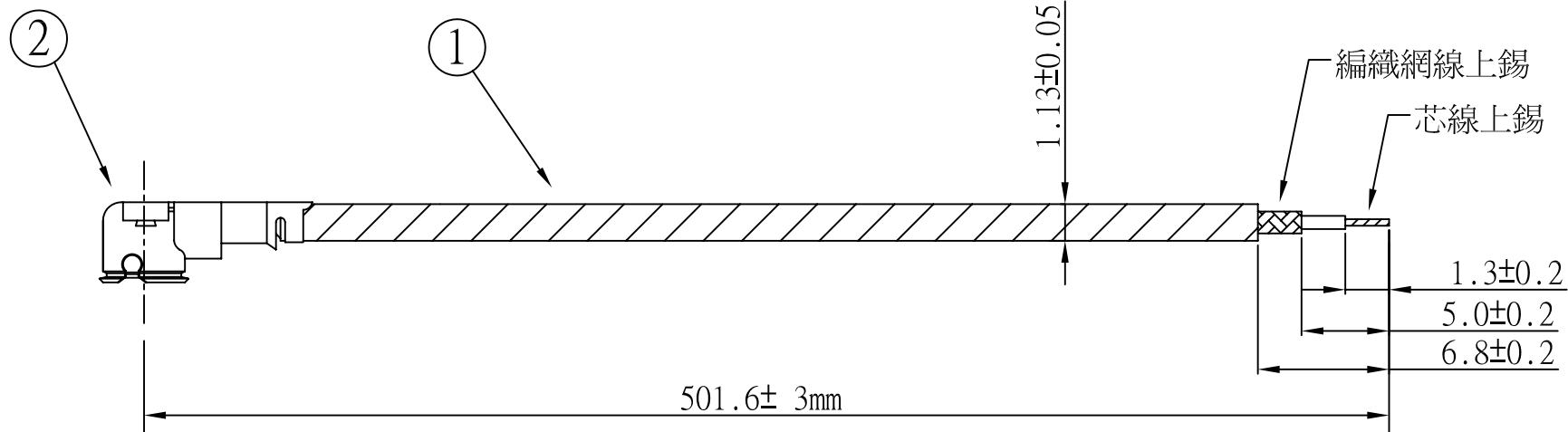

半成品圖

ITEM	DESCRIPTION	VENDOR P/N	Q'TY	REMARK	REV.	DATE	DESCRIPTION	RANGE	TOLERANCE	FIC MH47 model-R	
6								OVER 300	±3	P/N:	DRN NO:
5								101-300	±2.5	APPD:	DRN:
4								51-100	±2	UNIT: m/m	SHEET: 1 OF 1
3								31-50	±1.5	用樺晟 電子股份有限公司 HIGH-TEK HARNESS GROUP	
2	Connector	20278-111R-13	1	I-PEX				BELOW 30	±1		
1	Coaxial Cable	0.7DS-PBE (1.13 BLACK)	1	Sumitomo							

PART NO.
20278-**1R-**

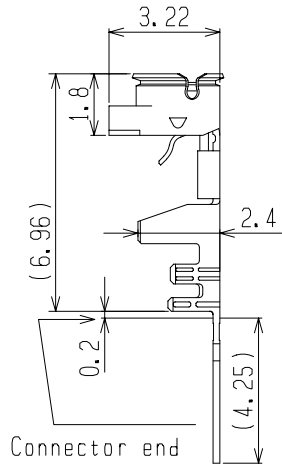
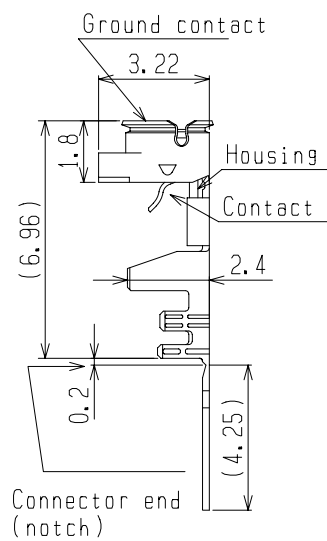
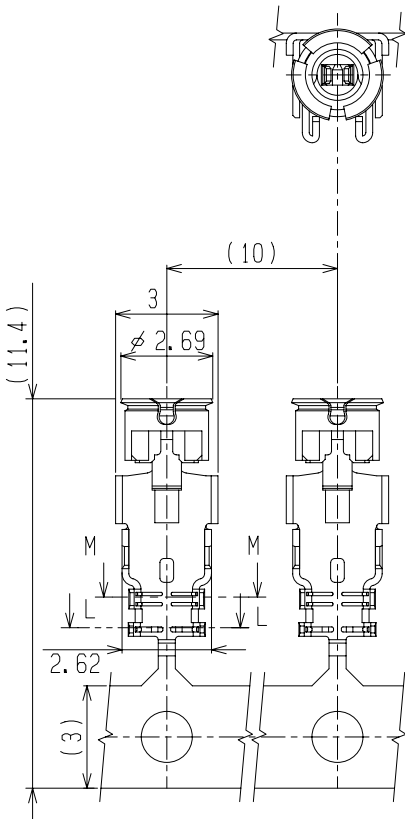

Part No.20278-101R-**
For hand tool
(with notch)

Part No.20278-111R-**
For semi auto
termination machine
(without notch)

GENERAL TOLERANCE	
6 MAX.	±0.2
6 OVER MAX. 30	±0.3
30 OVER MAX. 120	±0.5
ANGLE	±2'

					4	Z2023	K.O	JAN/30/02	E.K
					3	Z1256	K.O	NOV/14/01	K.K
9C	Z2239	K.O	NOV/15/02	E.K	2	Z1197	K.O	AUG/27/01	K.K
8C	Z2224	K.O	OCT/17/02	E.K	1	Z1118	K.O	JUN/26/01	K.K
7B	Z2180	K.O	JUL/29/02	E.K	0	Z1109	K.O	JUN/13/01	K.K
6B	Z2146	K.O	JUN/24/02	K.K	REV	ECN	BY	DATE	APP
5B	Z2117	A.H	MAY/17/02	K.K	REV. RECORD				
REV	ECN	BY	DATE	APP	SERIES No.		2814		

DESIGN'D BY	DATE
K.Ohbayashi	JUN/13/01
CHK'D BY	DATE
APP'D BY	DATE
K.Katabuchi	JUN/13/01
CUSTOMER COPY	PROJECTION

I-PEX Interconnect and Packaging Electronics TOKYO, JAPAN

TITLE: MHF series micro coaxial connector plug vertical (ground contact : gold plating)

SCALE	UNIT	DWG. No.	SHEET	REV.
6/1	mm	20278	1/3	9C

Part No.	20278-101R-08 20278-111R-08	20278-101R-13 20278-111R-13	20278-101R-32 20278-111R-32	20278-101R-18 20278-111R-18
Applicable cable nominal dimension	2.09±0.1 1.25±0.1 1.16±0.1	2.09±0.1 1.25±0.1 1.16±0.1	2.09±0.1 1.25±0.1 1.16±0.1	2.09±0.1 1.25±0.1 1.16±0.1
Jacket Outer conductor silver or tin plating Dielectric core Inner conductor silver plating				
Braided shield of Outer conductor 外部導体の編組	Single / 1重編組	Single / 1重編組	Double / 2重編組	Single / 1重編組
P/N of hand Tool	90187-008C	90187-013C	90187-032C	<Under developing>
P/N of semi auto termination machine	90213-008C	90213-013C	90213-032C	
Sect. M-M				
Sect. L-L				
Crimp Height	CH-1	1.34~1.40	1.34~1.40	Under developing
	CH-2	0.76~0.84	1.06~1.14	Under developing
	CH-3	0.85~0.97	1.15~1.35	Under developing

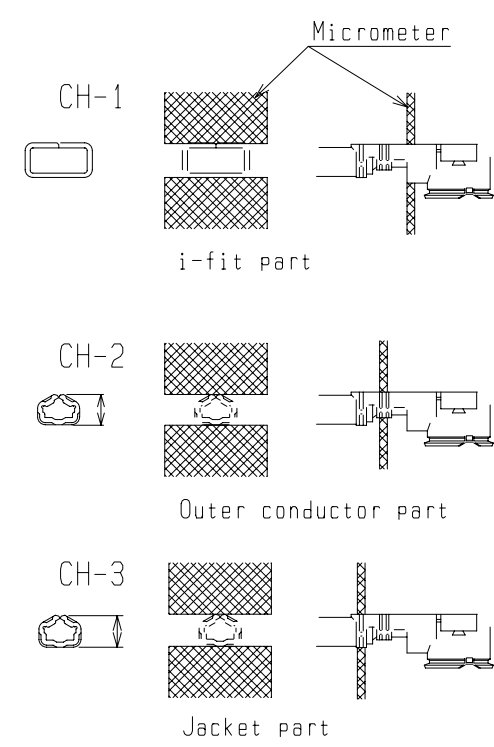

Crimp Height

GENERAL TOLERANCE	
6 MAX.	±0.2
6 OVER MAX. 30	±0.3
30 OVER MAX. 120	±0.5
ANGLE	±2°

DESIGN'D BY	DATE	Interconnect and Packaging Electronics TOKYO, JAPAN									
CHK'D BY	DATE										
APP'D BY	DATE										
REV	ECN	BY	DATE	APP	TITLE	SCALE	UNIT	DWG. No.	SHEET	REV.	
REV. RECORD					CUSTOMER COPY	PROJECTION	-/-	mm	20278	2/3	9C
SERIES No. 2814											

Notes

1. Material
 (1) Housing : PBT , UL94V-0 , black
 (2) Contact
 phosphor bronze
 gold plating
 (3) Ground contact
 phosphor bronze , gold plating
 2. Packing : reel
 3. Mating partner part No.
 : 20279-001E-01

1. 材 料
 (1) ハウジング:PBT, UL94V-0, 黒色
 (2) コンタクト
 :りん青銅
 :金メッキ
 (3) グランドコンタクト
 :りん青銅, 金メッキ
 2. 梱包 : リール
 3. かん合相手 part No.
 : 20279-001E-01

4. Permissible load of cable at mating

コネクタかん合後のケーブルに対する荷重

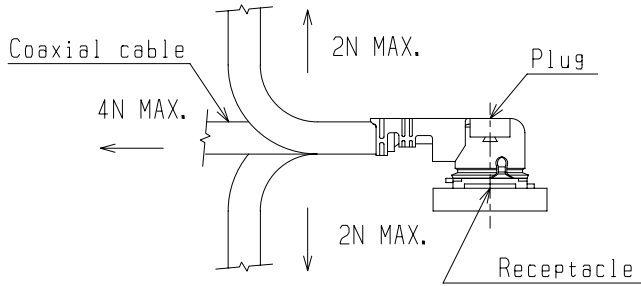

5. Suggestions for mating & unmating operation.

5. コネクタかん合時および抜去時の注意

5-1 Mating.

Please mate the connector straightly to vertical direction as much as possible, adjusting the mating axis of plug and receptacle. As excessive slant angle mating may break the connector , please don't do it.

5-1 コネクタ挿入時

PlugとReceptacleのかん合軸を合わせ、できるだけ垂直に挿入して下さい。極端な斜め挿入は行わないで下さい。コネクタ破損の原因となりますので、過度なこじり挿抜は行わないで下さい。

5-2 Unmating.

5-2 コネクタ抜去時

(1) In case of unmating by pulling tool.
 Please use the pulling tool as the following drawing, and please pull plug to vertical direction as directly as possible.

(1) 抜去ジグを用いる場合
 下図のようにできるだけ垂直に引き抜いて下さい。

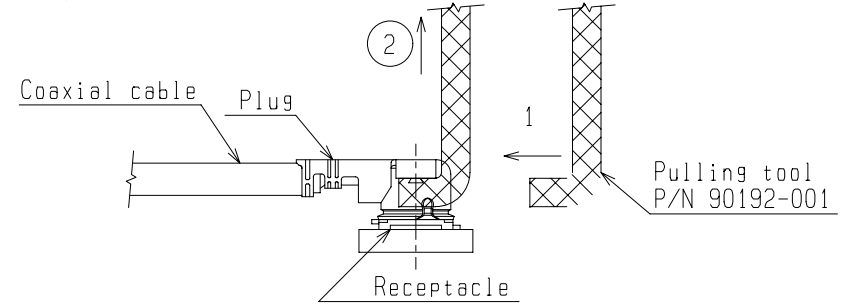

(2) In case of unmating directly by hand
 Please catch the catching area of plug , and please pull plug to vertical direction as directly as possible.

(2) 手で直接引き抜く場合
 下図の保持部をつかみ、できるだけ垂直に引き抜いて下さい。

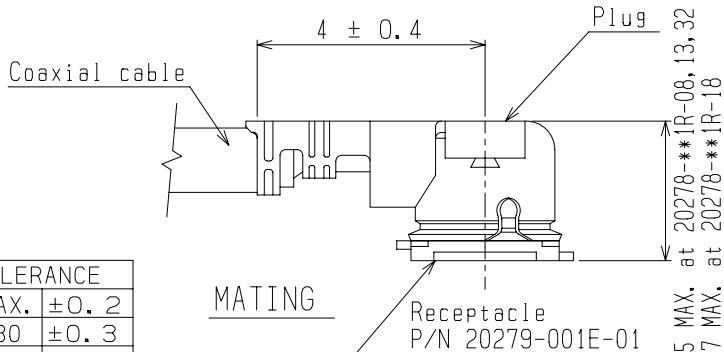
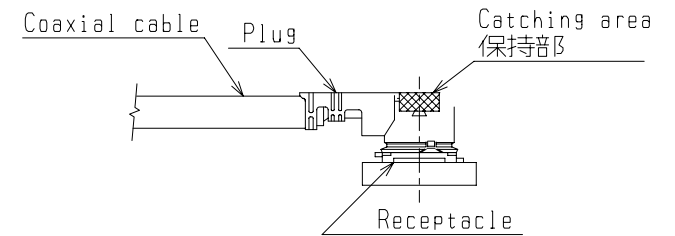

GENERAL TOLERANCE	
6 MAX.	±0.2
6 OVER MAX. 30	±0.3
30 OVER MAX. 120	±0.5
ANGLE	±2°

DESIGN' D BY	DATE	Interconnect and Packaging Electronics TOKYO, JAPAN						
CHK' D BY	DATE							
APP' D BY	DATE							
REV. RECORD	CUSTOMER COPY	PROJECTION	TITLE	SCALE	UNIT	DWG. No.	SHEET	REV.
SERIES No.	2814	①	MHF series micro coaxial connector plug vertical (ground contact : gold plating)	-/-	mm	20278	3/3	9C

PRODUCT SPECIFICATION

製品規格

No. PRS-1176

MHF series micro coaxial connector

Qualification Test Report No. TR-1021

					Prepared by	Reviewed by	Approved by
1	S1053	K.O	Nov/14/'01	K.K	K.Ohbayashi	E,Kawabe	K.Katabuchi
0	S1025	K.O	Jun/25/'01				
REV.	ECN	BY	DATE	APP.	JUN / 25 / 01	Jun / 25 / 01	Jun / 29 / 01
REVISION RECORD							

DOCUMENT CLASSIFICATION	TITLE	No.
Product Specification 製品規格	MHF series micro coaxial connector	PRS-1176
<p>1. Scope / 序言 MHF series micro coaxial connector is a wire to board connector for AWG#36,32,30 coaxial cable . MHF series micro coaxial connector は、AWG # 36,32,30同軸ケーブルの基板対ワイヤーコネクタである。</p> <p>2. Objectives / 目的 This specification covers the requirements for product performance and test methods of MHF series microcoaxial connector 本規格は、MHF series micro coaxial connector の性能と試験条件について規定する。</p> <p>3. Part No. , construction , material and finish / 構成、材料及び仕上げ (1) Part No. Plug : 20278-001R-08,-13,-18 , Receptacle : 20279-001E-01 (2) Construction, material and finish of the connector are covered as each drawings. 構成、材料及び仕上げは、各図面に指定されている通りとする。</p> <p>4. Applicable cable / 適合ケーブル 4-1 Part No. 20278-001R-08 (1) Description Inner conductor : AWG#36(7/0.05) Silver plating annealed copper wire or silver plating tin-copper alloy Dielectric core : Fluoro-plastics ,diameter 0.4(+0.04,-0.02)mm , nominal thickness 0.125mm Outer conductor : 8/5/0.05 , nominal diameter 0.65mm , silver plating annealed copper wire Jacket : Fluoro-plastics , diameter 0.81(+0.04,-0.02)mm , nominal thickness 0.08mm (2) Requirements Characteristic impedance : 50(+3,-3)ohm by TDR method (raise time 40ps) Nominal capacitance: 96 pF/m Conductor resistance of inner conductor at 293K (20°C) : 1400 ohm/km MAX. Insulation resistance : 1000 mega-ohm.km MIN. Dielectric withstand voltage : no breakdown at AC1000V for 1 minutes.</p> <p>(1) 構成 中心導体 : AWG # 36 (7 / 0.05), 銀メッキ軟銅線または銀メッキすず入り銅線 誘電体 : フッ素樹脂, 外径0.4 (+0.04, -0.02), 標準厚さ0.125mm 外部導体 : 8 / 5 / 0.05, 標準外径0.65mm, 銀メッキ軟銅線 ジャケット : フッ素樹脂, 外径0.81 (+0.04, -0.02)mm, 標準厚さ0.08mm</p> <p>(2) 仕様 特性インピーダンス : 50 ± 3 Ω (TDR, ライズタイム40ps) 標準静電容量 : 96pF / m 293K (20°C) 時の中心導体導体抵抗 : 1400 Ω / km以下 絶縁抵抗 : 1000MΩ · km以上 耐電圧 : AC1000V · 1分間にて絶縁破壊の無い事</p> <p>4-2 Part No. 20278-001R-13 (1) Description Inner conductor : AWG#32(7/0.08) Silver plating annealed copper wire or silver plating tin-copper alloy Dielectric core : Fluoro-plastics , diameter 0.68(+0.04,-0.02)mm , nominal thickness 0.22mm Outer conductor : 16/4/0.05 , nominal diameter 0.93mm , silver plating annealed copper wire Jacket : Fluoro-plastics , diameter 1.13(+0.08,-0.05)mm , nominal thickness 0.1mm</p>		

DOCUMENT CLASSIFICATION	TITLE	No.
Product Specification 製品規格	MHF series micro coaxial connector	PRS-1176
<p>(2) Requirements Characteristic impedance : 50(+2,-2)ohm by TDR method (raise time 40ps) Nominal capacitance: 97 pF/m Conductor resistance of inner conductor at 293K (20°C) : 520 ohm/km MAX. Insulation resistance : 1500 mega-ohm.km MIN. Dielectric withstand voltage : no breakdown at AC1000V for 1 minutes.</p> <p>(1) 構成 中心導体 : AWG # 32(7/0.08),銀メッキ軟銅線または銀メッキすず入り銅線 誘電体 : フッ素樹脂,外径0.68(+0.04,-0.02),標準厚さ0.22mm 外部導体 : 16/4/0.05,標準外径0.93mm, 銀メッキ軟銅線 ジャケット : フッ素樹脂,外径1.13(+0.08,-0.05)mm, 標準厚さ0.1mm</p> <p>(2) 仕様 特性インピーダンス : $50 \pm 2 \Omega$ (TDR,ライズタイム40ps) 標準静電容量 : 97pF/m 293K(20°C)時の中心導体導体抵抗 : $520 \Omega / \text{km}$以下 絶縁抵抗 : $1500M \Omega \cdot \text{km}$以上 耐電圧 : AC1000V・1分間にて絶縁破壊の無い事</p> <p>4-3 Part No. 20278-001R-32</p> <p>(1) Description Inner conductor : AWG#32(7/0.08) Silver plating annealed copper wire or silver plating tin-copper alloy Dielectric core : Fluoro-plastics , diameter 0.66(+0.05,-0.05)mm , nominal thickness 0.21mm First outer conductor : 16/5/0.05, tin plating annealed copper wire Second outer conductor : 16/6/0.05, nominal diameter 1.12mm , tin plating annealed copper wire Jacket : Fluoro-plastics , diameter 1.32(+0.1,-0.1)mm , nominal thickness 0.1mm</p> <p>(2) Requirements Characteristic impedance : 50(+2,-2)ohm by TDR method (raise time 40ps) Nominal capacitance: 95 pF/m Conductor resistance of inner conductor at 293K (20°C) : 520 ohm/km MAX. Insulation resistance : 1500 mega-ohm.km MIN. Dielectric withstand voltage : no breakdown at AC1000V for 1 minutes.</p> <p>(1) 構成 中心導体 : AWG # 32(7/0.08),銀メッキ軟銅線または銀メッキすず入り銅線 誘電体 : フッ素樹脂,外径0.66(+0.05,-0.05),標準厚さ0.21mm 外部導体(内側) : 16/5/0.05,すずメッキ軟銅線 外部導体(外側) : 16/6/0.05,標準外径1.12mm, すずメッキ軟銅線 ジャケット : フッ素樹脂,外径1.32(+0.1,-0.1)mm, 標準厚さ0.1mm</p> <p>(2) 仕様 特性インピーダンス : $50 \pm 2 \Omega$ (TDR,ライズタイム40ps) 標準静電容量 : 95pF/m 293K(20°C)時の中心導体導体抵抗 : $520 \Omega / \text{km}$以下 絶縁抵抗 : $1500M \Omega \cdot \text{km}$以上 耐電圧 : AC1000V・1分間にて絶縁破壊の無い事</p>		

DOCUMENT CLASSIFICATION	TITLE	No.
Product Specification 製品規格	MHF series micro coaxial connector	PRS-1176
<p>4-4 Part No. 20278-001R-18 RG178 B/U</p> <p>(1) Description Inner conductor : AWG#30(7/0.102) , silver plating copper clad steel wire Dielectric core : Fluoro-plastics , diameter 0.84(+0.03,-0.03)mm , nominal thickness 0.268mm Outer conductor : 16/3/0.1 , nominal diameter 1.35mm , silver plating copper wire Jacket : Fluoro-plastics , diameter 1.8(+0.1,-0.1)mm , nominal thickness 0.23mm</p> <p>(2) Requirements Characteristic impedance : 50(+2,-2)ohm by TDR method (raise time 40ps) Nominal capacitance: 95 pF/m Conductor resistance of inner conductor at 293K (20°C) : 805 ohm/km MAX. Insulation resistance : 1500 mega-ohm.km MIN. Dielectric withstand voltage : no breakdown at AC2000V for 1 minutes.</p> <p>(1) 構成 中心導体 : AWG # 30 (7 / 0. 102) , 銀メッキ銅被鋼線 誘電体 : フッ素樹脂, 外径0. 84 (±0. 03) , 標準厚さ0. 268mm 外部導体 : 16 / 3 / 0. 1, 標準外径1. 35mm, 銀メッキ軟銅線 ジャケット : フッ素樹脂, 外径1. 8 (±0. 1) mm, 標準厚さ0. 23mm</p> <p>(2) 仕様 特性インピーダンス : 50 ± 2 Ω (TDR, ライズタイム40ps) 標準静電容量 : 95pF / m 293K (20°C) 時の中心導体導体抵抗 : 805 Ω / km以下 絶縁抵抗 : 1500MΩ · km以上 耐電圧 : AC2000V · 1分間にて絶縁破壊の無い事</p> <p>5. Ratings / 定格 (1) Rated voltage / 電圧 : AC60Vrms (2) Nominal characteristic impedance / 公称特性インピーダンス : 50 Ω (3) Frequency / 周波数 : DC ~ 3GHz (4) VSWR : 1. 3 MAX. (5) Service Temperature / 使用温度範囲 : 233 ~ 363K (-40 ~ +90°C)</p> <p>6. Test methods and performance / 試験及び性能</p> <p>6-1 Test condition / 試験条件 Unless otherwise specified, all tests and measurements shall be performed under the following conditions in accordance with MIL-STD-202 全ての測定と試験は、MIL-STD-202 に基づき以下の条件で行う。 Temperature / 温度 : 288 ~ 308K (15 ~ 35°C) Humidity / 湿度 : 45 ~ 75%RH</p>		

DOCUMENT CLASSIFICATION	TITLE	No.
Product Specification 製品規格	MHF series micro coaxial connector	PRS-1176

6-2 Sample quantity / 試料数

- (1) Insulation resistance / 絶縁抵抗 : 10pcs.
- (2) Dielectric withstanding voltage / 耐電圧 : 10pcs.
- (3) VSWR : 5pcs.
- (4) Mating & unmating force / 挿抜力 : 10pcs
- (5) Durability / 耐久性 : 10pcs.
- (6) Cable retention force / ケーブル保持力 : 10pcs.
- (7) Vibration / 振動 : 10pcs.
- (8) Shock / 衝撃 : 10pcs.
- (9) Thermal shock / 温度サイクル : 10pcs.
- (10) Humidity / 湿度 : 10pcs.
- (11) Salt water spray / 塩水噴霧 : 10pcs.
- (12) Solderability / 半田付け性 : 10pcs.
- (13) Reflow soldering heat resistance / 半田耐熱性 : 10pcs.

6-3-1 Electrical / 電氣的性能

(1) Contact Resistance / 接触抵抗

- A. Testing: Solder the receptacle connector to the test board and mate the plug connector together, then measure the contact resistance as shown in Fig.1 by the four terminal method. Apply the low level condition in accordance with MIL-STD-202, Method 307.
- Open circuit voltage : 20mV MAX
 Circuit current : 10mA MAX. (DC or AC1kHz)
 Contact resistance of inner contact : <resistance of A-E> - <resistance of B-E>
 Contact resistance of ground contact : <resistance of A-D> - <resistance of B-D>

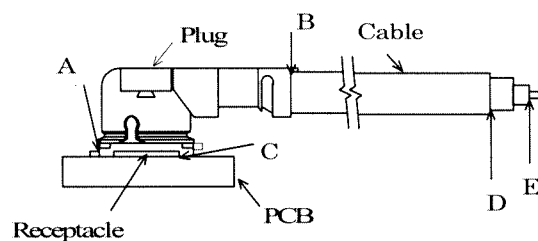

Fig.1

B. Requirements :

- Contact resistance of inner contact initial 20 milli-ohm MAX. after testing 25milli-ohm MAX.
 Contact resistance of ground contact initial 10 milli-ohm MAX. after testing 15milli-ohm MAX.

- A. 試験法: テスト基板にリセプタクルコネクタを半田付けし、プラグコネクタと嵌合させ、Fig. 1のように4端子法にて下記の条件で測定する。MIL-STD-202 試験法 307 に準拠。
 開回路電圧: 20mV以下
 試験電流 : 10mA (DCもしくはAC1kHz)
 中心導体 : <A-E間の電気抵抗> - <B-E間の電気抵抗>
 外部導体 : <A-D間の電気抵抗> - <B-D間の電気抵抗>
- B. 必要条件: 中心導体 初期 20mΩ 以下, 試験後 25mΩ 以下
 外部導体 初期 10mΩ 以下, 試験後 15mΩ 以下

DOCUMENT CLASSIFICATION Product Specification 製品規格	TITLE MHF series micro coaxial connector	No. PRS-1176
--	--	-----------------

(2) Insulation resistance / 絶縁抵抗

A. Testing : Mate the plug and receptacle connector together, then apply DC 100 V between the inner contact and the ground contact in accordance with MIL-STD-202, Method 302.

B.Requirements : Initial 500 Mohm MIN. after testing 100 Mohm MIN.

A.試験法: リセプタクル及びプラグコネクタを互いに嵌合させ、中心導体と外部導体の間に DC 100Vを印加し、測定する。MIL-STD-202 試験法 302 に準拠。

B.必要条件: 初期 500MΩ 以上 試験後 100MΩ 以上

(3) Dielectric withstanding voltage / 耐電圧

A. Testing : Mate the receptacle and plug connector together, then apply AC 200 Vrms between the inner contact and the ground contact for a minute in accordance with MIL-STD-202, Method 301.

B.Requirements : No creeping discharge, flashover, nor insulator breakdown shall occur.

A.試験法: リセプタクル及びプラグコネクタを互いに嵌合させ、中心導体と外部導体の間にAC200V(実効値)を一分間印加する。MIL-STD-202 試験法 301 に準拠。

B.必要条件: 沿面放電、空中放電、絶縁破壊等の異常のないこと。

(4) VSWR

A. Testing : Measure the VSWR as shown in Fig.3 by the network analyzer.

Frequency : 100M~3GHz

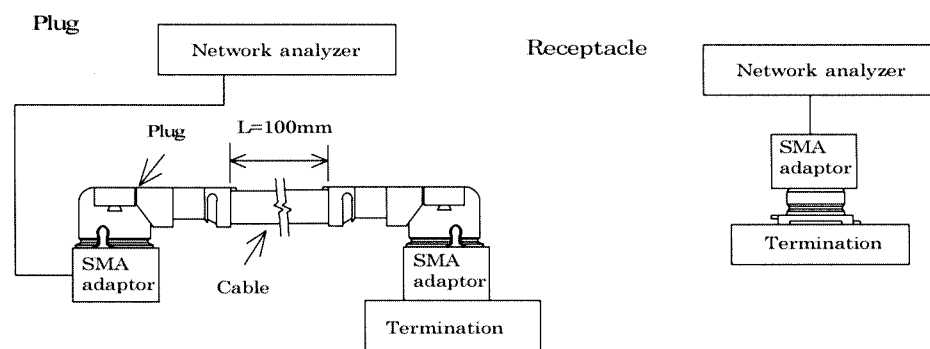

Fig.3

B.Requirements : 1.3 MAX.

A.試験法: ネットワークアナライザにて Fig.3 のようにVSWRを測定する。

周波数 : 100M~3GHz

B.必要条件: 1.3以下

6-3-2 Mechanical / 機械的性能

(1) Mating & unmating force / 挿抜力

A. Testing : Mate and unmate the receptacle connector (soldered to the test board) and plug at a speed 25 ± 3 mm/minutes along the mating by the push-on/pull-off machine .

B.Requirements :

Total mating force : Initial 20N MAX. after 30 cycles 15N MAX.

Total unmating force : Initial 5N MIN. after 30 cycles 3N MIN.

Unmating force of inner contact : Initial 0.15N MIN. after 30 cycles 0.1N MIN

DOCUMENT CLASSIFICATION Product Specification 製品規格	TITLE MHF series micro coaxial connector	No. PRS-1176
--	--	-----------------

A.試験法:挿抜試験機を用いて、基板に半田付けしたリセプタクルとプラグを嵌合軸と平行に毎分 25 ± 3 mmの速度で挿抜する。

B.必要条件:

総合挿抜力:初回挿入力 20N以下 30回後15N以下 ,初回抜去力 5N以上 ,30回後抜去力 3N以上
中心導体 :初回抜去力 0.15N以上 ,30回後抜去力 0.1N以上

(2) Durability / 耐久性

A. Testing : Mate and unmate the receptacle connector (soldered to the test board) and plug 30 cycles at a speed 25 ± 3 mm/minutes along the mating by the push-on/pull-off machine .

B.Requirements :

Contact resistance of inner contact initial 20 milli-ohm MAX. after testing 25milli-ohm MAX.

Contact resistance of ground contact initial 10 milli-ohm MAX. after testing 15milli-ohm MAX.

A.試験法:挿抜試験機を用いて、基板に半田付けしたリセプタクルとプラグを嵌合軸と平行に毎分 25 ± 3 mmの速度で30回挿抜する。

B.必要条件 中心導体接触抵抗 : 初期 20mΩ 以下, 試験後 25mΩ 以下
外部導体接触抵抗 : 初期 10mΩ 以下, 試験後 15mΩ 以下

(3) Cable retention force / ケーブル保持力

A. Testing : Apply force on the cable as shown in Fig.2.

During the testing, run 100mA DC to check electrical discontinuity.

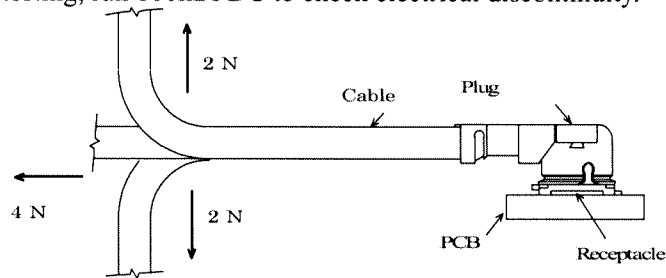

Fig.2

B.Requirements

Appearance : Looseness between the parts, chipping, breakage or other abnormality shall not occur.

Electrical discontinuity : No electrical discontinuity grater than 1 micro-sec. shall occur.

Contact resistance of inner contact initial 20 milli-ohm MAX. after testing 25milli-ohm MAX.

Contact resistance of ground contact initial 10 milli-ohm MAX. after testing 15milli-ohm MAX.

A.試験法:Fig. 2のようにケーブルに力を加える。尚、試験中にDC100mAの電流を流して電氣的瞬断を確認する。

B.必要条件 外観 : 部品のゆるみ、欠け、割れ、その他外観上の異常の無いこと。

電流瞬断 : 試験中、1 マイクロ秒を超える電氣的瞬断の無いこと。

中心導体接触抵抗 : 初期 20mΩ 以下, 試験後 25mΩ 以下

外部導体接触抵抗 : 初期 10mΩ 以下, 試験後 15mΩ 以下

DOCUMENT CLASSIFICATION	TITLE	No.
Product Specification 製品規格	MHF series micro coaxial connector	PRS-1176
<p>(4) Vibration / 振動</p> <p>A. Testing : Apply the following vibration to the mating connector . During the testing, run 100mA DC to check electrical discontinuity. Frequency : 10Hz → 100Hz → 10Hz / approx 15 minutes. Half amplitude ,Peak value of acceleration: 1.5mm or 59m/s² (6G) Directions , cycle : 3 mutually perpendicular direction , 5 cycles(approx 75min)about each direction</p> <p>B.Requirements Appearance : Looseness between the parts, chipping, breakage or other abnormality shall not occur. Electrical discontinuity : No electrical discontinuity grater than 1micro-sec. shall occur. Contact resistance of inner contact initial 20 milli-ohm MAX. after testing 25milli-ohm MAX. Contact resistance of ground contact initial 10 milli-ohm MAX. after testing 15milli-ohm MAX.</p> <p>A.試験法: 嵌合状態のコネクタを、下記の振動を加える。尚、試験中にDC100mAの電流を流して電氣的瞬断を確認する。 周波数 : 10Hz→100Hz→10Hz / 約15分間 片振幅,加速度: 1.5mm or 59m/s² (6G) 方向,サイクル: 3つの互いに直角な方向について各5サイクル(約75分)実施</p> <p>B.必要条件 外観 : 部品のゆるみ、欠け、割れ、その他外観上の異常の無いこと。 電流瞬断 : 試験中、1 マイクロ秒を超える電氣的瞬断の無いこと。 中心導体接触抵抗 : 初期 20mΩ 以下、試験後 25mΩ 以下 外部導体接触抵抗 : 初期 10mΩ 以下、試験後 15mΩ 以下</p> <p>(5) Shock / 衝撃</p> <p>A. Testing : Apply the following vibration to the mating connector in accordance with MIL-STD-202, Method 213, Condition B. During the testing, run 100mA DC to check electrical discontinuity. Peak value of acceleration: 735m/s² (75G) Duration : 11msec Wave Form : half sinusoidal Directions , cycle : 6 mutually perpendicular direction , 3 cycles about each direction</p> <p>B.Requirements Appearance : Looseness between the parts, chipping, breakage or other abnormality shall not occur. Electrical discontinuity : No electrical discontinuity grater than 1 micro-sec. shall occur. Contact resistance of inner contact initial 20 milli-ohm MAX. after testing 25milli-ohm MAX. Contact resistance of ground contact initial 10 milli-ohm MAX. after testing 15milli-ohm MAX.</p> <p>A.試験法: 嵌合状態のコネクタを、衝撃試験機に取り付け、下記の衝撃を加える。尚、試験中にDC100mAの電流を流して電氣的瞬断を確認する。MIN-STD-202 試験法 213 試験条件 B に準拠。 最大加速度: 735m/s² (75G) 標準持続時間: 11msec. 波形: 半波正弦波 方向: 直交する6方向、各3回</p> <p>B.必要条件 外観 : 部品のゆるみ、欠け、割れ、その他外観上の異常の無いこと。 電流瞬断 : 試験中、1 マイクロ秒を超える電氣的瞬断の無いこと。 中心導体接触抵抗 : 初期 20mΩ 以下、試験後 25mΩ 以下 外部導体接触抵抗 : 初期 10mΩ 以下、試験後 15mΩ 以下</p>		

DOCUMENT CLASSIFICATION	TITLE	No.
Product Specification 製品規格	MHF series micro coaxial connector	PRS-1176
<p>6-3-3 Environmental / 耐環境性</p> <p>(1) Thermal shock/ 温度サイクル</p> <p>A. Testing : Apply the following environment to the mating connector .</p> <p>Temperature ,duration :233K/30minutes→278~308K/5minutes MAX.→363K/30minutes→278~308K/5minutes MAX. (-40℃) (5~35℃) (90℃) (5~35℃)</p> <p>No. of cycles : 5 cycles</p> <p>B.Requirements</p> <p>Appearance : Looseness between the parts, chipping, breakage or other abnormality shall not occur. Contact resistance of inner contact initial 20 milli-ohm MAX. after testing 25milli-ohm MAX. Contact resistance of ground contact initial 10 milli-ohm MAX. after testing 15milli-ohm MAX. Insulation resistance : initial 500 mega-ohm MIN. after testing 100 mega-ohm MIN.</p> <p>A.試験法: 嵌合状態のコネクタを、下記の雰囲気中に放置する。</p> <p>1サイクルの条件 :233K/30分→278~308K/5分以下→363K/30分→278~308K/5分以下 (-40℃) (5~35℃) (90℃) (5~35℃)</p> <p>実施サイクル :5サイクル</p> <p>B.必要条件 外観 : 部品のゆるみ、欠け、割れ、その他外観上の異常の無いこと。 中心導体接触抵抗 : 初期 20mΩ 以下, 試験後 25mΩ 以下 外部導体接触抵抗 : 初期 10mΩ 以下, 試験後 15mΩ 以下 絶縁抵抗 : 初期 500MΩ 以上 試験後 100MΩ 以上</p> <p>(2) Humidity / 湿度</p> <p>A. Testing : Apply the following environment to the mating connector in accordance with MIL-STD-202, Method 103, Condition B .</p> <p>Temperature : 313±2 K (40±2℃) Humidity : 90~95%RH Duration : 96 hours</p> <p>B.Requirements</p> <p>Appearance : Looseness between the parts, chipping, breakage or other abnormality shall not occur. Contact resistance of inner contact initial 20 milli-ohm MAX. after testing 25milli-ohm MAX. Contact resistance of ground contact initial 10 milli-ohm MAX. after testing 15milli-ohm MAX. Insulation resistance : initial 500 mega-ohm MIN. after testing 100 mega-ohm MIN.</p> <p>A.試験法: 嵌合状態のコネクタを、下記の雰囲気中に放置する。MIL-STD-202 試験法 103 条件 B に準拠。</p> <p>温度:313±2K (40±2℃) 湿度:90~95%RH 時間:96時間</p> <p>B.必要条件 外観 : 部品のゆるみ、欠け、割れ、その他外観上の異常の無いこと。 中心導体接触抵抗 : 初期 20mΩ 以下, 試験後 25mΩ 以下 外部導体接触抵抗 : 初期 10mΩ 以下, 試験後 15mΩ 以下 絶縁抵抗 : 初期 500MΩ 以上 試験後 100MΩ 以上</p> <p>(3) Salt water spray / 塩水噴霧</p> <p>A. Testing : Apply the following environment to the mating connector in accordance with MIL-STD-202, Method 101, Condition B.</p> <p>Temperature : 308±2 K (35±2℃) Salt water density by weight : 5±1% Duration : 48 hours</p> <p>B.Requirements : Appearance no abnormality adversely affecting the performance shall occur.</p>		

DOCUMENT CLASSIFICATION Product Specification 製品規格	TITLE MHF series micro coaxial connector	No. PRS-1176
--	--	-----------------

A.試験法: 嵌合状態のコネクタを、下記の雰囲気中に放置する。

温度 : $308 \pm 2\text{K}$ ($35 \pm 2^\circ\text{C}$)

塩水濃度: $5 \pm 1\%$ (重量比)

時間 : 48時間

B.必要条件 : 外観 著しい腐食の無い事。

6-3-4 Solder / 半田付け関連

(1) Solderability / 半田付け性

A. Testing : Dip the solder tine of the contact in the solder bath at $518 \pm 5(245 \pm 5^\circ\text{C})$ for 5 ± 0.5 sec.

After immersing the tine in the flux of RMA or R type for 5 to 10 seconds in accordance with MIL-STD-202, Method 208.

B.Requirements : More than 95% of the dipped surface shall be evenly wet.

A.試験法: コネクタの半田付け部を $518 \pm 5\text{K}$ ($245 \pm 5^\circ\text{C}$) の半田槽内に 5 ± 0.5 秒浸す。フラックスは、RMA 又は R 型を使用し 5~10 秒間浸すものとする。MIL-STD-202, 試験法 208 に準拠。

B.必要条件: 浸した面積の 95% 以上に半田がむらなく付着すること。

(2) Reflow soldering heat resistance / 半田耐熱性

A. Testing : Put on the receptacle connector to PCB, apply the heat 2 cycles as shown in Fig. 4

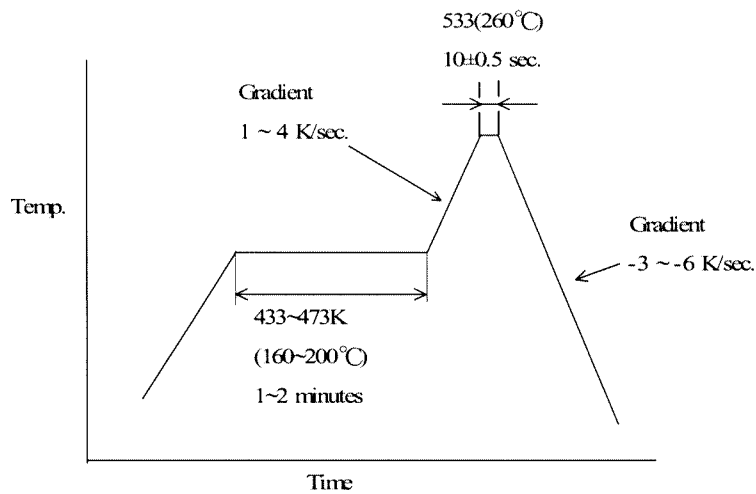

Fig.4

B.Requirements : Appearance no abnormality adversely affecting the performance shall occur.

A.試験法: 基板にリセプタクルコネクタを置き、Fig. 4の条件で2回リフローを行う。

B.必要条件: 機能を損なう変形及び欠陥の無い事。

QUALIFICATION TEST REPORT

テストレポート

No. TR-1021**MHF series micro coaxial connector****Product Specification No. PRS-1176**

					Prepared by	Reviewed by	Approved by
1	T2011	K.O	MAR/05/02	K.K	K.Ohbayashi OCT/05/01	E.Kawabe OCT/05/01	K.Katabuchi OCT/05/01
0	T1028	K.O	OCT/05/01				
REV.	ECN	BY	DATE	APP.			
REVISION RECORD							

DOCUMENT CLASSIFICATION	TITLE	No.
Qualification Test Report テストレポート	MHF series micro coaxial connector	TR-1021

1. Purpose / 目的

Testing was performed on the MHF series micro coaxial connector to determine meets the requirement of I-PEX specification, PRS-1176

MHF series micro coaxial connector の性能を製品規格 PRS-1176 に基づいて評価する。

2. Conclusion / 結論

All the specimen met the requirements of PRS-1176.

全ての試料が製品規格 (PRS-1176) の条件を満足した。

3. Sample / 試料

(1) Plug : part No.20278-001R-13

Receptacle : part No.20279-001E-01

Cable : AWG#32 coaxial cable (jacket diameter 1.13mm)

(2) Plug : part No.20278-001R-32

Receptacle : part No.20279-001E-01

Cable : AWG#32 coaxial cable (jacket diameter 1.32mm)

4. Method / 方法

Refer to product specification, PRS-1176

製品規格 (PRS-1176) 参照。

5. Results / 結果

(1) Dielectric withstanding voltage (耐電圧)

Results(結果)	No abnormality(異常無し)
Sample quantity(試料数)	10pcs.
Judge(判定)	OK

(2) VSWR

	Plug		Receptacle
	20278-001R-13	20278-001R-32	
AVE.	1.284	1.260	1.120
MAX.	1.29	1.27	1.13
MIN.	1.28	1.25	1.11
Specification(規格)	1.3 MAX.	1.3 MAX.	1.3 MAX.
Sample quantity(試料数)	5pcs.	5pcs.	5pcs.
Judge(判定)	OK	OK	OK

Plug 20278-001R-13 + AWG#32(OD1.13)

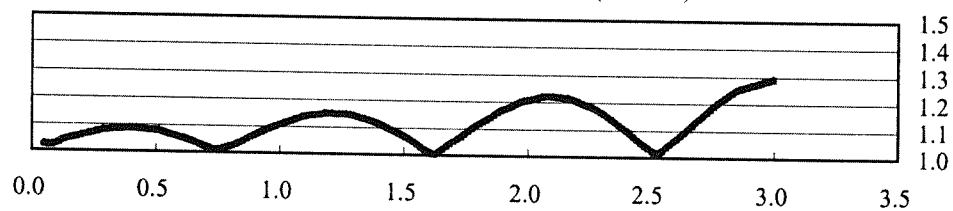

Plug 20278-001R-32 + AWG#(OD1.32)

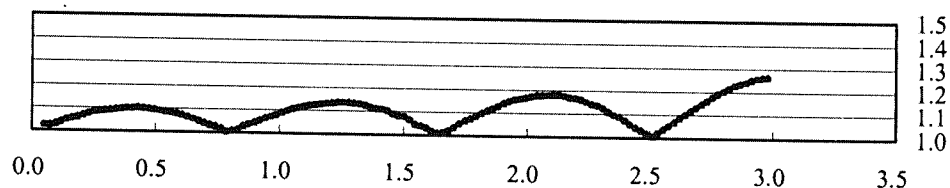

DOCUMENT CLASSIFICATION Qualification Test Report テストレポート	TITLE MHF series micro coaxial connector	No. TR-1021
---	---	----------------

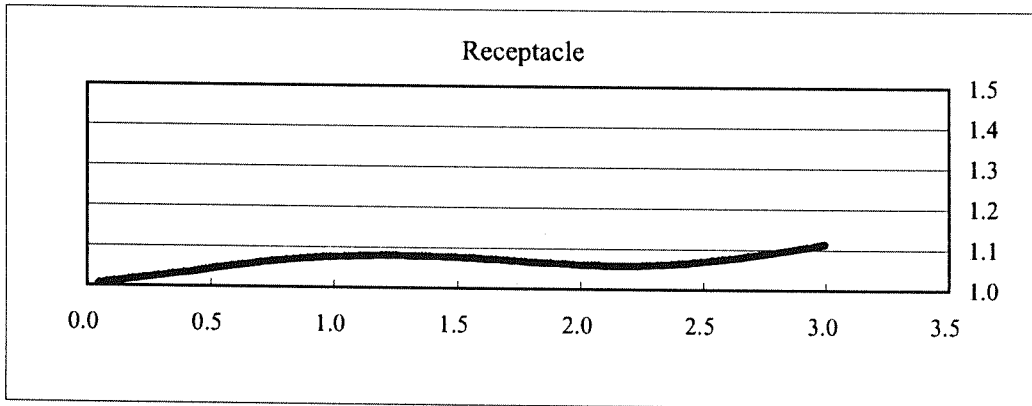

(3) Mating & unmating force(挿抜力)

Total mating force (総合挿入力)	Initial (初期)	After 30cycles (30回後)
AVE.	15.3	6.5
MAX.	16	7
MIN.	15	6
S	0.5	0.4
Specification(規格)	20 MAX.	15 MAX.
Units(単位)	N	N
Sample quantity(試料数)	10pcs.	10pcs.
Judge(判定)	OK	OK

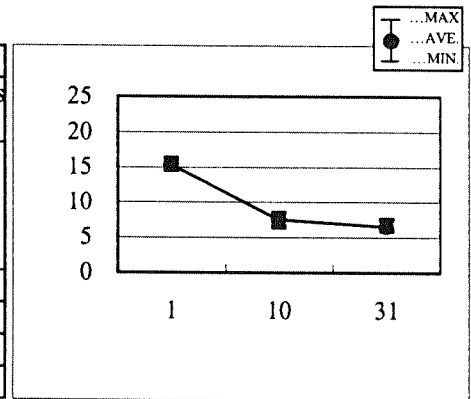

Total unmating force (総合抜去力)	Initial (初期)	After 30cycles (30回後)
AVE.	12.6	6.2
MAX.	14	7
MIN.	12	5
S	0.8	0.6
Specification(規格)	5 MIN.	3 MIN.
Units(単位)	N	N
Sample quantity(試料数)	10pcs.	10pcs.
Judge(判定)	OK	OK

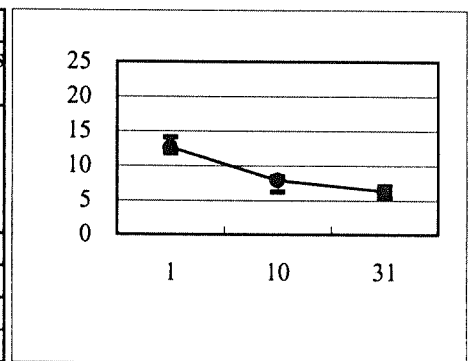

Unmating force of inner contact (中心導体抜去力)	Initial (初期)	After 30cycles (30回後)
AVE.	0.372	0.233
MAX.	0.39	0.25
MIN.	0.35	0.22
S	0.015	0.012
Specification(規格)	0.15 MIN.	0.1 MIN.
Units(単位)	N	N
Sample quantity(試料数)	10pcs.	10pcs.
Judge(判定)	OK	OK

