



FCC 47 CFR PART 15 SUBPART C

TEST REPORT

For

Tablet PC

Model: TVB00

Trade Name: FIC

Issued to

**First International Computer, Inc.
No. 300, Yang Guang St., Neihu, Taipei, Taiwan, 114**

Issued by

**Compliance Certification Services Inc.
No. 81-1, Lane 210, Pa-De 2nd Rd., Luchu Hsiang,
Taoyuan Shien, (338), Taiwan, R.O.C.
<http://www.ccsrf.com>
service@ccsrf.com**





TABLE OF CONTENTS

1. TEST RESULT CERTIFICATION.....	3
2. EUT DESCRIPTION	4
3. TEST METHODOLOGY	5
3.1 EUT CONFIGURATION	5
3.2 EUT EXERCISE.....	5
3.3 GENERAL TEST PROCEDURES.....	5
3.4 FCC PART 15.205 RESTRICTED BANDS OF OPERATIONS	6
3.5 DESCRIPTION OF TEST MODES	7
4. INSTRUMENT CALIBRATION.....	8
4.1 MEASURING INSTRUMENT CALIBRATION	8
4.2 MEASUREMENT EQUIPMENT USED	8
4.3 MEASUREMENT UNCERTAINTY	10
5. FACILITIES AND ACCREDITATIONS	11
5.1 FACILITIES	11
5.2 EQUIPMENT.....	11
5.3 TABLE OF ACCREDITATIONS AND LISTINGS.....	12
6. SETUP OF EQUIPMENT UNDER TEST	13
6.1 SETUP CONFIGURATION OF EUT.....	13
6.2 SUPPORT EQUIPMENT	13
7. FCC PART 15.247 REQUIREMENTS.....	14
7.1 20 DB BANDWIDTH.....	14
7.2 PEAK POWER.....	19
7.3 AVERAGE POWER	21
7.4 BAND EDGES MEASUREMENT	22
7.5 FREQUENCY SEPARATION	31
7.6 NUMBER OF HOPPING FREQUENCY.....	34
7.7 TIME OF OCCUPANCY (DWELL TIME)	37
7.8 SPURIOUS EMISSIONS	50
7.9 POWERLINE CONDUCTED EMISSIONS.....	66
APPENDIX I RADIO FREQUENCY EXPOSURE.....	69
APPENDIX II PHOTOGRAPHS OF TEST SETUP	70
APPENDIX 1 - PHOTOGRAPHS OF EUT	



1. TEST RESULT CERTIFICATION

Applicant: First International Computer, Inc.
No. 300, Yang Guang St., Neihu, Taipei, Taiwan, 114

Equipment Under Test: Tablet PC

Trade Name: FIC

Model: TVB00

Date of Test: September 14 ~ 24, 2010

APPLICABLE STANDARDS	
STANDARD	TEST RESULT
FCC 47 CFR Part 15 Subpart C	No non-compliance noted

We hereby certify that:

The above equipment was tested by Compliance Certification Services Inc. The test data, data evaluation, test procedures, and equipment configurations shown in this report were made in accordance with the procedures given in **ANSI C63.4: 2003** and the energy emitted by the sample EUT tested as described in this report is in compliance with the requirements of FCC Rules Part 15.207, 15.209, 15.247.

The test results of this report relate only to the tested sample EUT identified in this report.

Approved by:

Reviewed by:

Rex Lai
Section Manager
Compliance Certification Services Inc.

Gina Lo
Section Manager
Compliance Certification Services Inc.



2. EUT DESCRIPTION

Product	Tablet PC
Trade Name	FIC
Model Number	TVB00
Model Discrepancy	N/A
WIFI+BT combo card Trade Name	Azure Wave
WIFI+BT combo card Model Name	AW-NB037H
Power Supply	1. Power Adapter: DARFON / BA01-J I/P: 100-240V, 50/60Hz O/P: 19V, 2.1A 2. Battery Model: DFN-TVBXXALE2 Rating: 7.4V, 2700mAh, 19.98Wh
Frequency Range	2402 ~ 2480 MHz
Transmit Power	3.90 dBm
Modulation Technique	GFSK for 1Mbps; $\pi/4$ -DQPSK for 2Mbps; 8DPSK for 3Mbps
Number of Channels	79 Channels
Antenna Specification	Gain: 2.15 dBi
Antenna Designation	Couple Antenna

Remark:

1. The sample selected for test was production product and was provided by manufacturer.
2. This submittal(s) (test report) is intended for FCC ID: **EUN-TVB00** filing to comply with Section 15.207, 15.209 and 15.247 of the FCC Part 15, Subpart C Rules.



3. TEST METHODOLOGY

The tests documented in this report were performed in accordance with ANSI C63.4 and FCC CFR 47 Part 15.207, 15.209 and 15.247.

3.1 EUT CONFIGURATION

The EUT configuration for testing is installed on RF field strength measurement to meet the Commissions requirement and operating in a manner that intends to maximize its emission characteristics in a continuous normal application.

3.2 EUT EXERCISE

The EUT was operated in the engineering mode to fix the TX frequency that was for the purpose of the measurements.

According to its specifications, the EUT must comply with the requirements of the Section 15.207, 15.209 and 15.247 under the FCC Rules Part 15 Subpart C.

3.3 GENERAL TEST PROCEDURES

Conducted Emissions

The EUT is placed on the turntable, which is 0.8 m above ground plane. According to the requirements in Section 13.1.4.1 of ANSI C63.4 Conducted emissions from the EUT measured in the frequency range between 0.15 MHz and 30MHz using CISPR Quasi-peak and average detector modes.

Radiated Emissions

The EUT is placed on a turn table, which is 0.8 m above ground plane. The turntable shall rotate 360 degrees to determine the position of maximum emission level. EUT is set 3m away from the receiving antenna, which varied from 1m to 4m to find out the highest emission. And also, each emission was to be maximized by changing the polarization of receiving antenna both horizontal and vertical. In order to find out the maximum emissions, exploratory radiated emission measurements were made according to the requirements in Section 13.1.4.1 of ANSI C63.4.



3.4 FCC PART 15.205 RESTRICTED BANDS OF OPERATIONS

(a) Except as shown in paragraph (d) of this section, only spurious emissions are permitted in any of the frequency bands listed below:

MHz	MHz	MHz	GHz
0.090 - 0.110	16.42 - 16.423	399.9 - 410	4.5 - 5.15
¹ 0.495 - 0.505	16.69475 - 16.69525	608 - 614	5.35 - 5.46
2.1735 - 2.1905	16.80425 - 16.80475	960 - 1240	7.25 - 7.75
4.125 - 4.128	25.5 - 25.67	1300 - 1427	8.025 - 8.5
4.17725 - 4.17775	37.5 - 38.25	1435 - 1626.5	9.0 - 9.2
4.20725 - 4.20775	73 - 74.6	1645.5 - 1646.5	9.3 - 9.5
6.215 - 6.218	74.8 - 75.2	1660 - 1710	10.6 - 12.7
6.26775 - 6.26825	108 - 121.94	1718.8 - 1722.2	13.25 - 13.4
6.31175 - 6.31225	123 - 138	2200 - 2300	14.47 - 14.5
8.291 - 8.294	149.9 - 150.05	2310 - 2390	15.35 - 16.2
8.362 - 8.366	156.52475 -	2483.5 - 2500	17.7 - 21.4
8.37625 - 8.38675	156.52525	2655 - 2900	22.01 - 23.12
8.41425 - 8.41475	156.7 - 156.9	3260 - 3267	23.6 - 24.0
12.29 - 12.293	162.0125 - 167.17	3332 - 3339	31.2 - 31.8
12.51975 - 12.52025	167.72 - 173.2	3345.8 - 3358	36.43 - 36.5
12.57675 - 12.57725	240 - 285	3600 - 4400	(²)
13.36 - 13.41	322 - 335.4		

¹ Until February 1, 1999, this restricted band shall be 0.490-0.510 MHz.

² Above 38.6

(b) Except as provided in paragraphs (d) and (e), the field strength of emissions appearing within these frequency bands shall not exceed the limits shown in Section 15.209. At frequencies equal to or less than 1000 MHz, compliance with the limits in Section 15.209 shall be demonstrated using measurement instrumentation employing a CISPR quasi-peak detector. Above 1000 MHz, compliance with the emission limits in Section 15.209 shall be demonstrated based on the average value of the measured emissions. The provisions in Section 15.35 apply to these measurements.



3.5 DESCRIPTION OF TEST MODES

The EUT (model: TVB00) had been tested under operating condition.

Test program used to control the EUT for staying in continuous transmitting mode was programmed.

Software used to control the EUT for staying in continuous transmitting mode was programmed.

After verification, all tests were carried out with the worst case test modes as shown below except radiated spurious emission below 1GHz and power line conducted emissions below 30MHz, which worst case was in normal link mode only.

During the preliminary test, GFSK, $\pi/4$ -QPSK & 8DPSK with DH1 were pre-tested and found that 8DPSK emits the highest output power. Then the tests were carried on with DH1 compare to DH3 & DH5 and found that 8DPSK with DH5 emit the highest output power, and therefore had been tested under operating condition.

The field strength of spurious emission was measured in the following position: EUT stand-up position (Z axis), lie-down position (X, Y axis). The worst emission was found in stand-up position (Z axis) and the worst case was recorded.

Following channels were selected for the radiated emission testing only as listed below:

Tested Channel	Modulation Type	Packet Type	Date Rate	Axis
Low, Mid, High	GFSK	DH 5	1	Z
Low, Mid, High	8DPSK	DH 5	3	Z



4. INSTRUMENT CALIBRATION

4.1 MEASURING INSTRUMENT CALIBRATION

The measuring equipment, which was utilized in performing the tests documented herein, has been calibrated in accordance with the manufacturer's recommendations for utilizing calibration equipment, which is traceable to recognized national standards.

4.2 MEASUREMENT EQUIPMENT USED

Equipment Used for Emissions Measurement

Remark: Each piece of equipment is scheduled for calibration once a year and Loop Antenna is scheduled for calibration once three years.

Conducted Emissions Test Site				
Name of Equipment	Manufacturer	Model	Serial Number	Calibration Due
Spectrum Analyzer	Agilent	E4446A	MY43360131	03/03/2011
Power Meter	Agilent	E4416A	GB41291611	06/27/2011
Power Sensor	Agilent	E9327A	US40441097	06/27/2011

3M Semi Anechoic Chamber				
Name of Equipment	Manufacturer	Model	Serial Number	Calibration Due
Spectrum Analyzer	Agilent	E4446A	US42510252	10/26/2010
EMI Test Receiver	R&S	ESCI	100064	02/04/2011
Pre-Amplifier	Mini-Circuits	ZFL-1000LN	SF350700823	01/13/2011
Pre-Amplifier	MITEQ	AFS44-00102650-42-10P-44	1415367	11/20/2010
Bilog Antenna	Sunol Sciences	JB3	A030105	09/10/2011
Horn Antenna	EMCO	3117	00055165	12/07/2010
Loop Antenna	EMCO	6502	8905/2356	06/10/2013
Turn Table	CCS	CC-T-1F	N/A	N.C.R
Antenna Tower	CCS	CC-A-1F	N/A	N.C.R
Controller	CCS	CC-C-1F	N/A	N.C.R
Site NSA	CCS	N/A	N/A	12/31/2010
Test S/W	EZ-EMC (CCS-3A1RE)			



Powerline Conducted Emissions Test Site				
Name of Equipment	Manufacturer	Model	Serial Number	Calibration Due
TEST RECEIVER	R&S	ESCI	100234	06/13/2011
LISN (EUT)	FCC	FCC-LISN-50-32-2	08009	03/25/2011
LISN	EMCO	3825/2	1382	01/11/2011
BNC CABLE	MIYAZAKI	5D-FB	BNC B3	08/10/2011
Pulse Limiter	R&S	ESH3-Z2	100374	08/19/2011
THERMO-HYGRO METER	TOP	HA-202	9303-3	01/31/2011
Test S/W	EZ-EMC			



4.3 MEASUREMENT UNCERTAINTY

PARAMETER	UNCERTAINTY
Powerline Conducted Emission	+/- 1.6202
3M Semi Anechoic Chamber / 30M~200M	+/- 4.0606
3M Semi Anechoic Chamber / 200M~1000M	+/- 3.9979
3M Semi Anechoic Chamber / 1G~8G	+/- 2.5790
3M Semi Anechoic Chamber / 8G~18G	+/- 2.5928
3M Semi Anechoic Chamber / 18G~26G	+/- 2.7212
3M Semi Anechoic Chamber / 26G~40G	+/- 2.9520

Remark: This uncertainty represents an expanded uncertainty expressed at approximately the 95% confidence level using a coverage factor of $k=2$.



5. FACILITIES AND ACCREDITATIONS

5.1 FACILITIES

All measurement facilities used to collect the measurement data are located at

No.199, Chunghsen Road, Hsintien City, Taipei Hsien, Taiwan, R.O.C.

Tel: 886-2-2217-0894 / Fax: 886-2-2217-1029

Remark: The powerline conducted emissions test items was tested at Compliance Certification Services Inc. (Hsintien Lab.) The test equipments were listed in page 10 and the test data, please refer page 67-68.

No.11, Wugong 6th Rd., Wugu Industrial Park, Taipei Hsien 248, Taiwan

Tel: 886-2-2299-9720 / Fax: 886-2-2298-4045

No.81-1, Lane 210, Bade 2nd Rd., Luchu Hsiang, Taoyuan Hsien 338, Taiwan

Tel: 886-3-324-0332 / Fax: 886-3-324-5235

The sites are constructed in conformance with the requirements of ANSI C63.7, ANSI C63.4 and CISPR Publication 22.

5.2 EQUIPMENT

Radiated emissions are measured with one or more of the following types of linearly polarized antennas: tuned dipole, biconical, log periodic, bi-log, and/or ridged waveguide, horn. Spectrum analyzers with pre-selectors and quasi-peak detectors are used to perform radiated measurements.



Conducted emissions are measured with Line Impedance Stabilization Networks and EMI Test Receivers.

Calibrated wideband preamplifiers, coaxial cables, and coaxial attenuators are also used for making measurements.

All receiving equipment conforms to CISPR Publication 16-1, "Radio Interference Measuring Apparatus and Measurement Methods."



5.3 TABLE OF ACCREDITATIONS AND LISTINGS

Country	Agency	Scope of Accreditation	Logo
USA	A2LA	CFR 47, FCC Part15/18, CISPR 22, EN 55022, ICES-003, AS/NZS CISPR 22, VCCI V-3, EN 55011, CISPR 11, IEC/EN 61000-4-2/3/4/5/6/8/11, EN 61000-6-1/2/3/4, EN 55024, CISPR 24, AS/NZS CISPR 24, AS/NZS 61000.6.2, EN 55014-1/-2, ETSI EN 300 386 v1.3.2/v1.3.3, IEC/EN 61000-3-2, AS/NZS 61000.3.2, IEC/EN 61000-3-3, AS/NZS 61000.3.3	
USA	FCC MRA	3/10 meter Open Area Test Sites to perform FCC Part 15/18 measurements	
Japan	VCCI	3/10 meter Open Area Test Sites and conducted test sites to perform radiated/conducted measurements	VCCI R-2882/2541/2798/725/1868 C-402/747/912 T-321/325
Taiwan	TAF	EN 55014-1, CISPR 14, CNS 13781-1, EN 55013, CISPR 13, CNS 13439, EN 55011, CISPR 11, CNS 13803, PLMN09, IS2045-0, LP0002 FCC Part 27/90, Part 15B/C/D/E, RSS-192/193/210/310 ETSI EN 300 328/ 300 220-1/ 300 220-2/ 301 893/ 301 489-01/ 301 489-03/ 301 489-07 / 301 489-17/ 300 440-1/ 300 440-2 AS/NZS 4268, AS/NZS 4771 CISPR 22, EN 55022, CNS 13438, AS/NZS CISPR 22, VCCI, IEC/EN 61000-4-2/3/4/5/6/8/11, CNS 14676-2/3/4/5/6/8, CNS 14934-2/3, CNS 13783-1, CNS 13439, CNS 13803	
Taiwan	BSMI	CNS 13438, CNS 13783-1, CNS 13439, CNS 14115	SL2-IS-E-0014 / IN-E-0014 /A1-E-0014 /R1-E-0014 /R2-E-0014 /L1-E-0014
Canada	Industry Canada	RSS212, Issue 1	Canada IC 2324C-3 IC 2324C-5

* No part of this report may be used to claim or imply product endorsement by A2LA or any agency of the US Government.



6. SETUP OF EQUIPMENT UNDER TEST

6.1 SETUP CONFIGURATION OF EUT

See test photographs attached in Appendix II for the actual connections between EUT and support equipment.

6.2 SUPPORT EQUIPMENT

No.	Equipment	Model No.	Serial No.	FCC ID / BSMI ID	Trade Name	Data Cable	Power Cord
1.	USB Mouse	MOC5UO	N/A	DOC BSMI: R41108	DELL	Shielded, 1.8m	N/A
2.	Earphone & Microphone	MSB301	N/A	N/A	e-Sense	Unshielded, 2.0m	N/A
3.	Monitor	933SN+	N/A	DOC BSMI: R33475	SAMSUNG	HDMI switch D-SUB: Shielded, 1.8m with two cores	Unshielded, 1.8m
4.	USB HDD	MT601	46c1977yL102b9c340f	DOC BSMI: D33254	DELL	Shielded, 1.6m with two cores	Unshielded, 1.8m

Remark:

1. All the equipment/cables were placed in the worst-case configuration to maximize the emission during the test.
2. Grounding was established in accordance with the manufacturer's requirements and conditions for the intended use.



7. FCC PART 15.247 REQUIREMENTS

7.120 DB BANDWIDTH

LIMIT

None; for reporting purposes only.

Test Configuration

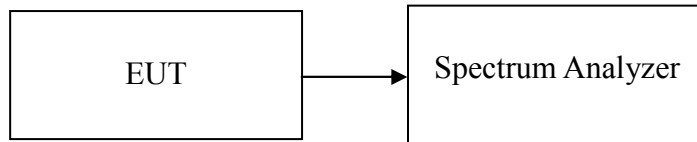

TEST PROCEDURE

1. Place the EUT on the table and set it in the transmitting mode.
2. Remove the antenna from the EUT and then connect a low loss RF cable from the antenna port to the spectrum analyzer.
3. Set the spectrum analyzer as RBW=10kHz, VBW = 30kHz, Span = 1.5MHz, Sweep = auto.
4. Mark the peak frequency and 20dB (upper and lower) frequency.
5. Repeat until all the rest channels are investigated.

TEST RESULTS

No non-compliance noted.

Test Data

For GFSK / DH5

Channel	Frequency (MHz)	20dB Bandwidth (MHz)
Low	2402	0.937
Mid	2441	0.930
High	2480	0.930

For 8DPSK / DH5

Channel	Frequency (MHz)	20dB Bandwidth (MHz)
Low	2402	1.295
Mid	2441	1.295
High	2480	1.300



Test Plot

For GFSK / DH5

20dB Bandwidth (CH Low)

Agilent 11:27:47 Sep 24, 2010

R T

Δ Mkr2 937 kHz
-0.41 dB

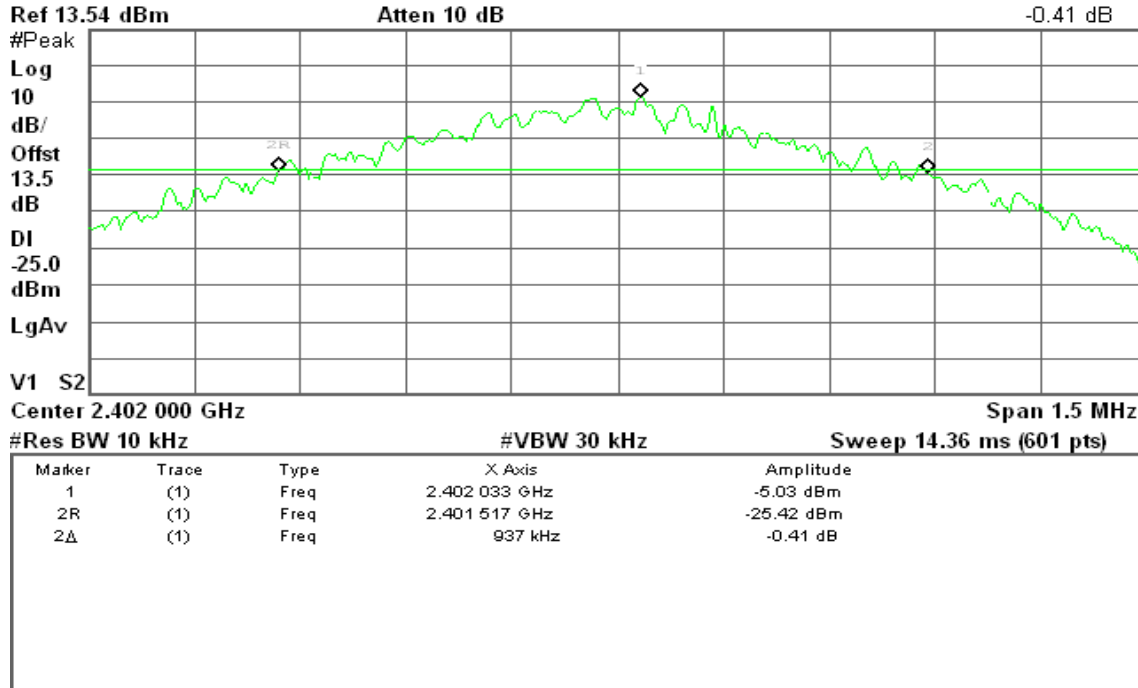

20dB Bandwidth (CH Mid)

Agilent 11:29:45 Sep 24, 2010

R T

Δ Mkr2 930 kHz
-0.32 dB

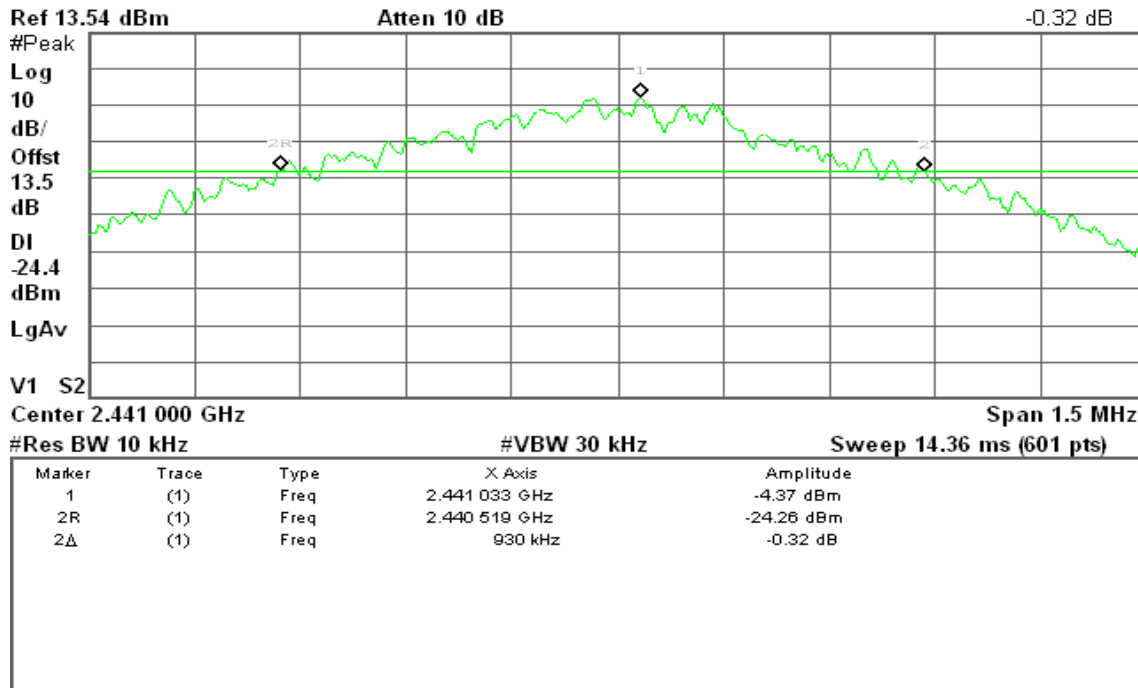



20dB Bandwidth (CH High)

Agilent 11:31:01 Sep 24, 2010

R T

Δ Mkr2 930 kHz
-0.53 dB

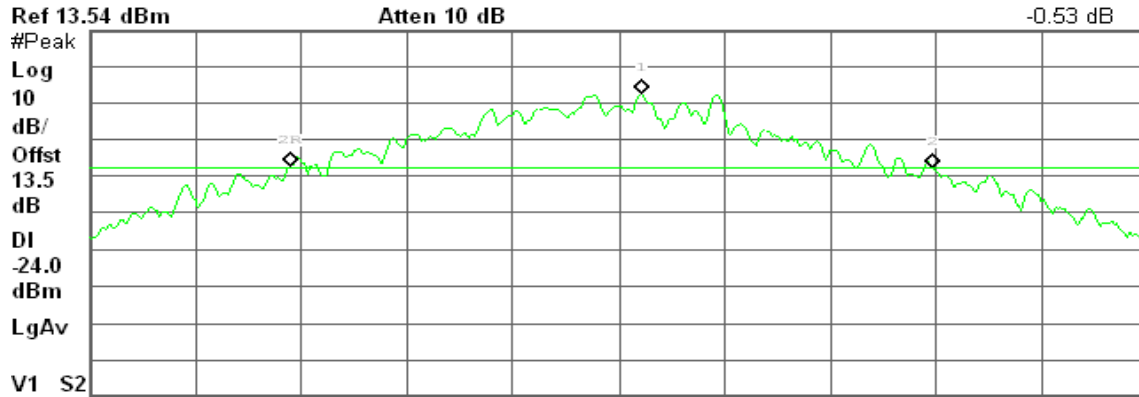

Center 2.480 000 GHz

Span 1.5 MHz

#Res BW 10 kHz

#VBW 30 kHz

Sweep 14.36 ms (601 pts)

Marker	Trace	Type	X Axis	Amplitude
1	(1)	Freq	2.480 033 GHz	-3.96 dBm
2R	(1)	Freq	2.479 519 GHz	-23.60 dBm
2Δ	(1)	Freq	930 kHz	-0.53 dB



For 8DPSK / DH5

20dB Bandwidth (CH Low)

Agilent 15:03:37 Sep 24, 2010

R T

Δ Mkr2 1.295 MHz

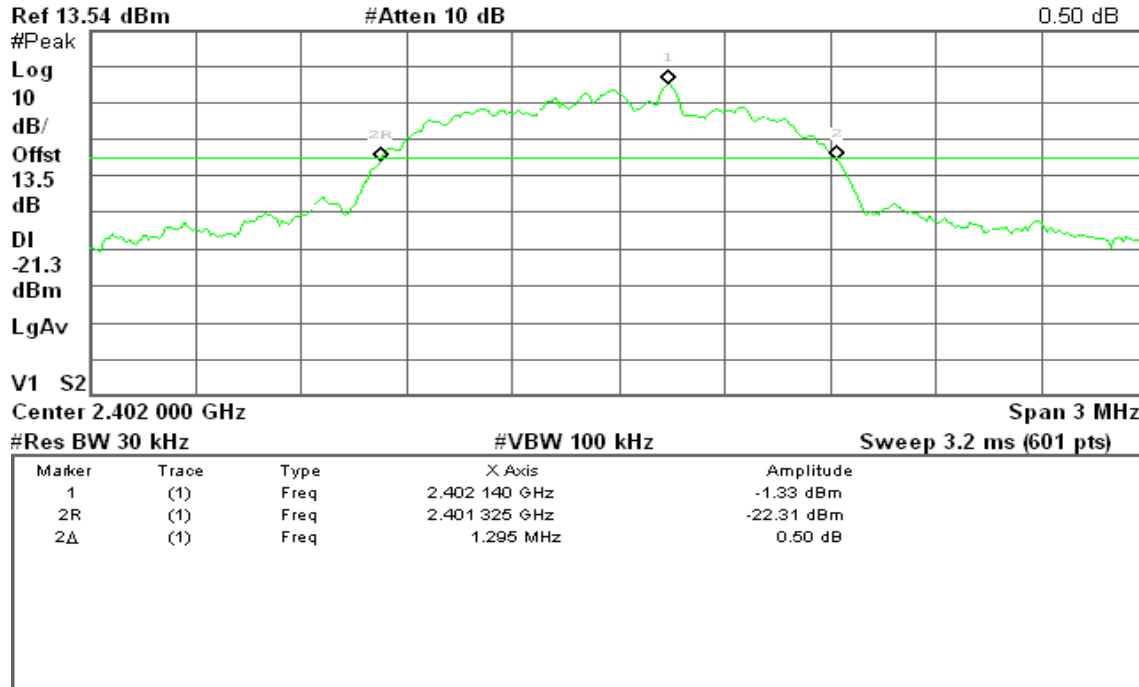

20dB Bandwidth (CH Mid)

Agilent 14:51:59 Sep 24, 2010

R T

Δ Mkr2 1.295 MHz

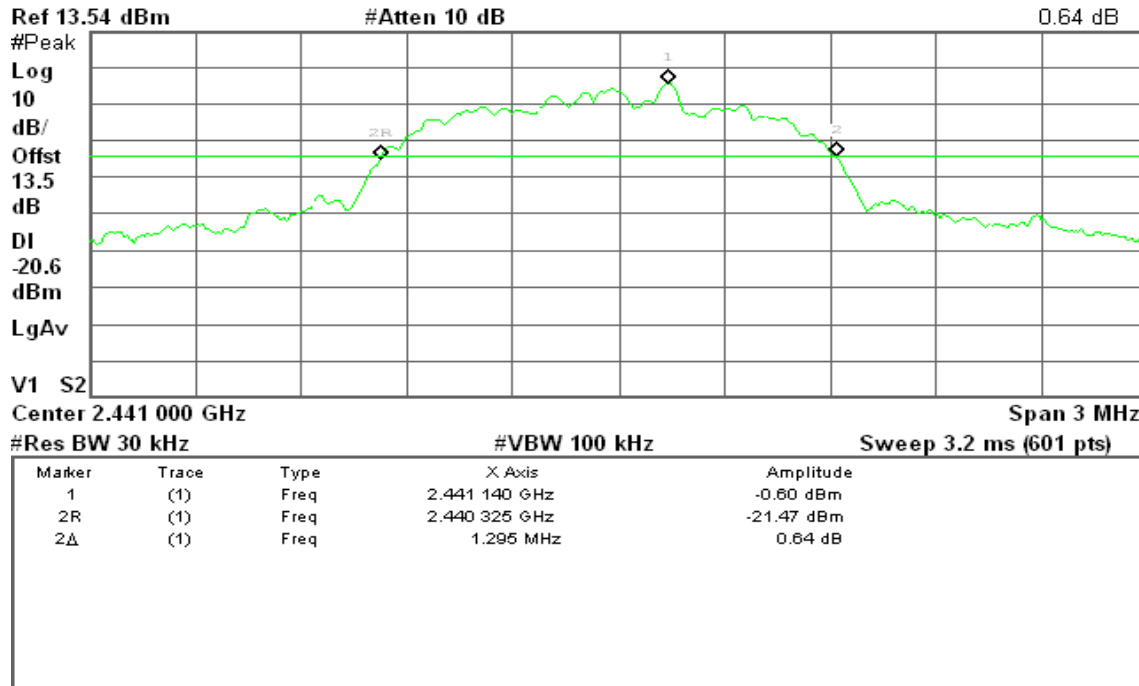



20dB Bandwidth (CH High)

Agilent 14:38:25 Sep 24, 2010

R T

Δ Mkr2 1.300 MHz
-0.37 dB

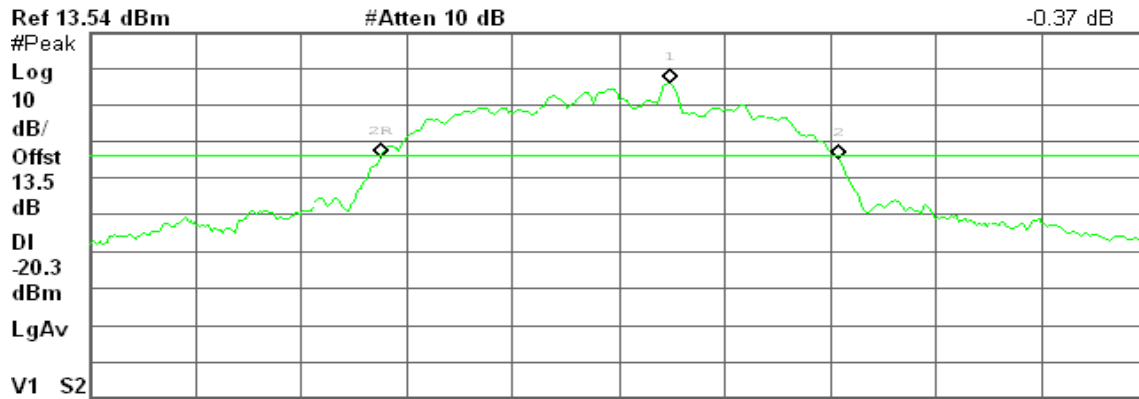

Center 2.480 000 GHz

Span 3 MHz

#Res BW 30 kHz

#VBW 100 kHz

Sweep 3.2 ms (601 pts)

Marker	Trace	Type	X Axis	Amplitude
1	(1)	Freq	2.480 145 GHz	-0.29 dBm
2R	(1)	Freq	2.479 325 GHz	-20.83 dBm
2Δ	(1)	Freq	1.300 MHz	-0.37 dB



7.2 PEAK POWER

LIMIT

The maximum peak output power of the intentional radiator shall not exceed the following:

1. According to §15.247(a)(1), Frequency hopping systems shall have hopping channel carrier frequencies separated by a minimum of 25 kHz or the 20 dB bandwidth of the hopping channel, whichever is greater. Alternatively, frequency hopping systems operating in the 2400-2483.5 MHz band may have hopping channel carrier frequencies that are separated by 25 kHz or two-thirds of the 20 dB bandwidth of the hopping channel, whichever is greater, provided the systems operate with an output power no greater than 125 mW.
2. According to §15.247(b)(3), for systems using digital modulation in the bands of 902-928 MHz, 2400-2483.5 MHz, and 5725-5850 MHz: 1 Watt.
3. According to §15.247(b)(4), the conducted output power limit specified in paragraph (b) of this section is based on the use of antennas with directional gains that do not exceed 6 dBi. Except as shown in paragraph (c) of this section, if transmitting antennas of directional gain greater than 6 dBi are used, the conducted output power from the intentional radiator shall be reduced below the stated values in paragraphs (b)(1), (b)(2), and (b)(3) of this section, as appropriate, by the amount in dB that the directional gain of the antenna exceeds 6 dBi.

Test Configuration

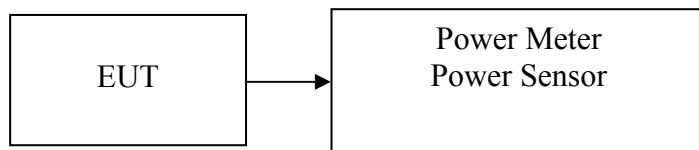

TEST PROCEDURE

The transmitter output is connected to the Power Meter. The Power Meter is set to the peak power detection.

TEST RESULTS

No non-compliance noted.



Test Data

For GFSK / DH5

Channel	Frequency (MHz)	Output Power (dBm)	Output Power (W)	Limit (W)	Result
Low	2402	1.08	0.0013	0.125	PASS
Mid	2441	1.63	0.0015		PASS
High	2480	1.96	0.0016		PASS

For 8DPSK / DH5

Channel	Frequency (MHz)	Output Power (dBm)	Output Power (W)	Limit (W)	Result
Low	2402	2.93	0.0020	0.125	PASS
Mid	2441	3.45	0.0022		PASS
High	2480	3.90	0.0025		PASS



7.3 AVERAGE POWER

LIMIT

None; for reporting purposes only.

Test Configuration

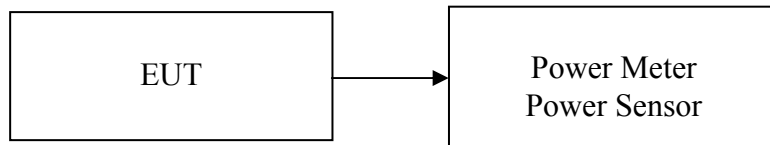

TEST PROCEDURE

The transmitter output is connected to the Power Meter. The Power Meter is set to the peak power detection.

TEST RESULTS

No non-compliance noted.

Test Data

For GFSK / DH5

Channel	Frequency (MHz)	Output Power (dBm)	Output Power (W)
Low	2402	-0.20	0.0010
Mid	2441	0.36	0.0011
High	2480	0.77	0.0012

For 8DPSK / DH5

Channel	Frequency (MHz)	Output Power (dBm)	Output Power (W)
Low	2402	-1.45	0.0007
Mid	2441	-0.91	0.0008
High	2480	-0.44	0.0009



7.4 BAND EDGES MEASUREMENT

LIMIT

According to §15.247(d), in any 100 kHz bandwidth outside the frequency bands in which the spread spectrum intentional radiator is operating, the radio frequency power that is produced by the intentional radiator shall be at least 20 dB below that in the 100 kHz bandwidth within the band that contains the highest level of the desired power, based on either an RF conducted or a radiated measurement, provided the transmitter demonstrates compliance with the peak conducted power limits. In addition, radiated emissions which fall in the restricted bands, as defined in §15.205(a), must also comply with the radiated emission limits specified in 15.209(a) (see Section 15.205(c)).

Test Configuration

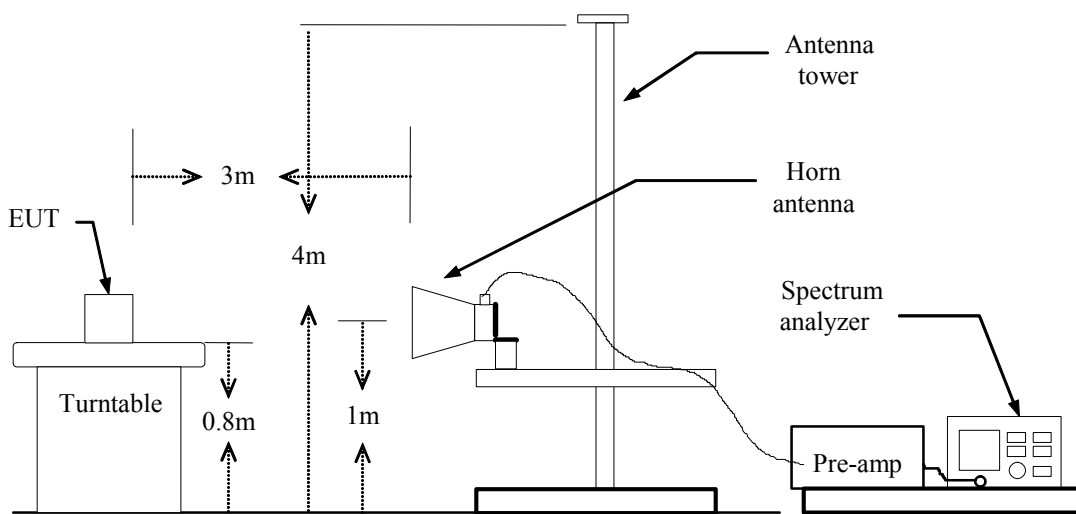

TEST PROCEDURE

1. The EUT is placed on a turntable, which is 0.8m above the ground plane.
2. The turntable shall be rotated for 360 degrees to determine the position of maximum emission level.
3. EUT is set 3m away from the receiving antenna, which is varied from 1m to 4m to find out the highest emission.
4. Set the spectrum analyzer in the following setting in order to capture the lower and upper band-edges of the emission:
 - (a) PEAK: RBW=VBW=1MHz / Sweep=AUTO
 - (b) AVERAGE: RBW=1MHz / VBW=10Hz / Sweep=AUTO
5. Repeat the procedures until all the PEAK and AVERAGE versus POLARIZATION are measured.

TEST RESULTS

Refer to attach spectrum analyzer data chart.



For GFSK / DH5

Band Edges (CH Low)

Detector mode: Peak

Polarity: Vertical

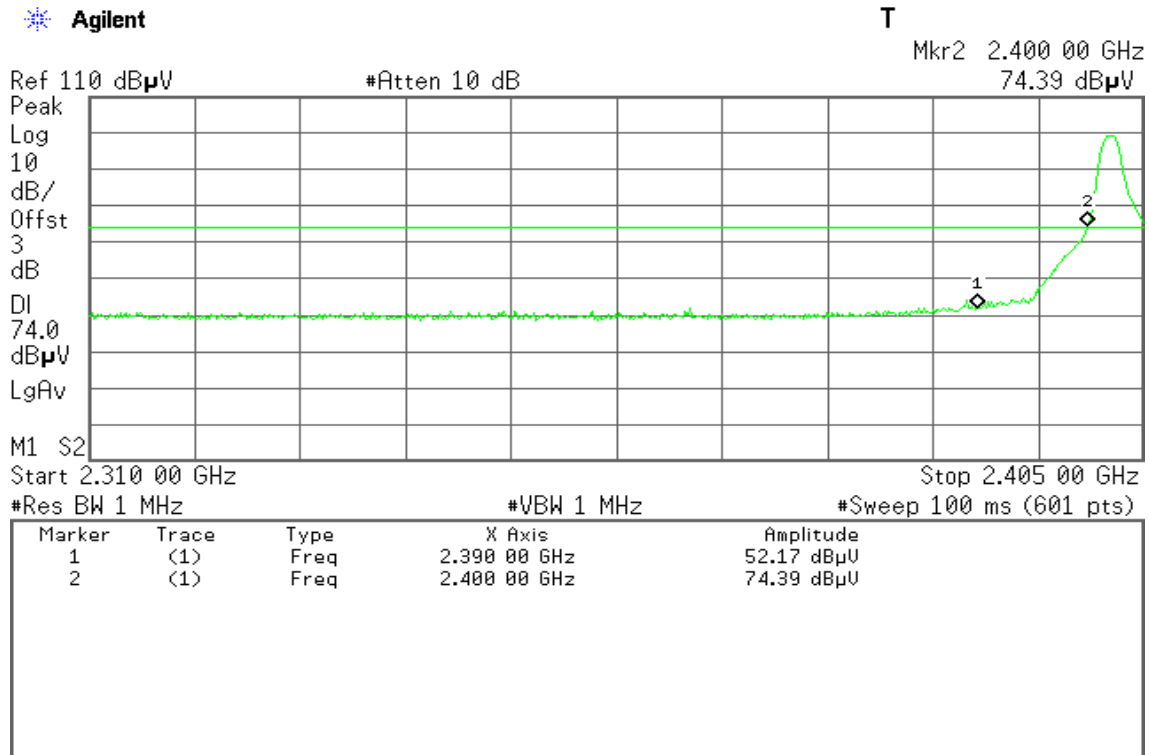

Detector mode: Average

Polarity: Vertical

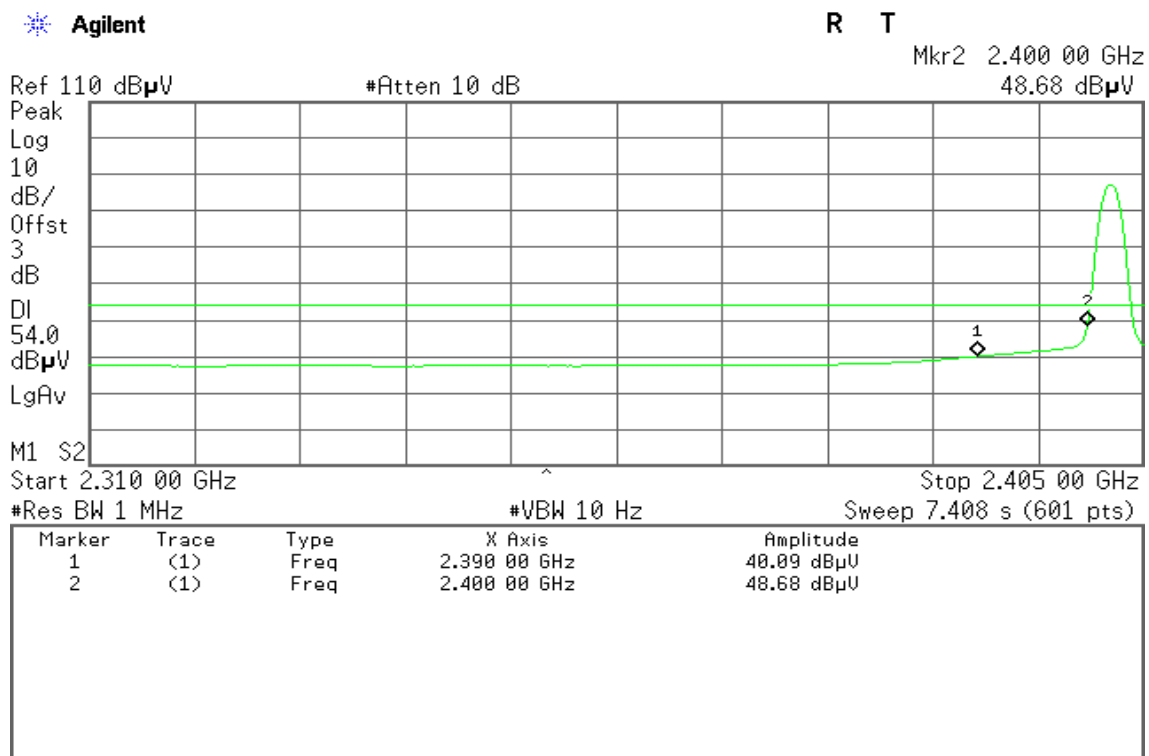



Detector mode: Peak

Polarity: Horizontal

Agilent

T

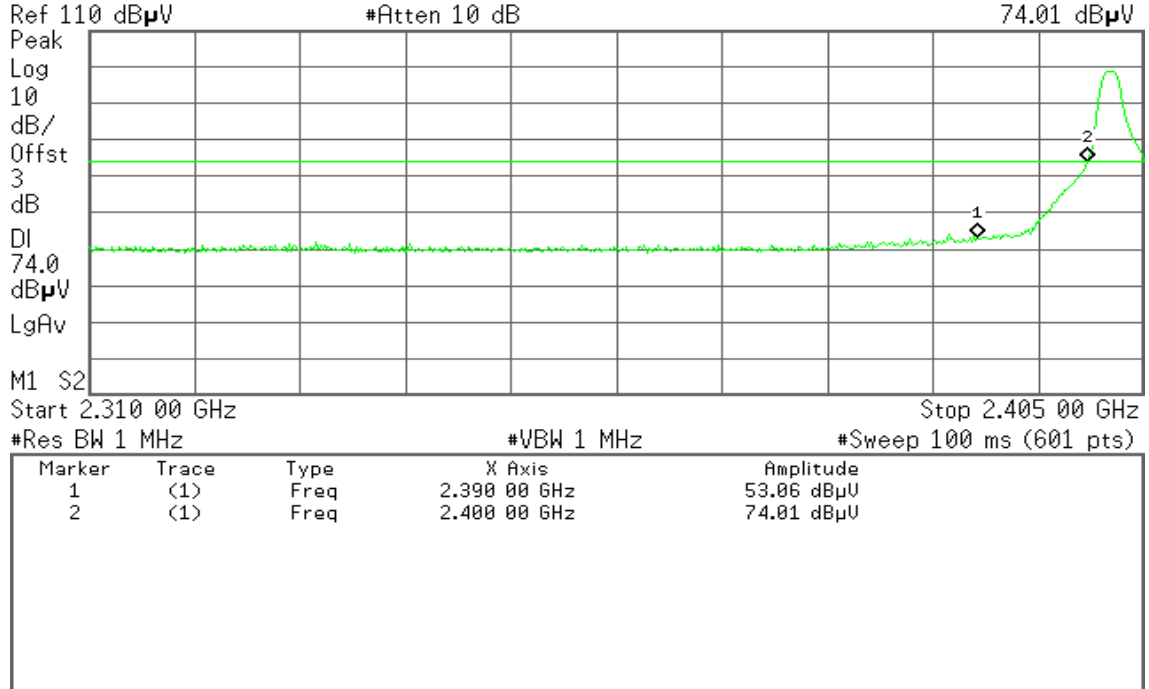

Detector mode: Average

Polarity: Horizontal

Agilent

T

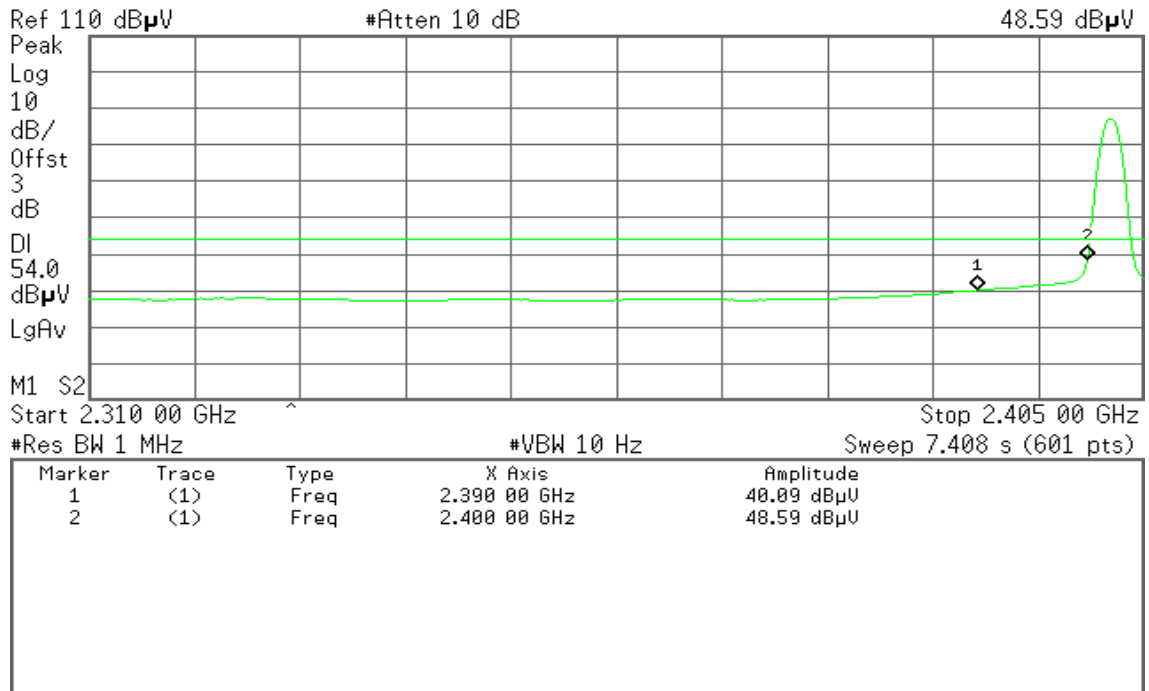



Band Edges (CH High)

Detector mode: Peak

Polarity: Vertical

Agilent

R T

Mkr1 2.483 50 GHz
71.81 dB μ V

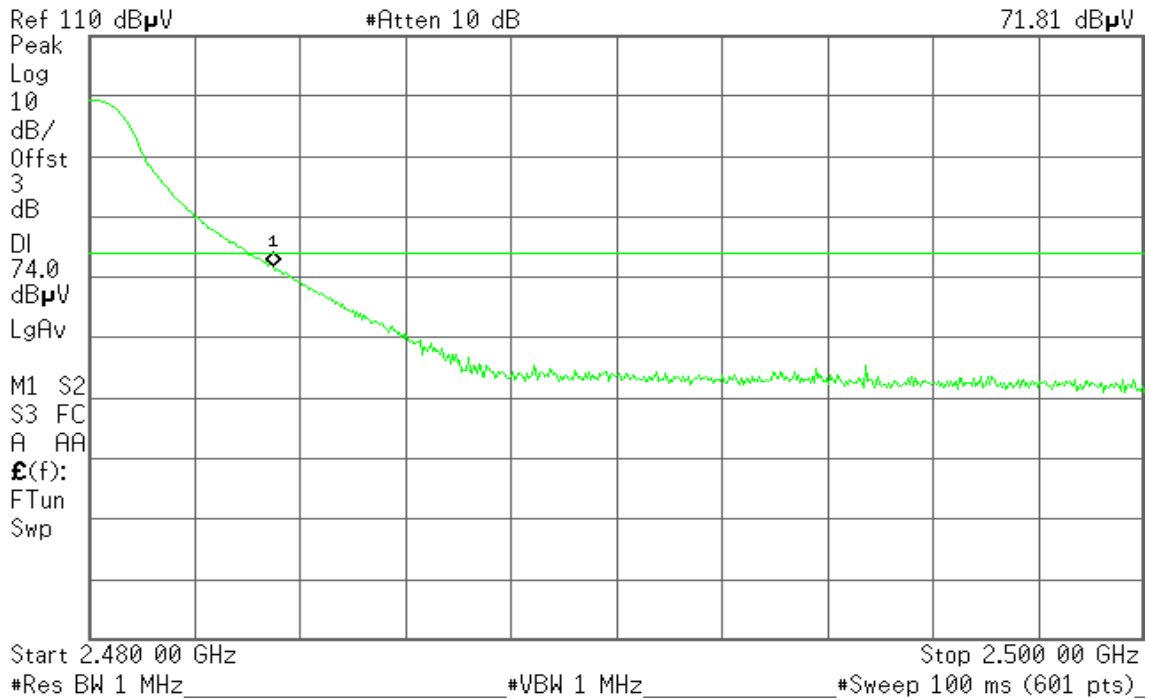

Detector mode: Average

Polarity: Vertical

Agilent

R T

Mkr1 2.483 50 GHz
42.63 dB μ V

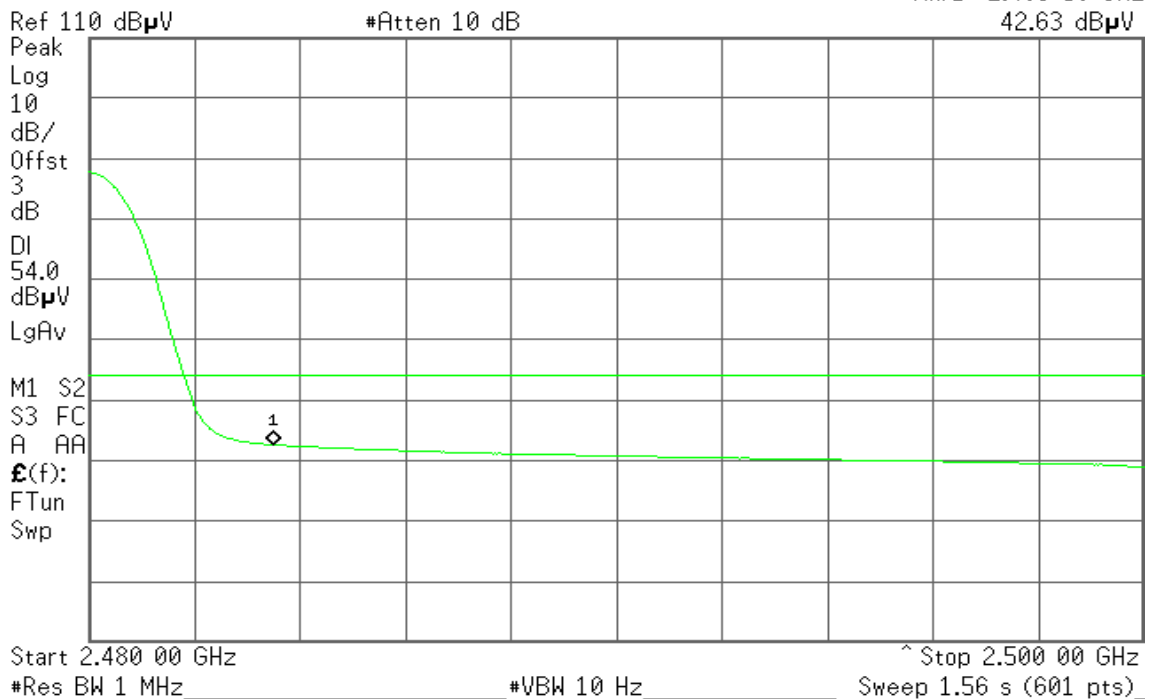



Detector mode: Peak

Polarity: Horizontal

Agilent

R T

Mkr1 2.483 50 GHz
72.21 dBµV

Ref 110 dBµV

#Atten 10 dB

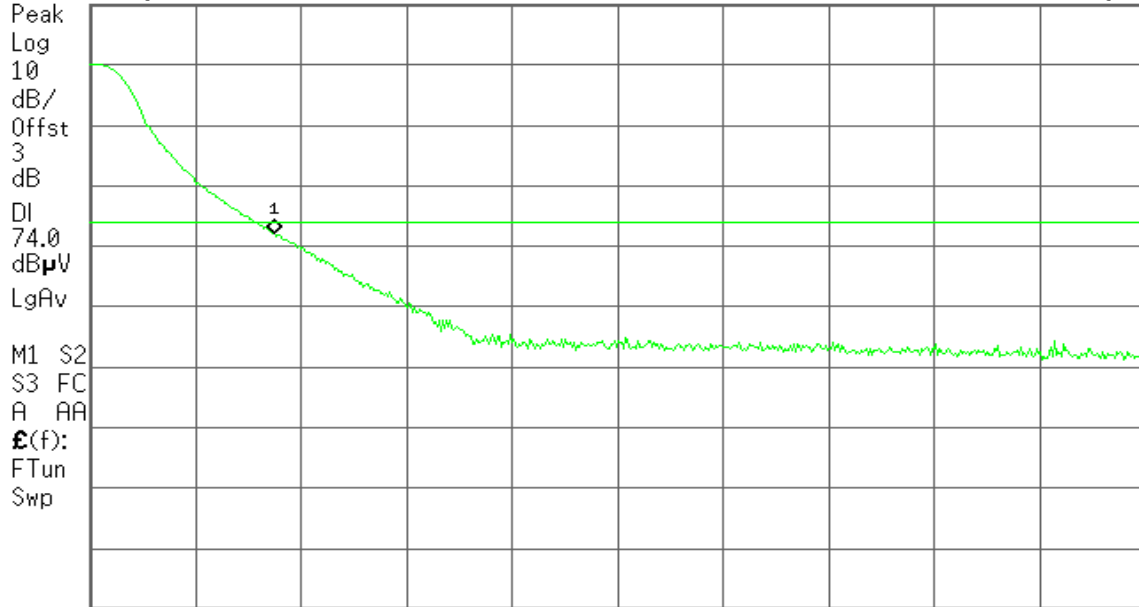

Start 2.480 00 GHz

Stop 2.500 00 GHz

#Res BW 1 MHz

#VBW 1 MHz

#Sweep 100 ms (601 pts)

Detector mode: Average

Polarity: Horizontal

Agilent

R T

Mkr1 2.483 50 GHz
42.89 dBµV

Ref 110 dBµV

#Atten 10 dB



Start 2.480 00 GHz

Stop 2.500 00 GHz

#Res BW 1 MHz

#VBW 10 Hz

Sweep 1.56 s (601 pts)



For 8DPSK / DH5

Band Edges (CH Low)

Detector mode: Peak

Polarity: Vertical

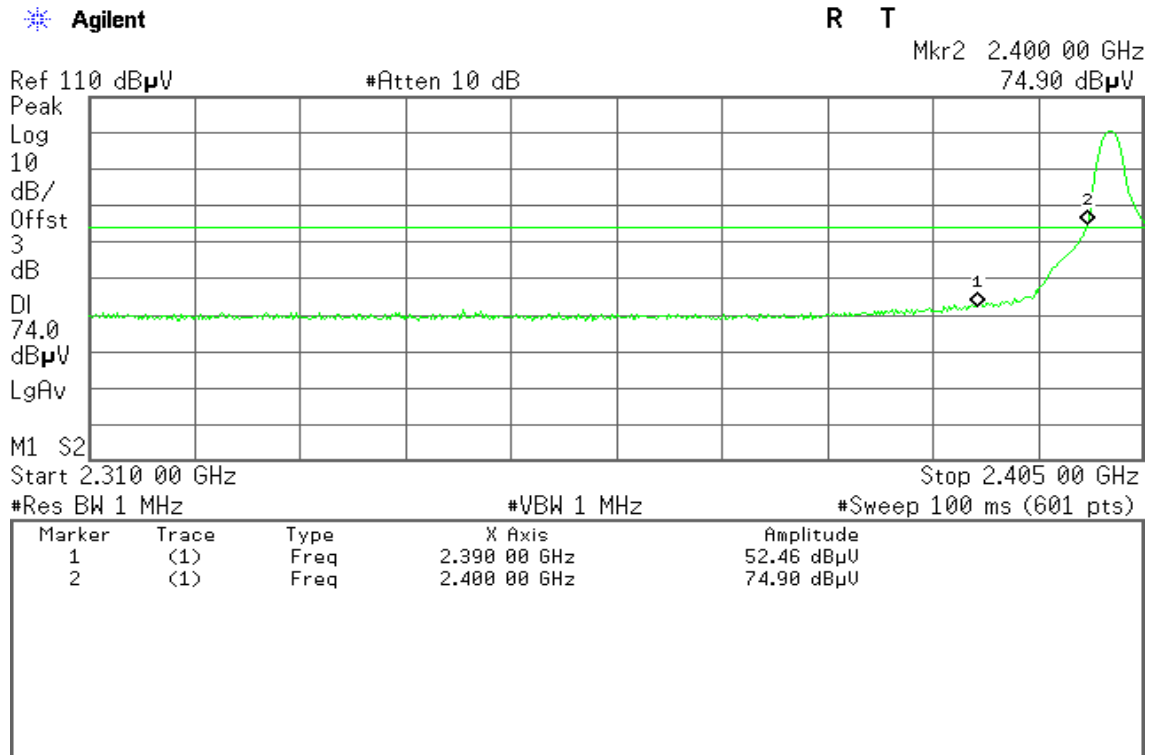

Detector mode: Average

Polarity: Vertical

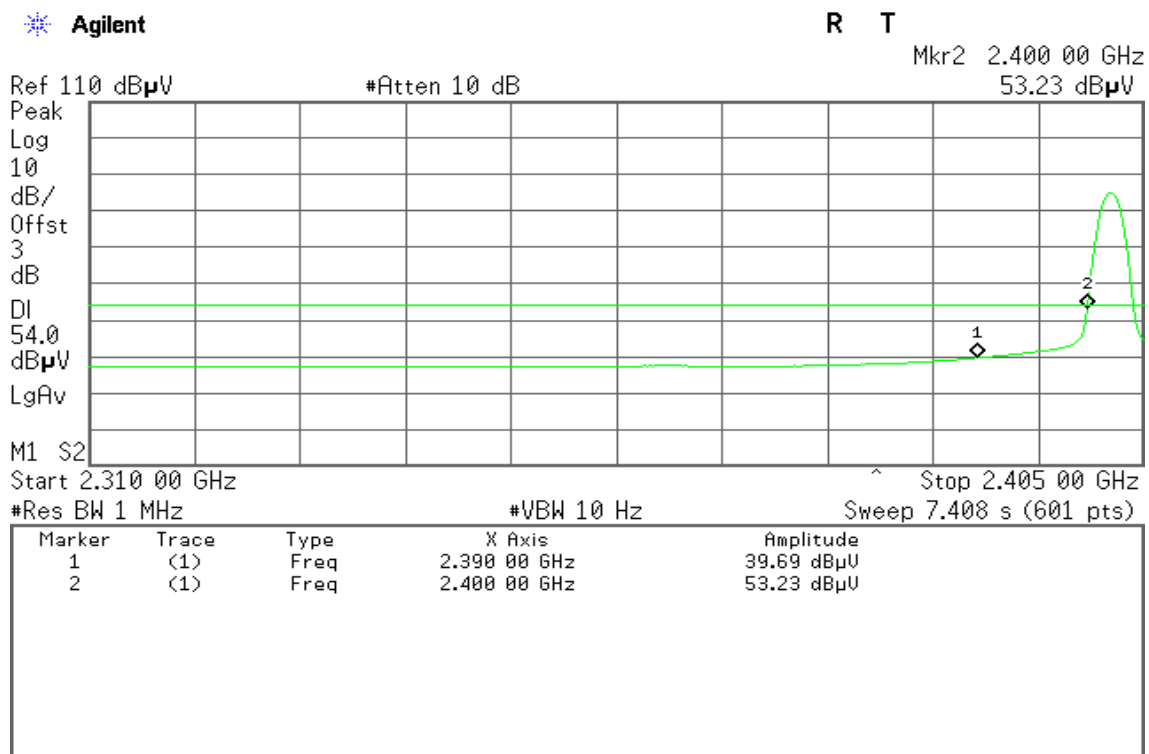



Detector mode: Peak

Polarity: Horizontal

Agilent

T

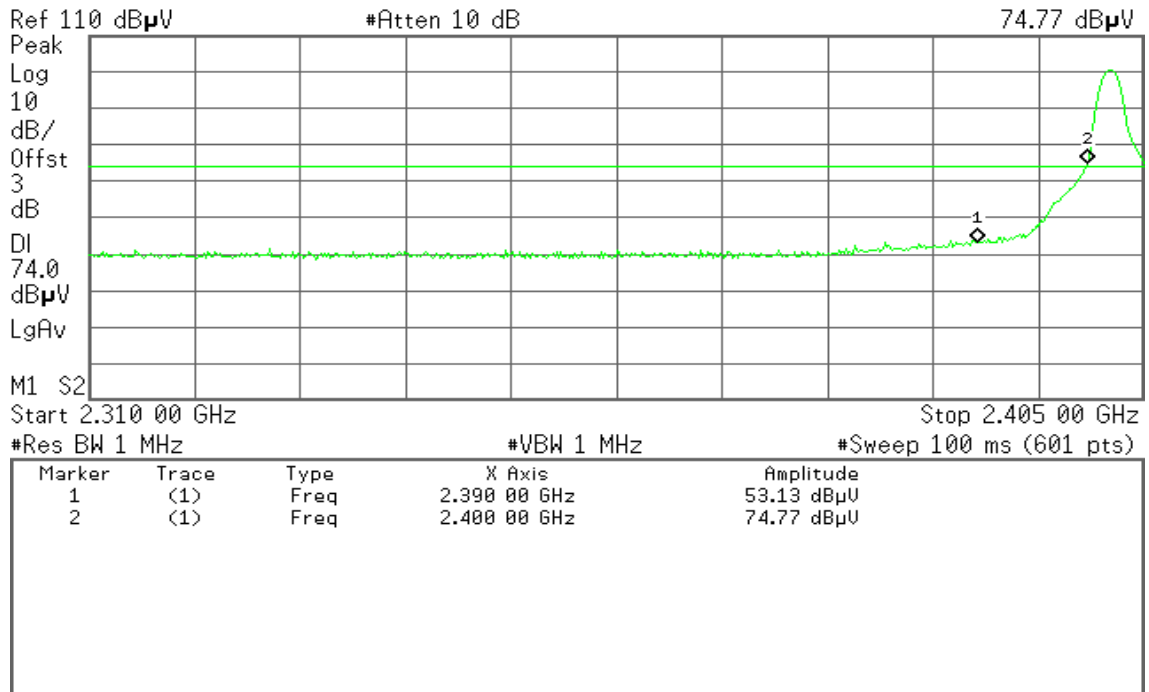

Detector mode: Average

Polarity: Horizontal

Agilent

T

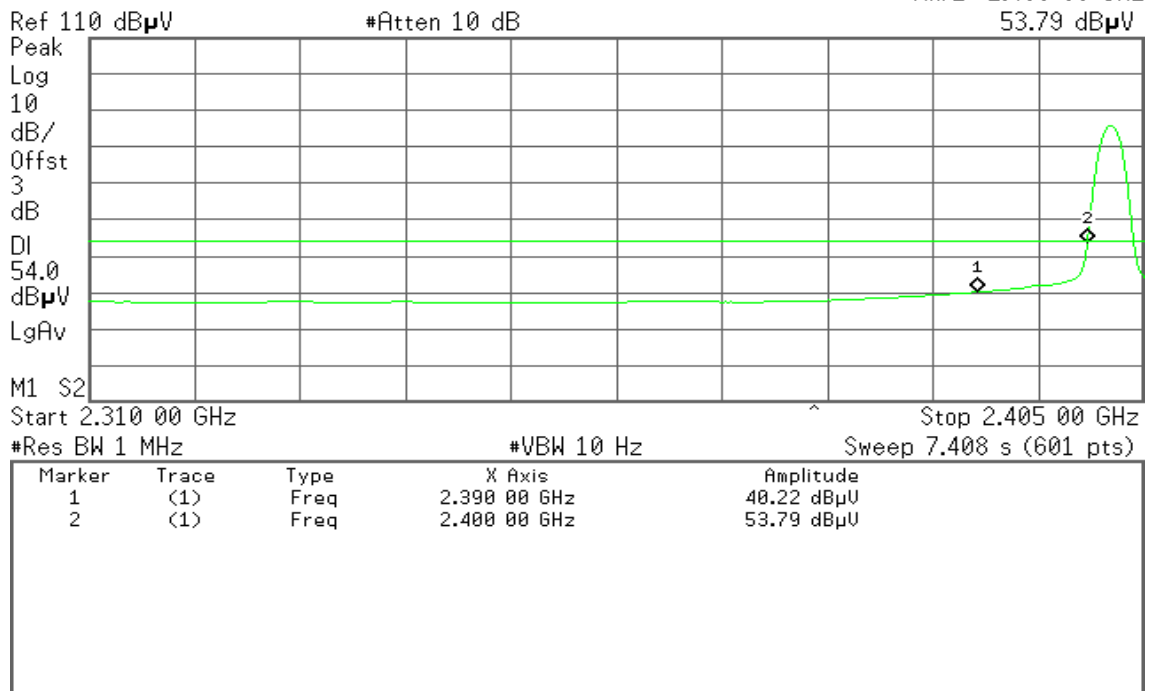



Band Edges (CH High)

Detector mode: Peak

Polarity: Vertical

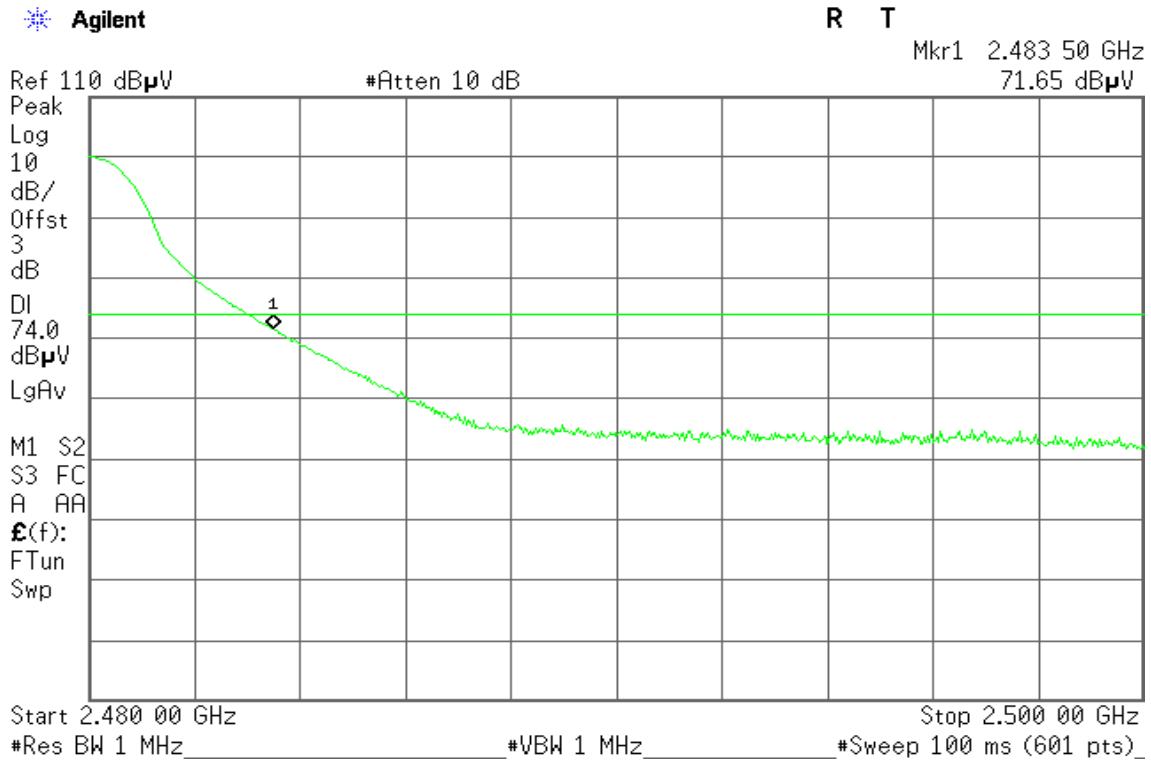

Detector mode: Average

Polarity: Vertical

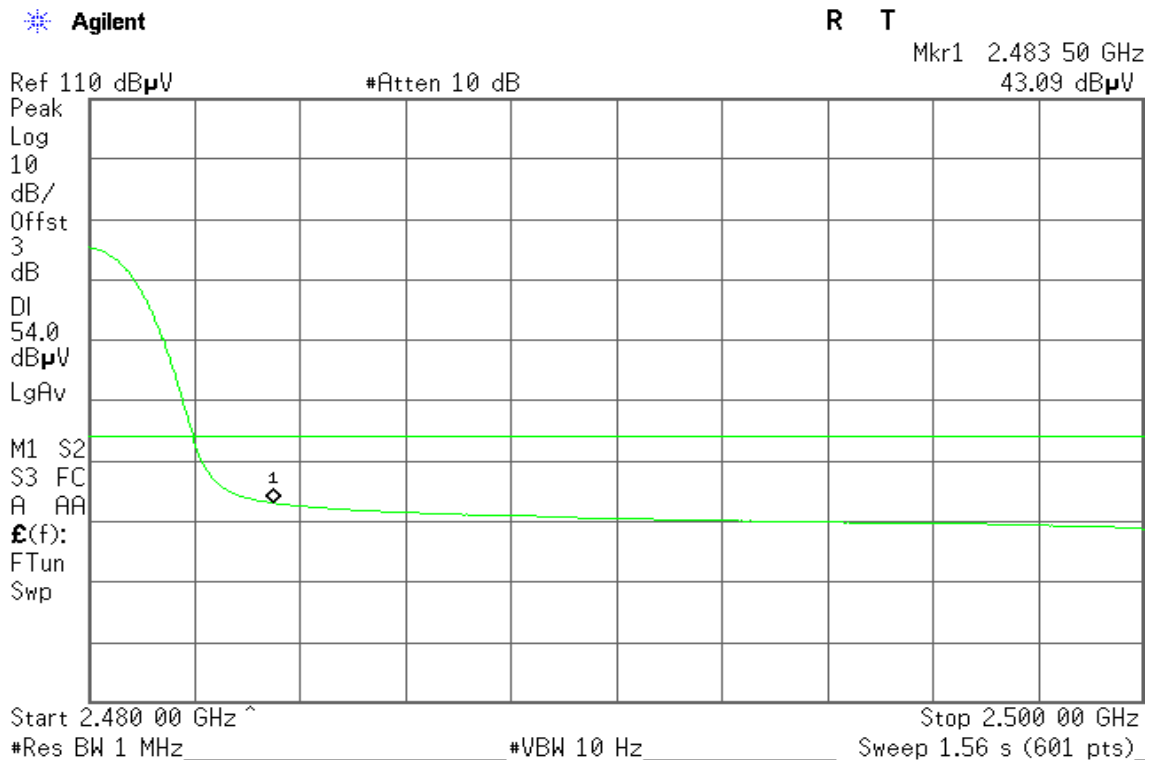



Detector mode: Peak

Polarity: Horizontal

Agilent

T

Mkr1 2.483 50 GHz
71.99 dB μ V

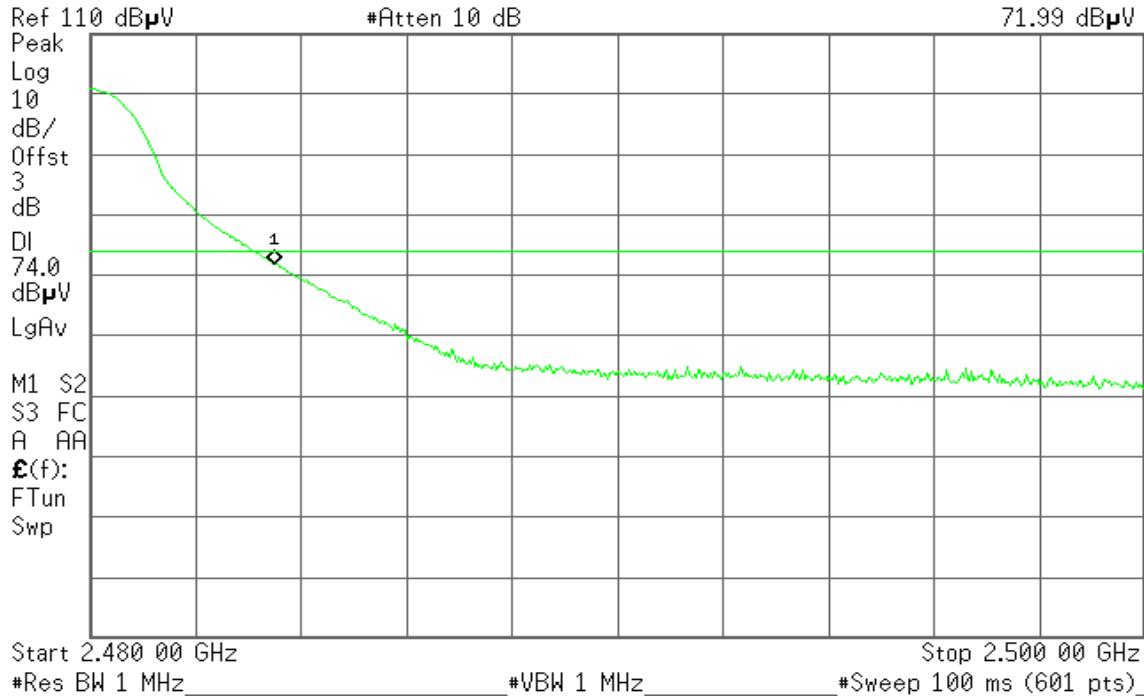

Detector mode: Average

Polarity: Horizontal

Agilent

T

Mkr1 2.483 50 GHz
43.45 dB μ V

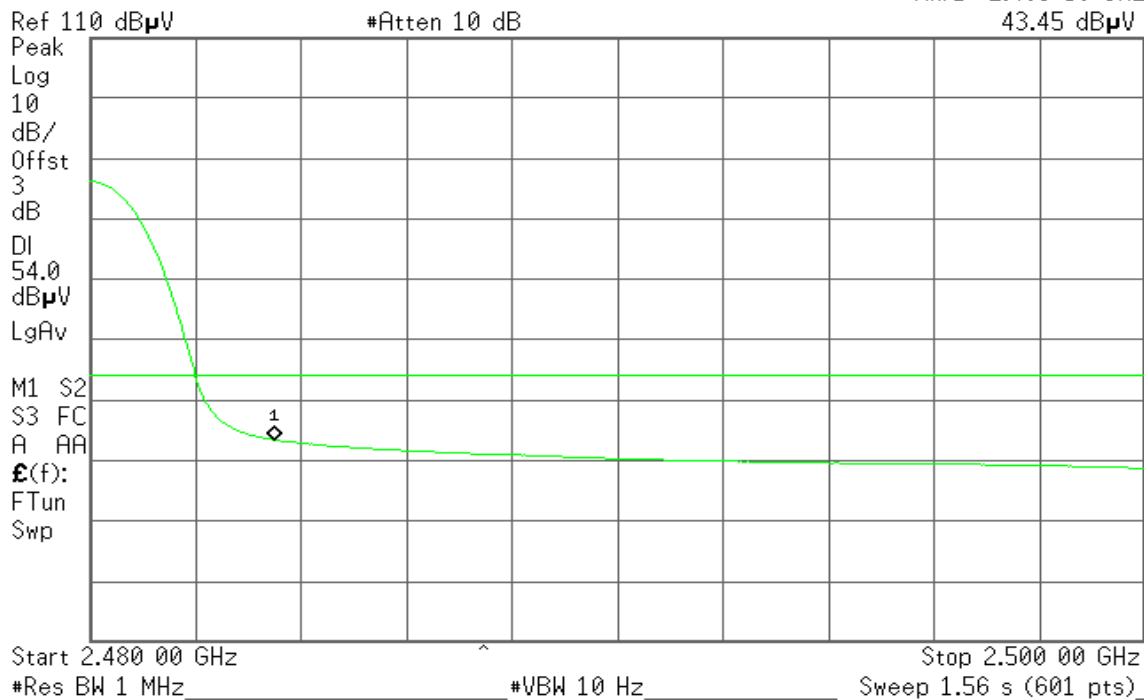



7.5 FREQUENCY SEPARATION

LIMIT

According to §15.247(a)(1), Frequency hopping systems shall have hopping channel carrier frequencies separated by a minimum of 25 kHz or the 20 dB bandwidth of the hopping channel, whichever is greater. Alternatively, frequency hopping systems operating in the 2400-2483.5 MHz band may have hopping channel carrier frequencies that are separated by 25 kHz or two-thirds of the 20 dB bandwidth of the hopping channel, whichever is greater, provided the systems operate with an output power no greater than 125 mW.

Test Configuration

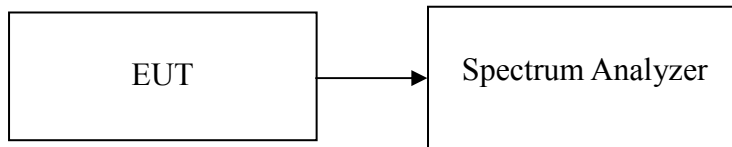

TEST PROCEDURE

1. Place the EUT on the table and set it in transmitting mode.
2. Remove the antenna from the EUT and then connect a low loss RF cable from the antenna port to the spectrum analyzer.
3. Set center frequency of spectrum analyzer = middle of hopping channel.
4. Set the spectrum analyzer as RBW = 30kHz, VBW = 100kHz, Span = 3MHz, Sweep = auto.
5. Max hold, mark 3 peaks of hopping channel and record the 3 peaks frequency.

TEST RESULTS

No non-compliance noted

Test Data

For GFSK / DH5

Channel Separation (MHz)	two-thirds of the 20 dB bandwidth (kHz)	Channel Separation Limit	Result
1.00	624.6	> two-thirds of the 20 dB bandwidth	Pass

For 8DPSK / DH5

Channel Separation (MHz)	two-thirds of the 20 dB bandwidth (kHz)	Channel Separation Limit	Result
1.00	866.6	> two-thirds of the 20 dB bandwidth	Pass



Test Plot

For GFSK / DH5

Measurement of Channel Separation

Agilent 13:43:49 Sep 24, 2010

R T

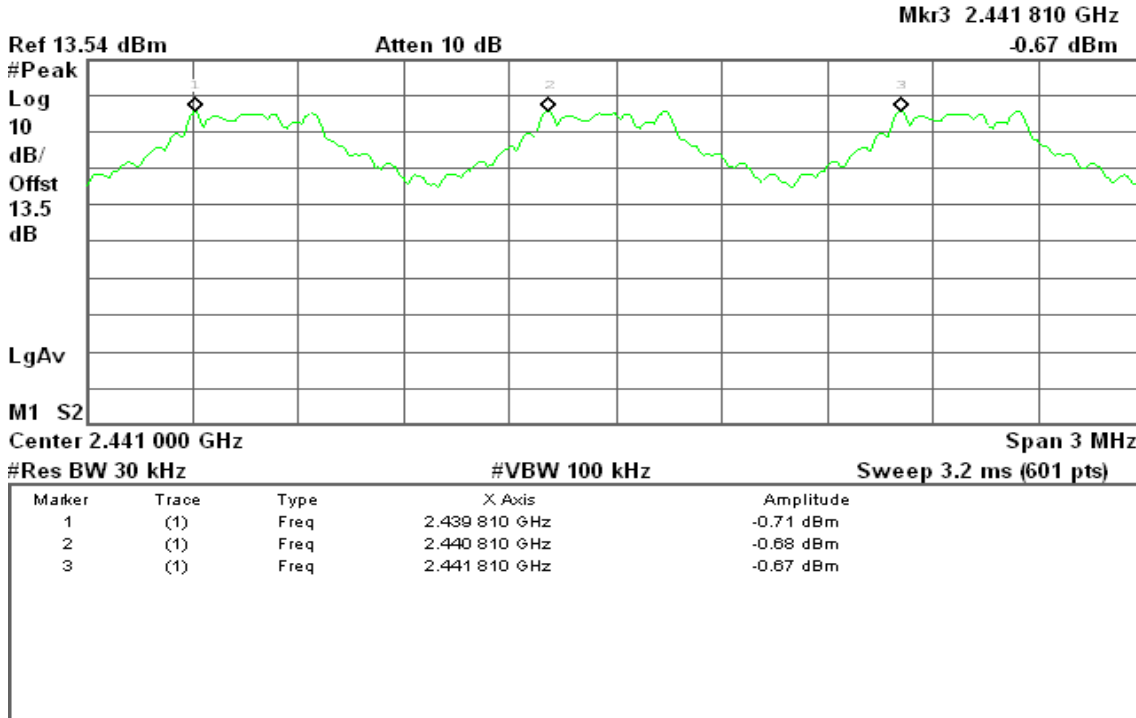

Measurement of 20dB Bandwidth

Agilent 11:27:47 Sep 24, 2010

R T

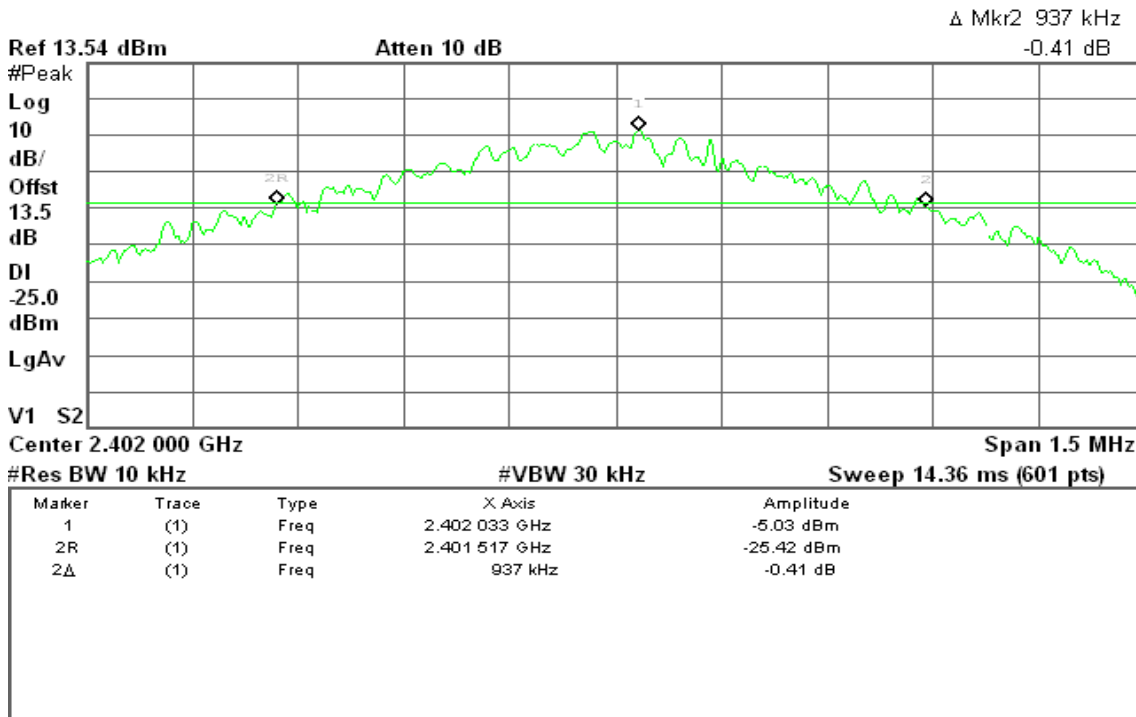



For 8DPSK / DH5

Measurement of Channel Separation

Agilent 15:01:47 Sep 24, 2010

R T

Mkr1 2.440 145 GHz

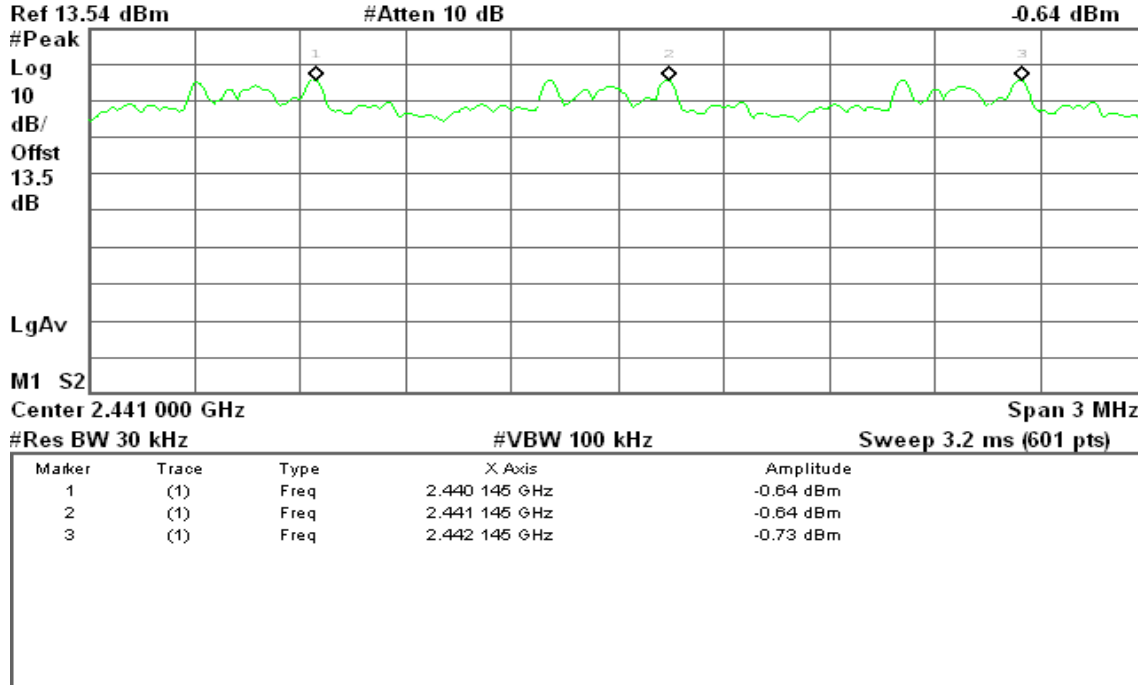

Measurement of 20dB Bandwidth

Agilent 14:38:25 Sep 24, 2010

R T

Δ Mkr2 1.300 MHz

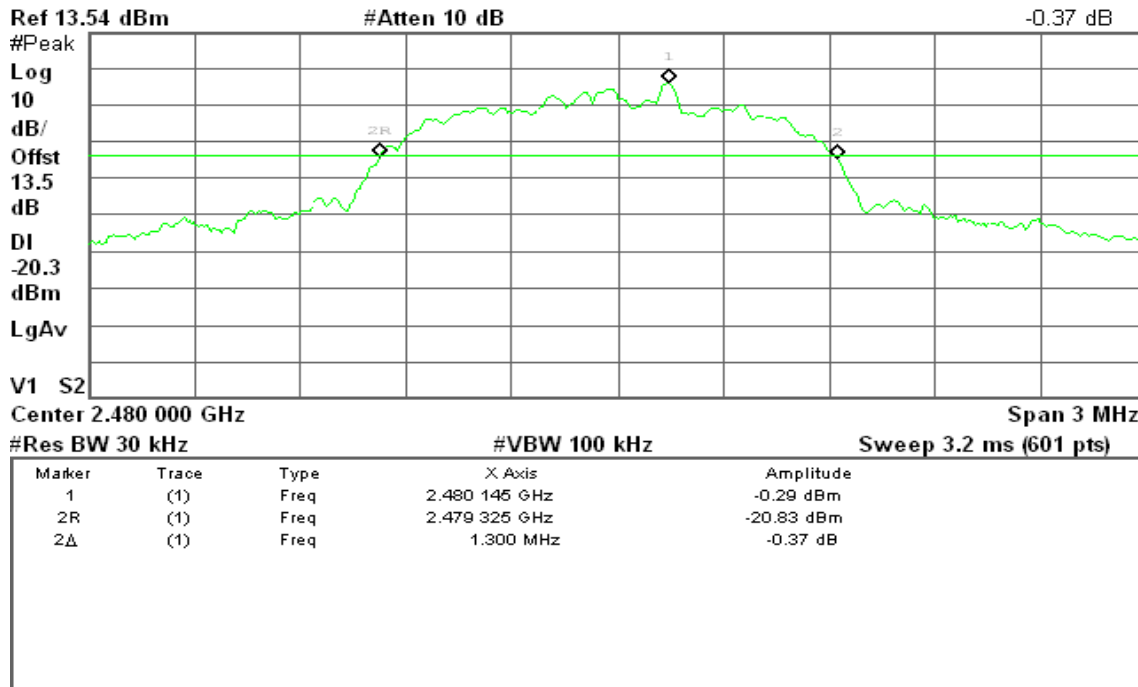



7.6 NUMBER OF HOPPING FREQUENCY

LIMIT

According to §15.247(a)(1)(iii), Frequency hopping systems operating in the 2400MHz-2483.5 MHz bands shall use at least 15 hopping frequencies.

Test Configuration

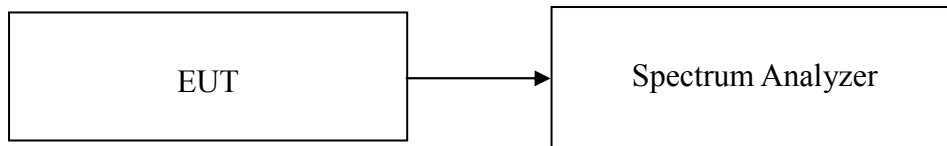

TEST PROCEDURE

1. Place the EUT on the table and set it in transmitting mode.
2. Remove the antenna from the EUT and then connect a low loss RF cable from the antenna port to the spectrum analyzer.
3. Set spectrum analyzer Start=2400MHz, Stop = 2441.5MHz, Sweep = auto and Start=2441.5MHz, Stop = 2483.5MHz, Sweep = auto.
4. Set the spectrum analyzer as RBW, VBW=510kHz.
5. Max hold, view and count how many channel in the band.

TEST RESULTS

No non-compliance noted

Test Data

For GFSK / 8DPSK

Result (No. of CH)	Limit (No. of CH)	Result
79	>15	PASS



Test Plot

For GFSK

Channel Number

2.4 GHz – 2.4415 GHz

Agilent 11:56:04 Sep 24, 2010

R T

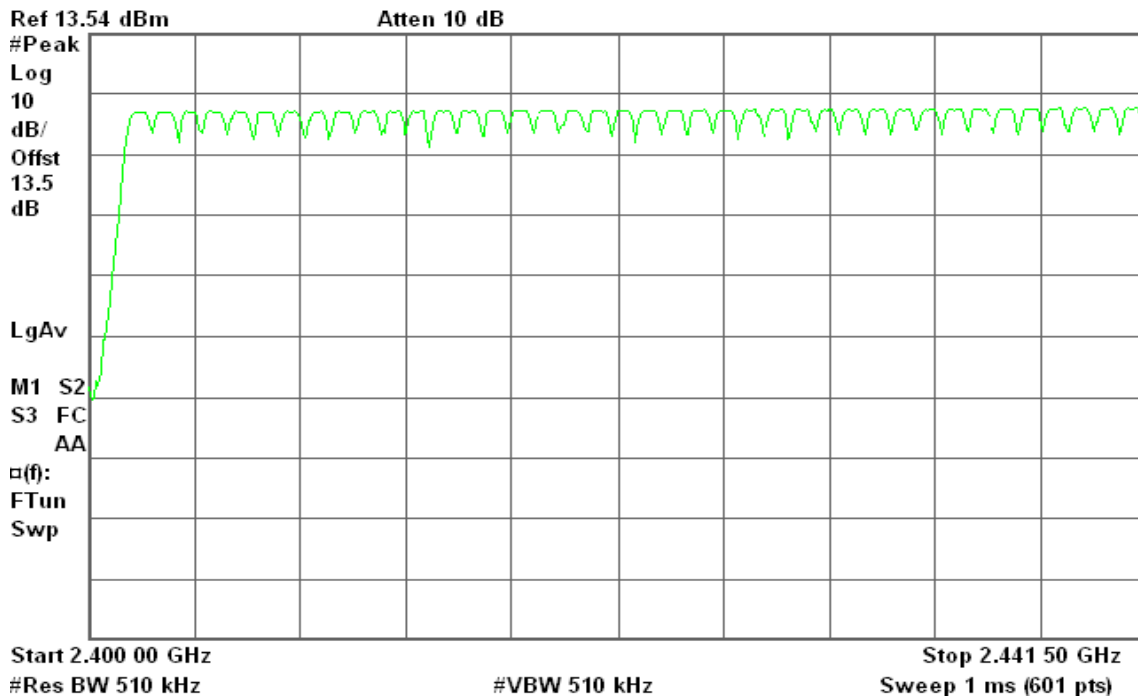

2.4415 GHz – 2.4835 GHz

Agilent 11:56:22 Sep 24, 2010

R T

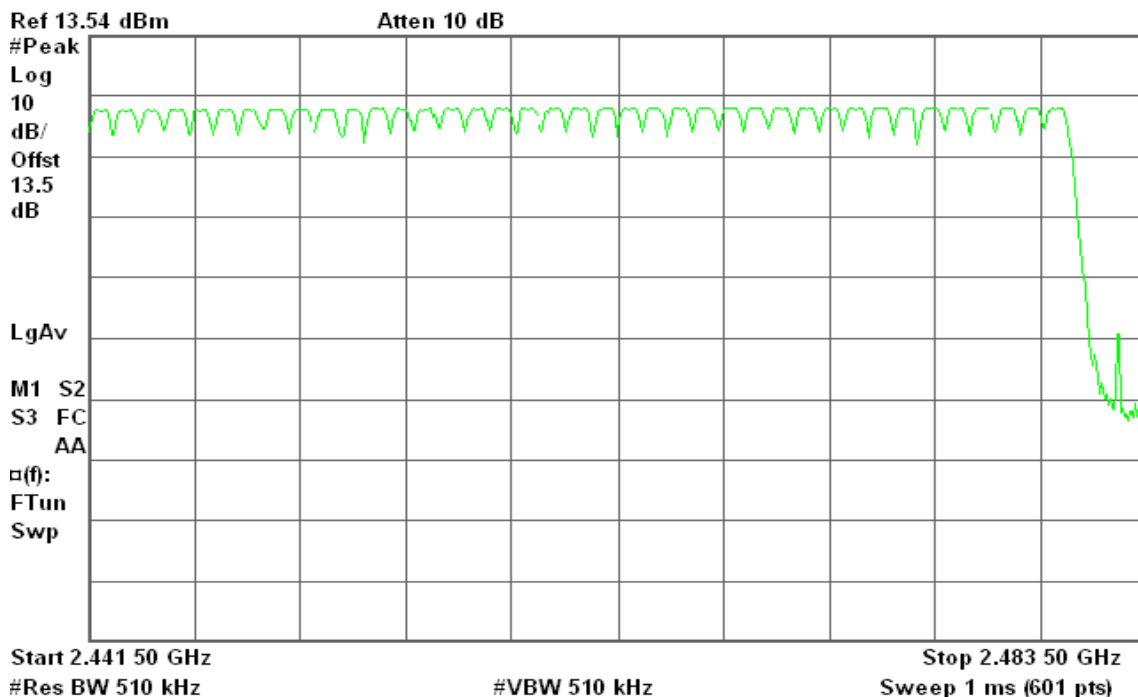



For 8DPSK

Channel Number

2.4 GHz – 2.4415 GHz

Agilent 15:19:35 Sep 24, 2010

R T

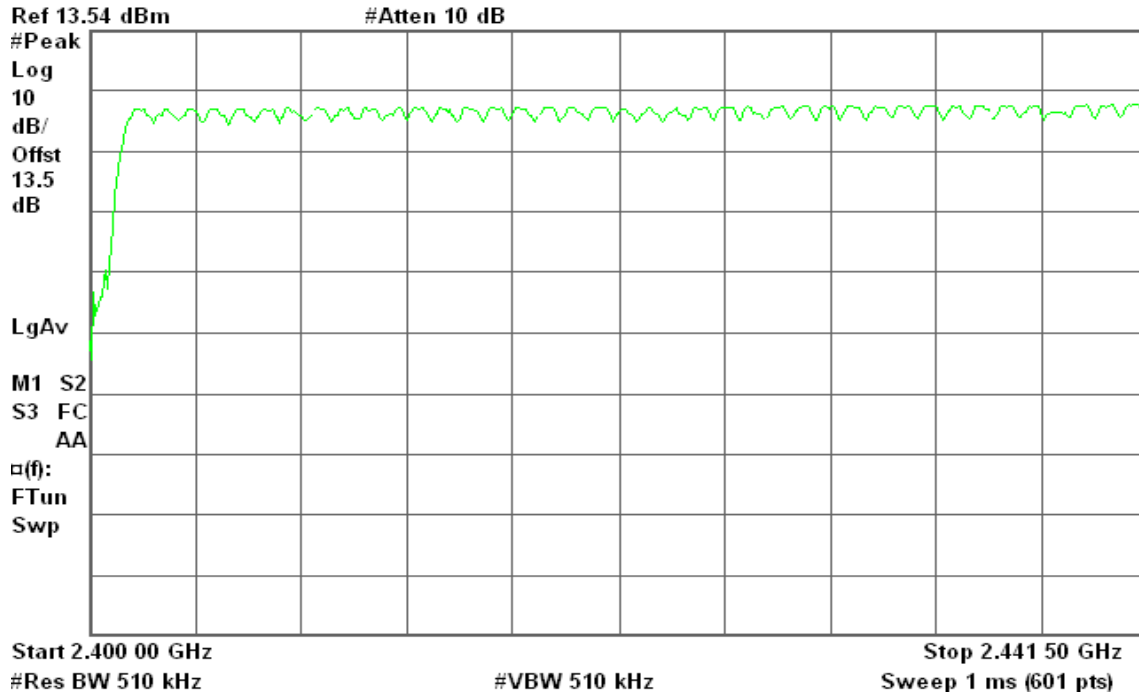

2.4415 GHz – 2.4835 GHz

Agilent 15:22:46 Sep 24, 2010

R T

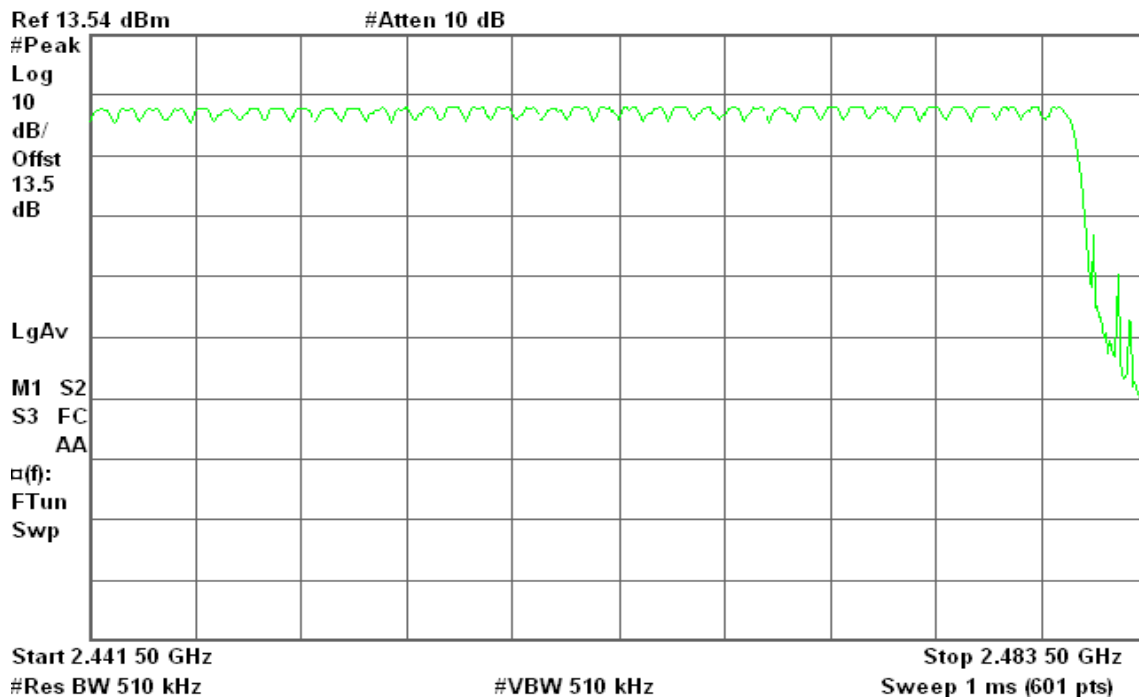



7.7 TIME OF OCCUPANCY (DWELL TIME)

LIMIT

According to §15.247(a)(1)(iii), Frequency hopping systems operating in the 2400MHz-2483.5 MHz bands. The average time of occupancy on any channels shall not greater than 0.4 s within a period 0.4 s multiplied by the number of hopping channels employed.

Test Configuration

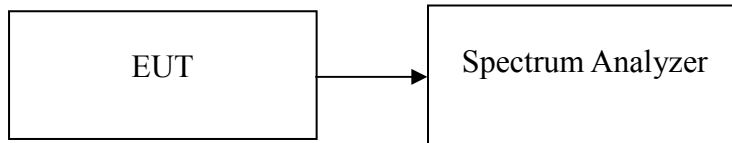

TEST PROCEDURE

1. Place the EUT on the table and set it in transmitting mode.
2. Remove the antenna from the EUT and then connect a low loss RF cable from the antenna port to the spectrum analyzer.
3. Set center frequency of spectrum analyzer = operating frequency.
4. Set the spectrum analyzer as RBW=1MHz, VBW=1MHz, Span = 0Hz, Sweep = auto.
5. Repeat above procedures until all frequency measured were complete.

TEST RESULTS

No non-compliance noted



Test Data

For GFSK

DH 1

CH Low: $0.3833 * (1600/2)/79 * 31.6 = 122.7$ (ms)

CH Mid: $0.3833 * (1600/2)/79 * 31.6 = 122.7$ (ms)

CH High: $0.3667 * (1600/2)/79 * 31.6 = 117.3$ (ms)

CH	Pulse Time (ms)	Total of Dwell (ms)	Period Time (s)	Limit (ms)	Result
Low	0.3833	122.7	31.60	400.00	PASS
Mid	0.3833	122.7	31.60		PASS
High	0.3667	117.3	31.60		PASS

DH 3

CH Low: $1.617 * (1600/4)/79 * 31.6 = 258.7$ (ms)

CH Mid: $1.617 * (1600/4)/79 * 31.6 = 258.7$ (ms)

CH High: $1.633 * (1600/4)/79 * 31.6 = 261.3$ (ms)

CH	Pulse Time (ms)	Total of Dwell (ms)	Period Time (s)	Limit (ms)	Result
Low	1.617	258.7	31.60	400.00	PASS
Mid	1.617	258.7	31.60		PASS
High	1.633	261.3	31.60		PASS

DH 5

CH Low: $2.883 * (1600/6)/79 * 31.6 = 307.5$ (ms)

CH Mid: $2.883 * (1600/6)/79 * 31.6 = 307.5$ (ms)

CH High: $2.883 * (1600/6)/79 * 31.6 = 307.5$ (ms)

CH	Pulse Time (ms)	Total of Dwell (ms)	Period Time (s)	Limit (ms)	Result
Low	2.883	307.5	31.60	400.00	PASS
Mid	2.883	307.5	31.60		PASS
High	2.883	307.5	31.60		PASS



Test Plot

For GFSK

DH 1

CH Low

Agilent 11:48:31 Sep 24, 2010

R T

Δ Mkr1 383.3 μs
0.01 dB

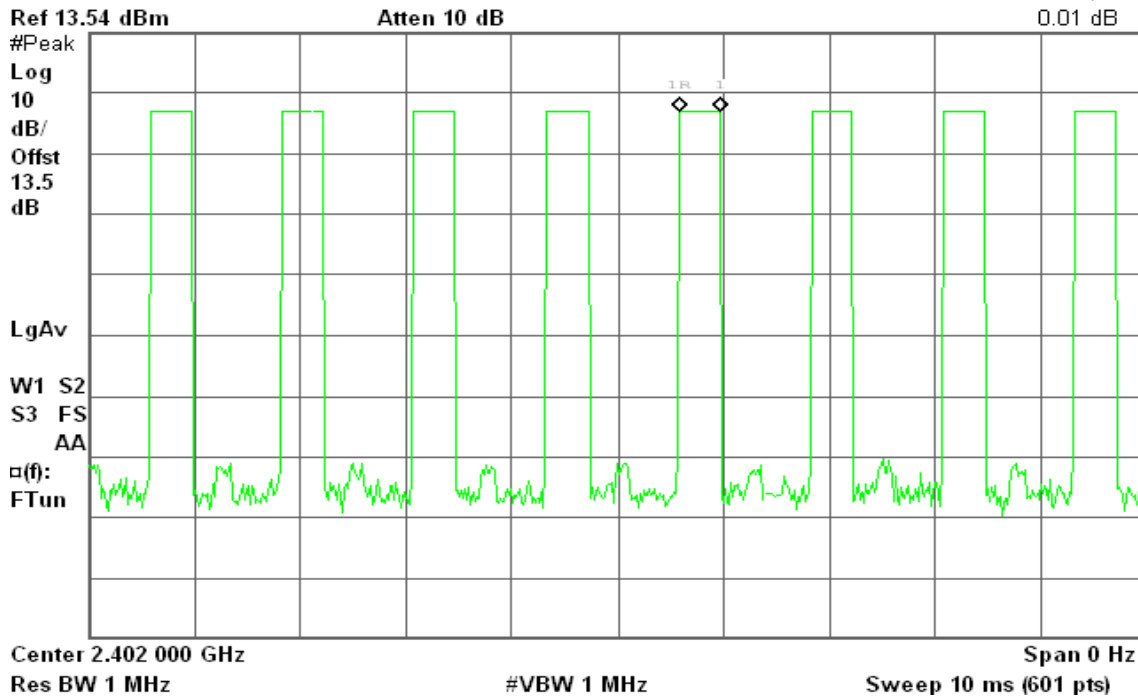

CH Mid

Agilent 11:50:43 Sep 24, 2010

R T

Δ Mkr1 383.3 μs
-2.58 dB

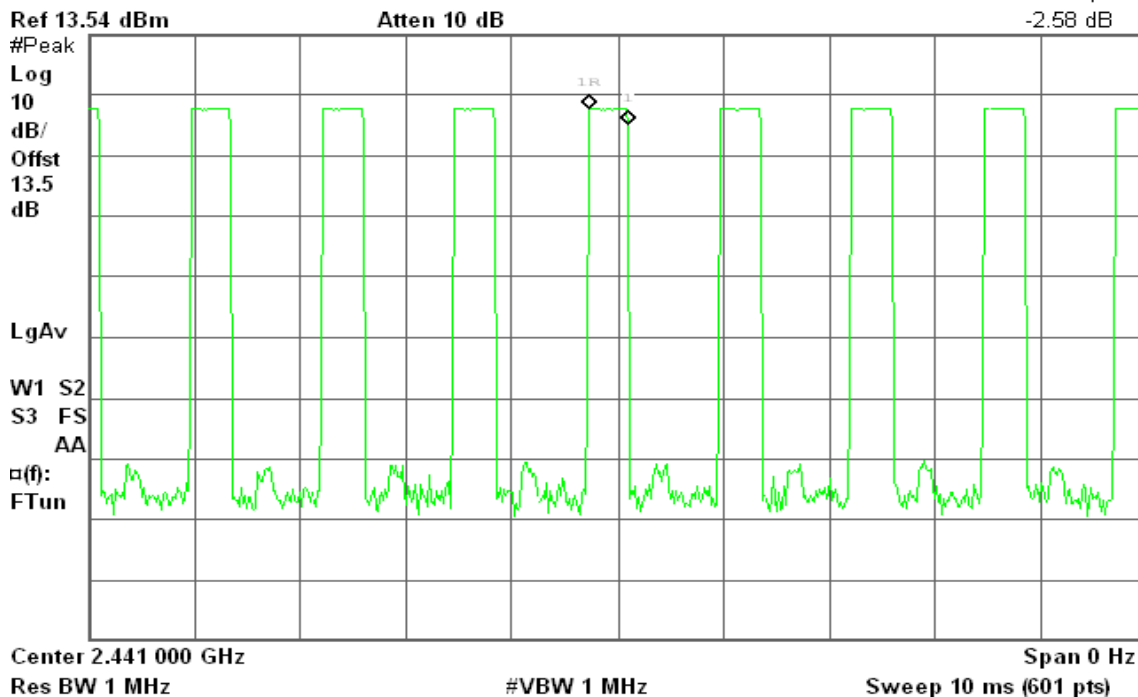



CH High

Agilent 11:53:28 Sep 24, 2010

R T

Δ Mkr1 366.7 μs
0.00 dB

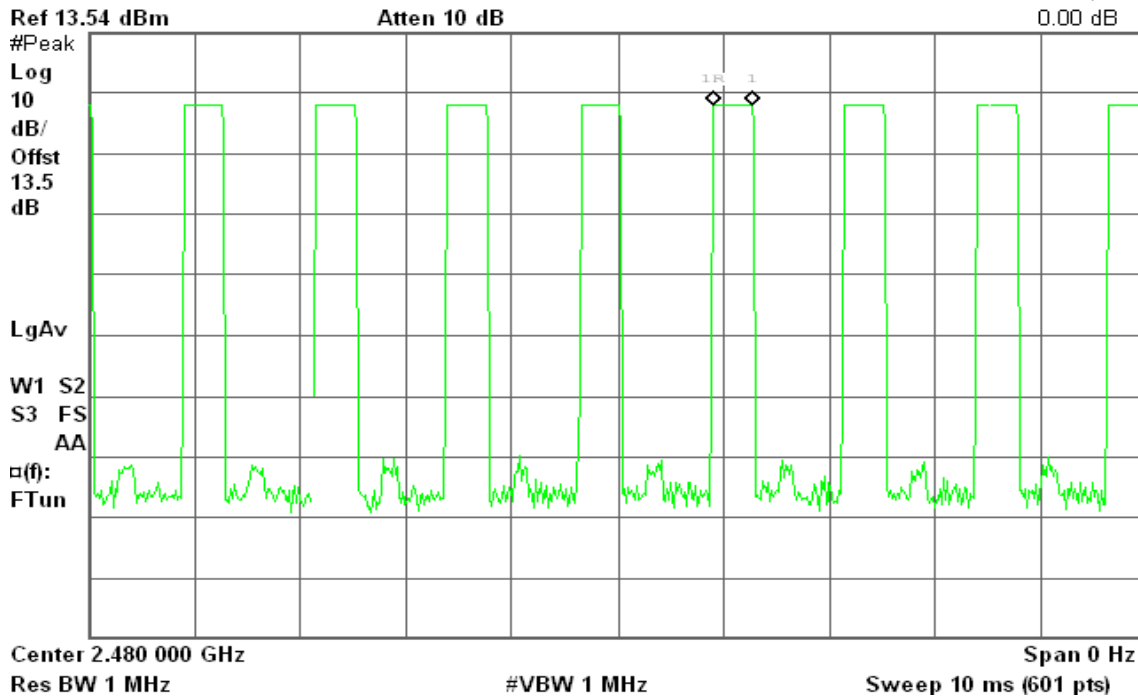

DH 3

CH Low

Agilent 11:49:42 Sep 24, 2010

R T

Δ Mkr1 1.617 ms
-0.02 dB

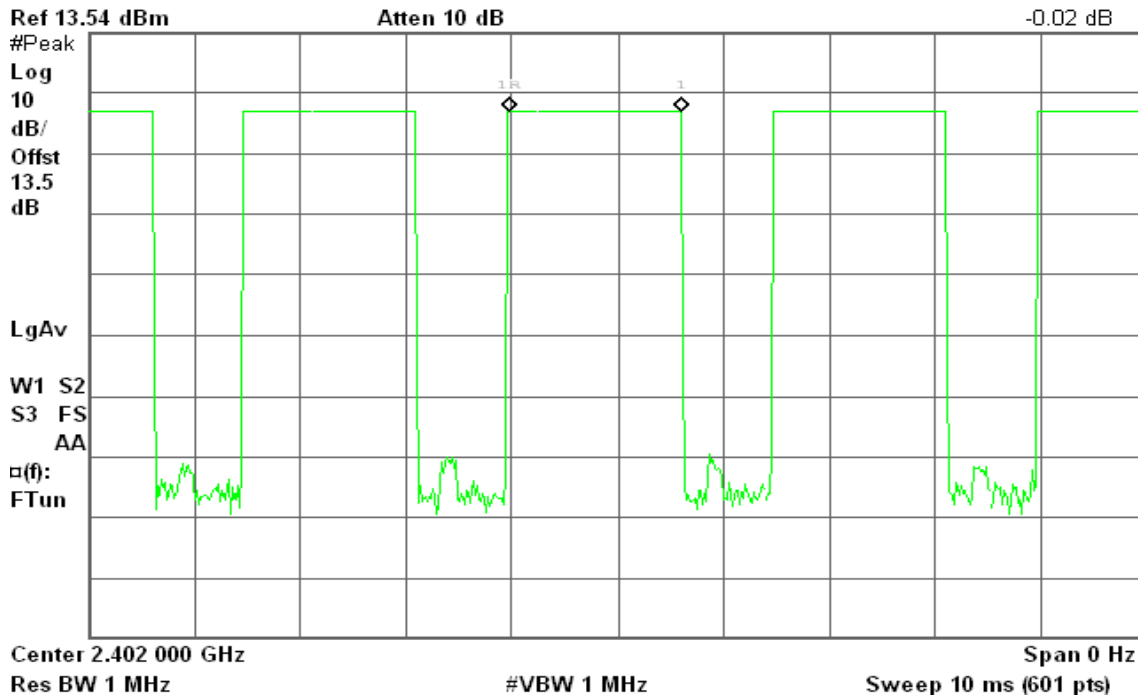



CH Mid

Agilent 11:51:37 Sep 24, 2010

R T

Δ Mkr1 1.617 ms
-0.01 dB

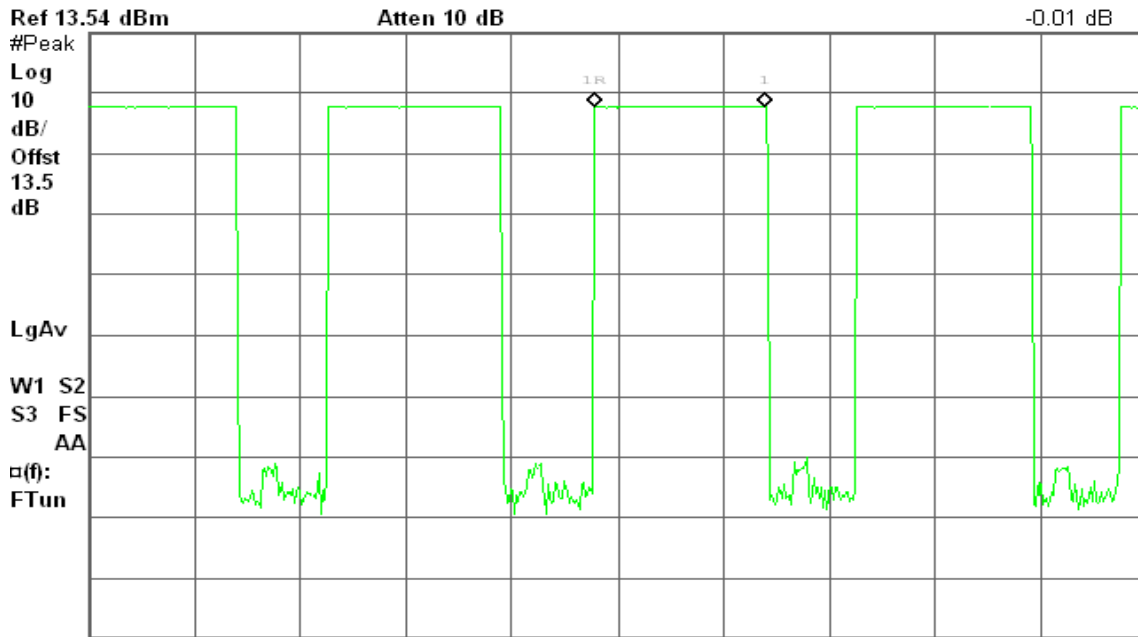

Center 2.441 000 GHz Span 0 Hz
Res BW 1 MHz #VBW 1 MHz Sweep 10 ms (601 pts)

CH High

Agilent 11:54:13 Sep 24, 2010

R T

Δ Mkr1 1.633 ms
-0.02 dB

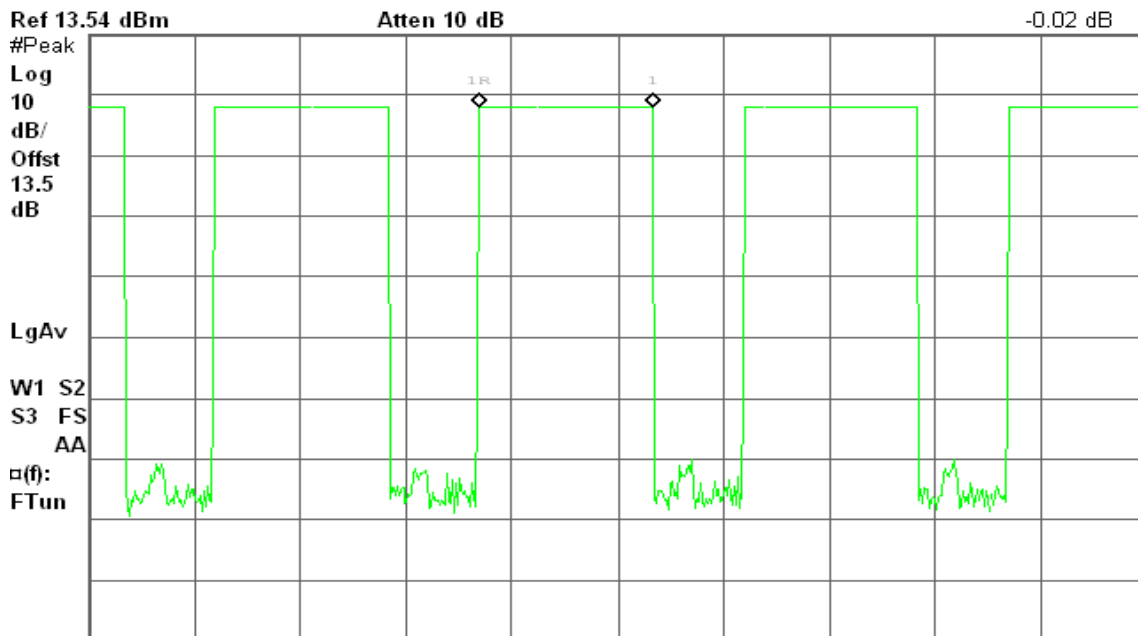

Center 2.480 000 GHz Span 0 Hz
Res BW 1 MHz #VBW 1 MHz Sweep 10 ms (601 pts)



DH 5

CH Low

Agilent 11:47:39 Sep 24, 2010

R T

Δ Mkr1 2.883 ms
-0.01 dB

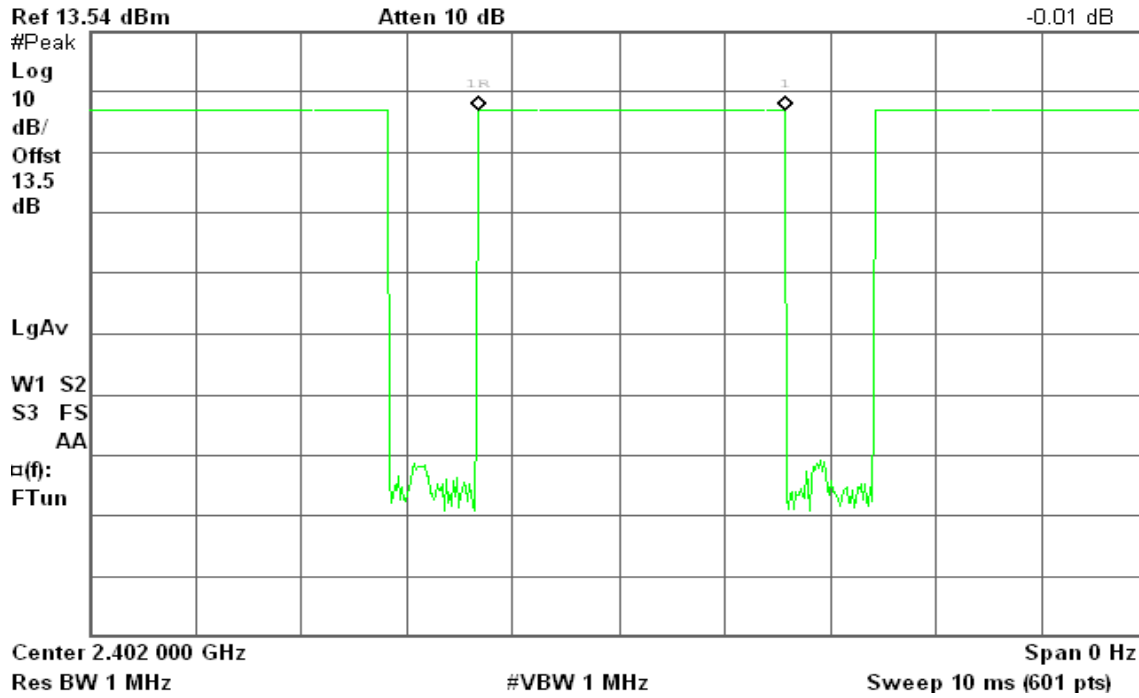

CH Mid

Agilent 11:52:27 Sep 24, 2010

R T

Δ Mkr1 2.883 ms
0.01 dB

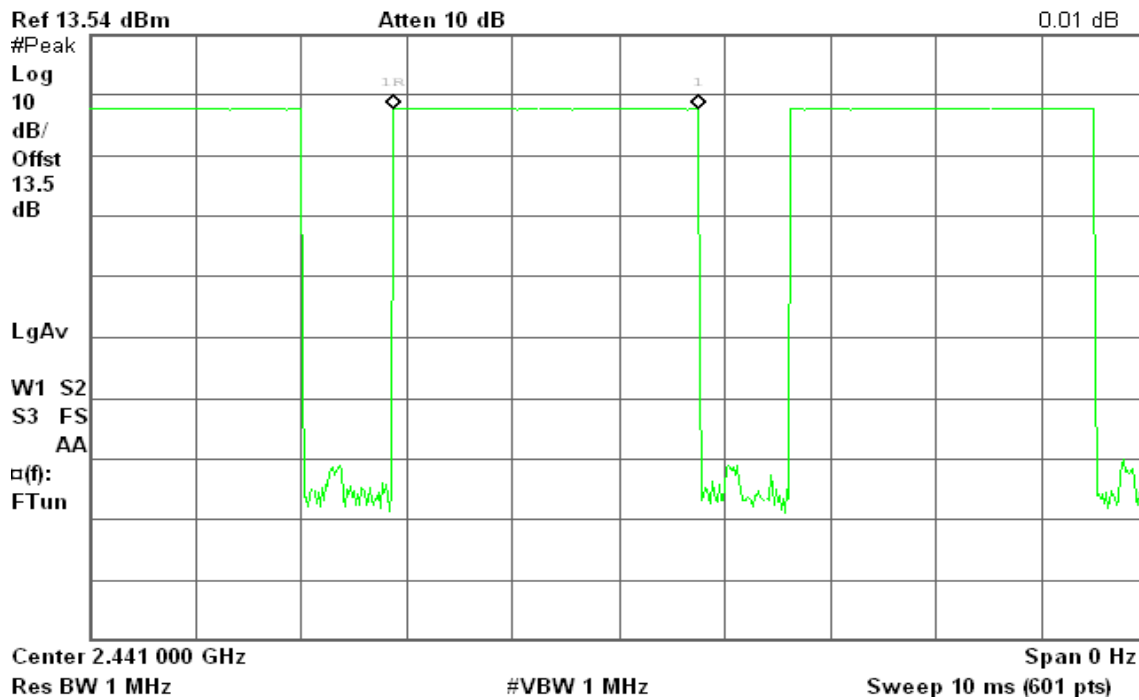



CH High

Agilent 11:54:59 Sep 24, 2010

R T

Δ Mkr1 2.883 ms
-0.01 dB

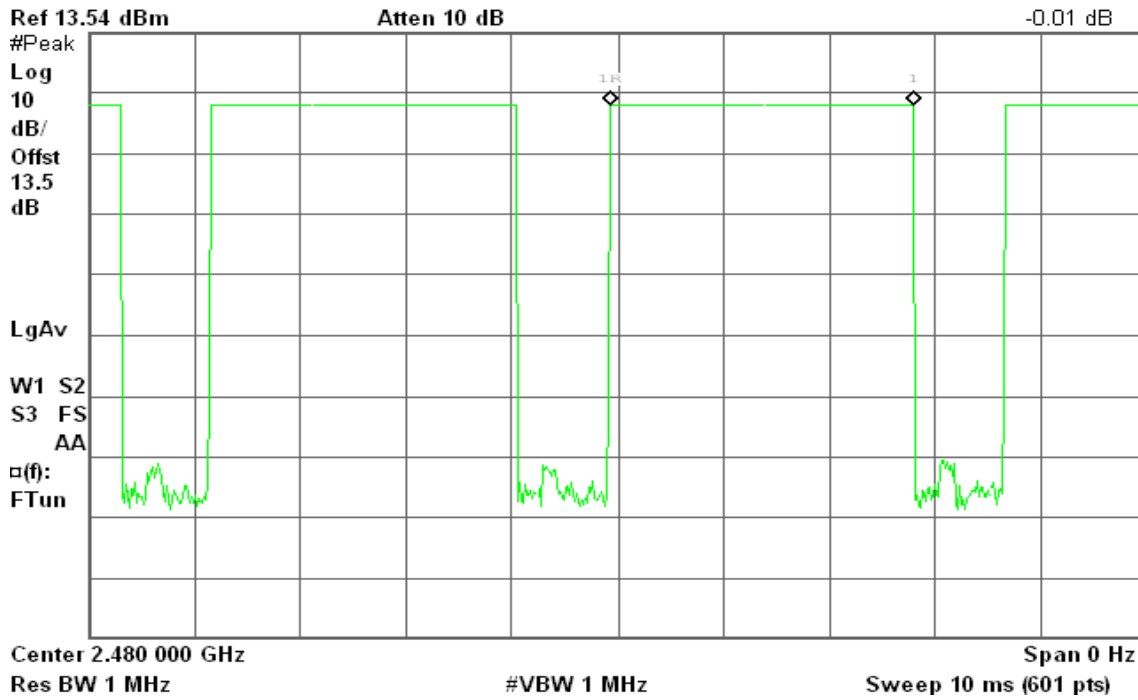



Test Data

For 8DPSK

DH 1

CH Low: $0.3833 * (1600/2)/79 * 31.6 = 122.7$ (ms)

CH Mid: $0.3833 * (1600/2)/79 * 31.6 = 122.7$ (ms)

CH High: $0.3833 * (1600/2)/79 * 31.6 = 122.7$ (ms)

CH	Pulse Time (ms)	Total of Dwell (ms)	Period Time (s)	Limit (ms)	Result
Low	0.3833	122.7	31.60	400.00	PASS
Mid	0.3833	122.7	31.60		PASS
High	0.3833	122.7	31.60		PASS

DH 3

CH Low: $1.633 * (1600/4)/79 * 31.6 = 261.3$ (ms)

CH Mid: $1.633 * (1600/4)/79 * 31.6 = 261.3$ (ms)

CH High: $1.633 * (1600/4)/79 * 31.6 = 261.3$ (ms)

CH	Pulse Time (ms)	Total of Dwell (ms)	Period Time (s)	Limit (ms)	Result
Low	1.633	261.3	31.60	400.00	PASS
Mid	1.633	261.3	31.60		PASS
High	1.633	261.3	31.60		PASS

DH 5

CH Low: $2.883 * (1600/6)/79 * 31.6 = 307.5$ (ms)

CH Mid: $2.883 * (1600/6)/79 * 31.6 = 307.5$ (ms)

CH High: $2.883 * (1600/6)/79 * 31.6 = 307.5$ (ms)

CH	Pulse Time (ms)	Total of Dwell (ms)	Period Time (s)	Limit (ms)	Result
Low	2.883	307.5	31.60	400.00	PASS
Mid	2.883	307.5	31.60		PASS
High	2.883	307.5	31.60		PASS



For 8DPSK

DH 1

CH Low

Agilent 14:26:33 Sep 24, 2010

R T

Δ Mkr1 383.3 μs
0.57 dB

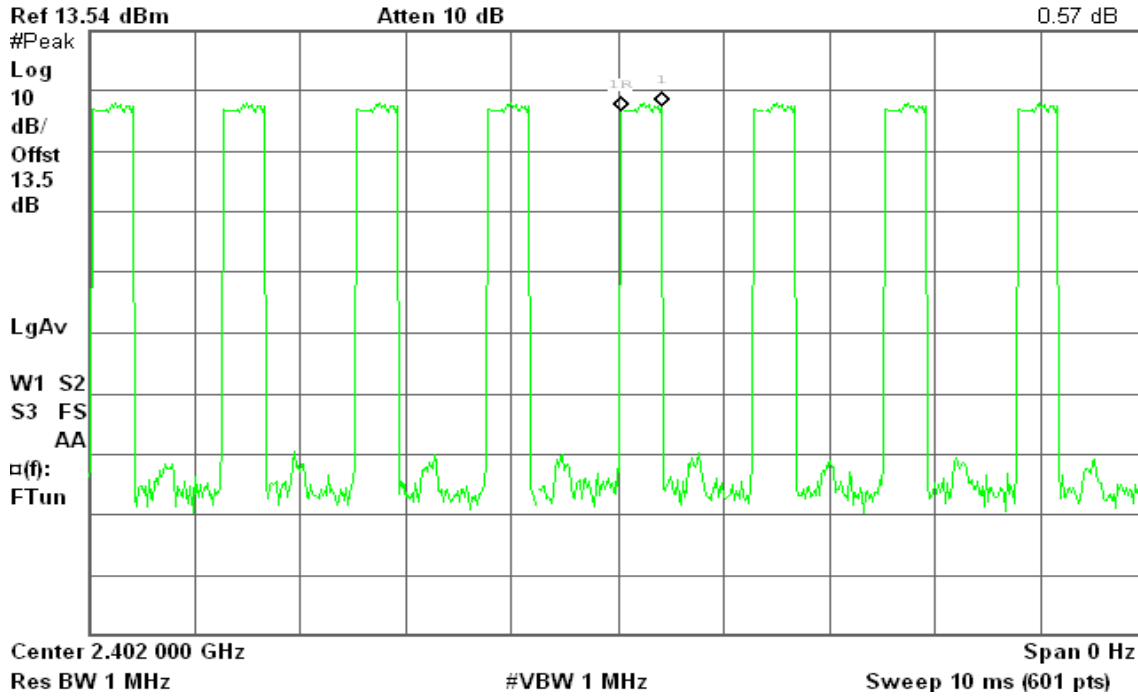

CH Mid

Agilent 14:31:01 Sep 24, 2010

R T

Δ Mkr1 383.3 μs
0.55 dB

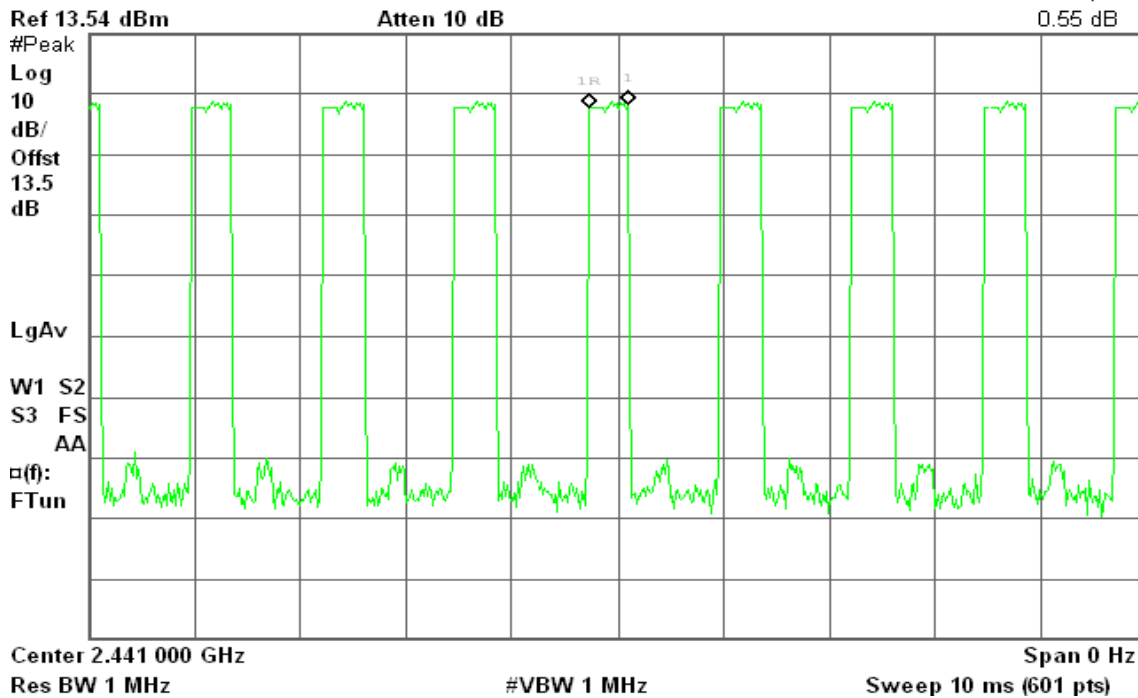



CH High

Agilent 14:34:24 Sep 24, 2010

R T

Δ Mkr1 383.3 μs
0.56 dB

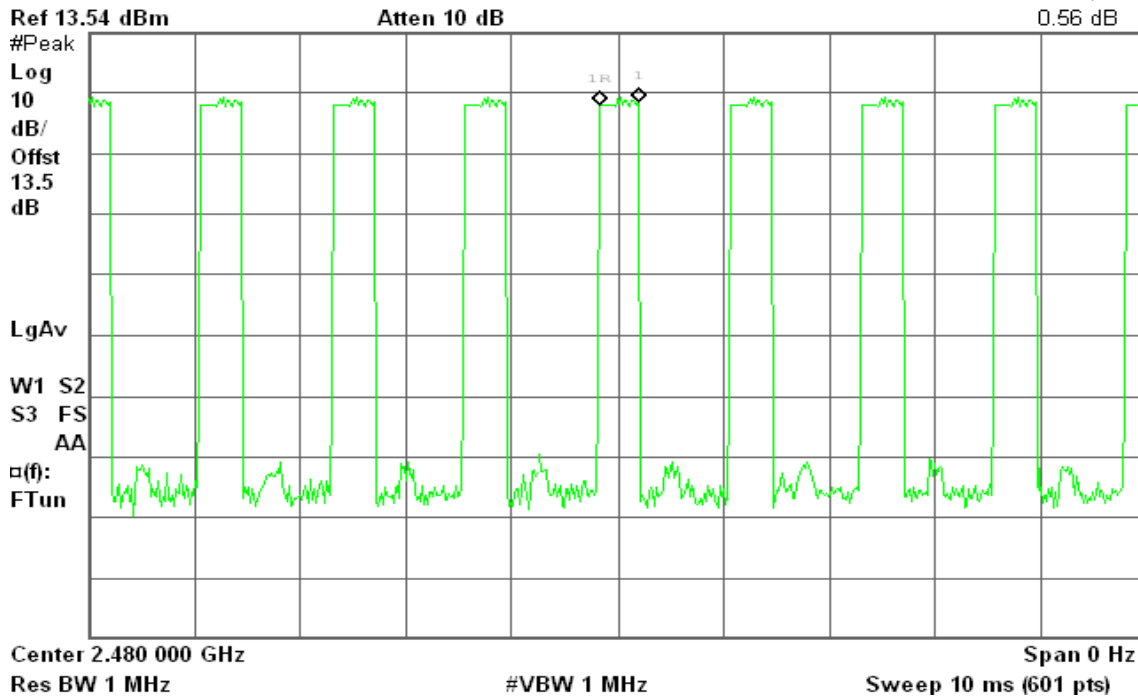

DH 3

CH Low

Agilent 14:27:37 Sep 24, 2010

R L

Δ Mkr1 1.633 ms
0.41 dB

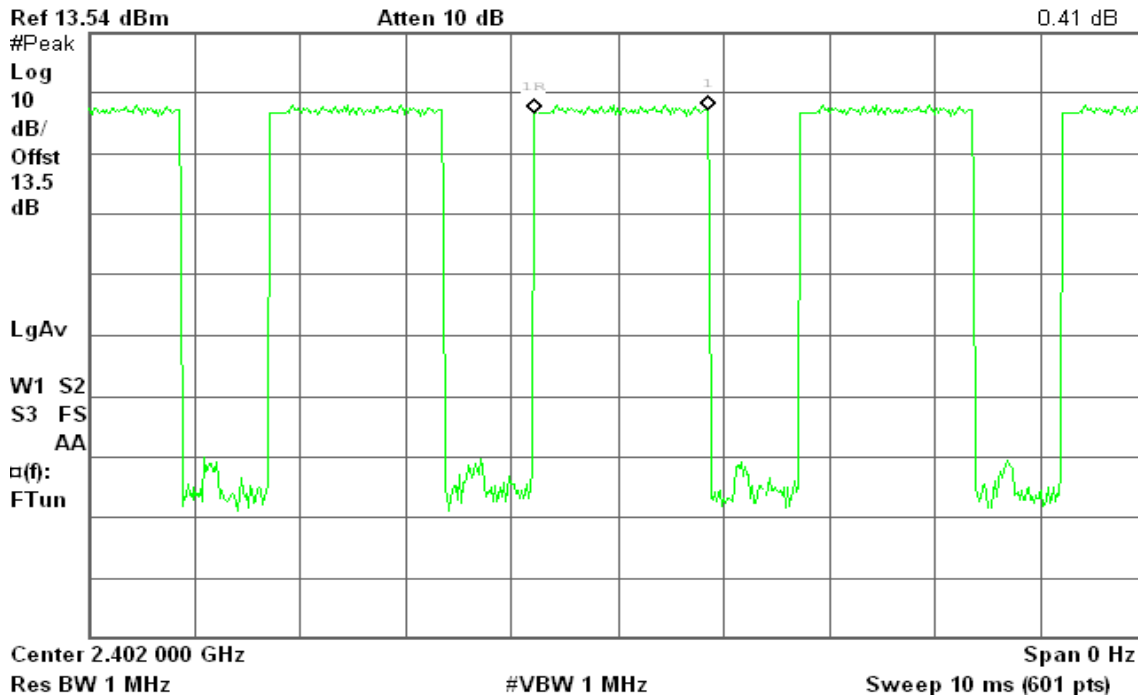



CH Mid

Agilent 14:28:38 Sep 24, 2010

R T

Δ Mkr1 1.633 ms
0.06 dB

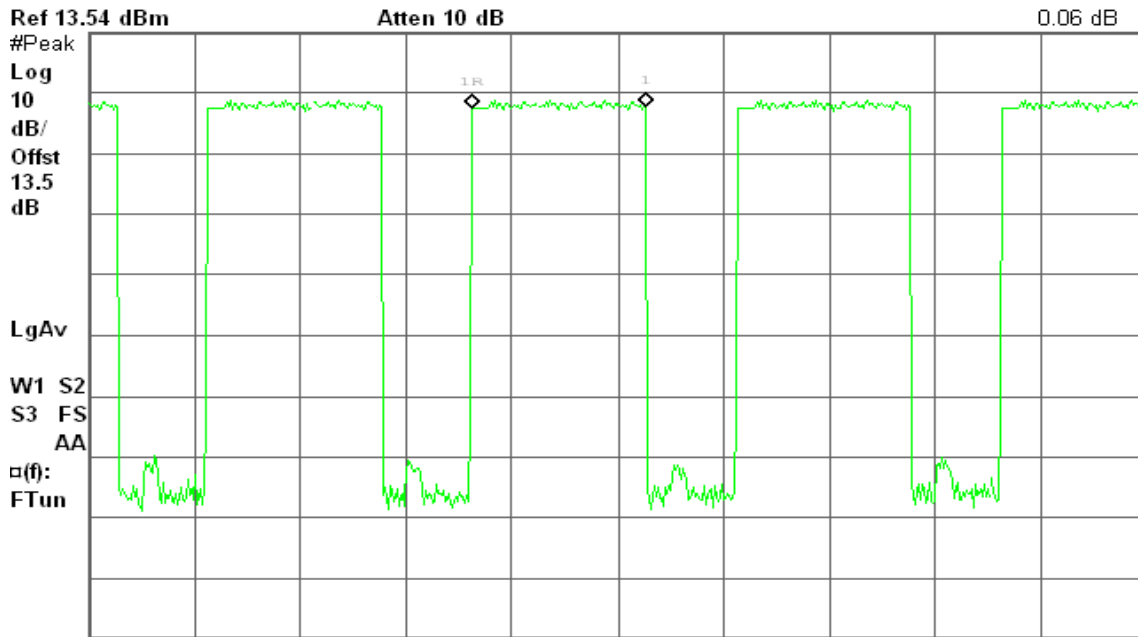

Center 2.441 000 GHz Span 0 Hz
Res BW 1 MHz #VBW 1 MHz Sweep 10 ms (601 pts)

CH High

Agilent 14:35:20 Sep 24, 2010

R T

Δ Mkr1 1.633 ms
0.10 dB

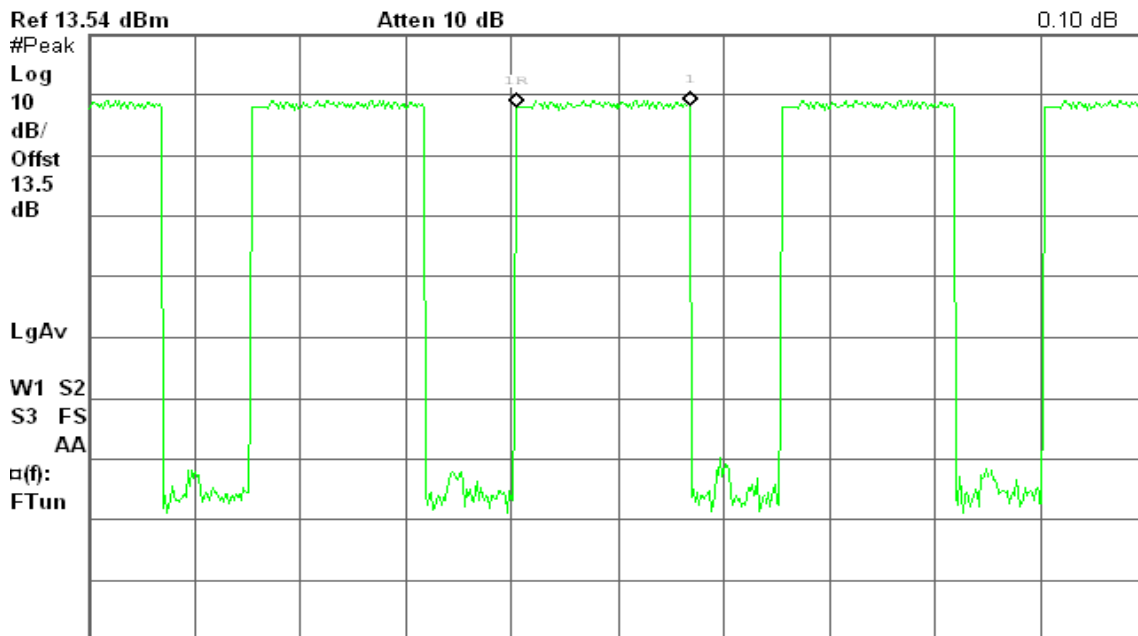

Center 2.480 000 GHz Span 0 Hz
Res BW 1 MHz #VBW 1 MHz Sweep 10 ms (601 pts)



DH 5

CH Low

Agilent 14:25:15 Sep 24, 2010

R T

Δ Mkr1 2.883 ms
0.76 dB

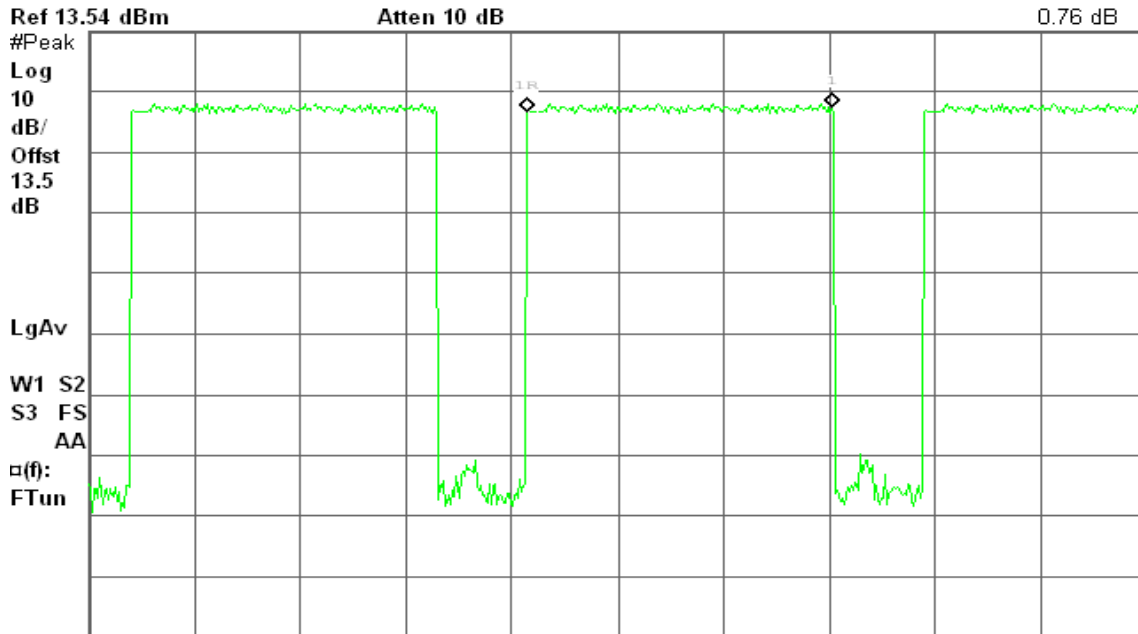

CH Mid

Agilent 14:29:55 Sep 24, 2010

R T

Δ Mkr1 2.883 ms
-0.04 dB

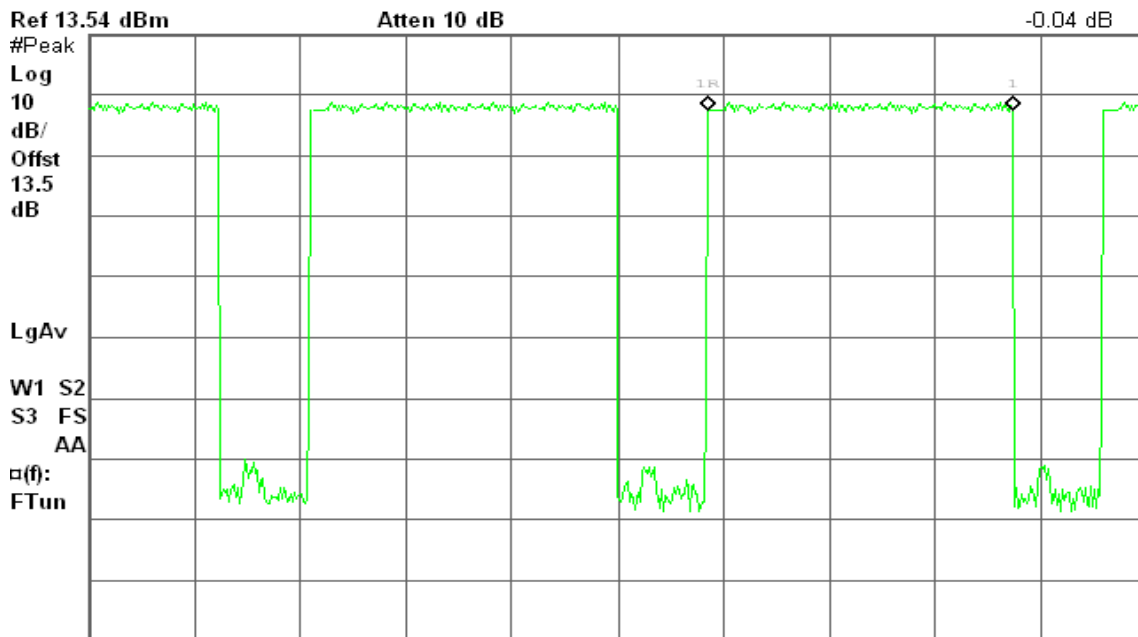



7.8 SPURIOUS EMISSIONS

7.8.1 Conducted Measurement

LIMIT

According to §15.247(d), in any 100 kHz bandwidth outside the frequency bands in which the spread spectrum intentional radiator is operating, the radio frequency power that is produced by the intentional radiator shall be at least 20 dB below that in the 100 kHz bandwidth within the band that contains the highest level of the desired power, based on either an RF conducted or a radiated measurement, provided the transmitter demonstrates compliance with the peak conducted power limits. In addition, radiated emissions which fall in the restricted bands, as defined in §15.205(a), must also comply with the radiated emission limits specified in 15.209(a) (see Section 15.205(c)).

Test Configuration

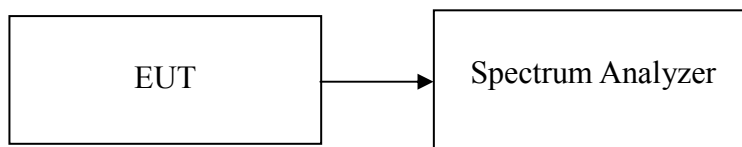

TEST PROCEDURE

Conducted RF measurements of the transmitter output were made to confirm that the EUT antenna port conducted emissions meet the specified limit and to identify any spurious signals that require further investigation or measurements on the radiated emissions site.

The transmitter output is connected to the spectrum analyzer. The resolution bandwidth is set to 100 kHz. The video bandwidth is set to 100 kHz.

Measurements are made over the 30MHz to 26GHz range with the transmitter set to the lowest, middle, and highest channels.

TEST RESULTS

No non-compliance noted



Test Plot

For GFSK / DH5

CH Low

Agilent 13:32:09 Sep 24, 2010

R T

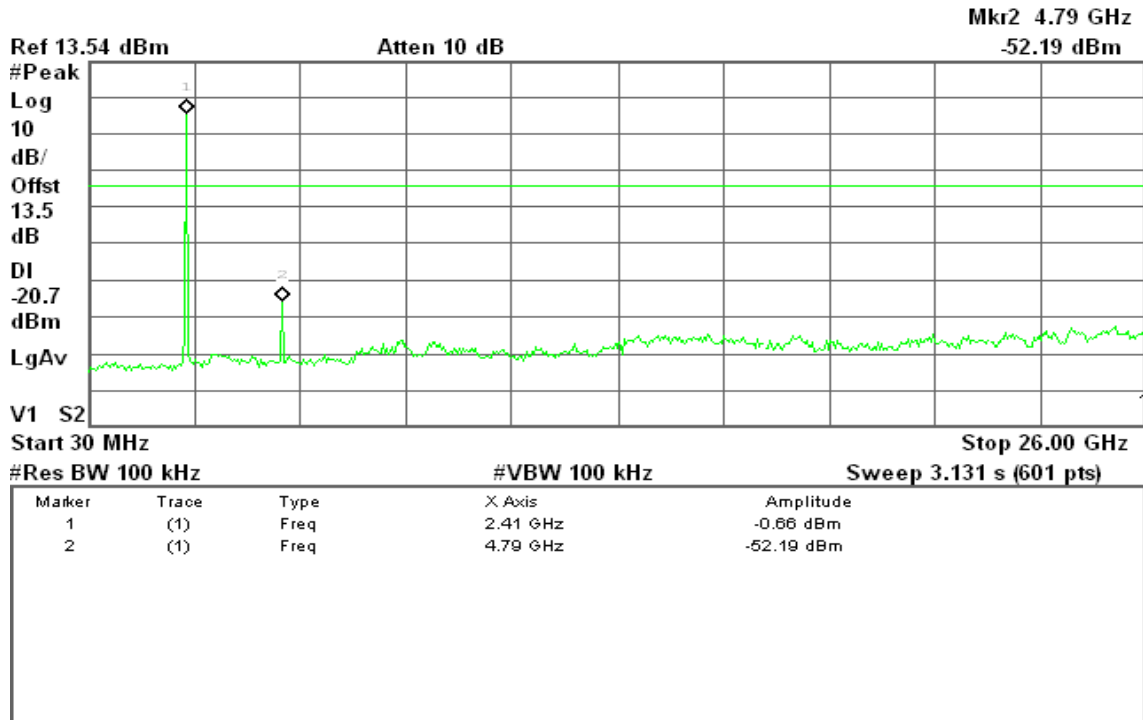

CH Mid

Agilent 13:31:02 Sep 24, 2010

R T

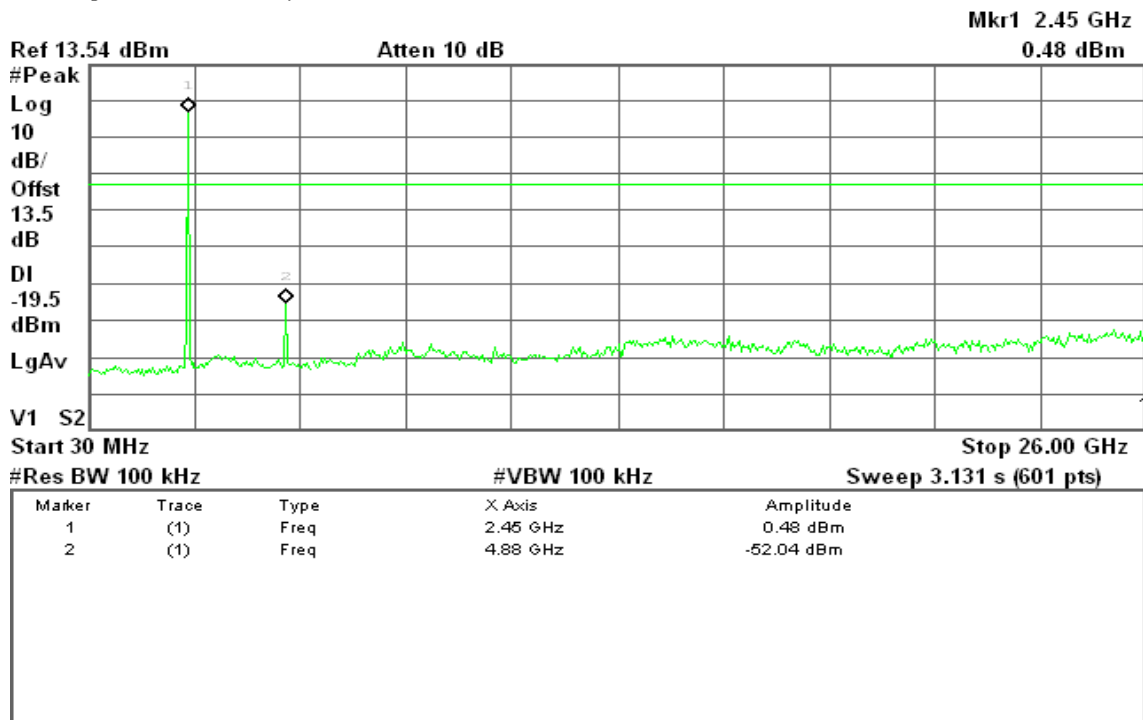



CH High

Agilent 13:29:15 Sep 24, 2010

R T

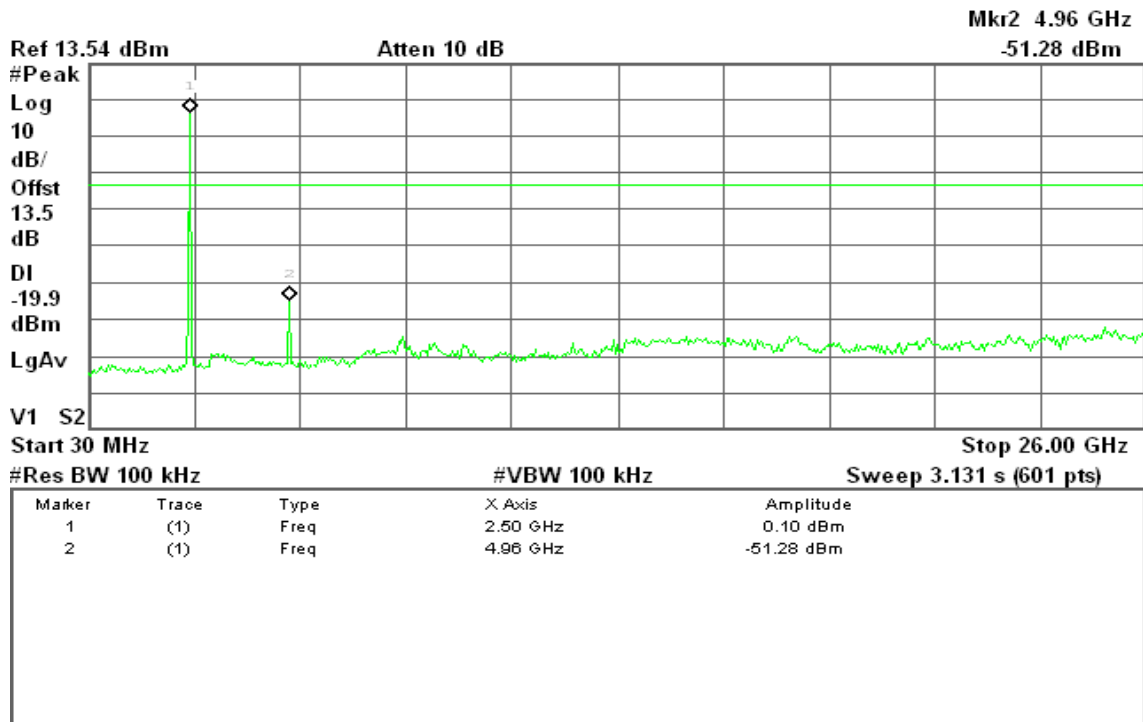



For 8DPSK / DH5

CH Low

Agilent 15:16:40 Sep 24, 2010

R T

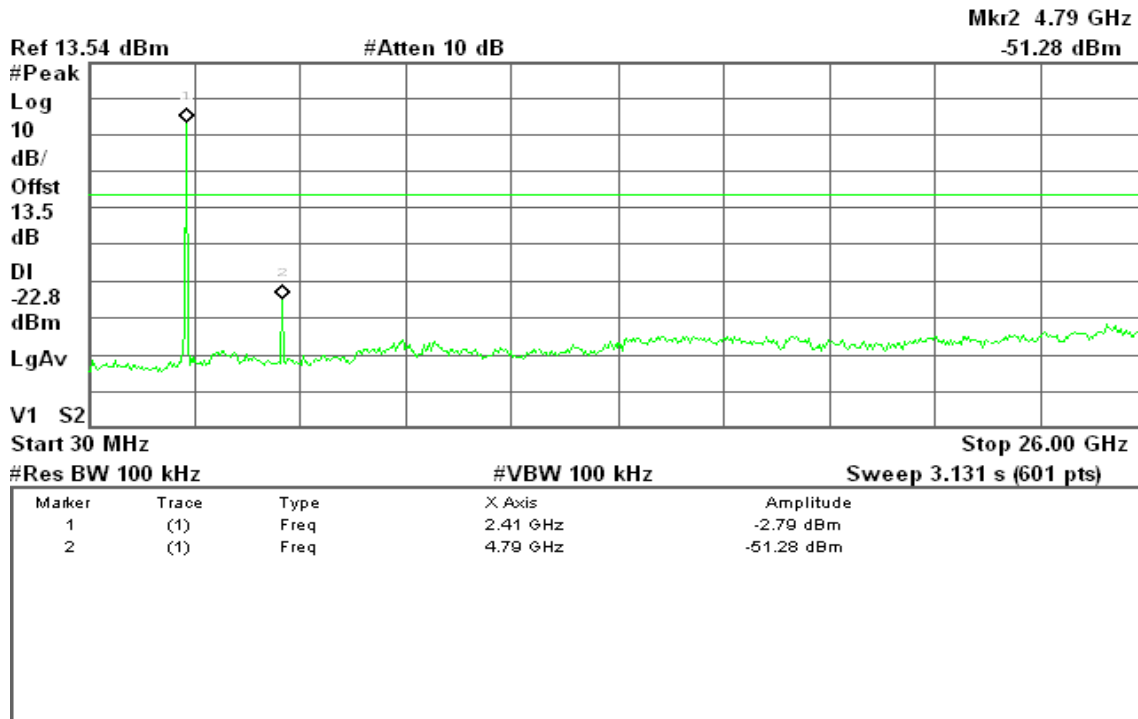

CH Mid

Agilent 14:47:16 Sep 24, 2010

R T

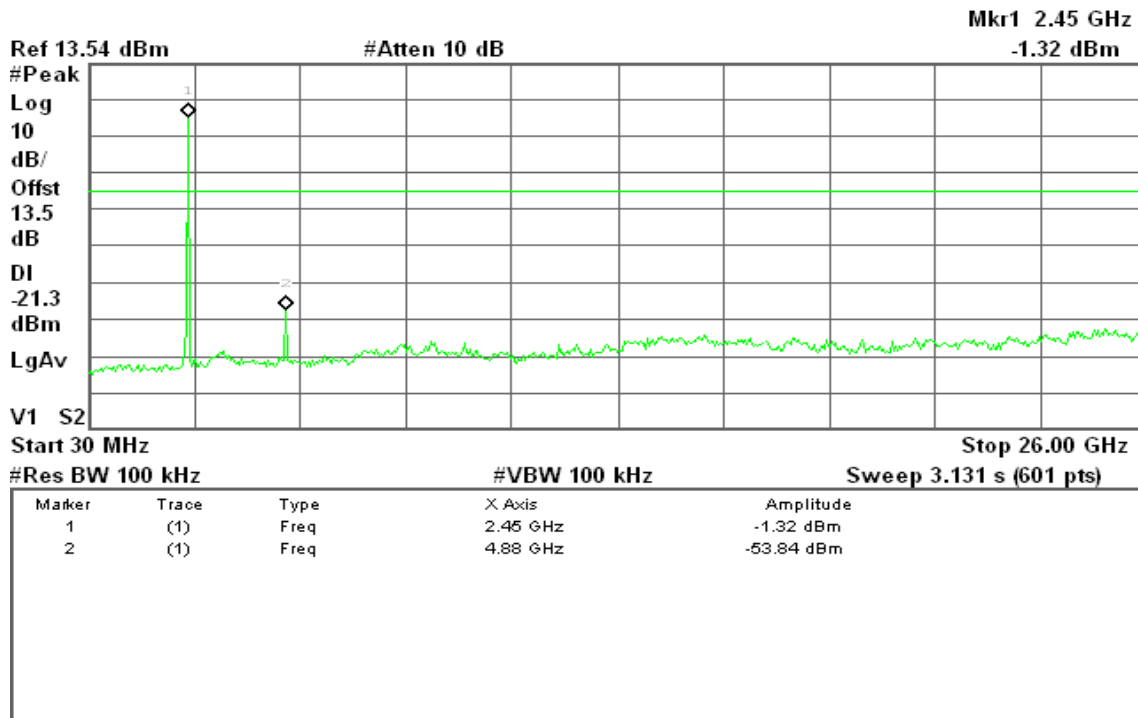



CH High

Agilent 14:45:37 Sep 24, 2010

R T

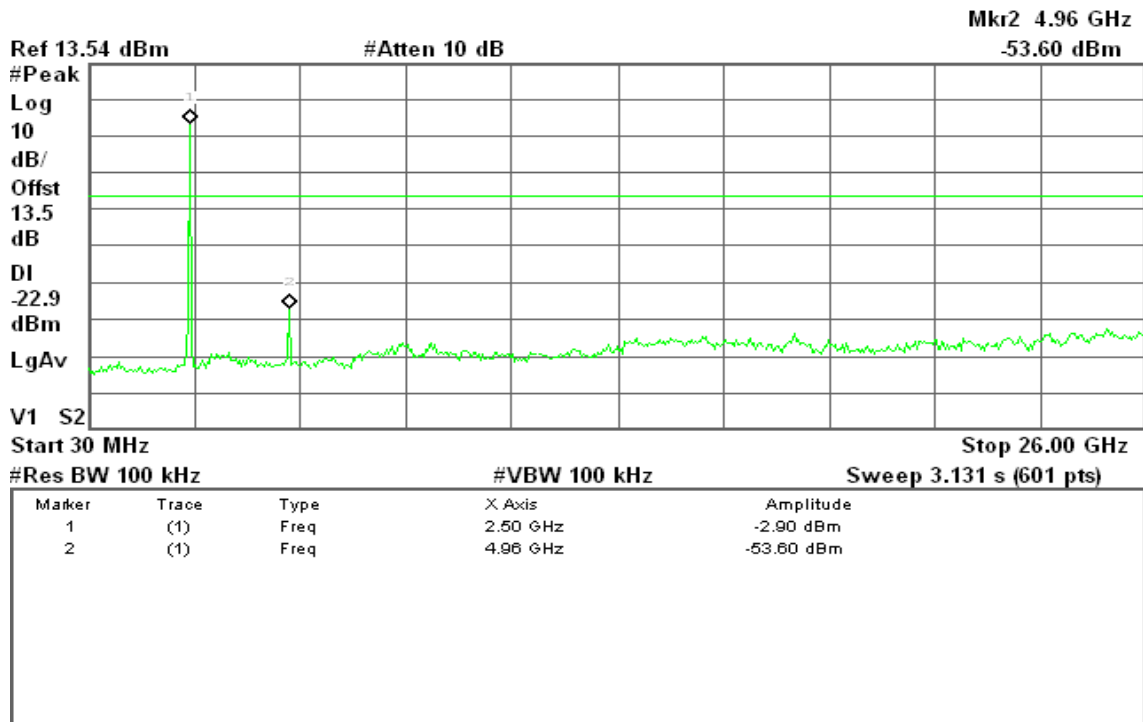



7.8.2 Radiated Emissions

LIMIT

1. According to §15.209(a), except as provided elsewhere in this Subpart, the emissions from an intentional radiator shall not exceed the field strength levels specified in the following table:

Frequency (MHz)	Field Strength ($\mu\text{V}/\text{m}$)	Measurement Distance (m)
30-88	100*	3
88-216	150*	3
216-960	200*	3
Above 960	500	3

Remark: Except as provided in paragraph (g), fundamental emissions from intentional radiators operating under this Section shall not be located in the frequency bands 54-72 MHz, 76-88 MHz, 174-216 MHz or 470-806 MHz. However, operation within these frequency bands is permitted under other sections of this Part, e.g., Sections 15.231 and 15.241.

2. In the emission table above, the tighter limit applies at the band edges.

Frequency (MHz)	Field Strength ($\mu\text{V}/\text{m}$ at 3-meter)	Field Strength (dB $\mu\text{V}/\text{m}$ at 3-meter)
30-88	100	40
88-216	150	43.5
216-960	200	46
Above 960	500	54



Test Configuration

9kHz ~ 30MHz

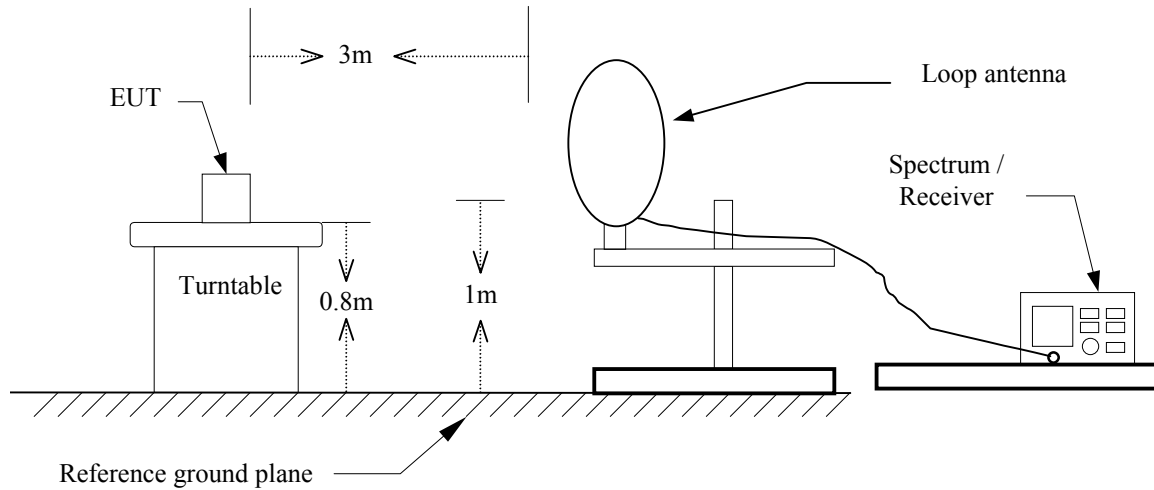

30MHz ~ 1GHz

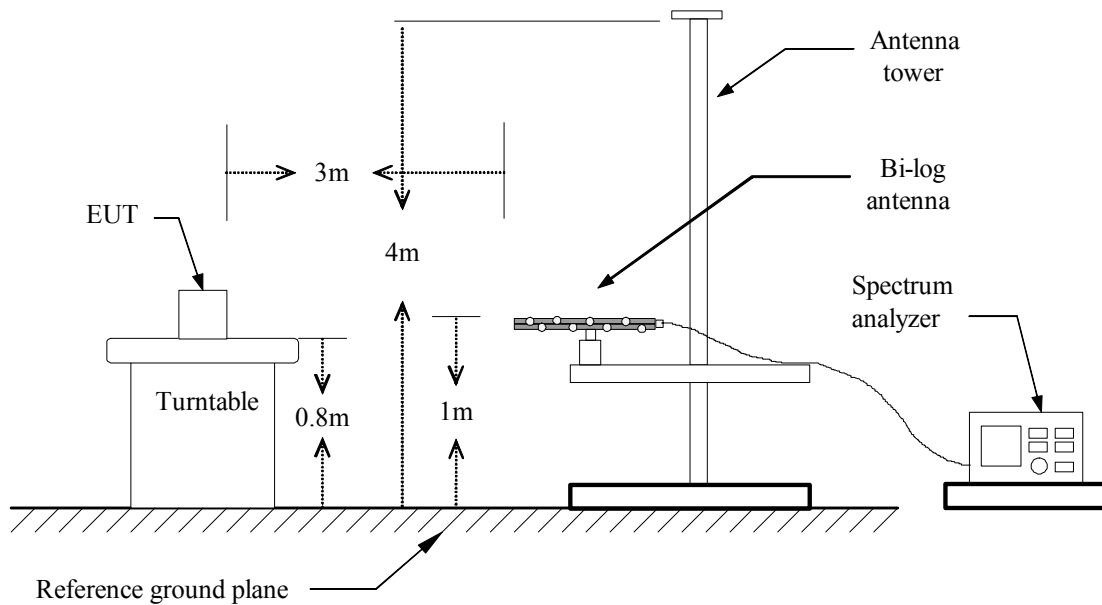



Above 1 GHz

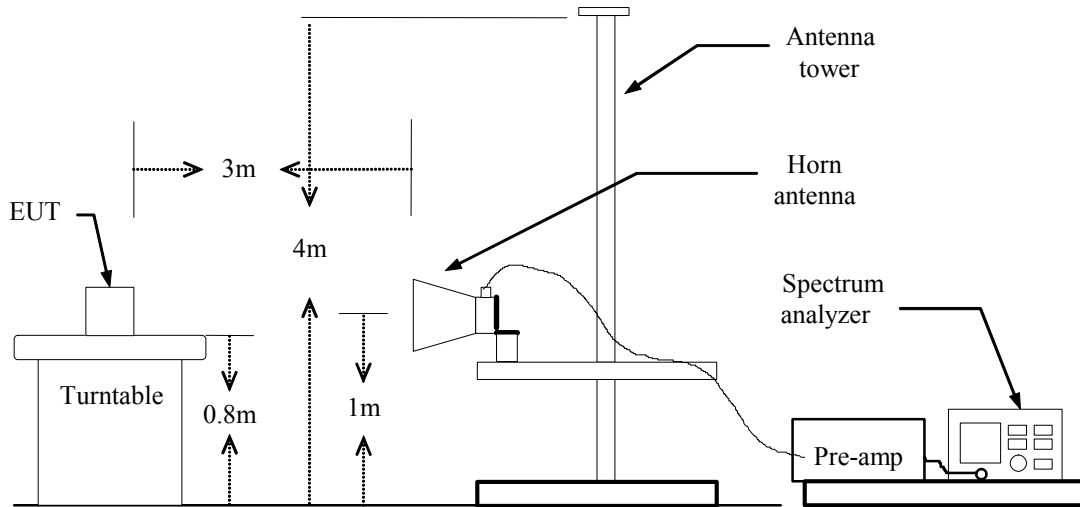



TEST PROCEDURE

1. The EUT is placed on a turntable, which is 0.8m above ground plane.
2. The turntable shall be rotated for 360 degrees to determine the position of maximum emission level.
3. EUT is set 3m away from the receiving antenna, which is varied from 1m to 4m to find out the highest emissions.
4. Maximum procedure was performed on the six highest emissions to ensure EUT compliance.
5. And also, each emission was to be maximized by changing the polarization of receiving antenna both horizontal and vertical.
6. Set the spectrum analyzer in the following setting as:
Below 1GHz:
RBW=100kHz / VBW=300kHz / Sweep=AUTO
Above 1GHz:
(a) PEAK: RBW=VBW=1MHz / Sweep=AUTO
(b) AVERAGE: RBW=1MHz / VBW=10Hz / Sweep=AUTO
7. Repeat above procedures until the measurements for all frequencies are complete.



Below 1 GHz

Operation Mode: Normal Link

Test Date: September 16, 2010

Temperature: 20°C

Tested by: Tom Jen

Humidity: 30% RH

Polarity: Ver. / Hor.

Frequency (MHz)	Ant.Pol. (H/V)	Reading (dBuV)	Correction Factor (dB/m)	Result (dBuV/m)	Limit (dBuV/m)	Margin (dB)	Remark
30.00	V	33.11	-1.86	31.25	40.00	-8.75	Peak
144.78	V	43.33	-10.06	33.27	43.50	-10.23	Peak
175.50	V	45.71	-11.39	34.33	43.50	-9.17	Peak
398.60	V	38.93	-7.12	31.81	46.00	-14.19	Peak
647.57	V	35.72	-2.95	32.77	46.00	-13.23	Peak
945.03	V	35.74	0.22	35.96	46.00	-10.04	Peak
33.23	H	31.36	-4.19	27.17	40.00	-12.83	Peak
211.07	H	41.14	-10.78	30.37	43.50	-13.13	Peak
314.53	H	45.62	-8.89	36.73	46.00	-9.27	Peak
384.05	H	40.05	-7.40	32.65	46.00	-13.35	Peak
689.60	H	36.48	-2.61	33.86	46.00	-12.14	Peak
945.03	H	34.74	0.22	34.97	46.00	-11.03	Peak

Remark:

1. No emission found between lowest internal used/generated frequency to 30MHz (9kHz~30MHz).
2. Radiated emissions measured were made with an instrument using peak/quasi-peak detector mode.
3. Quasi-peak test would be performed if the peak result were greater than the quasi-peak limit or as required by the applicant.
4. Measurements above show only up to 6 maximum emissions noted, or would be lesser, with " N/A " remark, if no specific emissions from the EUT are recorded (ie: margin>20dB from the applicable limit) and considered that's already beyond the background noise floor.
5. Margin (dB) = Remark result (dBuV/m) – Quasi-peak limit (dBuV/m).



Above 1 GHz

Operation Mode: TX / GFSK / DH5 / CH Low

Test Date: September 23, 2010

Temperature: 25°C

Tested by: Mark Yang

Humidity: 55% RH

Polarity: Ver. / Hor.

Frequency (MHz)	Ant.Pol. (H/V)	Reading (Peak) (dBuV)	Reading (Average) (dBuV)	Correction Factor (dB/m)	Result (Peak) (dBuV/m)	Result (Average) (dBuV/m)	Limit (Peak) (dBuV/m)	Limit (Average) (dBuV/m)	Margin (dB)	Remark
1143.33	V	61.22	---	-9.35	51.87	---	74.00	54.00	-2.13	Peak
1660.00	V	62.13	44.80	-7.28	54.85	37.52	74.00	54.00	-16.48	AVG
2180.00	V	58.12	44.25	-3.61	54.51	40.64	74.00	54.00	-13.36	AVG
2333.33	V	58.10	43.17	-3.16	54.94	40.01	74.00	54.00	-13.99	AVG
2493.33	V	58.10	44.80	-2.68	55.42	42.12	74.00	54.00	-11.88	AVG
4808.33	V	50.02	---	1.18	51.20	---	74.00	54.00	-2.80	Peak
1896.67	H	55.45	---	-5.10	50.35	---	74.00	54.00	-3.65	Peak
2093.33	H	58.32	41.75	-3.87	54.45	37.88	74.00	54.00	-16.12	AVG
2493.33	H	58.25	42.50	-2.68	55.57	39.82	74.00	54.00	-14.18	AVG
4808.33	H	54.35	43.97	1.18	55.53	45.15	74.00	54.00	-8.85	AVG
4975.00	H	53.17	42.10	1.13	54.30	43.23	74.00	54.00	-10.77	AVG
N/A										

Remark:

1. Measuring frequencies from 1 GHz to the 10th harmonic of highest fundamental frequency.
2. Radiated emissions measured in frequency above 1000MHz were made with an instrument using peak/average detector mode.
3. Average test would be performed if the peak result were greater than the average limit or as required by the applicant.
4. Data of measurement within this frequency range shown " --- " in the table above means the reading of emissions are attenuated more than 20dB below the permissible limits or the field strength is too small to be measured.
5. Measurements above show only up to 6 maximum emissions noted, or would be lesser, with " N/A " remark, if no specific emissions from the EUT are recorded (ie: margin > 20dB from the applicable limit) and considered that's already beyond the background noise floor.
6. Margin (dB) = Remark result (dBuV/m) – Average limit (dBuV/m).



Operation Mode: TX / GFSK / DH5 / CH Mid

Test Date: September 23, 2010

Temperature: 25°C

Tested by: Mark Yang

Humidity: 55% RH

Polarity: Ver. / Hor.

Frequency (MHz)	Ant.Pol. (H/V)	Reading (Peak) (dBuV)	Reading (Average) (dBuV)	Correction Factor (dB/m)	Result (Peak) (dBuV/m)	Result (Average) (dBuV/m)	Limit (Peak) (dBuV/m)	Limit (Average) (dBuV/m)	Margin (dB)	Remark
1123.33	V	60.82	---	-9.39	51.44	---	74.00	54.00	-2.56	Peak
1156.67	V	64.15	42.30	-9.33	54.82	32.97	74.00	54.00	-21.03	AVG
1653.33	V	57.37	---	-7.35	50.02	---	74.00	54.00	-3.98	Peak
2500.00	V	57.80	43.10	-2.66	55.14	40.44	74.00	54.00	-13.56	AVG
4883.33	V	53.15	42.76	1.16	54.31	43.92	74.00	54.00	-10.08	AVG
N/A										
1890.00	H	56.98	---	-5.16	51.82	---	74.00	54.00	-2.18	Peak
2490.00	H	59.19	42.80	-2.69	56.50	40.11	74.00	54.00	-13.89	AVG
4883.33	H	54.30	43.57	1.16	55.46	44.73	74.00	54.00	-9.27	AVG
4983.33	H	53.08	42.13	1.13	54.21	43.26	74.00	54.00	-10.74	AVG
N/A										

Remark:

1. Measuring frequencies from 1 GHz to the 10th harmonic of highest fundamental frequency.
2. Radiated emissions measured in frequency above 1000MHz were made with an instrument using peak/average detector mode.
3. Average test would be performed if the peak result were greater than the average limit or as required by the applicant.
4. Data of measurement within this frequency range shown " --- " in the table above means the reading of emissions are attenuated more than 20dB below the permissible limits or the field strength is too small to be measured.
5. Measurements above show only up to 6 maximum emissions noted, or would be lesser; with " N/A " remark, if no specific emissions from the EUT are recorded (ie: margin > 20dB from the applicable limit) and considered that's already beyond the background noise floor.
6. Margin (dB) = Remark result (dBuV/m) – Average limit (dBuV/m).



Operation Mode: TX / GFSK / DH5 / CH High

Test Date: September 23, 2010

Temperature: 25°C

Tested by: Mark Yang

Humidity: 55% RH

Polarity: Ver. / Hor.

Frequency (MHz)	Ant.Pol. (H/V)	Reading (Peak) (dBuV)	Reading (Average) (dBuV)	Correction Factor (dB/m)	Result (Peak) (dBuV/m)	Result (Average) (dBuV/m)	Limit (Peak) (dBuV/m)	Limit (Average) (dBuV/m)	Margin (dB)	Remark
1096.67	V	59.92	---	-9.43	50.49	---	74.00	54.00	-3.51	Peak
4958.33	V	52.21	45.66	1.13	53.35	46.79	74.00	54.00	-7.21	AVG
N/A										
1900.00	H	56.28	---	-5.07	51.20	---	74.00	54.00	-2.80	Peak
2496.67	H	58.43	43.10	-2.67	55.76	40.43	74.00	54.00	-13.57	AVG
4958.33	H	53.07	43.73	1.13	54.20	44.86	74.00	54.00	-9.14	AVG
5000.00	H	53.36	44.09	1.12	54.48	45.21	74.00	54.00	-8.79	AVG
N/A										

Remark:

1. Measuring frequencies from 1 GHz to the 10th harmonic of highest fundamental frequency.
2. Radiated emissions measured in frequency above 1000MHz were made with an instrument using peak/average detector mode.
3. Average test would be performed if the peak result were greater than the average limit or as required by the applicant.
4. Data of measurement within this frequency range shown " --- " in the table above means the reading of emissions are attenuated more than 20dB below the permissible limits or the field strength is too small to be measured.
5. Measurements above show only up to 6 maximum emissions noted, or would be lesser; with " N/A " remark, if no specific emissions from the EUT are recorded (ie: margin>20dB from the applicable limit) and considered that's already beyond the background noise floor.
6. Margin (dB) = Remark result (dBuV/m) – Average limit (dBuV/m).



Operation Mode: TX / 8DPSK / DH5 / CH Low

Test Date: September 23, 2010

Temperature: 25°C

Tested by: Mark Yang

Humidity: 55% RH

Polarity: Ver. / Hor.

Frequency (MHz)	Ant.Pol. (H/V)	Reading (Peak) (dBuV)	Reading (Average) (dBuV)	Correction Factor (dB/m)	Result (Peak) (dBuV/m)	Result (Average) (dBuV/m)	Limit (Peak) (dBuV/m)	Limit (Average) (dBuV/m)	Margin (dB)	Remark
1120.00	V	58.42	---	-9.39	49.03	---	74.00	54.00	-4.97	Peak
1670.00	V	56.41	---	-7.19	49.22	---	74.00	54.00	-4.78	Peak
N/A										
1896.67	H	56.54	---	-5.10	51.43	---	74.00	54.00	-2.57	Peak
2496.67	H	59.04	43.10	-2.67	56.37	40.43	74.00	54.00	-13.57	AVG
4800.00	H	53.17	43.02	1.18	54.35	44.20	74.00	54.00	-9.80	AVG
5000.00	H	52.90	42.03	1.12	54.02	43.15	74.00	54.00	-10.85	AVG
N/A										

Remark:

1. Measuring frequencies from 1 GHz to the 10th harmonic of highest fundamental frequency.
2. Radiated emissions measured in frequency above 1000MHz were made with an instrument using peak/average detector mode.
3. Average test would be performed if the peak result were greater than the average limit or as required by the applicant.
4. Data of measurement within this frequency range shown “ --- ” in the table above means the reading of emissions are attenuated more than 20dB below the permissible limits or the field strength is too small to be measured.
5. Measurements above show only up to 6 maximum emissions noted, or would be lesser; with “ N/A ” remark, if no specific emissions from the EUT are recorded (ie: margin>20dB from the applicable limit) and considered that's already beyond the background noise floor.
6. Margin (dB) = Remark result (dBuV/m) – Average limit (dBuV/m).



Operation Mode: TX / 8DPSK / DH5 / CH Mid

Test Date: September 23, 2010

Temperature: 25°C

Tested by: Mark Yang

Humidity: 55% RH

Polarity: Ver. / Hor.

Frequency (MHz)	Ant.Pol. (H/V)	Reading (Peak) (dBuV)	Reading (Average) (dBuV)	Correction Factor (dB/m)	Result (Peak) (dBuV/m)	Result (Average) (dBuV/m)	Limit (Peak) (dBuV/m)	Limit (Average) (dBuV/m)	Margin (dB)	Remark
1896.67	V	55.61	---	-5.10	50.50	---	74.00	54.00	-3.50	Peak
2493.33	V	57.37	42.53	-2.68	54.69	39.85	74.00	54.00	-14.15	AVG
4883.33	V	50.23	---	1.16	51.39	---	74.00	54.00	-2.61	Peak
N/A										
2093.33	H	54.59	---	-3.87	50.72	---	74.00	54.00	-3.28	Peak
2486.67	H	57.82	46.80	-2.70	55.12	44.10	74.00	54.00	-9.90	AVG
4883.33	H	54.80	44.01	1.16	55.96	45.17	74.00	54.00	-8.83	AVG
4975.00	H	53.21	42.37	1.13	54.34	43.50	74.00	54.00	-10.50	AVG
N/A										

Remark:

1. Measuring frequencies from 1 GHz to the 10th harmonic of highest fundamental frequency.
2. Radiated emissions measured in frequency above 1000MHz were made with an instrument using peak/average detector mode.
3. Average test would be performed if the peak result were greater than the average limit or as required by the applicant.
4. Data of measurement within this frequency range shown " --- " in the table above means the reading of emissions are attenuated more than 20dB below the permissible limits or the field strength is too small to be measured.
5. Measurements above show only up to 6 maximum emissions noted, or would be lesser; with " N/A " remark, if no specific emissions from the EUT are recorded (ie: margin>20dB from the applicable limit) and considered that's already beyond the background noise floor.
6. Margin (dB) = Remark result (dBuV/m) – Average limit (dBuV/m).



Operation Mode: TX / 8DPSK / DH5 / CH High

Test Date: September 23, 2010

Temperature: 25°C

Tested by: Mark Yang

Humidity: 55% RH

Polarity: Ver. / Hor.

Frequency (MHz)	Ant.Pol. (H/V)	Reading (Peak) (dBuV)	Reading (Average) (dBuV)	Correction Factor (dB/m)	Result (Peak) (dBuV/m)	Result (Average) (dBuV/m)	Limit (Peak) (dBuV/m)	Limit (Average) (dBuV/m)	Margin (dB)	Remark
1756.67	V	55.08	---	-6.39	48.69	---	74.00	54.00	-5.31	Peak
4958.33	V	53.73	44.27	1.13	54.86	45.40	74.00	54.00	-8.60	AVG
N/A										
1893.33	H	55.71	---	-5.13	50.58	---	74.00	54.00	-3.42	Peak
2500.00	H	57.51	45.80	-2.66	54.85	43.14	74.00	54.00	-10.86	AVG
4958.33	H	54.20	44.72	1.13	55.33	45.85	74.00	54.00	-8.15	AVG
4975.00	H	53.10	42.15	1.13	54.23	43.28	74.00	54.00	-10.72	AVG
N/A										

Remark:

1. Measuring frequencies from 1 GHz to the 10th harmonic of highest fundamental frequency.
2. Radiated emissions measured in frequency above 1000MHz were made with an instrument using peak/average detector mode.
3. Average test would be performed if the peak result were greater than the average limit or as required by the applicant.
4. Data of measurement within this frequency range shown “ --- ” in the table above means the reading of emissions are attenuated more than 20dB below the permissible limits or the field strength is too small to be measured.
5. Measurements above show only up to 6 maximum emissions noted, or would be lesser; with “ N/A ” remark, if no specific emissions from the EUT are recorded (ie: margin>20dB from the applicable limit) and considered that's already beyond the background noise floor.
6. Margin (dB) = Remark result (dBuV/m) – Average limit (dBuV/m).



7.9 POWERLINE CONDUCTED EMISSIONS

LIMIT

According to §15.207(a), except as shown in paragraphs (b) and (c) of this section, for an intentional radiator that is designed to be connected to the public utility (AC) power line, the radio frequency voltage that is conducted back onto the AC power line on any frequency or frequencies within the band 150 kHz to 30 MHz shall not exceed the limits in the following table, as measured using a 50 μ H/50 ohms line impedance stabilization network (LISN). Compliance with the provisions of this paragraph shall be based on the measurement of the radio frequency voltage between each power line and ground at the power terminal. The lower limit applies at the boundary between the frequency ranges.

Frequency Range (MHz)	Limits (dB μ V)	
	Quasi-peak	Average
0.15 to 0.50	66 to 56*	56 to 46*
0.50 to 5	56	46
5 to 30	60	50

* Decreases with the logarithm of the frequency.

Test Configuration

See test photographs attached in Appendix II for the actual connections between EUT and support equipment.

TEST PROCEDURE

1. The EUT was placed on a table, which is 0.8m above ground plane.
2. Maximum procedure was performed on the six highest emissions to ensure EUT compliance.
3. Repeat above procedures until all frequency measured were complete.



TEST RESULTS

The initial step in collecting conducted data is a spectrum analyzer peak scan of the measurement range. Significant peaks are then marked as shown on the following data page, and these signals are then quasi-peaked.

Test Data

Operation Mode: Normal Link

Test Date: September 14, 2010

Temperature: 24°C

Tested by: Ryan Huang

Humidity: 60% RH

Freq. (MHz)	QP Reading (dBuV)	AV Reading (dBuV)	Corr. factor (dB)	QP Result (dBuV)	AV Result (dBuV)	QP Limit (dBuV)	AV Limit (dBuV)	QP Margin (dB)	AV Margin (dB)	Note
0.1914	49.02	32.86	10.82	59.84	43.68	63.97	53.97	-4.13	-10.29	L1
0.2540	43.06	29.63	10.79	53.85	40.42	61.62	51.62	-7.77	-11.20	L1
0.3220	38.07	22.55	10.74	48.81	33.29	59.65	49.65	-10.84	-16.36	L1
0.3820	36.21	22.17	10.71	46.92	32.88	58.23	48.23	-11.31	-15.35	L1
18.5380	33.93	22.31	11.11	45.04	33.42	60.00	50.00	-14.96	-16.58	L1
21.6020	30.91	25.15	11.19	42.10	36.34	60.00	50.00	-17.90	-13.66	L1
0.1900	49.67	31.04	10.66	60.33	41.70	64.03	54.03	-3.70	-12.33	L2
0.2500	41.28	30.19	10.64	51.92	40.83	61.75	51.75	-9.83	-10.92	L2
0.3100	37.63	22.23	10.63	48.26	32.86	59.97	49.97	-11.71	-17.11	L2
0.4020	34.22	24.15	10.60	44.82	34.75	57.81	47.81	-12.99	-13.06	L2
18.5459	35.99	22.52	11.05	47.04	33.57	60.00	50.00	-12.96	-16.43	L2
21.6020	31.99	27.11	11.14	43.13	38.25	60.00	50.00	-16.87	-11.75	L2

Remark:

1. Measuring frequencies from 0.15 MHz to 30MHz.
2. The emissions measured in frequency range from 0.15 MHz to 30MHz were made with an instrument using Quasi-peak detector and average detector.
3. The IF bandwidth of SPA between 0.15MHz and 30MHz was 10kHz; the IF bandwidth of Test Receiver between 0.15MHz and 30MHz was 9kHz;
4. L1 = Line One (Live Line) / L2 = Line Two (Neutral Line)



Test Plots

Conducted emissions (Line 1)

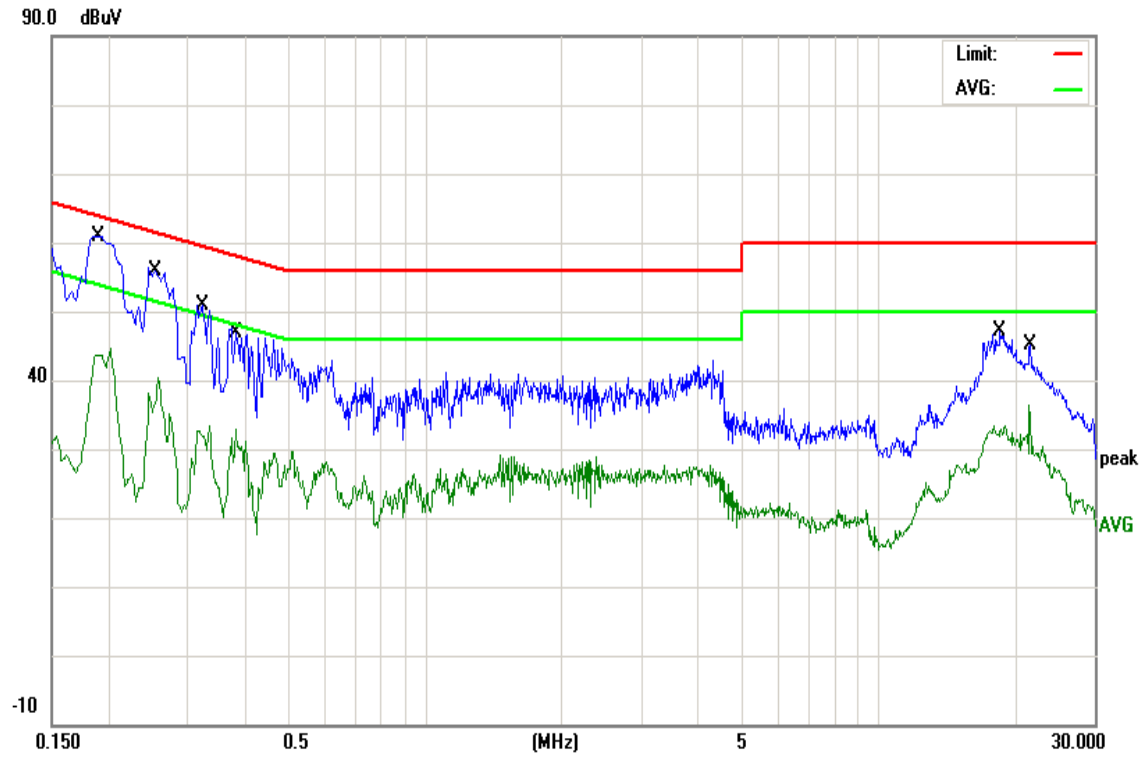

Conducted emissions (Line 2)

