

VTREK		
Design:	Mode:	
Check:	Block:	Rev V0
Approve:	Date: Wednesday, June 01, 2011 Sheet 0 of 0	

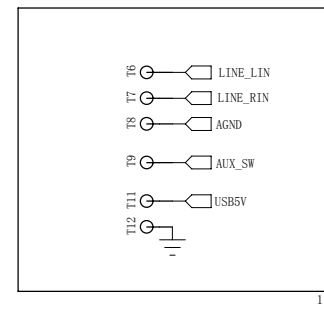

<b>VTREK</b>	
Design:	Mode:
Check:	Block: <span style="float: right;">Rev V0</span>
Approve:	Date: Wednesday, June 01, 2011 Sheet 0 of 0

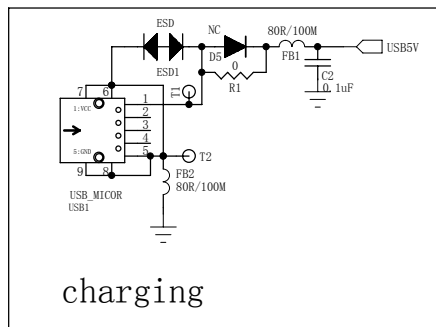
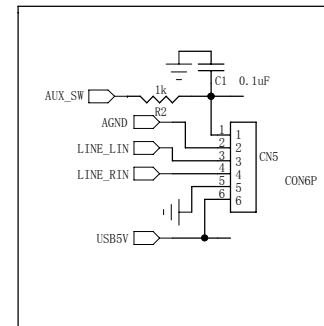
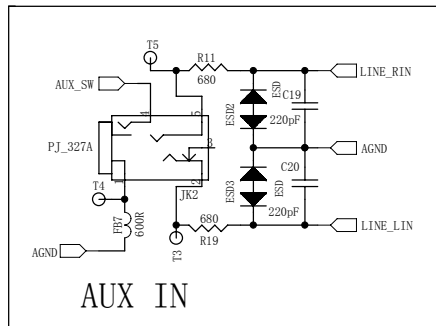
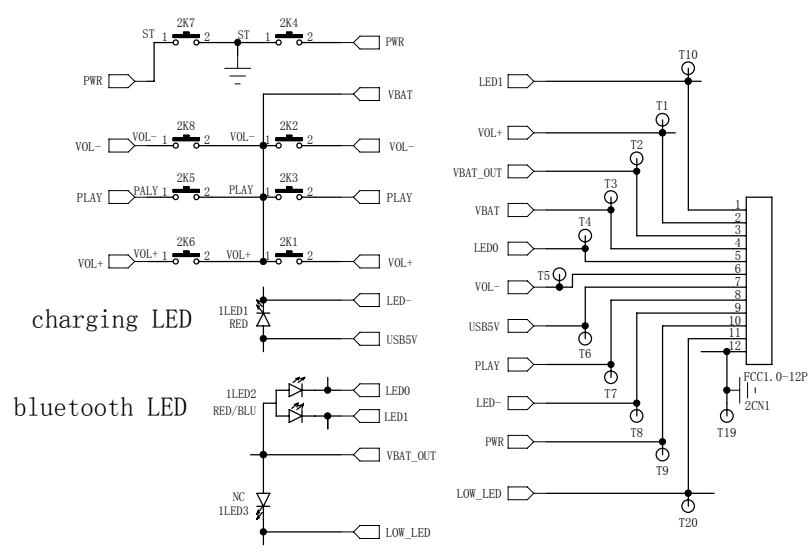

<b>VTREK</b>	
Design:	Mode:
Check:	Block: <span style="float: right;">Rev V0</span>
Approve:	Date: Wednesday, June 01, 2011 Sheet 0 of 0

2402-2480MHz

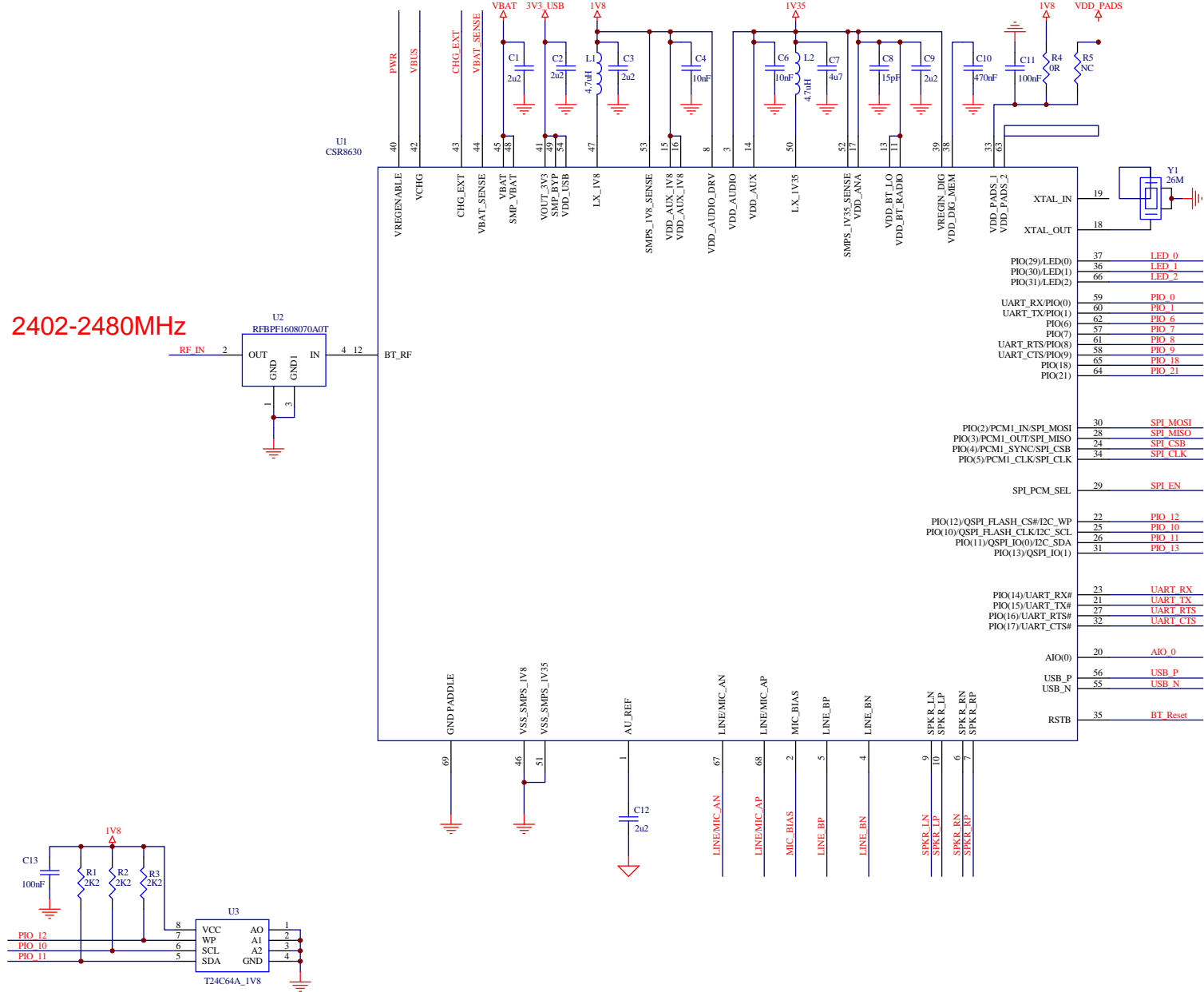

Rev No:V01A		BT		Date:2013-08-04 d
R&D	Drawn:	Checked By:	Appover By:	