

# FCC Radio Test Report

## FCC ID: EROTSW770

**Report No.** : BTL-FCCP-2-1911T045  
**Equipment** : 7 inch Touch Screen wall mount  
**Model Name** : M201923002, TSW-770-B-S, TSW-770-W-S, TSW-770P-B-S,  
TSW-770P-W-S, TSS-770-B-S, TSS-770-W-S  
**Brand Name** : CRESTRON  
**Applicant** : Crestron Electronics, Inc.  
**Address** : 15 Volvo Drive, Rockleigh, NJ 07647

**Radio Function** : Bluetooth Low Energy

**FCC Rule Part(s)** : FCC Part15, Subpart C (15.247)  
**Measurement Procedure(s)** : ANSI C63.10-2013

**Date of Receipt** : 2018/11/28  
**Date of Test** : 2018/11/28 ~ 2019/12/18  
**Issued Date** : 2020/3/24

The above equipment has been tested and found in compliance with the requirement of the above standards by BTL Inc.

**Prepared by** :

  
Peter Chen, Engineer

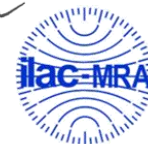

**Approved by** :

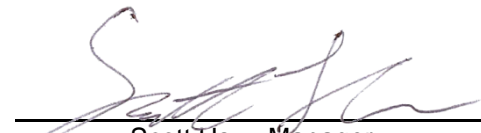
  
Scott Hsu, Manager

**BTL Inc.**

No.18, Ln. 171, Sec. 2, Jiuzong Rd., Neihu Dist., Taipei City 114, Taiwan

Tel: +886-2-2657-3299

Fax: +886-2-2657-3331

Web: [www.newbtl.com](http://www.newbtl.com)

**Declaration**

**BTL** represents to the client that testing is done in accordance with standard procedures as applicable and that test instruments used has been calibrated with standards traceable to international standard(s) and/or national standard(s).

**BTL's** reports apply only to the specific samples tested under conditions. It is manufacture's responsibility to ensure that additional production units of this model are manufactured with the identical electrical and mechanical components. **BTL** shall have no liability for any declarations, inferences or generalizations drawn by the client or others from **BTL** issued reports.

The report must not be used by the client to claim product certification, approval, or endorsement by NIST, A2LA, or any agency of the U.S. Government.

This report is the confidential property of the client. As a mutual protection to the clients, the public and ourselves, the test report shall not be reproduced, except in full, without our written approval.

**BTL's** laboratory quality assurance procedures are in compliance with the **ISO/IEC 17025** requirements, and accredited by the conformity assessment authorities listed in this test report.

**BTL** is not responsible for the sampling stage, so the results only apply to the sample as received.

The information, data and test plan are provided by manufacturer which may affect the validity of results, so it is manufacturer's responsibility to ensure that the apparatus meets the essential requirements of applied standards and in all the possible configurations as representative of its intended use.

**Limitation**

For the use of the authority's logo is limited unless the Test Standard(s)/Scope(s)/Item(s) mentioned in this test report is (are) included in the conformity assessment authorities acceptance respective.

Please note that the measurement uncertainty is provided for informational purpose only and are not use in determining the Pass/Fail results.

**CONTENTS**

REPORT ISSUED HISTORY	5
1 SUMMARY OF TEST RESULTS	6
1.1 TEST FACILITY	7
1.2 MEASUREMENT UNCERTAINTY	7
1.3 TEST ENVIRONMENT CONDITIONS	8
1.4 TABLE OF PARAMETERS OF TEXT SOFTWARE SETTING	8
1.5 DUTY CYCLE	8
2 GENERAL INFORMATION	9
2.1 DESCRIPTION OF EUT	9
2.2 TEST MODES	10
2.3 BLOCK DIAGRAM SHOWING THE CONFIGURATION OF SYSTEM TESTED	11
2.4 SUPPORT UNITS	11
3 RADIATED EMISSIONS TEST	12
3.1 LIMIT	12
3.2 TEST PROCEDURE	13
3.3 DEVIATION FROM TEST STANDARD	13
3.4 TEST SETUP	13
3.5 EUT OPERATING CONDITIONS	14
3.6 TEST RESULT – 9 KHZ TO 30 MHZ	15
3.7 TEST RESULT – 30 MHZ TO 1 GHZ	15
3.8 TEST RESULT – ABOVE 1 GHZ	15
4 BANDWIDTH TEST	16
4.1 APPLIED PROCEDURES / LIMIT	16
4.2 TEST PROCEDURE	16
4.3 DEVIATION FROM STANDARD	16
4.4 TEST SETUP	16
4.5 EUT OPERATION CONDITIONS	16
4.6 TEST RESULTS	16
5 OUTPUT POWER TEST	17
5.1 APPLIED PROCEDURES / LIMIT	17
5.2 TEST PROCEDURE	17
5.3 DEVIATION FROM STANDARD	17
5.4 TEST SETUP	17
5.5 EUT OPERATION CONDITIONS	17
5.6 TEST RESULTS	17
6 POWER SPECTRAL DENSITY TEST	18
6.1 APPLIED PROCEDURES / LIMIT	18
6.2 TEST PROCEDURE	18
6.3 DEVIATION FROM STANDARD	18
6.4 TEST SETUP	18
6.5 EUT OPERATION CONDITIONS	18
6.6 TEST RESULTS	18
7 ANTENNA CONDUCTED SPURIOUS EMISSION	19
7.1 APPLIED PROCEDURES / LIMIT	19
7.2 TEST PROCEDURE	19
7.3 DEVIATION FROM STANDARD	19
7.4 TEST SETUP	19
7.5 EUT OPERATION CONDITIONS	19

7.6	TEST RESULTS	19
8	LIST OF MEASURING EQUIPMENTS	20
9	EUT TEST PHOTO	21
10	EUT PHOTOS	21
APPENDIX A	RADIATED EMISSIONS - 9 KHZ TO 30 MHZ	22
APPENDIX B	RADIATED EMISSIONS - 30 MHZ TO 1 GHZ	27
APPENDIX C	RADIATED EMISSIONS - ABOVE 1 GHZ	30
APPENDIX D	BANDWIDTH	39
APPENDIX E	OUTPUT POWER	41
APPENDIX F	POWER SPECTRAL DENSITY TEST	43
APPENDIX G	ANTENNA CONDUCTED SPURIOUS EMISSION	45

**REPORT ISSUED HISTORY**

Report Version	Description	Issued Date
R00	Original Issue.	2020/1/21
R01	Revised report to address TCB's comments.	2020/3/3
R02	Revised report to address TCB's comments.	2020/3/24

## 1 SUMMARY OF TEST RESULTS

Test procedures according to the technical standards.

FCC Part 15, Subpart C (15.247)				
Standard(s) Section	Description	Test Result	Judgement	Remark
15.207	AC Power Line Conducted Emissions	-----	N/A	NOTE(3)
15.205 15.209 15.247(d)	Radiated Emissions	APPENDIX A APPENDIX B APPENDIX C	Pass	-----
15.247(a)(2)	Bandwidth	APPENDIX D	Pass	-----
15.247(b)(3)	Output Power	APPENDIX E	Pass	-----
15.247(e)	Power Spectral Density	APPENDIX F	Pass	-----
15.247(d)	Antenna conducted Spurious Emission	APPENDIX G	Pass	-----
15.203	Antenna Requirement	-----	Pass	-----

**NOTE:**

- (1) "N/A" denotes test is not applicable in this Test Report.
- (2) The report format version is TP.1.1.1.
- (3) Input power is supplied by POE.

### 1.1 TEST FACILITY

The test facilities used to collect the test data in this report:

No. 68-1, Ln. 169, Sec. 2, Datong Rd., Xizhi Dist., New Taipei City 221, Taiwan

The test sites and facilities are covered under FCC RN: 355421 and DN: TW1099.

- C05       CB08       CB11       CB15       CB16  
 SR06

No.18, Ln. 171, Sec. 2, Jiuzong Rd., Neihu Dist., Taipei City 114, Taiwan

The test sites and facilities are covered under FCC RN: 325517 and DN: TW1115.

- C03       CB18       CB19

### 1.2 MEASUREMENT UNCERTAINTY

The reported uncertainty of measurement  $y \pm U$ , where expanded uncertainty  $U$  is based on a standard uncertainty multiplied by a coverage factor of  $k = 2$ , providing a level of confidence of approximately **95 %**. The measurement instrumentation uncertainty considerations contained in CISPR 16-4-2. The BTL measurement uncertainty is less than the CISPR 16-4-2  $U_{cispr}$  requirement.

#### A. Radiated emissions below 1 GHz test :

Test Site	Method	Measurement Frequency Range	Ant. H / V	U,(dB)
CB18 (3m)	CISPR	30MHz ~ 200MHz	V	4.20
		30MHz ~ 200MHz	H	3.64
		200MHz ~ 1,000MHz	V	4.56
		200MHz ~ 1,000MHz	H	3.90

#### B. Radiated emissions above 1 GHz test :

Test Site	Method	Measurement Frequency Range	Ant. H / V	U,(dB)
CB18 (3m)	CISPR	1GHz ~ 6GHz	V	4.46
		1GHz ~ 6GHz	H	4.40
		6GHz ~ 18GHz	V	3.88
		6GHz ~ 18GHz	H	4.00

Test Site	Method	Measurement Frequency Range	U,(dB)
CB18 (1m)	CISPR	18 ~ 26.5 GHz	4.62
		26.5 ~ 40 GHz	5.12

#### C. Conducted test :

Test Item	U,(dB)
Bandwidth	1.13
Output power	1.06
Power Spectral Density	1.20
Conducted Spurious emissions	1.14
Conducted Band edges	1.13

#### NOTE:

Unless specifically mentioned, the uncertainty of measurement has not been taken into account to declare the compliance or non-compliance to the specification.

### 1.3 TEST ENVIRONMENT CONDITIONS

Test Item	Environment Condition	Tested by
Radiated emissions below 1 GHz	23 °C, 65 %	Hunter Chiang
Radiated emissions above 1 GHz	23 °C, 65 %	Hunter Chiang
Bandwidth	24.5 °C, 54.3 %	Jay Kao
Output Power	24.5 °C, 54.3 %	Jay Kao
Power Spectral Density	24.5 °C, 54.3 %	Jay Kao
Antenna conducted Spurious Emission	24.5 °C, 54.3 %	Jay Kao

### 1.4 TABLE OF PARAMETERS OF TEXT SOFTWARE SETTING

Test Software	QRCT4			
Modulation Mode	2402 MHz	2440 MHz	2480 MHz	Data Rate
GFSK	DEF	DEF	DEF	1 Mbps

### 1.5 DUTY CYCLE

If duty cycle is  $\geq 98\%$ , duty factor is not required.  
 If duty cycle is  $< 98\%$ , duty factor shall be considered.

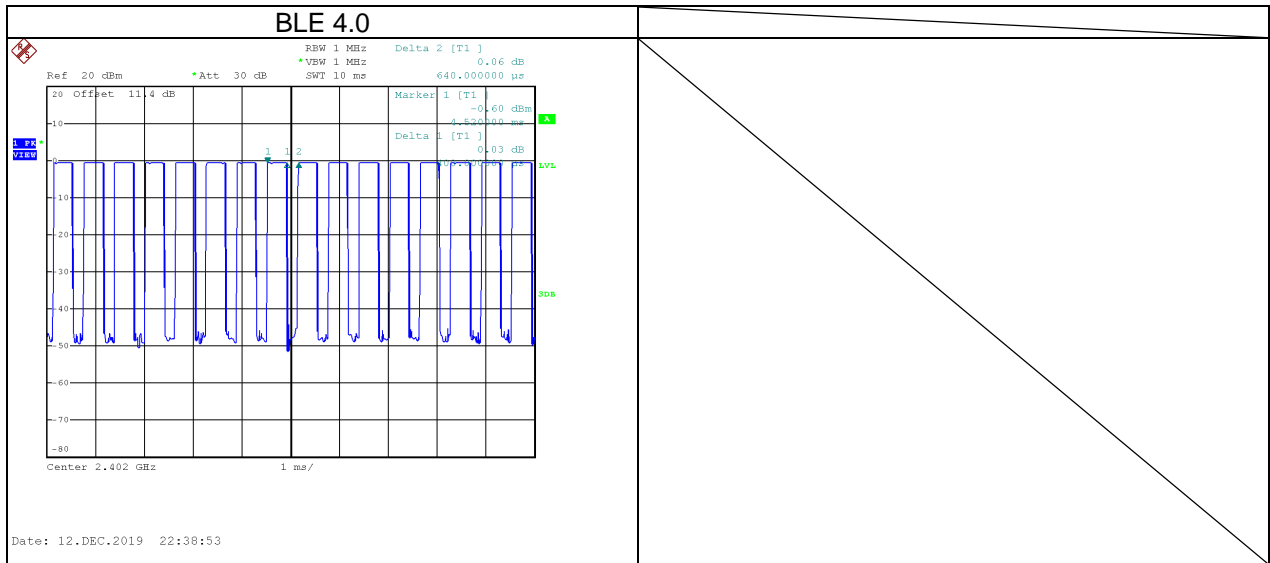

Remark	Delta 1	Delta 2	On Time/Period	10 log(1/Duty Cycle)		
Mode	ON (ms)	Numbers (ON)	On Time (B) (ms)	Period (ON+OFF) (ms)	Duty Cycle (%)	Duty Factor (dB)
BLE 4.0	0.400	1	0.400	0.640	62.50%	2.04



## 2 GENERAL INFORMATION

### 2.1 DESCRIPTION OF EUT

Equipment	7 inch Touch Screen wall mount
Model Name	M201923002, TSW-770-B-S, TSW-770-W-S, TSW-770P-B-S, TSW-770P-W-S, TSS-770-B-S, TSS-770-W-S
Brand Name	CRESTRON
Model Difference	M201923002 includes six series: TSW-770-B-S, TSW-770-W-S, TSW-770P-B-S, TSW-770P-W-S, TSS-770-B-S, TSS-770-W-S All modes are identical to each other except below: B: Black, W: White, P: Portrait, S: Smooth, TSS: Touch Screen Scheduling
Power Source	DC voltage supplied from POE.
Power Rating	I/P: 48 VDC 350mA (802.3at type 1), 48 VDC 600mA (802.3at type 2)
Products Covered	N/A
Frequency Range	2400 MHz ~ 2483.5 MHz
Operation Frequency	2402 MHz ~ 2480 MHz
Modulation Technology	GFSK
Transfer Rate	1Mbps
Output Power Max.	1.63 dBm (0.0015 W)
Test Model	M201923002
Sample Status	Engineering Sample
EUT Modification(s)	N/A

**NOTE:**

- (1) For a more detailed features description, please refer to the manufacturer's specifications or the user's manual.
- (2) Channel List:

Channel	Frequency (MHz)	Channel	Frequency (MHz)
00	2402	20	2442
01	2404	21	2444
02	2406	22	2446
03	2408	23	2448
04	2410	24	2450
05	2412	25	2452
06	2414	26	2454
07	2416	27	2456
08	2418	28	2458
09	2420	29	2460
10	2422	30	2462
11	2424	31	2464
12	2426	32	2466
13	2428	33	2468
14	2430	34	2470
15	2432	35	2472
16	2434	36	2474
17	2436	37	2476
18	2438	38	2478
19	2440	39	2480

- (3) Table for Filed Antenna:

Ant.	Brand	Test Model	Antenna Type	Connector	Gain (dBi)
1	YAGEO	TSW WLAN MAIN	PIFA	IPEX	-3.92

**2.2 TEST MODES**

Test Items	Test mode	Channel	Note
Transmitter Radiated Emissions (below 1GHz)	1 Mbps	00	-
Transmitter Radiated Emissions (above 1GHz)	1 Mbps	00/39	Bandedge
	1 Mbps	00/19/39	Harmonic
Bandwidth	1 Mbps	00/19/39	-
Output Power	1 Mbps	00/19/39	-
Power Spectral Density	1 Mbps	00/19/39	-
Antenna conducted Spurious Emission	1 Mbps	00/19/39	-

**NOTE:**

- (1) The Radiated emissions test was verified based on the worst conducted power and Bandwidth test results reported in the original report.
- (2) For radiated emission band edge test, both Vertical and Horizontal are evaluated, but only the worst case (Horizontal) is recorded.
- (3) All X, Y and Z axes are evaluated, but only the worst case (X axis) is recorded.

### 2.3 BLOCK DIAGRAM SHOWING THE CONFIGURATION OF SYSTEM TESTED

Equipment letters and Cable numbers refer to item numbers described in the tables of clause 2.4.

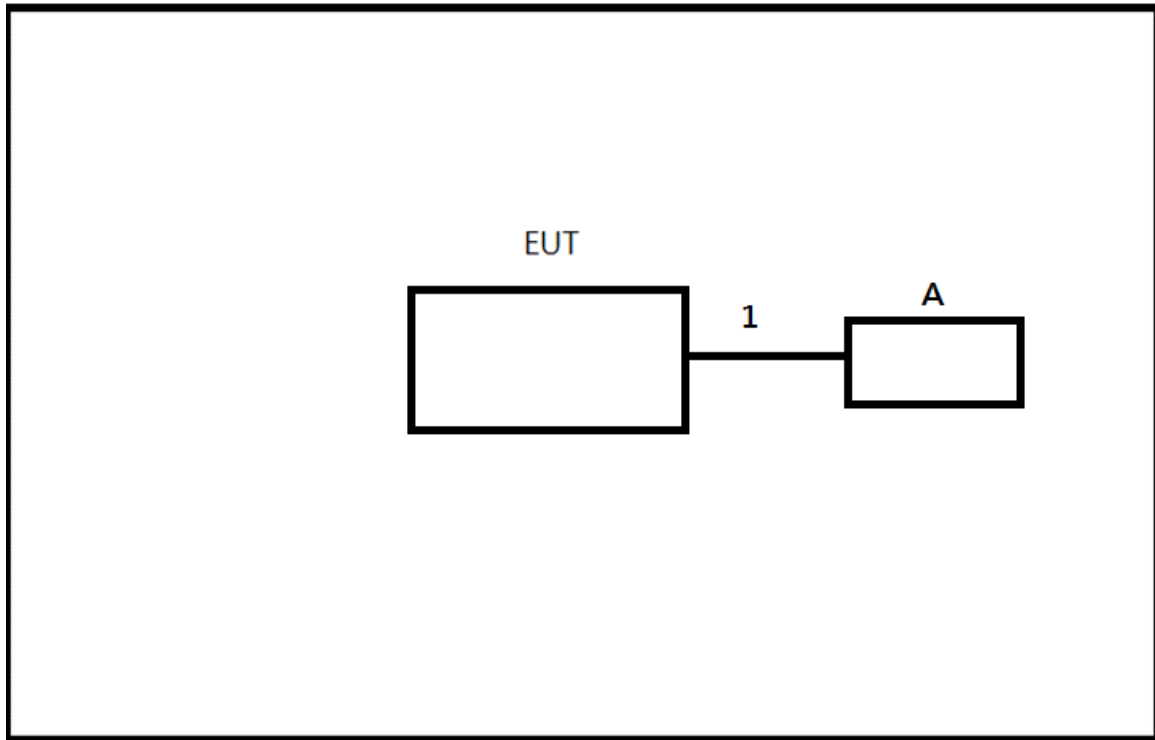

### 2.4 SUPPORT UNITS

Item	Equipment	Brand	Model No.	Series No.	Remarks
A	MANAGED POE SWITCH	CRESTRON	CEN-SWPOE-16	N/A	-

Item	Shielded	Ferrite Core	Length	Cable Type	Remarks
1	NO	NO	3m	LAN Cable	-

### 3 RADIATED EMISSIONS TEST

#### 3.1 LIMIT

In case the emission fall within the restricted band specified on 15.205, then the 15.209 limit in the table below has to be followed.

#### LIMITS OF RADIATED EMISSIONS MEASUREMENT (9 kHz to 1000 MHz)

Frequency (MHz)	Field Strength (microvolts/meter)	Measurement Distance (meters)
0.009~0.490	2400/F(KHz)	300
0.490~1.705	24000/F(KHz)	30
1.705~30.0	30	30
30~88	100	3
88~216	150	3
216~960	200	3
960~1000	500	3

#### LIMITS OF RADIATED EMISSIONS MEASUREMENT (Above 1000 MHz)

Frequency (MHz)	Radiated Emissions (dBuV/m)		Measurement Distance (meters)
	Peak	Average	
Above 1000	74	54	3

#### NOTE:

- (1) The limit for radiated test was performed according to FCC Part 15, Subpart C.
- (2) The tighter limit applies at the band edges.
- (3) Emission level (dBuV/m)=20log Emission level (uV/m).
- (4) The test result calculated as following:

Measurement Value = Reading Level + Correct Factor

Correct Factor = Antenna Factor + Cable Loss - Amplifier Gain(if use)

Margin Level = Measurement Value - Limit Value

Calculation example:

Reading Level		Correct Factor		Measurement Value
19.11	+	2.11	=	21.22

Measurement Value		Limit Value		Margin Level
21.22	-	54	=	-32.78

Spectrum Parameter	Setting
Attenuation	Auto
Start Frequency	1000 MHz
Stop Frequency	10th carrier harmonic
RBW / VBW (Emission in restricted band)	1MHz / 3MHz for Peak, 1MHz / 1/T for Average

Spectrum Parameter	Setting
Attenuation	Auto
Start ~ Stop Frequency	9KHz~90KHz for PK/AVG detector
Start ~ Stop Frequency	90KHz~110KHz for QP detector
Start ~ Stop Frequency	110KHz~490KHz for PK/AVG detector
Start ~ Stop Frequency	490KHz~30MHz for QP detector
Start ~ Stop Frequency	30MHz~1000MHz for QP detector

### 3.2 TEST PROCEDURE

- a. The measuring distance of 3 m shall be used for measurements. The EUT was placed on the top of a rotating table 0.8 meter above the ground at a 3 meter semi-anechoic chamber. The table was rotated 360 degrees to determine the position of the highest radiation.(below 1GHz)
- b. The measuring distance of 3 m shall be used for measurements. The EUT was placed on the top of a rotating table 1.5 meter above the ground at a 3 meter semi-anechoic chamber. The table was rotated 360 degrees to determine the position of the highest radiation.(above 1GHz)
- c. The height of the equipment or of the substitution antenna shall be 0.8 m or 1.5 m, the height of the test antenna shall vary between 1 m to 4 m. Both horizontal and vertical polarizations of the antenna are set to make the measurement.
- d. For each suspected emission, the EUT was arranged to its worst case and then the antenna was tuned to heights find the maximum reading (used Bore sight function).
- e. The receiver system was set to peak and average detect function and specified bandwidth with maximum hold mode when the test frequency is above 1GHz.
- f. The initial step in collecting radiated emission data is a receiver peak detector mode pre-scanning the measurement frequency range. Significant peaks are then marked and then Quasi Peak detector mode re-measured.
- g. All readings are Peak unless otherwise stated QP in column of Note. Peak denotes that the Peak reading compliance with the QP Limits and then QP Mode measurement didn't perform. (below 1GHz)
- h. All readings are Peak Mode value unless otherwise stated AVG in column of Note. If the Peak Mode Measured value compliance with the Peak Limits and lower than AVG Limits, the EUT shall be deemed to meet both Peak & AVG Limits and then only Peak Mode was measured, but AVG Mode didn't perform. (above 1GHz)
- i. For the actual test configuration, please refer to the related Item – EUT TEST PHOTO.

### 3.3 DEVIATION FROM TEST STANDARD

No deviation.

### 3.4 TEST SETUP

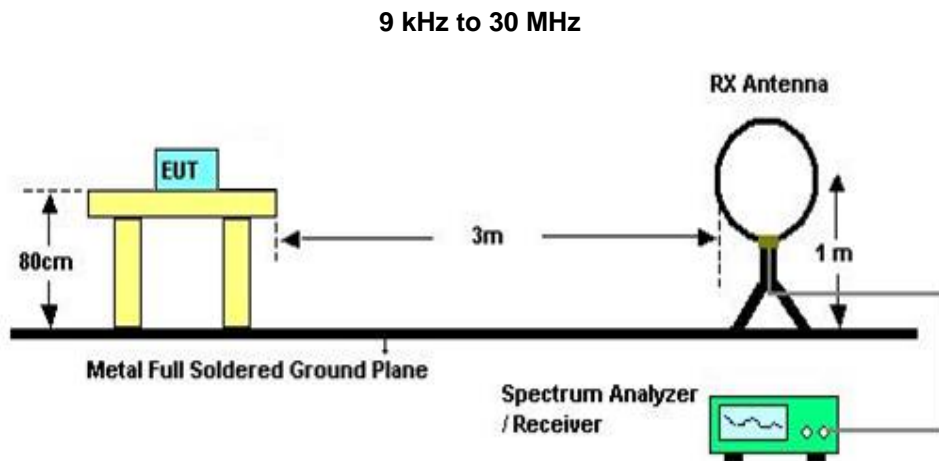

### 30 MHz to 1 GHz

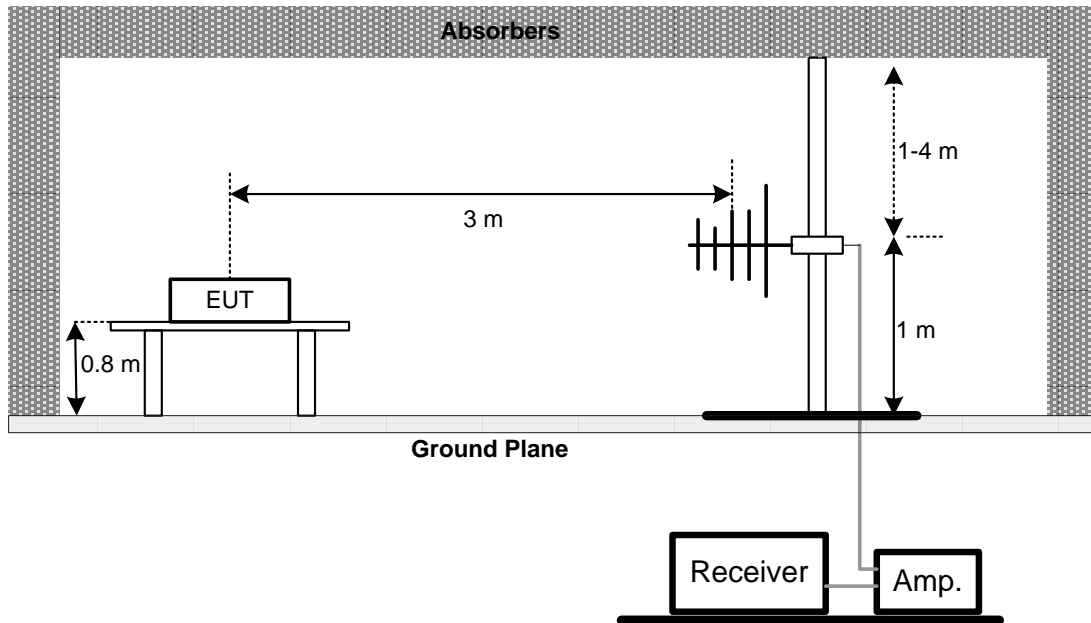

### Above 1 GHz

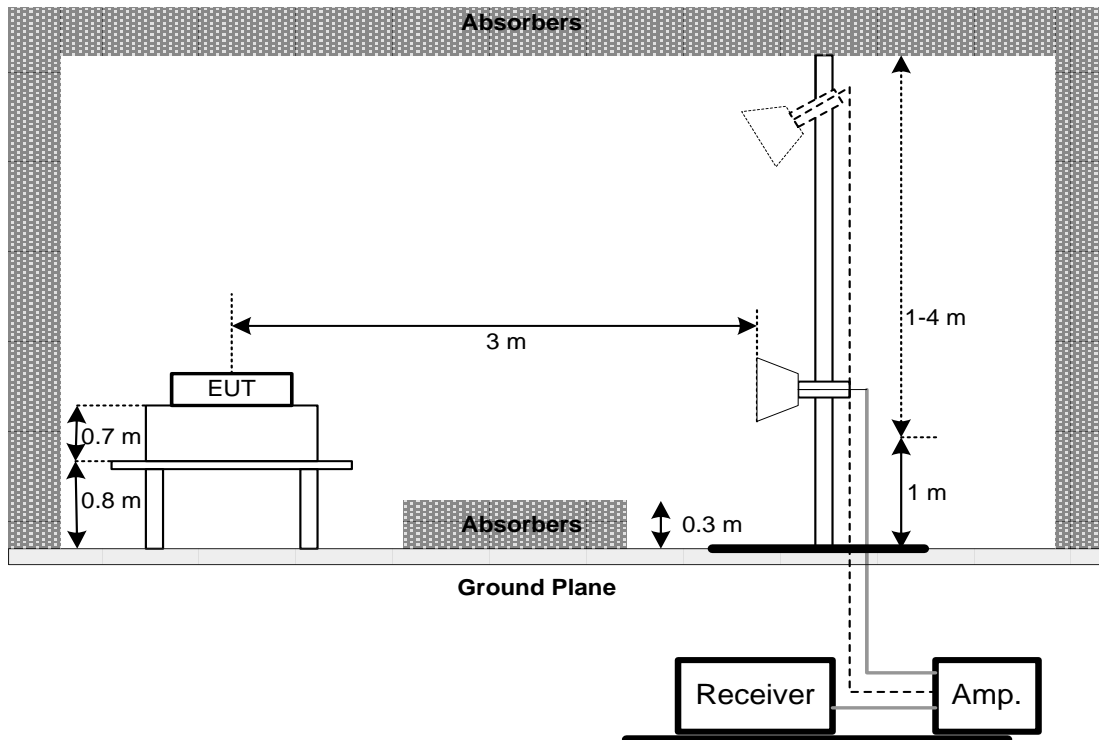

### 3.5 EUT OPERATING CONDITIONS

The EUT was programmed to be in continuously transmitting mode.

**3.6 TEST RESULT – 9 KHZ TO 30 MHZ**

Please refer to the APPENDIX A.

**3.7 TEST RESULT – 30 MHZ TO 1 GHZ**

Please refer to the APPENDIX B.

**3.8 TEST RESULT – ABOVE 1 GHZ**

Please refer to the APPENDIX C.

**NOTE:**

- (1) No limit: This is fundamental signal, the judgment is not applicable.  
For fundamental signal judgment was referred to Peak output test.

**4 BANDWIDTH TEST****4.1 APPLIED PROCEDURES / LIMIT**

FCC Part15 (15.247) , Subpart C				
Section	Test Item	Limit	Frequency Range (MHz)	Result
15.247(a)(2)	Bandwidth	$\geq 500\text{KHz}$ (6dB bandwidth)	2400-2483.5	PASS

**4.2 TEST PROCEDURE**

- a. The EUT was directly connected to the spectrum analyzer and antenna output port as show in the block diagram below,
- b. Spectrum Setting : RBW= 100KHz, VBW=300KHz, Sweep time = 2.5 ms.

**4.3 DEVIATION FROM STANDARD**

No deviation.

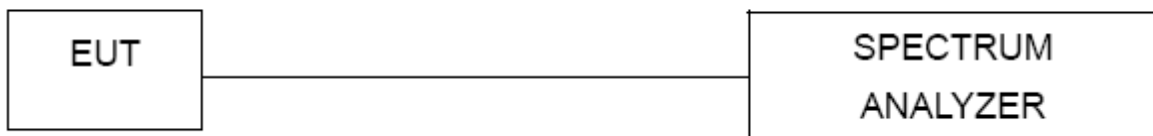
**4.4 TEST SETUP****4.5 EUT OPERATION CONDITIONS**

The EUT tested system was configured as the statements of 4.1.5 unless otherwise a special operating condition is specified in the follows during the testing.

**4.6 TEST RESULTS**

Please refer to the APPENDIX D.



**5 OUTPUT POWER TEST****5.1 APPLIED PROCEDURES / LIMIT**

FCC Part15 (15.247) , Subpart C				
Section	Test Item	Limit	Frequency Range (MHz)	Result
15.247(b)(3)	Maximum Output Power	1 watt or 30dBm	2400-2483.5	PASS

**5.2 TEST PROCEDURE**

- a. The EUT was directly connected to the power meter and antenna output port as show in the block diagram below,
- b. The maximum peak conducted output power was performed in accordance with method 9.1.2 of FCC KDB 558074 D01 DTS Meas Guidance.

**5.3 DEVIATION FROM STANDARD**

No deviation.

**5.4 TEST SETUP****5.5 EUT OPERATION CONDITIONS**

The EUT tested system was configured as the statements of 4.1.5 unless otherwise a special operating condition is specified in the follows during the testing.

**5.6 TEST RESULTS**

Please refer to the APPENDIX E.

**6 POWER SPECTRAL DENSITY TEST****6.1 APPLIED PROCEDURES / LIMIT**

FCC Part15 (15.247) , Subpart C				
Section	Test Item	Limit	Frequency Range (MHz)	Result
15.247(e)	Power Spectral Density	8 dBm (in any 3KHz)	2400-2483.5	PASS

**6.2 TEST PROCEDURE**

- a. The EUT was directly connected to the spectrum analyzer and antenna output port as show in the block diagram below,
- b. Spectrum Setting: RBW=3KHz, VBW=10 KHz, Sweep time = auto.

**6.3 DEVIATION FROM STANDARD**

No deviation.

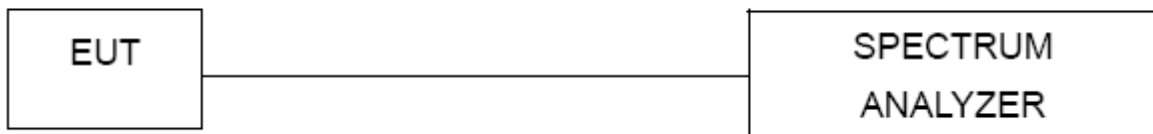
**6.4 TEST SETUP****6.5 EUT OPERATION CONDITIONS**

The EUT tested system was configured as the statements of 4.1.5 unless otherwise a special operating condition is specified in the follows during the testing.

**6.6 TEST RESULTS**

Please refer to the APPENDIX F.

## 7 ANTENNA CONDUCTED SPURIOUS EMISSION

### 7.1 APPLIED PROCEDURES / LIMIT

In any 100 kHz bandwidth outside the frequency band in which the spread spectrum or digitally modulated device is operating, the RF power that is produced shall be at least 20 dB below that in the 100 kHz bandwidth within the band that contains the highest level of the desired power, based on either an RF conducted or a radiated measurement, provided that the transmitter demonstrates compliance with the peak conducted power limits.

### 7.2 TEST PROCEDURE

- a. The EUT was directly connected to the spectrum analyzer and antenna output port as show in the block diagram below,
- b. Spectrum Setting : RBW= 100KHz, VBW=300KHz, Sweep time = 10 ms.
- c. Offset=antenna gain+cable loss

### 7.3 DEVIATION FROM STANDARD

No deviation.

### 7.4 TEST SETUP

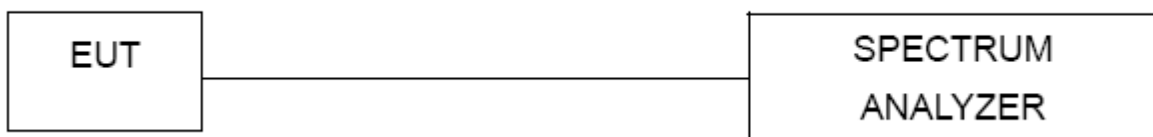

### 7.5 EUT OPERATION CONDITIONS

The EUT tested system was configured as the statements of 4.1.5 unless otherwise a special operating condition is specified in the follows during the testing.

### 7.6 TEST RESULTS

Please refer to the APPENDIX G.

## 8 LIST OF MEASURING EQUIPMENTS

Radiated Emissions						
Item	Kind of Equipment	Manufacturer	Type No.	Serial No.	Calibrated Date	Calibrated Until
1	Preamplifier	EMCI	EMC001340	980555	2019/4/12	2020/4/11
2	Preamplifier	EMCI	EMC02325B	980217	2019/4/12	2020/4/11
3	Preamplifier	EMCI	EMC012645B	980267	2019/4/12	2020/4/11
4	Test Cable	EMCI	EMC104-SM-SM-800	150207	2019/4/12	2020/4/11
5	Test Cable	EMCI	EMC104-SM-SM-3000	151205	2019/4/12	2020/4/11
6	Test Cable	EMCI	EMC-SM-SM-7000	180408	2019/4/12	2020/4/11
7	MXE EMI Receiver	Agilent	N9038A	MY55420127	2019/3/26	2020/3/25
8	Signal Analyzer	Agilent	N9010A	MY56480554	2019/6/6	2020/6/5
9	Loop Ant	EMCO	EMCI-LPA600	274	2019/5/31	2020/5/30
10	Horn Ant	SCHWARZBECK	BBHA 9120D	9120D-1342	2019/6/10	2020/6/9
11	Trilog-Broadband Antenna	Schwarzbeck	VULB 9168	000992	2019/5/29	2020/5/28
12	5dB Attenuator	EMCI	EMCI-N-6-05	AT-N0508	2019/5/29	2020/5/28

Bandwidth						
Item	Kind of Equipment	Manufacturer	Type No.	Serial No.	Calibrated Date	Calibrated Until
1	Spectrum Analyzer	R&S	FSP40	100129	2019/5/23	2020/5/22

Output Power						
Item	Kind of Equipment	Manufacturer	Type No.	Serial No.	Calibrated Date	Calibrated Until
1	Power Meter	Anritsu	ML2487A	6K00004714	2019/6/20	2020/6/18
2	Power Sensor	Anritsu	MA2491A	1725282	2019/6/20	2020/6/18

Power Spectral Density						
Item	Kind of Equipment	Manufacturer	Type No.	Serial No.	Calibrated Date	Calibrated Until
1	Spectrum Analyzer	R&S	FSP40	100129	2019/5/23	2020/5/22

Antenna conducted Spurious Emission						
Item	Kind of Equipment	Manufacturer	Type No.	Serial No.	Calibrated Date	Calibrated Until
1	Spectrum Analyzer	R&S	FSP40	100129	2019/5/23	2020/5/22

Remark: "N/A" denotes no model name, no serial no. or no calibration specified.  
All calibration period of equipment list is one year.

**9 EUT TEST PHOTO**

Please refer to document Appendix No.: TP-1911T045-FCCP-1 (APPENDIX-TEST PHOTOS).

**10 EUT PHOTOS**

Please refer to document Appendix No.: EP-1911T045-1 (APPENDIX-EUT PHOTOS).

## **APPENDIX A    RADIATED EMISSIONS - 9 KHZ TO 30 MHZ**

Test Mode	TX Mode 2402MHz _CH00_1Mbps	Tested Date	2019/12/9
Test Voltage	DC 48V	Azimuth Angle	90°

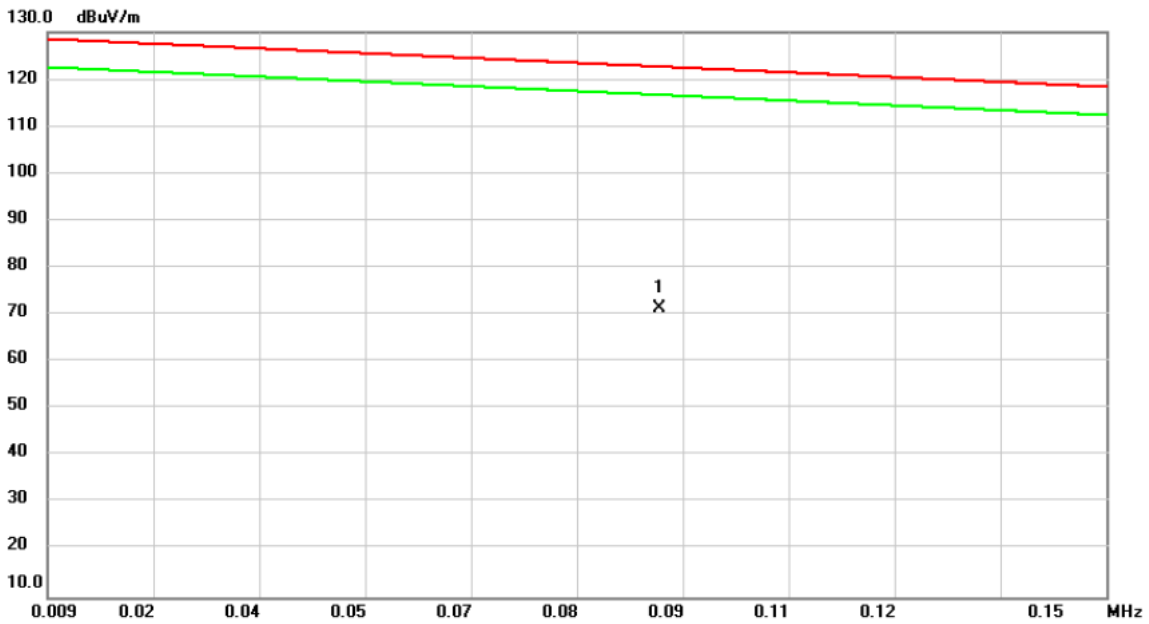

No.	Mk.	Freq.	Reading Level	Correct Factor	Measurement	Limit	Margin	Detector	Comment
		MHz	dBuV	dB	dBuV/m	dBuV/m	dB		
1	*	0.0905	54.21	17.26	71.47	122.63	-51.16	AVG	

**REMARKS:**

- (1) Measurement Value = Reading Level + Correct Factor.
- (2) Margin Level = Measurement Value - Limit Value.

Test Mode	TX Mode 2402MHz _CH00_1Mbps	Tested Date	2019/12/9
Test Voltage	DC 48V	Azimuth Angle	90°

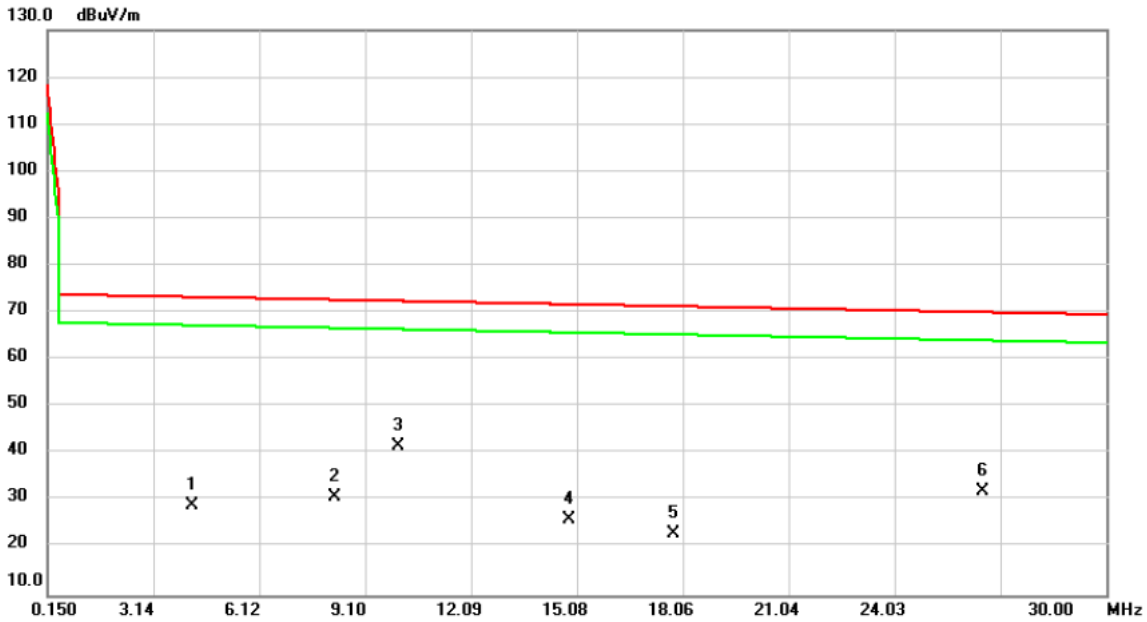

No.	Mk.	Freq. MHz	Reading Level dBuV	Correct Factor dB	Measure- ment dBuV/m	Limit dBuV/m	Margin dB	Detector	Comment
1		4.2394	32.87	-3.82	29.05	73.26	-44.21	QP	
2		8.2393	35.36	-4.41	30.95	72.68	-41.73	QP	
3	*	10.0304	46.48	-4.71	41.77	72.42	-30.65	QP	
4		14.8660	31.07	-4.99	26.08	71.72	-45.64	QP	
5		17.7914	29.17	-6.15	23.02	71.30	-48.28	QP	
6		26.5075	40.65	-8.55	32.10	70.04	-37.94	QP	

**REMARKS:**

- (1) Measurement Value = Reading Level + Correct Factor.
- (2) Margin Level = Measurement Value - Limit Value.



Test Mode	TX Mode 2402MHz _CH00_1Mbps	Tested Date	2019/12/9
Test Voltage	DC 48V	Azimuth Angle	0°

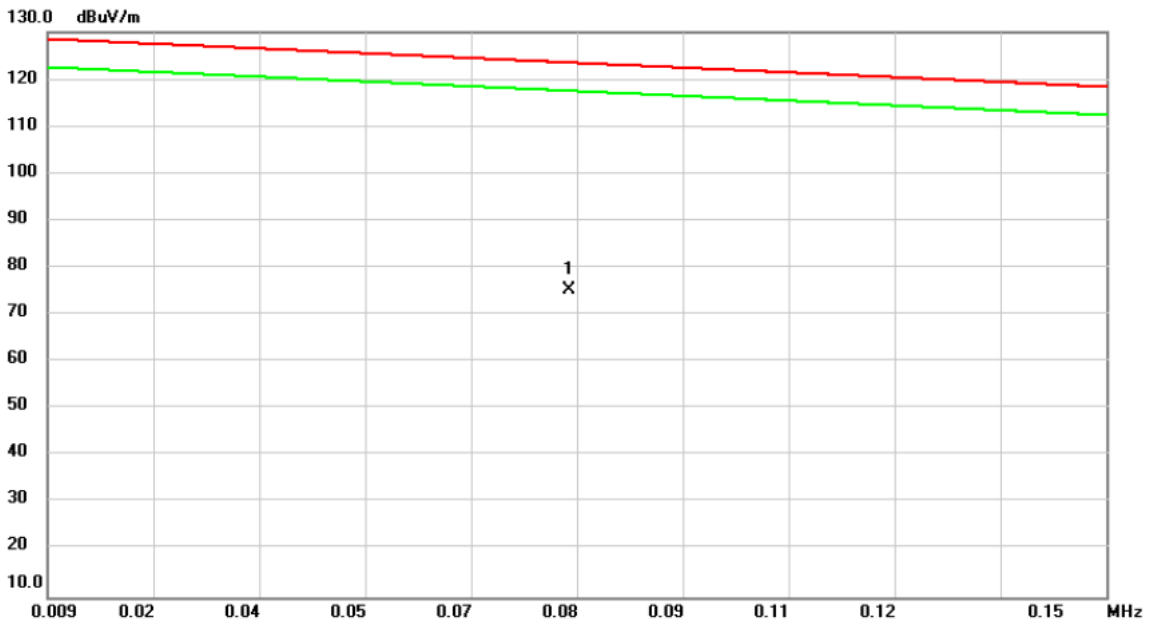

No.	Mk.	Freq.	Reading Level	Correct Factor	Measurement	Limit	Margin	Detector	Comment
		MHz	dBuV	dB	dBuV/m	dBuV/m	dB		
1	*	0.0784	56.99	18.38	75.37	123.50	-48.13	AVG	

REMARKS:

- (1) Measurement Value = Reading Level + Correct Factor.
- (2) Margin Level = Measurement Value - Limit Value.

Test Mode	TX Mode 2402MHz _CH00_1Mbps	Tested Date	2019/12/9
Test Voltage	DC 48V	Azimuth Angle	0°

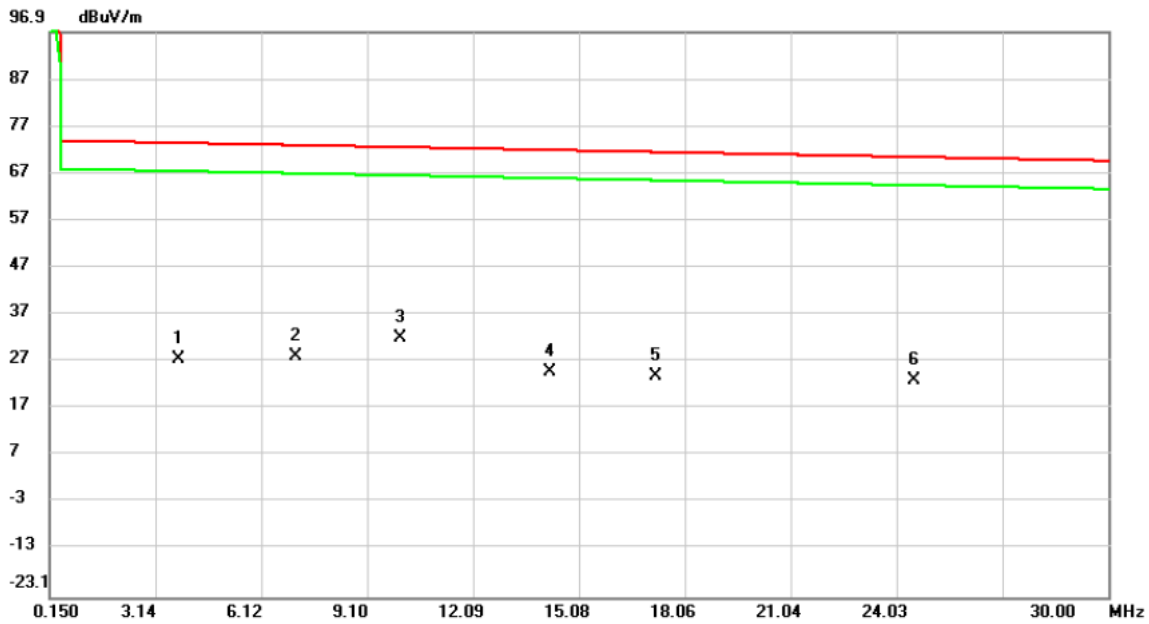

No. Mk.	Freq. MHz	Reading Level dBuV	Correct Factor dB	Measurement dBuV/m	Limit dBuV/m	Margin dB	Detector	Comment
1	3.7917	31.23	-3.77	27.46	73.32	-45.86	QP	
2	7.0752	32.20	-4.14	28.06	72.85	-44.79	QP	
3 *	10.0304	36.54	-4.71	31.83	72.42	-40.59	QP	
4	14.2691	29.75	-4.87	24.88	71.81	-46.93	QP	
5	17.2540	29.90	-5.93	23.97	71.38	-47.41	QP	
6	24.5076	31.39	-8.40	22.99	70.33	-47.34	QP	

**REMARKS:**

- (1) Measurement Value = Reading Level + Correct Factor.
- (2) Margin Level = Measurement Value - Limit Value.

## **APPENDIX B    RADIATED EMISSIONS - 30 MHZ TO 1 GHZ**

Test Mode	TX Mode 2402MHz _CH00_1Mbps	Tested Date	2019/12/9
Test Voltage	DC 48V	Polarization	Vertical

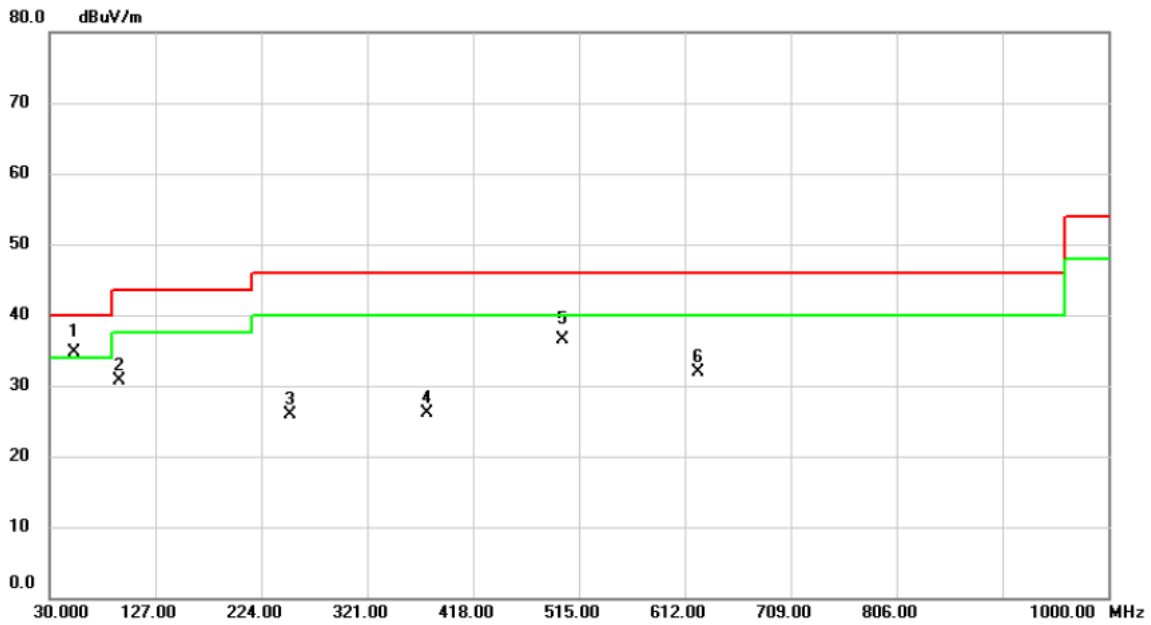

No.	Mk.	Freq. MHz	Reading Level dBuV	Correct Factor dB	Measure- ment dBuV/m	Limit dBuV/m	Margin dB	Detector	Comment
1	*	52.3100	46.58	-11.86	34.72	40.00	-5.28	QP	
2		94.0200	47.71	-17.04	30.67	43.50	-12.83	peak	
3		250.1900	38.82	-12.92	25.90	46.00	-20.10	peak	
4		375.3200	35.08	-9.05	26.03	46.00	-19.97	peak	
5		500.4500	42.53	-6.12	36.41	46.00	-9.59	QP	
6		624.6100	35.51	-3.54	31.97	46.00	-14.03	peak	

**REMARKS:**

- (1) Measurement Value = Reading Level + Correct Factor.
- (2) Margin Level = Measurement Value - Limit Value.

Test Mode	TX Mode 2402MHz _CH00_1Mbps	Tested Date	2019/12/9
Test Voltage	DC 48V	Polarization	Horizontal

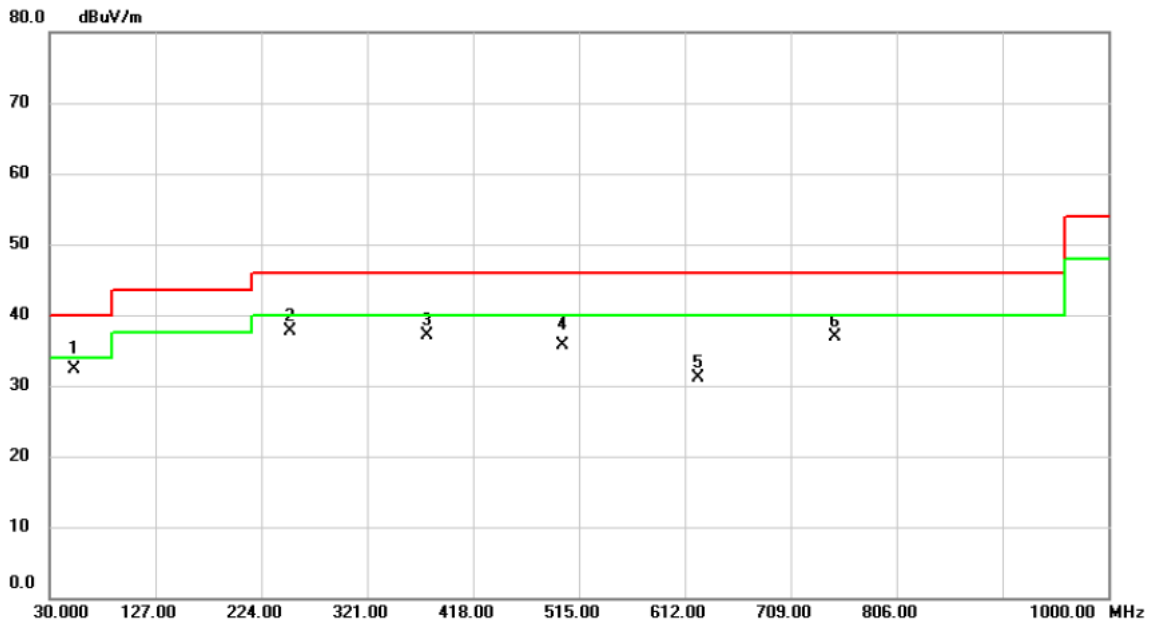

No.	Mk.	Freq. MHz	Reading Level dBuV	Correct Factor dB	Measure- ment dBuV/m	Limit dBuV/m	Margin dB	Detector	Comment
1	*	52.3100	44.22	-11.86	32.36	40.00	-7.64	QP	
2		250.1900	50.61	-12.92	37.69	46.00	-8.31	peak	
3		375.3200	46.18	-9.05	37.13	46.00	-8.87	peak	
4		500.4500	41.76	-6.12	35.64	46.00	-10.36	QP	
5		624.6100	34.56	-3.54	31.02	46.00	-14.98	peak	
6		749.7400	38.20	-1.36	36.84	46.00	-9.16	peak	

**REMARKS:**

- (1) Measurement Value = Reading Level + Correct Factor.
- (2) Margin Level = Measurement Value - Limit Value.

## **APPENDIX C    RADIATED EMISSIONS - ABOVE 1 GHZ**

Test Mode	TX Mode 2402MHz _CH00_1Mbps	Tested Date	2019/12/9
Test Voltage	DC 48V	Polarization	Horizontal

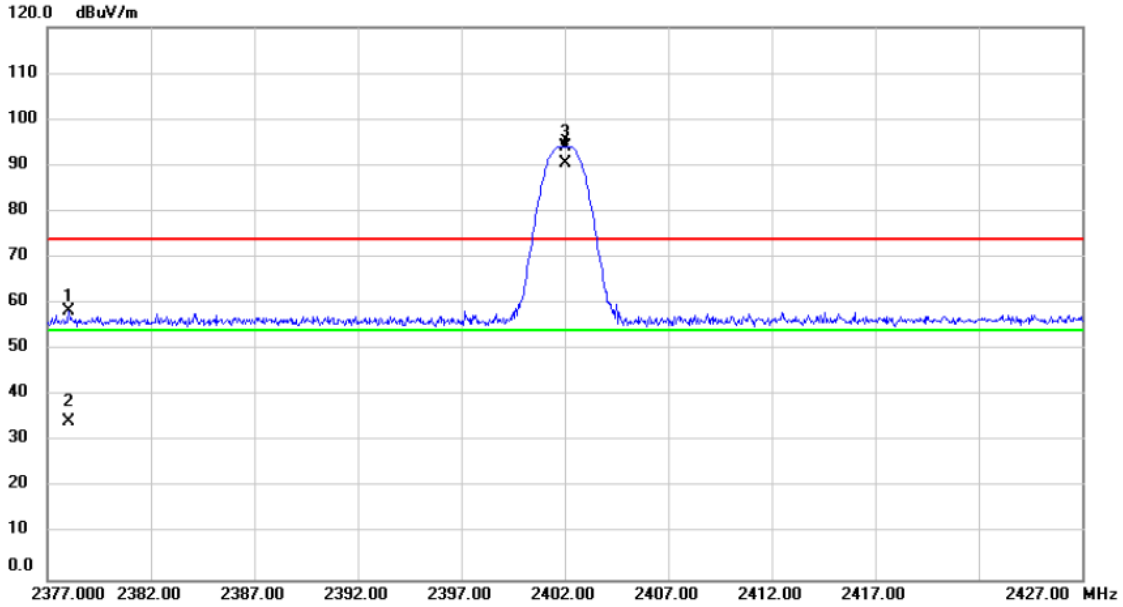

No.	Mk.	Freq. MHz	Reading Level dBuV	Correct Factor dB	Measure- ment dBuV/m	Limit dBuV/m	Margin dB	Detector	Comment
1		2378.000	27.15	31.19	58.34	74.00	-15.66	peak	
2		2378.000	3.05	31.19	34.24	54.00	-19.76	AVG	
3	X	2402.000	62.81	31.30	94.11	74.00	20.11	peak	
4	*	2402.000	59.19	31.30	90.49	54.00	36.49	AVG	

**REMARKS:**

- (1) Measurement Value = Reading Level + Correct Factor.
- (2) Margin Level = Measurement Value - Limit Value.

Test Mode	TX Mode 2480MHz _CH39_1Mbps	Tested Date	2019/12/9
Test Voltage	DC 48V	Polarization	Horizontal

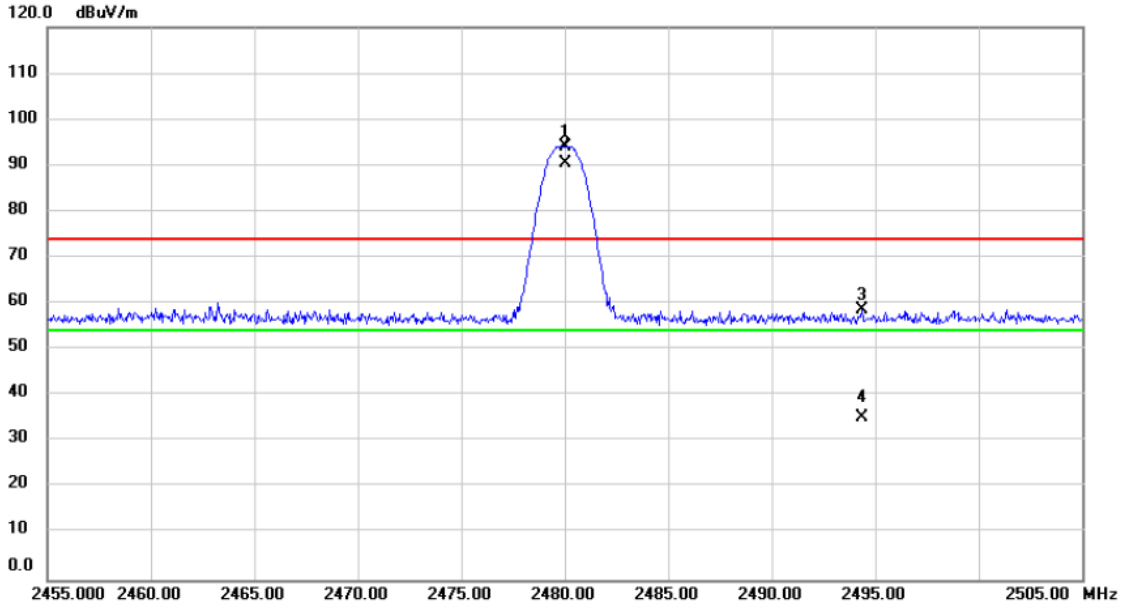

No.	Mk.	Freq.	Reading Level	Correct Factor	Measurement	Limit	Margin	Detector	Comment
		MHz	dBuV	dB	dBuV/m	dBuV/m	dB		
1	X	2480.000	62.43	31.65	94.08	74.00	20.08	peak	
2	*	2480.000	58.88	31.65	90.53	54.00	36.53	AVG	
3		2494.350	26.94	31.70	58.64	74.00	-15.36	peak	
4		2494.350	3.52	31.70	35.22	54.00	-18.78	AVG	

**REMARKS:**

- (1) Measurement Value = Reading Level + Correct Factor.
- (2) Margin Level = Measurement Value - Limit Value.



Test Mode	TX Mode 2402MHz _CH00_1Mbps	Tested Date	2019/12/9
Test Voltage	DC 48V	Polarization	Vertical

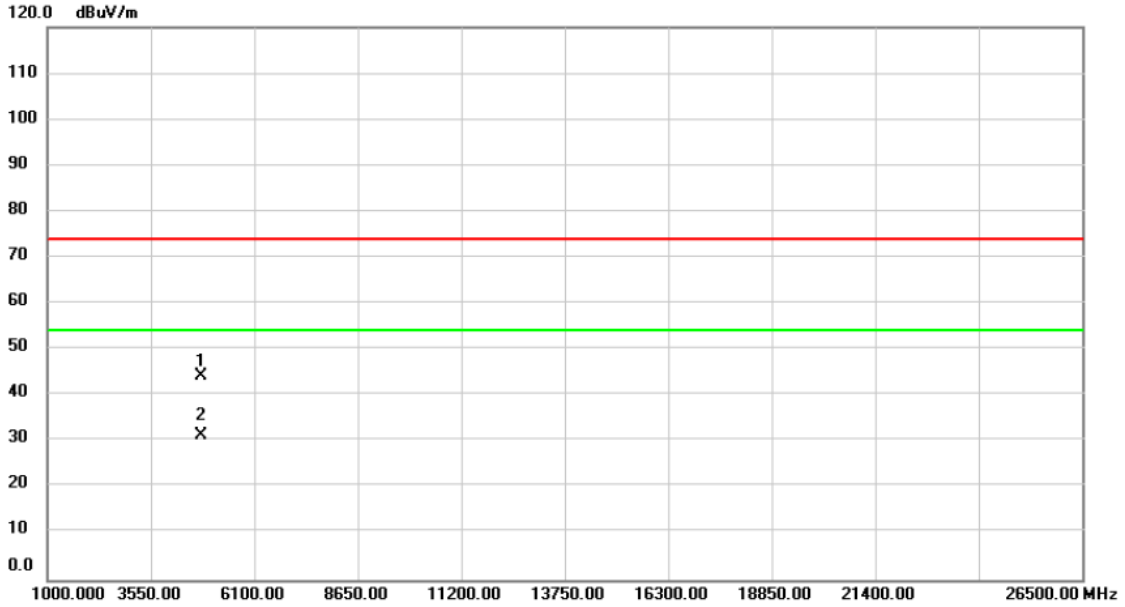

No. Mk.	Freq. MHz	Reading Level dBuV	Correct Factor dB	Measurement dBuV/m	Limit dBuV/m	Margin dB	Detector	Comment
1	4804.000	54.86	-10.58	44.28	74.00	-29.72	peak	
2 *	4804.000	41.90	-10.58	31.32	54.00	-22.68	AVG	

**REMARKS:**

- (1) Measurement Value = Reading Level + Correct Factor.
- (2) Margin Level = Measurement Value - Limit Value.

Test Mode	TX Mode 2402MHz _CH00_1Mbps	Tested Date	2019/12/9
Test Voltage	DC 48V	Polarization	Horizontal

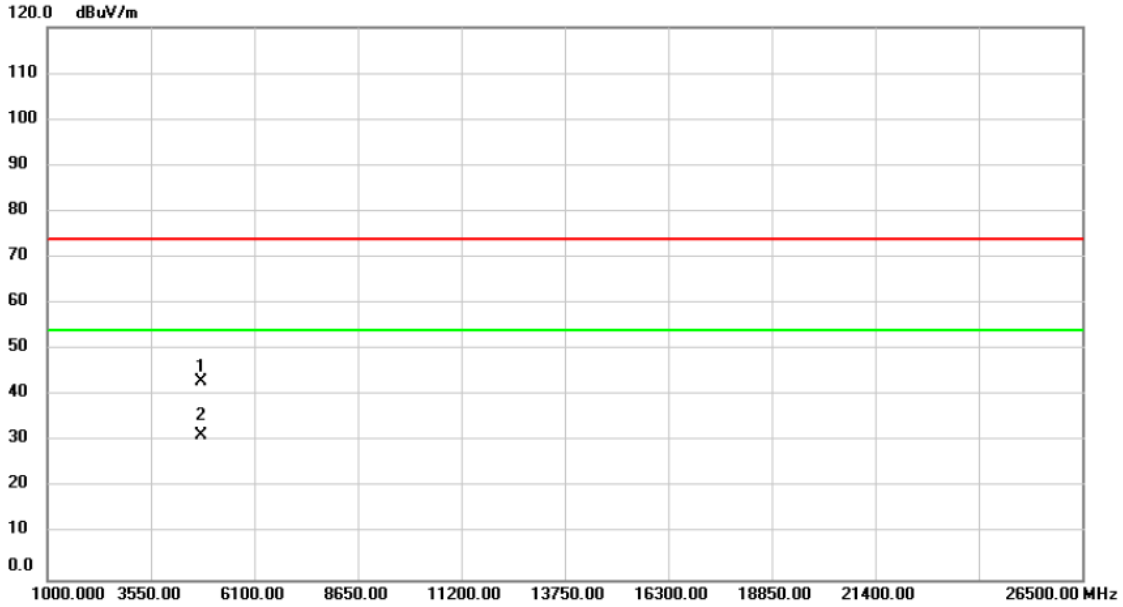

No. Mk.	Freq. MHz	Reading Level dBuV	Correct Factor dB	Measure- ment dBuV/m	Limit dBuV/m	Margin dB	Detector	Comment
1	4804.000	53.73	-10.58	43.15	74.00	-30.85	peak	
2 *	4804.000	41.87	-10.58	31.29	54.00	-22.71	AVG	

**REMARKS:**

- (1) Measurement Value = Reading Level + Correct Factor.
- (2) Margin Level = Measurement Value - Limit Value.

Test Mode	TX Mode 2440MHz _CH19_1Mbps	Tested Date	2019/12/9
Test Voltage	DC 48V	Polarization	Vertical

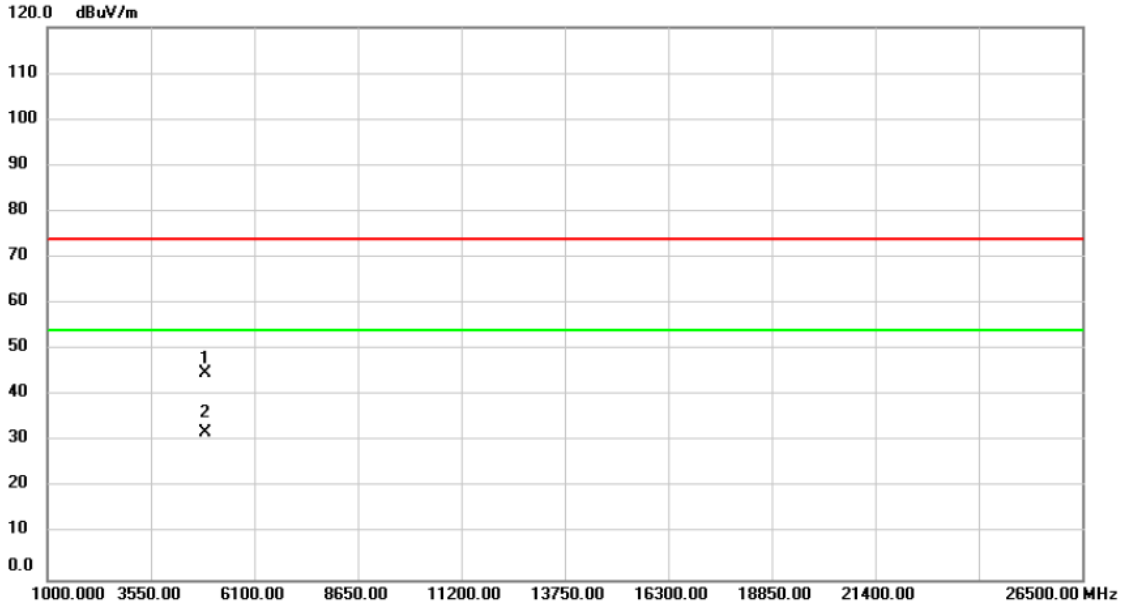

No. Mk.	Freq. MHz	Reading Level dBuV	Correct Factor dB	Measure- ment dBuV/m	Limit dBuV/m	Margin dB	Detector	Comment
1	4880.000	55.19	-10.39	44.80	74.00	-29.20	peak	
2 *	4880.000	42.25	-10.39	31.86	54.00	-22.14	AVG	

**REMARKS:**

- (1) Measurement Value = Reading Level + Correct Factor.
- (2) Margin Level = Measurement Value - Limit Value.

Test Mode	TX Mode 2440MHz _CH19_1Mbps	Tested Date	2019/12/9
Test Voltage	DC 48V	Polarization	Horizontal

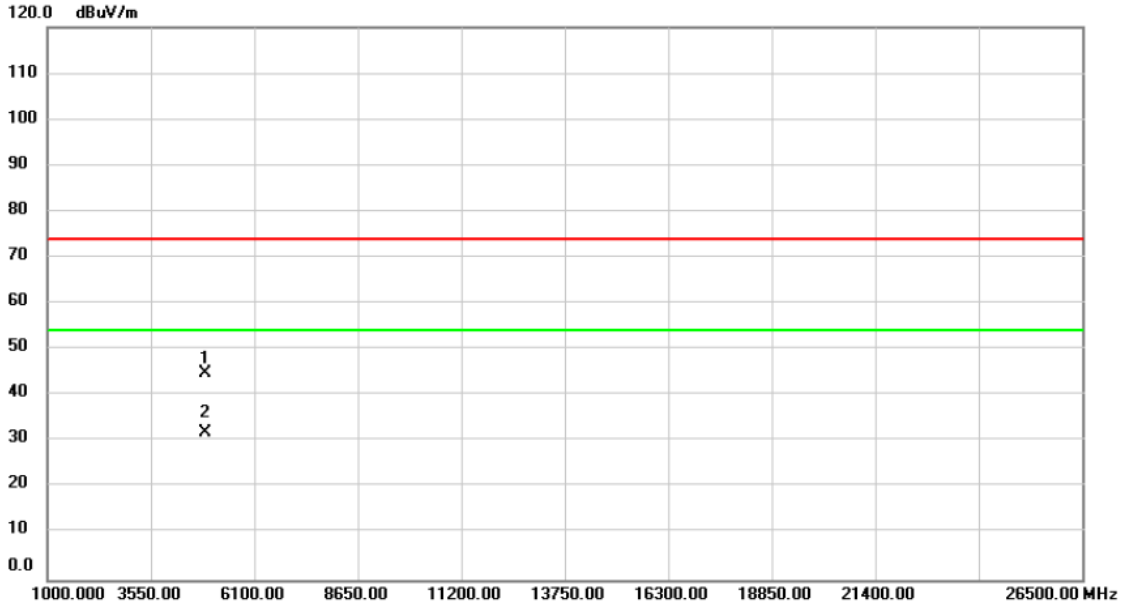

No. Mk.	Freq. MHz	Reading Level dBuV	Correct Factor dB	Measure- ment dBuV/m	Limit dBuV/m	Margin dB	Detector	Comment
1	4880.000	55.27	-10.39	44.88	74.00	-29.12	peak	
2 *	4880.000	42.33	-10.39	31.94	54.00	-22.06	AVG	

**REMARKS:**

- (1) Measurement Value = Reading Level + Correct Factor.
- (2) Margin Level = Measurement Value - Limit Value.

Test Mode	TX Mode 2480MHz _CH39_1Mbps	Tested Date	2019/12/9
Test Voltage	DC 48V	Polarization	Vertical

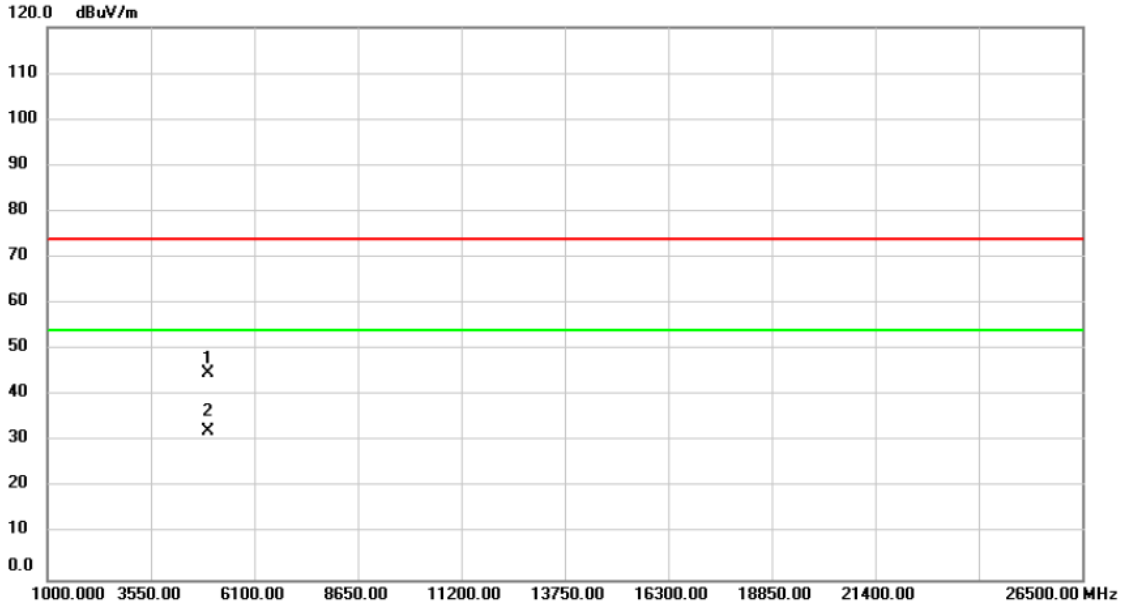

No. Mk.	Freq. MHz	Reading Level dBuV	Correct Factor dB	Measure- ment dBuV/m	Limit dBuV/m	Margin dB	Detector	Comment
1	4960.000	55.16	-10.19	44.97	74.00	-29.03	peak	
2 *	4960.000	42.45	-10.19	32.26	54.00	-21.74	AVG	

**REMARKS:**

- (1) Measurement Value = Reading Level + Correct Factor.
- (2) Margin Level = Measurement Value - Limit Value.

Test Mode	TX Mode 2480MHz _CH39_1Mbps	Tested Date	2019/12/9
Test Voltage	DC 48V	Polarization	Horizontal

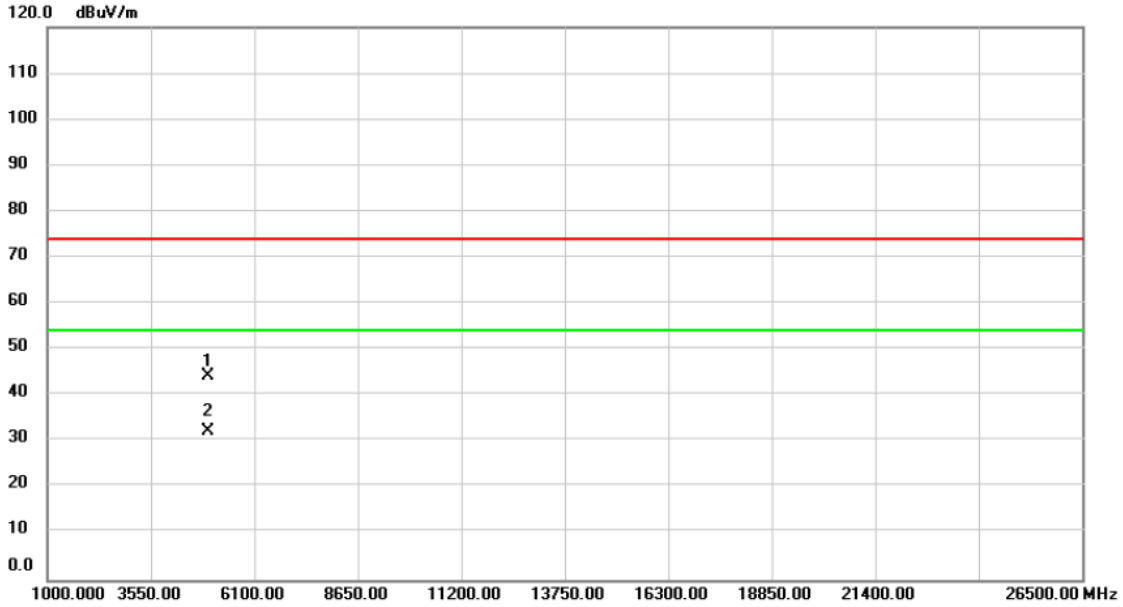

No. Mk.	Freq. MHz	Reading Level dBuV	Correct Factor dB	Measure- ment dBuV/m	Limit dBuV/m	Margin dB	Detector	Comment
1	4960.000	54.37	-10.19	44.18	74.00	-29.82	peak	
2 *	4960.000	42.53	-10.19	32.34	54.00	-21.66	AVG	

**REMARKS:**

- (1) Measurement Value = Reading Level + Correct Factor.
- (2) Margin Level = Measurement Value - Limit Value.

# APPENDIX D BANDWIDTH

Test Mode:	TX Mode _1Mbps
Test Voltage	DC 48V

Frequency (MHz)	6dB Bandwidth (MHz)	99% Occupied BW (MHz)	Min. Limit (kHz)	Test Result
2402	0.68	1.08	500	Pass
2440	0.66	1.08	500	Pass
2480	0.68	1.08	500	Pass

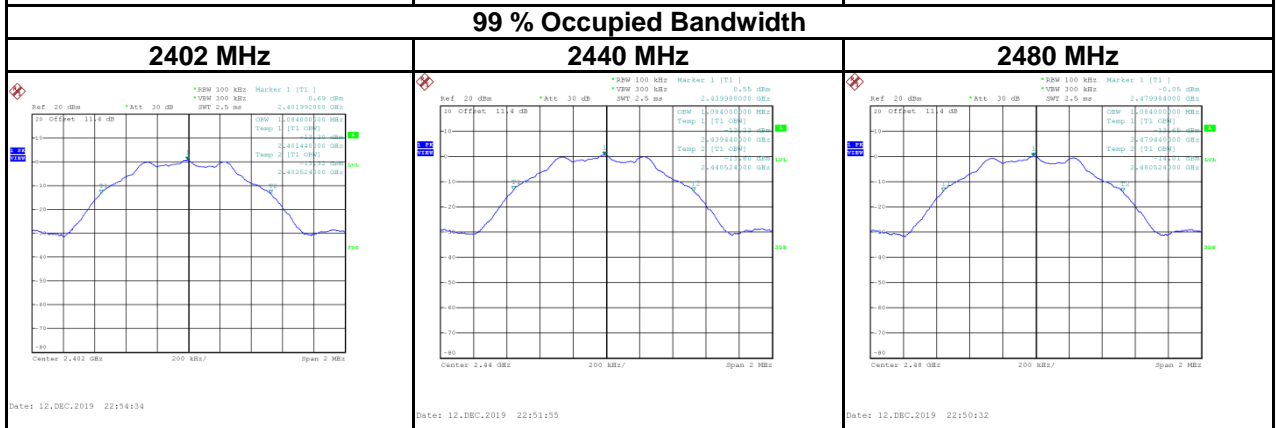
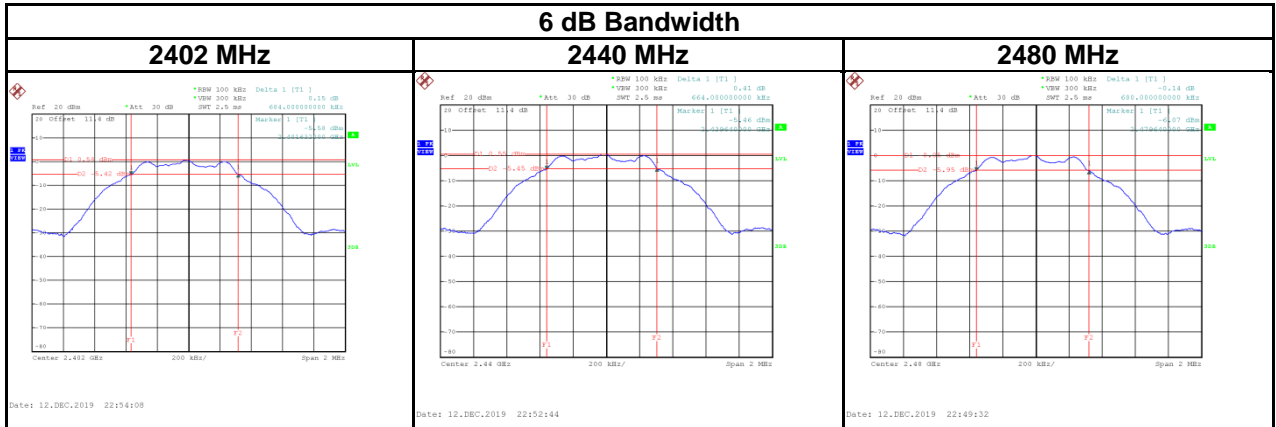



# APPENDIX E OUTPUT POWER

Test Mode :	TX Mode _1Mbps	Tested Date	2019/12/5
Test Voltage	DC 48V		

Frequency (MHz)	Conducted Power (dBm)	Conducted Power (W)	Max. Limit (dBm)	Max. Limit (W)	Test Result
2402	1.63	0.0015	30.00	1.0000	Pass
2440	1.43	0.0014	30.00	1.0000	Pass
2480	0.95	0.0012	30.00	1.0000	Pass

## **APPENDIX F POWER SPECTRAL DENSITY TEST**

Test Mode:	TX Mode _1Mbps
Test Voltage	DC 48V

Frequency (MHz)	Power Density (dBm/3kHz)	Max. Limit (dBm/3kHz)	Test Result
2402	-15.62	8.00	Pass
2440	-16.20	8.00	Pass
2480	-15.68	8.00	Pass

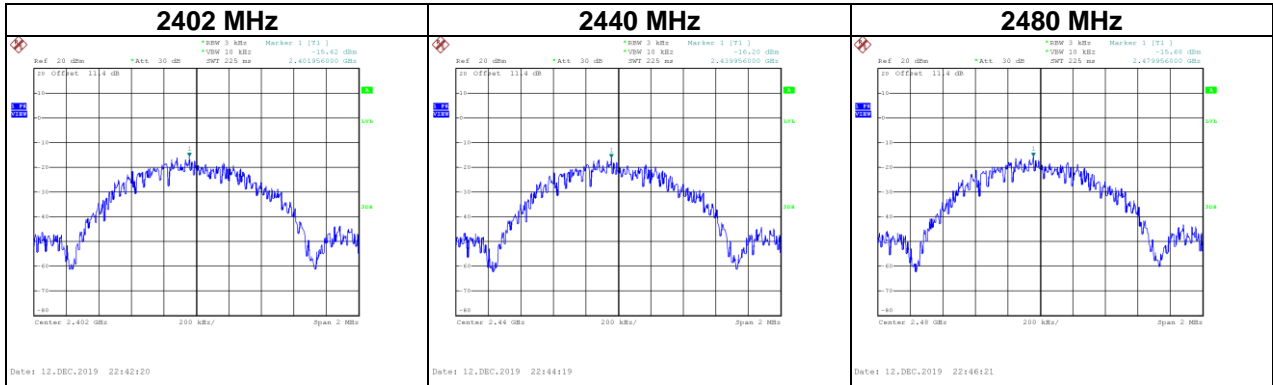

## **APPENDIX G ANTENNA CONDUCTED SPURIOUS EMISSION**

Test Mode :	TX Mode_1Mbps
Test Voltage	DC 48V

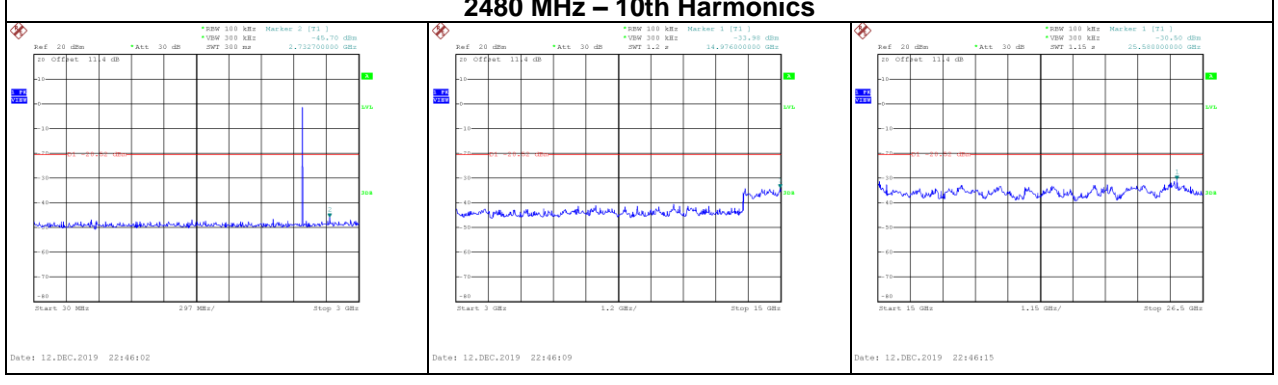
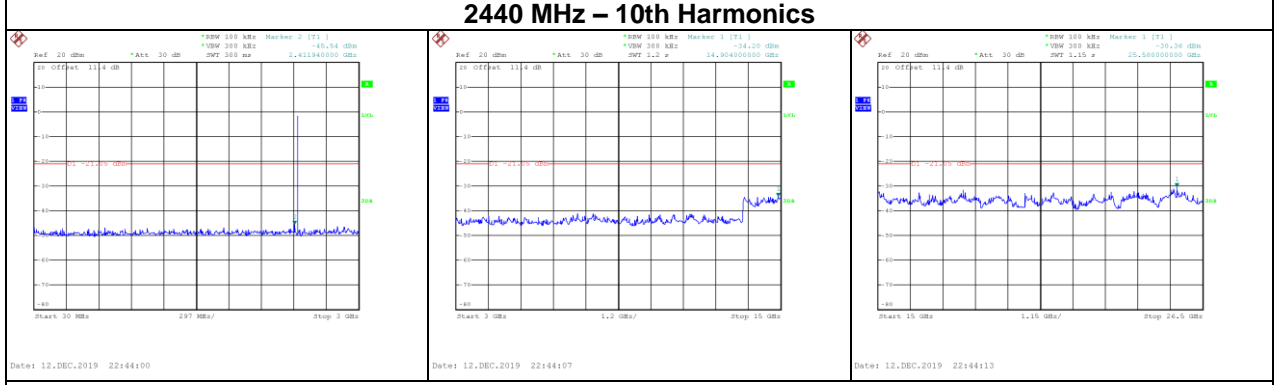
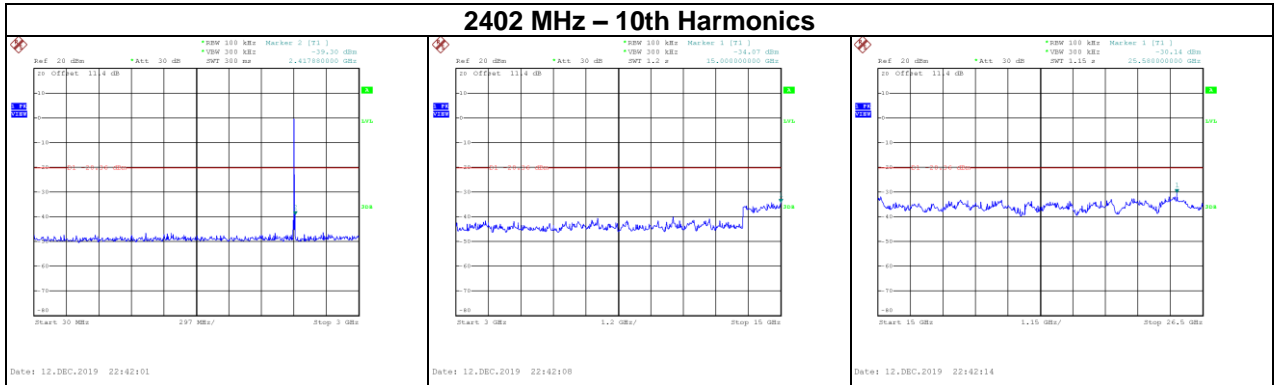
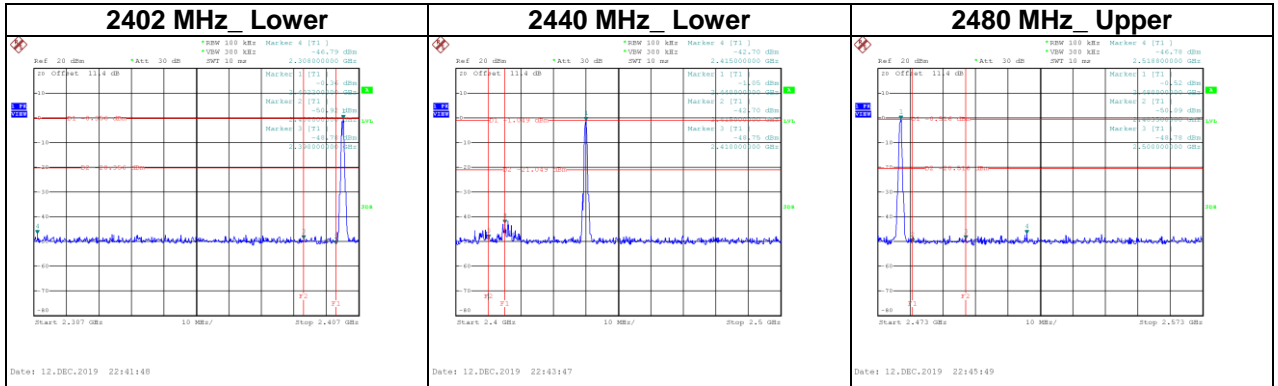

End of Test Report