

# FCC Radio Test Report

**FCC ID: EROTS770**

**Report No.** : BTL-FCCP-4-2004T143  
**Equipment** : 7 inch Touch Screen Surface mount  
**Model Name** : M201923005, TS-770-B-S, TS-770-W-S  
**Brand Name** : CRESTRON  
**Applicant** : Crestron Electronics, Inc.  
**Address** : 15 Volvo Drive, Rockleigh, NJ 07647

**Radio Function** : RLAN 5 GHz (U-NII 1, U-NII 3)

**FCC Rule Part(s)** : FCC Part15, Subpart E (15.407)  
**Measurement Procedure(s)** : ANSI C63.10-2013

**Date of Receipt** : 2020/4/27  
**Date of Test** : 2020/4/27 ~ 2020/5/11  
**Issued Date** : 2020/5/27

The above equipment has been tested and found in compliance with the requirement of the above standards by BTL Inc.

**Prepared by** :

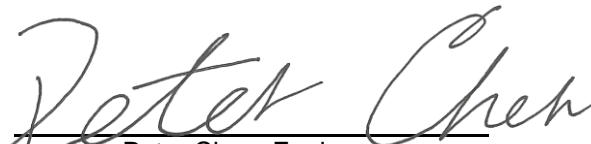
  
Peter Chen, Engineer



**Approved by** :

  
Scott Hsu, Manager

**BTL Inc.**

No.18, Ln. 171, Sec. 2, Jiuzong Rd., Neihu Dist., Taipei City 114, Taiwan

Tel: +886-2-2657-3299

Fax: +886-2-2657-3331

Web: www.newbtl.com

**Declaration**

**BTL** represents to the client that testing is done in accordance with standard procedures as applicable and that test instruments used has been calibrated with standards traceable to international standard(s) and/or national standard(s).

**BTL's** reports apply only to the specific samples tested under conditions. It is manufacture's responsibility to ensure that additional production units of this model are manufactured with the identical electrical and mechanical components. **BTL** shall have no liability for any declarations, inferences or generalizations drawn by the client or others from **BTL** issued reports.

The report must not be used by the client to claim product certification, approval, or endorsement by NIST, A2LA, or any agency of the U.S. Government.

This report is the confidential property of the client. As a mutual protection to the clients, the public and ourselves, the test report shall not be reproduced, except in full, without our written approval.

**BTL's** laboratory quality assurance procedures are in compliance with the **ISO/IEC 17025** requirements, and accredited by the conformity assessment authorities listed in this test report.

**BTL** is not responsible for the sampling stage, so the results only apply to the sample as received.

The information, data and test plan are provided by manufacturer which may affect the validity of results, so it is manufacturer's responsibility to ensure that the apparatus meets the essential requirements of applied standards and in all the possible configurations as representative of its intended use.

**Limitation**

For the use of the authority's logo is limited unless the Test Standard(s)/Scope(s)/Item(s) mentioned in this test report is (are) included in the conformity assessment authorities acceptance respective.

Please note that the measurement uncertainty is provided for informational purpose only and are not use in determining the Pass/Fail results.

**CONTENTS**

REPORT ISSUED HISTORY	5
1 SUMMARY OF TEST RESULTS	6
1.1 TEST FACILITY	7
1.2 MEASUREMENT UNCERTAINTY	7
1.3 TEST ENVIRONMENT CONDITIONS	8
1.4 TABLE OF PARAMETERS OF TEXT SOFTWARE SETTING	8
1.5 DUTY CYCLE	9
2 GENERAL INFORMATION	11
2.1 DESCRIPTION OF EUT	11
2.2 TEST MODES	13
2.3 BLOCK DIAGRAM SHOWING THE CONFIGURATION OF SYSTEM TESTED	14
2.4 SUPPORT UNITS	14
3 RADIATED EMISSIONS TEST	15
3.1 LIMIT	15
3.2 TEST PROCEDURE	16
3.3 DEVIATION FROM TEST STANDARD	16
3.4 TEST SETUP	17
3.5 EUT OPERATING CONDITIONS	18
3.6 TEST RESULT – 30 MHZ TO 1 GHZ	18
3.7 TEST RESULT – ABOVE 1 GHZ	18
4 BANDWIDTH TEST	19
4.1 LIMIT	19
4.2 TEST PROCEDURE	19
4.3 DEVIATION FROM TEST STANDARD	19
4.4 TEST SETUP	19
4.5 EUT OPERATING CONDITIONS	19
4.6 TEST RESULT	19
5 OUTPUT POWER TEST	20
5.1 LIMIT	20
5.2 TEST PROCEDURE	20
5.3 DEVIATION FROM TEST STANDARD	20
5.4 TEST SETUP	20
5.5 EUT OPERATING CONDITIONS	20
5.6 TEST RESULT	20
6 POWER SPECTRAL DENSITY	21
6.1 LIMIT	21
6.2 TEST PROCEDURE	21
6.3 DEVIATION FROM TEST STANDARD	21
6.4 TEST SETUP	21
6.5 EUT OPERATING CONDITIONS	21
6.6 TEST RESULT	21
7 LIST OF MEASURING EQUIPMENTS	22
8 EUT TEST PHOTO	23
9 EUT PHOTOS	23
APPENDIX A RADIATED EMISSIONS - 30 MHZ TO 1 GHZ	24
APPENDIX B RADIATED EMISSIONS - ABOVE 1 GHZ	27

APPENDIX C	BANDWIDTH	78
APPENDIX D	CONDUCTED OUTPUT POWER	86
APPENDIX E	POWER SPECTRAL DENSITY	90

### REPORT ISSUED HISTORY

Report Version	Description	Issued Date
R00	Original Issue.	2020/5/27

# 1 SUMMARY OF TEST RESULTS

Test procedures according to the technical standards.

FCC Part 15, Subpart E (15.407)				
Standard(s) Section	Description	Test Result	Judgement	Remark
15.207	AC Power Line Conducted Emissions	-----	N/A	NOTE(4)
15.205 15.209 15.407(b)	Radiated Emissions	APPENDIX A APPENDIX B	Pass	-----
15.407(a)	Bandwidth	APPENDIX C	Pass	-----
15.407(a)	Output Power	APPENDIX D	Pass	-----
15.407(a)	Power Spectral Density	APPENDIX E	Pass	-----
15.203	Antenna Requirement	-----	Pass	-----
15.407(c)	Automatically Discontinue Transmission	-----	Pass	<b>NOTE (2)</b>

**NOTE:**

- (1) "N/A" denotes test is not applicable in this Test Report.
- (2) The EUT can detect the controlling signal of ACK message transmitting from remote device and verify whether it shall resend or discontinue transmission.
- (3) The report format version is TP.1.1.1.
- (4) Input power is supplied by POE.

### 1.1 TEST FACILITY

The test facilities used to collect the test data in this report:

No. 68-1, Ln. 169, Sec. 2, Datong Rd., Xizhi Dist., New Taipei City 221, Taiwan

The test sites and facilities are covered under FCC RN: 674415 and DN: TW0659.

- C05       CB08       CB11       CB15       CB16  
 SR06

No.18, Ln. 171, Sec. 2, Jiuzong Rd., Neihu Dist., Taipei City 114, Taiwan

The test sites and facilities are covered under FCC RN: 325517 and DN: TW1115.

- C03       CB18       CB19

### 1.2 MEASUREMENT UNCERTAINTY

The reported uncertainty of measurement  $y \pm U$ , where expanded uncertainty  $U$  is based on a standard uncertainty multiplied by a coverage factor of  $k = 2$ , providing a level of confidence of approximately **95 %**. The measurement instrumentation uncertainty considerations contained in CISPR 16-4-2. The BTL measurement uncertainty is less than the CISPR 16-4-2  $U_{cispr}$  requirement.

#### A. Radiated emissions test :

Test Site	Measurement Frequency Range	$U, (dB)$
CB15	0.03 GHz ~ 0.2 GHz	4.17
	0.2 GHz ~ 1 GHz	4.72
	1 GHz ~ 6 GHz	5.21
	6 GHz ~ 18 GHz	5.51
	18 GHz ~ 26 GHz	3.69
	26 GHz ~ 40 GHz	4.23

#### B. Conducted test :

Test Item	$U, (dB)$
Bandwidth	1.13
Output power	1.07
Power Spectral Density	1.20
Conducted Band edges	1.13
Frequency Stability	1.13

#### NOTE:

Unless specifically mentioned, the uncertainty of measurement has not been taken into account to declare the compliance or non-compliance to the specification.

**1.3 TEST ENVIRONMENT CONDITIONS**

Test Item	Environment Condition	Test Voltage	Tested by
Radiated emissions below 1 GHz	22 °C, 65 %	DC 48V	Hunter Chiang
Radiated emissions above 1 GHz	22 °C, 65 %	DC 48V	Hunter Chiang
Bandwidth	23.8 °C, 54 %	DC 48V	Jay Kao
Output Power	23.8 °C, 54 %	DC 48V	Jay Kao
Power Spectral Density	23.8 °C, 54 %	DC 48V	Jay Kao

**1.4 TABLE OF PARAMETERS OF TEXT SOFTWARE SETTING**

UNII-1				
Test Software	QRCT 4.0.00093			
Mode	5180 MHz	5200 MHz	5240 MHz	Data Rate
IEEE 802.11a	13	14	14	6 Mbps
IEEE 802.11n (HT20)	13	14	14	MCS 0
IEEE 802.11ac (VHT20)	13	14	14	MCS 0
Mode	5190 MHz	5230 MHz		Data Rate
IEEE 802.11n (HT40)	9	14		MCS 0
IEEE 802.11ac (VHT40)	9	14		MCS 0
Mode	5210 MHz			Data Rate
IEEE 802.11ac (VHT80)	9			MCS 0

UNII-3				
Test Software	QRCT 4.0.00093			
Mode	5745 MHz	5785 MHz	5825 MHz	Data Rate
IEEE 802.11a	13	13	13	6 Mbps
IEEE 802.11n (HT20)	13	13	13	MCS 0
IEEE 802.11ac (VHT20)	13	13	13	MCS 0
Mode	5755 MHz	5795 MHz		Data Rate
IEEE 802.11n (HT40)	13	13		MCS 0
IEEE 802.11ac (VHT40)	13	13		MCS 0
Mode	5775 MHz			Data Rate
IEEE 802.11ac (VHT80)	14			MCS 0



## 1.5 DUTY CYCLE

If duty cycle is  $\geq 98\%$ , duty factor is not required.

If duty cycle is  $< 98\%$ , duty factor shall be considered.

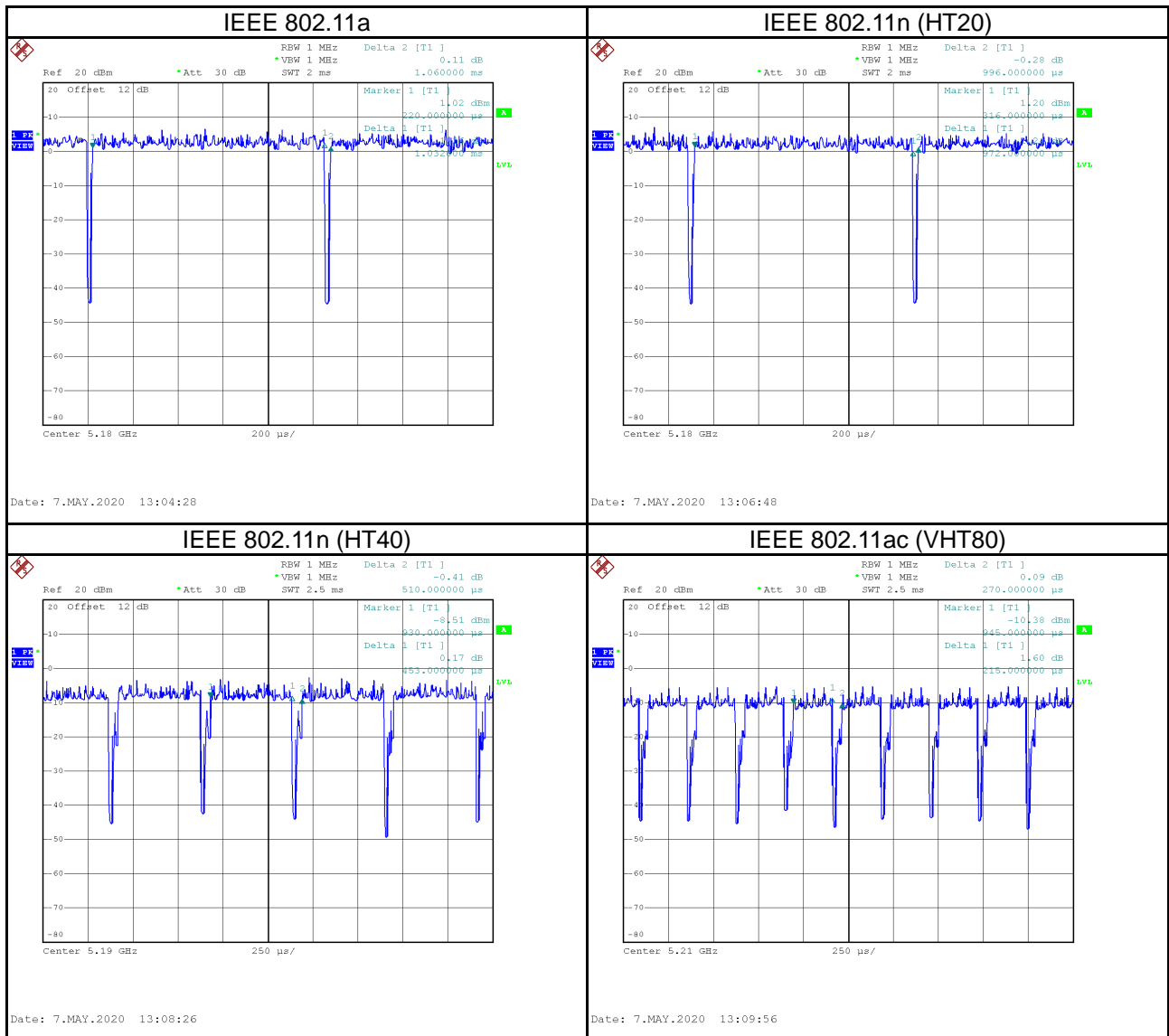

Remark	Delta 1			Delta 2	On Time/Period	10 log(1/Duty Cycle)
Mode	ON (ms)	Numbers (ON)	On Time (B) (ms)	Period (ON+OFF) (ms)	Duty Cycle (%)	Duty Factor (dB)
IEEE 802.11a	1.032	1	1.032	1.060	97.36%	0.12
IEEE 802.11n (HT20)	0.972	1	0.972	0.996	97.59%	0.11
IEEE 802.11n (HT40)	0.453	1	0.453	0.510	88.82%	0.51
IEEE 802.11ac (VHT80)	0.215	1	0.215	0.270	79.63%	0.99

**NOTE:**

For IEEE 802.11a, IEEE 802.11n (HT20):

For radiated emissions frequency above 1 GHz, the resolution bandwidth of test receiver/spectrum analyzer is 1 MHz and the video bandwidth is 1.5 kHz (Duty cycle < 98%).

For IEEE 802.11n (HT40):

For radiated emissions frequency above 1 GHz, the resolution bandwidth of test receiver/spectrum analyzer is 1 MHz and the video bandwidth is 2.2 kHz (Duty cycle < 98%).

For IEEE 802.11ac (VHT80):

For radiated emissions frequency above 1 GHz, the resolution bandwidth of test receiver/spectrum analyzer is 1 MHz and the video bandwidth is 4 kHz (Duty cycle < 98%).

## 2 GENERAL INFORMATION

### 2.1 DESCRIPTION OF EUT

Equipment	7 inch Touch Screen Surface mount
Model Name	M201923005, TS-770-B-S, TS-770-W-S
Brand Name	CRESTRON
Model Difference	M201923005 includes two series: TS-770-B-S, TS-770-W-S All modes are identical to each other except below: B: Black, W: White, S: Smooth
Power Source	DC voltage supplied from POE.
Power Rating	I/P: 48 VDC 350mA (802.3at type 1), 48 VDC 600mA (802.3at type 2)
Products Covered	N/A
Frequency Range	UNII-1: 5150 MHz to 5250 MHz UNII-3: 5725 MHz to 5850 MHz
Operation Frequency	UNII-1: 5180 MHz to 5240 MHz UNII-3: 5745 MHz to 5825 MHz
Modulation Technology	OFDM
Transfer Rate	up to 433.3 Mbps
Output Power Max. for UNII-1	IEEE 802.11a: 13.56 dBm (0.0227 W) IEEE 802.11n (HT20): 13.67 dBm (0.0233 W) IEEE 802.11n (HT40): 13.72 dBm (0.0236 W) IEEE 802.11ac (VHT20): 13.58 dBm (0.0228 W) IEEE 802.11ac (VHT40): 13.63 dBm (0.0231 W) IEEE 802.11ac (VHT80): 8.97 dBm (0.0079 W)
Output Power Max. for UNII-3	IEEE 802.11a: 19.18 dBm (0.0828 W) IEEE 802.11n (HT20): 19.27 dBm (0.0845 W) IEEE 802.11n (HT40): 19.36 dBm (0.0863 W) IEEE 802.11ac (VHT20): 19.17 dBm (0.0826 W) IEEE 802.11ac (VHT40): 19.22 dBm (0.0836 W) IEEE 802.11ac (VHT80): 19.42 dBm (0.0875 W)
Test Model	M201923005
Sample Status	Engineering Sample
EUT Modification(s)	N/A

**NOTE:**

- (1) For a more detailed features description, please refer to the manufacturer's specifications or the user's manual.

## (2) Channel List:

UNII-1					
IEEE 802.11a IEEE 802.11n (HT20) IEEE 802.11ac (VHT20)		IEEE 802.11n (HT40) IEEE 802.11ac (VHT40)		IEEE 802.11ac (VHT80)	
Channel	Frequency (MHz)	Channel	Frequency (MHz)	Channel	Frequency (MHz)
36	5180	38	5190	42	5210
40	5200	46	5230		
44	5220				
48	5240				

UNII-3					
IEEE 802.11a IEEE 802.11n (HT20) IEEE 802.11ac (VHT20)		IEEE 802.11n (HT40) IEEE 802.11ac (VHT40)		IEEE 802.11ac (VHT80)	
Channel	Frequency (MHz)	Channel	Frequency (MHz)	Channel	Frequency (MHz)
149	5745	151	5755	155	5775
153	5765	159	5795		
157	5785				
161	5805				
165	5825				

## (3) Table for Filed Antenna:

Ant.	Brand	Model Name	Antenna Type	Connector	Gain (dBi)	Note
1	YAGEO	TS WLAN MAIN	PIFA	IPEX	1.86	UNII-1
					4.17	UNII-3

**2.2 TEST MODES**

Test Items	Test mode	Channel	Note
Transmitter Radiated Emissions (below 1GHz)	TX Mode_IEEE 802.11n (HT20)	165	-
Transmitter Radiated Emissions (above 1GHz)	TX Mode_IEEE 802.11a	36/48	Bandedge
	TX Mode_IEEE 802.11n (HT20)	149/165	
	TX Mode_IEEE 802.11ac (VHT40)	38/46 151/159	
	TX Mode_IEEE 802.11ac (VHT80)	42 155	
Transmitter Radiated Emissions (above 1GHz)	TX Mode_IEEE 802.11a	36/40/48	Harmonic
	TX Mode_IEEE 802.11n (HT20)	149/157/165	
	TX Mode_IEEE 802.11ac (VHT40)	38/46 151/159	-
	TX Mode_IEEE 802.11ac (VHT80)	42 155	
Bandwidth	TX Mode_IEEE 802.11a	36/40/48	-
	TX Mode_IEEE 802.11n (HT20)	149/157/165	
	TX Mode_IEEE 802.11n (HT40)	38/46 151/159	
	TX Mode_IEEE 802.11ac (VHT80)	42 155	
Output Power	TX Mode_IEEE 802.11a	36/40/48 149/157/165	-
	TX Mode_IEEE 802.11n (HT20)		
	TX Mode_IEEE 802.11ac (VHT20)		
	TX Mode_IEEE 802.11n (HT40)	38/46	
	TX Mode_IEEE 802.11ac (VHT40)	151/159	
Power Spectral Density	TX Mode_IEEE 802.11a	36/40/48 149/157/165	-
	TX Mode_IEEE 802.11n (HT20)		
	TX Mode_IEEE 802.11n (HT40)	38/46 151/159	
	TX Mode_IEEE 802.11ac (VHT80)	42 155	

**NOTE:**

- (1) The Radiated emissions test was verified based on the worst conducted power and Bandwidth test results reported in the original report.
- (2) For radiated emission band edge test, both Vertical and Horizontal are evaluated, but only the worst case (Vertical) is recorded.
- (3) All X, Y and Z axes are evaluated, but only the worst case (X axis) is recorded.
- (4) There were no emissions found below 30 MHz within 20 dB of the limit.

### 2.3 BLOCK DIAGRAM SHOWING THE CONFIGURATION OF SYSTEM TESTED

Equipment letters and Cable numbers refer to item numbers described in the tables of clause 2.4.

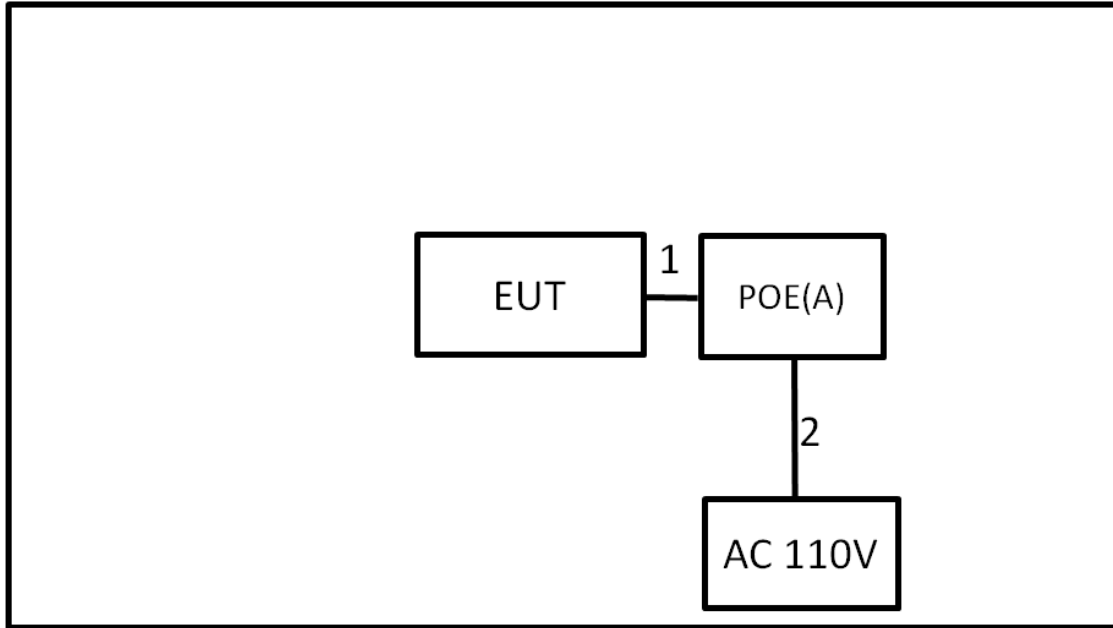

### 2.4 SUPPORT UNITS

Item	Equipment	Brand	Model No.	Series No.	Remarks
A	MANAGED POE SWITCH	CRESTRON	CEN-SWPOE-16	N/A	Supplied by test requester.

Item	Shielded	Ferrite Core	Length	Cable Type	Remarks
1	YES	NO	2m	RJ45	Supplied by test requester.
2	NO	NO	1m	Power Cable	Furnished by test lab.

### 3 RADIATED EMISSIONS TEST

#### 3.1 LIMIT

In case the emission fall within the restricted band specified on 15.205, then the 15.209 limit in the table below has to be followed.

#### LIMITS OF RADIATED EMISSIONS MEASUREMENT (9 kHz to 1000 MHz)

Frequency (MHz)	Field Strength (microvolts/meter)	Measurement Distance (meters)
0.009~0.490	2400/F(KHz)	300
0.490~1.705	24000/F(KHz)	30
1.705~30.0	30	30
30~88	100	3
88~216	150	3
216~960	200	3
960~1000	500	3

#### LIMITS OF UNWANTED EMISSION OUT OF THE RESTRICTED BANDS

Frequency (MHz)	EIRP Limit (dBm)	Equivalent Field Strength at 3m (dBµV/m)
5150-5250	-27	68.3
5250-5350	-27	68.3
5470-5725	-27	68.3
5725-5850	-27 (NOTE 2)	68.3
	10 (NOTE 2)	105.3
	15.6 (NOTE 2)	110.9
	27 (NOTE 2)	122.3

#### NOTE:

(1) The following formula is used to convert the equipment isotropic radiated power (eirp) to field strength:

$$E = \frac{1000000\sqrt{30P}}{3} \mu\text{V/m, where P is the eirp (Watts)}$$

(2) According to FCC 16-24, All emissions shall be limited to a level of -27 dBm/MHz at 75 MHz or more above or below the band edge increasing linearly to 10 dBm/MHz at 25 MHz above or below the band edge, and from 25 MHz above or below the band edge increasing linearly to a level of 15.6 dBm/MHz at 5 MHz above or below the band edge, and from 5 MHz above or below the band edge increasing linearly to a level of 27 dBm/MHz at the band edge.

(3) The test result calculated as following:

Measurement Value = Reading Level + Correct Factor

Correct Factor = Antenna Factor + Cable Loss - Amplifier Gain(if use)

Margin Level = Measurement Value - Limit Value

Calculation example:

Reading Level		Correct Factor		Measurement Value
19.11	+	2.11	=	21.22

Measurement Value		Limit Value		Margin Level
21.22	-	68.3	=	-47.08

Spectrum Parameter	Setting
Attenuation	Auto
Start Frequency	1000 MHz
Stop Frequency	10th carrier harmonic
RBW / VBW (Emission in restricted band)	1MHz / 3MHz for Peak, 1MHz / 1/T for Average

Spectrum Parameter	Setting
Attenuation	Auto
Start ~ Stop Frequency	9KHz~90KHz for PK/AVG detector
Start ~ Stop Frequency	90KHz~110KHz for QP detector
Start ~ Stop Frequency	110KHz~490KHz for PK/AVG detector
Start ~ Stop Frequency	490KHz~30MHz for QP detector
Start ~ Stop Frequency	30MHz~1000MHz for QP detector

### 3.2 TEST PROCEDURE

- a. The measuring distance of 3 m shall be used for measurements. The EUT was placed on the top of a rotating table 0.8 meter above the ground at a 3 meter semi-anechoic chamber. The table was rotated 360 degrees to determine the position of the highest radiation.(below 1GHz)
- b. The measuring distance of 3 m shall be used for measurements. The EUT was placed on the top of a rotating table 1.5 meter above the ground at a 3 meter semi-anechoic chamber. The table was rotated 360 degrees to determine the position of the highest radiation.(above 1GHz)
- c. The height of the equipment or of the substitution antenna shall be 0.8 m or 1.5 m, the height of the test antenna shall vary between 1 m to 4 m. Both horizontal and vertical polarizations of the antenna are set to make the measurement.
- d. For each suspected emission, the EUT was arranged to its worst case and then the antenna was tuned to heights find the maximum reading (used Bore sight function).
- e. The receiver system was set to peak and average detect function and specified bandwidth with maximum hold mode when the test frequency is above 1GHz.
- f. The initial step in collecting radiated emission data is a receiver peak detector mode pre-scanning the measurement frequency range. Significant peaks are then marked and then Quasi Peak detector mode re-measured.
- g. All readings are Peak unless otherwise stated QP in column of Note. Peak denotes that the Peak reading compliance with the QP Limits and then QP Mode measurement didn't perform. (below 1GHz)
- h. All readings are Peak Mode value unless otherwise stated AVG in column of Note. If the Peak Mode Measured value compliance with the Peak Limits and lower than AVG Limits, the EUT shall be deemed to meet both Peak & AVG Limits and then only Peak Mode was measured, but AVG Mode didn't perform. (above 1GHz)
- i. For the actual test configuration, please refer to the related Item – EUT TEST PHOTO.

### 3.3 DEVIATION FROM TEST STANDARD

No deviation.



### 3.4 TEST SETUP

9 kHz to 30 MHz

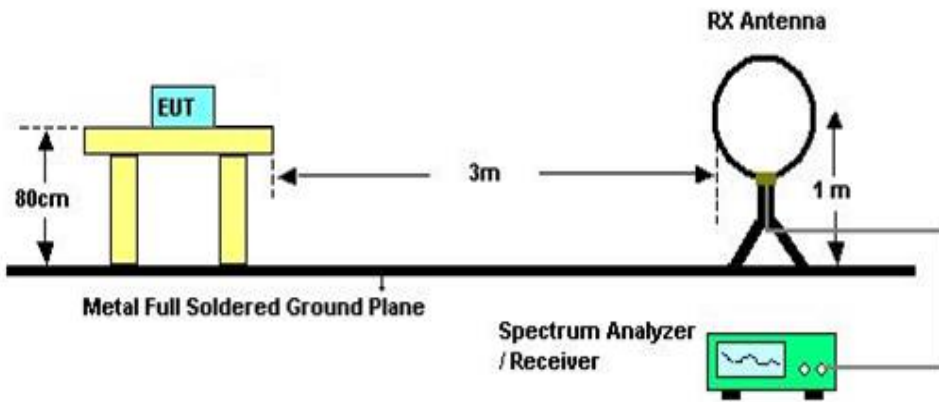

30 MHz to 1 GHz

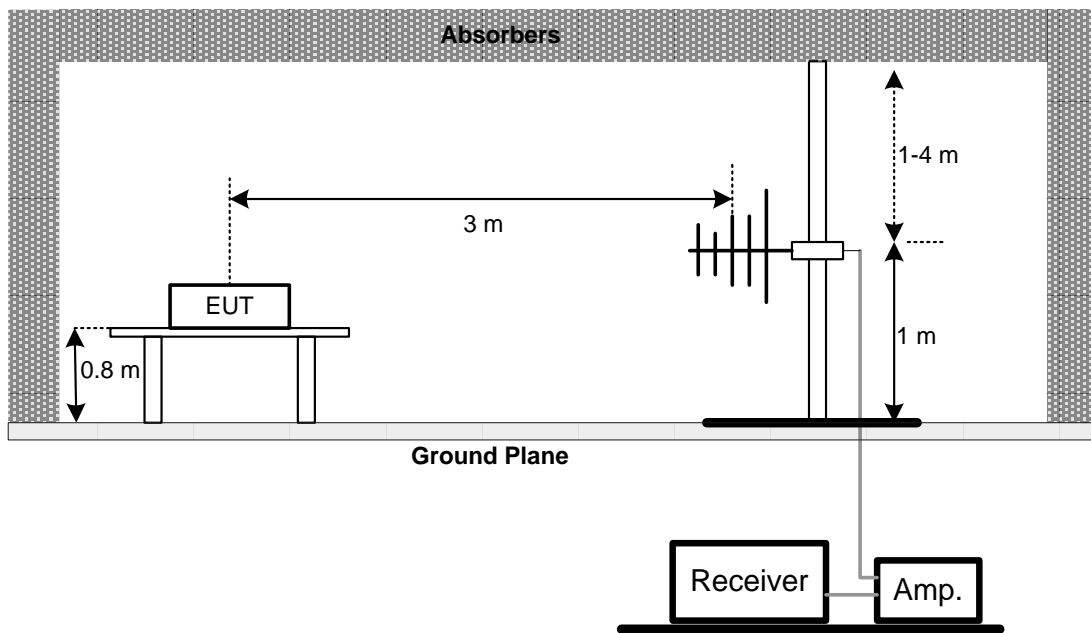

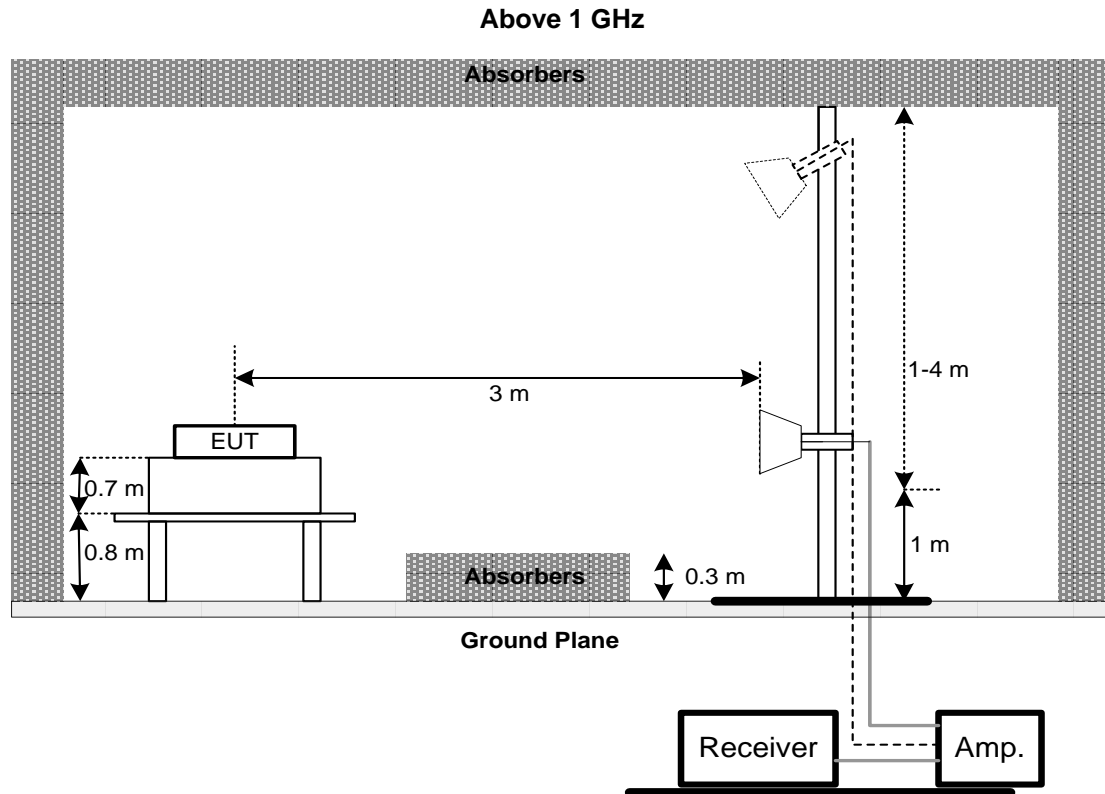

### 3.5 EUT OPERATING CONDITIONS

The EUT was programmed to be in continuously transmitting mode.

### 3.6 TEST RESULT – 30 MHZ TO 1 GHZ

Please refer to the APPENDIX A.

### 3.7 TEST RESULT – ABOVE 1 GHZ

Please refer to the APPENDIX B.

#### NOTE:

- (1) No limit: This is fundamental signal, the judgment is not applicable.  
For fundamental signal judgment was referred to Peak output test.

## 4 BANDWIDTH TEST

### 4.1 LIMIT

FCC Part15, Subpart E (15.407)		
Section	Test Item	Frequency Range (MHz)
15.407(a)	26 dB Bandwidth	5150-5250
		5250-5350
		5470-5725
	Minimum 500 kHz 6 dB Bandwidth	5725-5850

### 4.2 TEST PROCEDURE

- a. The EUT was directly connected to the spectrum analyzer and antenna output port as show in the block diagram below.
- b. Spectrum Setting:

Spectrum Parameter	Setting
Attenuation	Auto
Span Frequency	> 26 dB Bandwidth
RBW	300 kHz(Bandwidth 20 MHz) 1 MHz(Bandwidth 40 MHz and 80 MHz)
VBW	1 MHz(Bandwidth 20 MHz) 3 MHz(Bandwidth 40 MHz and 80 MHz)
Detector	Peak
Trace	Max Hold
Sweep Time	Auto

### 4.3 DEVIATION FROM TEST STANDARD

No deviation.

### 4.4 TEST SETUP

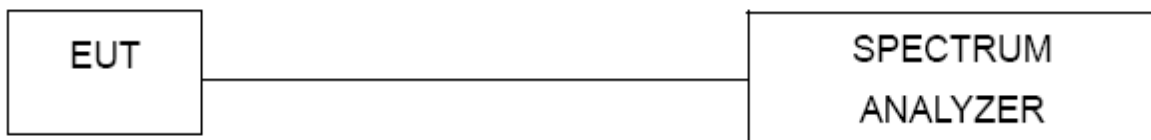

### 4.5 EUT OPERATING CONDITIONS

The EUT was programmed to be in continuously transmitting mode.

### 4.6 TEST RESULT

Please refer to the APPENDIX C.

## 5 OUTPUT POWER TEST

### 5.1 LIMIT

FCC Part15, Subpart E (15.407)			
Section	Test Item	Limit	Frequency Range (MHz)
15.407(a)	Maximum Output Power	Fixed:1 Watt (30 dBm) Mobile and portable: 250 mW (24 dBm)	5150-5250
		250 mW (24 dBm)	5250-5350
		1 Watt (30dBm)	5470-5725 5725-5850

Note: The maximum e.i.r.p at any elevation angle above 30 degrees as measured from the horizon must not exceed 125 mW(21 dBm).

### 5.2 TEST PROCEDURE

- a. The EUT was directly connected to the power meter and antenna output port as show in the block diagram below.
- b. Spectrum Setting:

Spectrum Parameter	Setting
Attenuation	Auto
Span Frequency	Encompass the entire emissions bandwidth (EBW) of the signal
RBW	= 1 MHz
VBW	≥ 3 MHz
Detector	RMS
Trace	Max Hold
Sweep Time	auto

- c. The maximum peak conducted output power was performed in accordance with method of FCC KDB 789033 D02 General UNII Test Procedures New Rules v02r01.

### 5.3 DEVIATION FROM TEST STANDARD

No deviation.

### 5.4 TEST SETUP



### 5.5 EUT OPERATING CONDITIONS

The EUT was programmed to be in continuously transmitting mode.

### 5.6 TEST RESULT

Please refer to the APPENDIX D.

## 6 POWER SPECTRAL DENSITY

### 6.1 LIMIT

FCC Part15, Subpart E (15.407)			
Section	Test Item	Limit	Frequency Range (MHz)
15.407(a)	Power Spectral Density	Other than Mobile and portable: 17 dBm/MHz Mobile and portable: 11 dBm/MHz	5150-5250
		11 dBm/MHz	5250-5350
		30 dBm/500 kHz	5470-5725
			5725-5850

### 6.2 TEST PROCEDURE

- a. The EUT was directly connected to the spectrum analyzer and antenna output port as show in the block diagram below.
- b. Spectrum Setting:

Spectrum Parameter	Setting
Attenuation	Auto
Span Frequency	Encompass the entire emissions bandwidth (EBW) of the signal
RBW	= 1 MHz
VBW	≥ 3 MHz
Detector	RMS
Trace	Max Hold
Sweep Time	Auto

### 6.3 DEVIATION FROM TEST STANDARD

No deviation.

### 6.4 TEST SETUP



### 6.5 EUT OPERATING CONDITIONS

The EUT was programmed to be in continuously transmitting mode.

### 6.6 TEST RESULT

Please refer to the APPENDIX E.

## 7 LIST OF MEASURING EQUIPMENTS

Radiated Emissions						
Item	Kind of Equipment	Manufacturer	Type No.	Serial No.	Calibrated Date	Calibrated Until
1	Preamplifier	EMCI	EMC001340	980555	2020/2/28	2021/2/27
2	Preamplifier	EMCI	EMC02325B	980217	2020/4/10	2021/4/9
3	Preamplifier	EMCI	EMC012645B	980267	2020/4/10	2021/4/9
4	Preamplifier	EMCI	EMC2654045	980030	2020/1/31	2021/1/30
5	Test Cable	EMCI	EMC104-SM-SM-800	150207	2020/4/10	2021/4/9
6	Test Cable	EMCI	EMC104-SM-SM-3000	151205	2020/4/10	2021/4/9
7	Test Cable	EMCI	EMC-SM-SM-7000	180408	2020/4/10	2021/4/9
8	MXE EMI Receiver	Agilent	N9038A	MY55420127	2020/3/24	2021/3/24
9	Signal Analyzer	Agilent	N9010A	MY56480554	2019/6/6	2020/6/5
10	Loop Ant	EMCO	EMCI-LPA600	274	2019/5/31	2020/5/30
11	Horn Ant	SCHWARZBECK	BBHA 9120D	9120D-1342	2019/6/10	2020/6/9
12	Horn Ant	Schwarzbeck	BBHA 9170	187	2019/12/21	2020/12/20
13	Trilog-Broadband Antenna	Schwarzbeck	VULB 9168	000992	2019/5/29	2020/5/28
14	5dB Attenuator	EMCI	EMCI-N-6-05	AT-N0508	2019/5/29	2020/5/28

Bandwidth						
Item	Kind of Equipment	Manufacturer	Type No.	Serial No.	Calibrated Date	Calibrated Until
1	Spectrum Analyzer	R&S	FSP40	100129	2019/5/23	2020/5/22

Output Power						
Item	Kind of Equipment	Manufacturer	Type No.	Serial No.	Calibrated Date	Calibrated Until
1	Power Meter	Anritsu	ML2487A	6K00004714	2019/6/20	2020/6/19
2	Power Sensor	Anritsu	MA2491A	1725282	2019/6/20	2020/6/19

Power Spectral Density						
Item	Kind of Equipment	Manufacturer	Type No.	Serial No.	Calibrated Date	Calibrated Until
1	Spectrum Analyzer	R&S	FSP40	100129	2019/5/23	2020/5/22

Remark: "N/A" denotes no model name, no serial no. or no calibration specified.  
All calibration period of equipment list is one year.

**8 EUT TEST PHOTO**

Please refer to document Appendix No.: TP-2004T143-FCCP-1 (APPENDIX-TEST PHOTOS).

**9 EUT PHOTOS**

Please refer to document Appendix No.: EP-2004T143-1 (APPENDIX-EUT PHOTOS).

## **APPENDIX A    RADIATED EMISSIONS - 30 MHZ TO 1 GHZ**



Test Mode	UNII-3_IEEE 802.11n (HT20)	Test Date	2020/5/5
Test Frequency	CH165: 5825 MHz	Polarization	Vertical

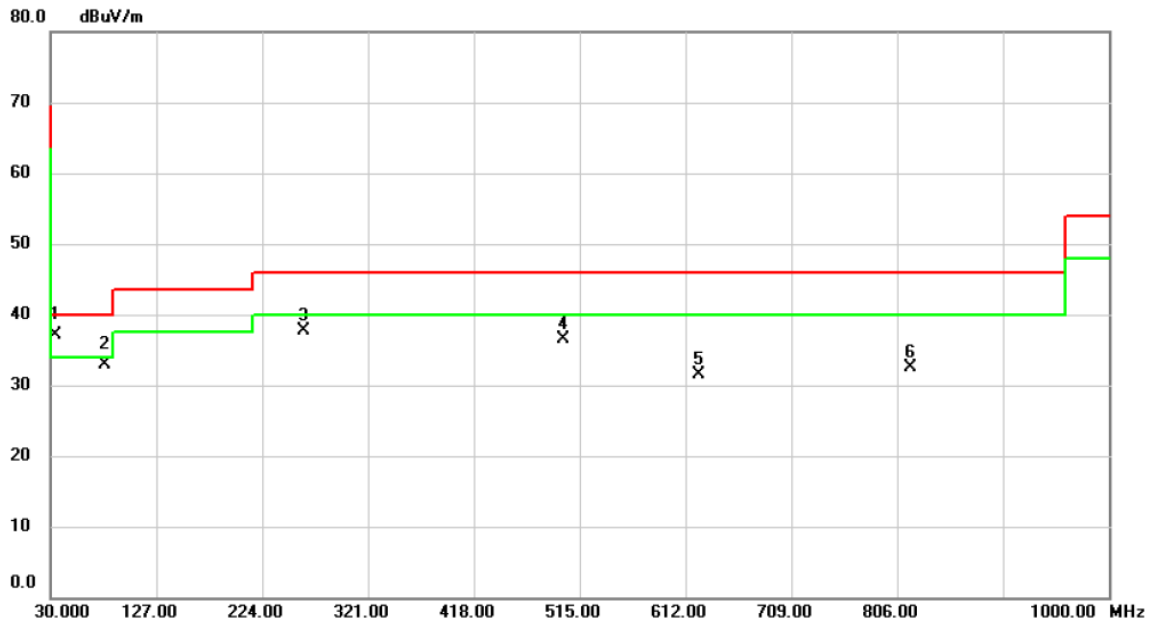

No.	Mk.	Freq.	Reading Level	Correct Factor	Measurement	Limit	Over	Detector	Comment
		MHz	dBuV	dB	dBuV/m	dBuV/m	dB		
1	*	34.8500	46.11	-9.01	37.10	40.00	-2.90	QP	
2		79.4700	45.24	-12.42	32.82	40.00	-7.18	QP	
3		261.8300	46.22	-8.58	37.64	46.00	-8.36	peak	
4		500.4500	39.41	-2.91	36.50	46.00	-9.50	peak	
5		624.6100	31.55	-0.11	31.44	46.00	-14.56	peak	
6		818.6100	29.14	3.40	32.54	46.00	-13.46	peak	

**REMARKS:**

- (1) Measurement Value = Reading Level + Correct Factor.
- (2) Margin Level = Measurement Value - Limit Value.

Test Mode	UNII-3_IEEE 802.11n (HT20)	Test Date	2020/5/5
Test Frequency	CH165: 5825 MHz	Polarization	Horizontal

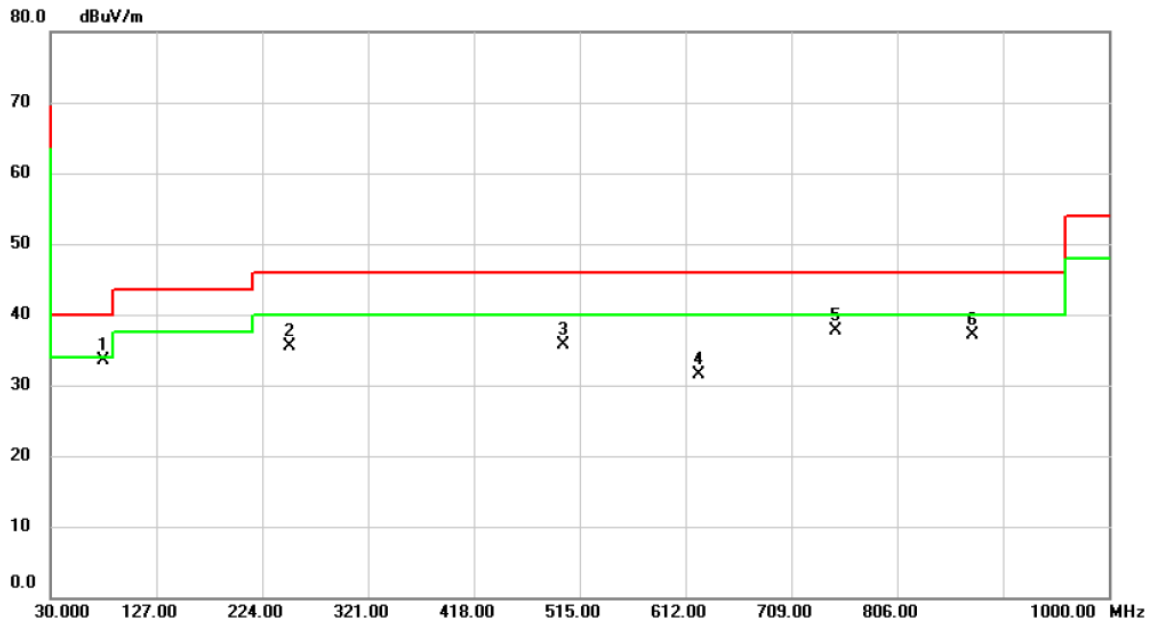

No.	Mk.	Freq.	Reading Level	Correct Factor	Measurement	Limit	Over	Detector	Comment
		MHz	dBuV	dB	dBuV/m	dBuV/m	dB		
1	*	78.5000	45.73	-12.25	33.48	40.00	-6.52	peak	
2		249.2200	44.62	-9.11	35.51	46.00	-10.49	peak	
3		500.4500	38.57	-2.91	35.66	46.00	-10.34	peak	
4		624.6100	31.58	-0.11	31.47	46.00	-14.53	peak	
5		749.7400	35.44	2.31	37.75	46.00	-8.25	peak	
6		874.8700	32.71	4.47	37.18	46.00	-8.82	peak	

**REMARKS:**

- (1) Measurement Value = Reading Level + Correct Factor.
- (2) Margin Level = Measurement Value - Limit Value.

## **APPENDIX B RADIATED EMISSIONS - ABOVE 1 GHZ**

Test Mode	UNII-1_IEEE 802.11a	Test Date	2020/4/29
Test Frequency	CH36: 5180 MHz	Polarization	Vertical

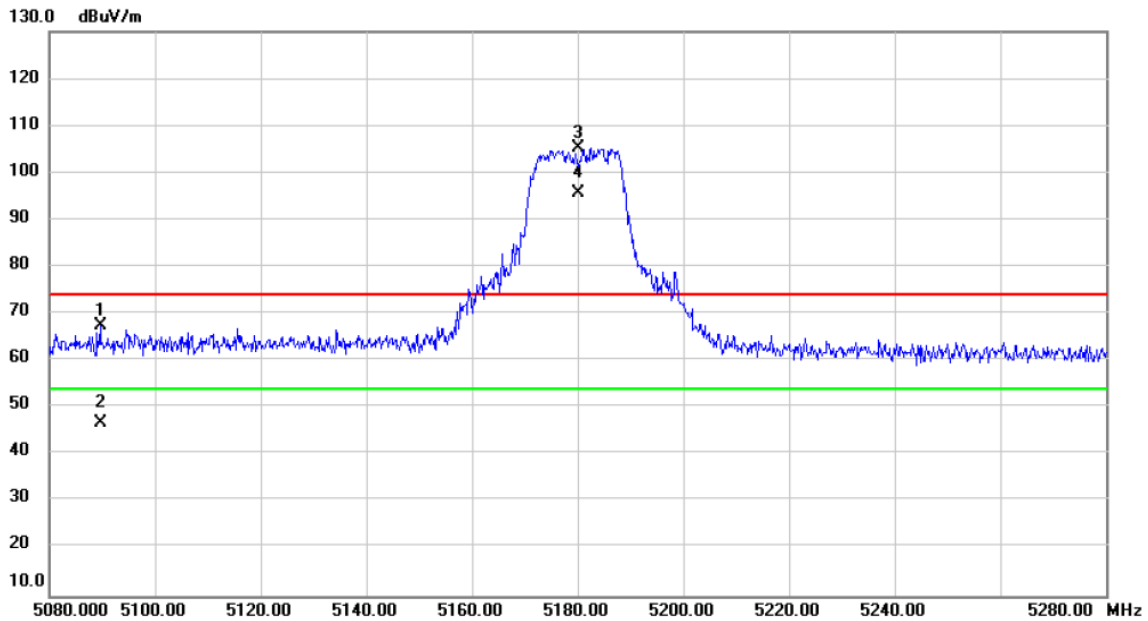

No.	Mk.	Freq.	Reading Level	Correct Factor	Measurement	Limit	Over	Detector	Comment
		MHz	dBuV	dB	dBuV/m	dBuV/m	dB		
1		5089.600	29.99	37.54	67.53	74.00	-6.47	peak	
2		5089.600	9.34	37.54	46.88	54.00	-7.12	AVG	
3	X	5180.000	67.48	37.65	105.13	74.00	31.13	peak	No Limit
4	*	5180.000	58.14	37.65	95.79	54.00	41.79	AVG	No Limit

**REMARKS:**

- (1) Measurement Value = Reading Level + Correct Factor.
- (2) Margin Level = Measurement Value - Limit Value.

Test Mode	UNII-1_IEEE 802.11a	Test Date	2020/4/29
Test Frequency	CH48: 5240 MHz	Polarization	Vertical

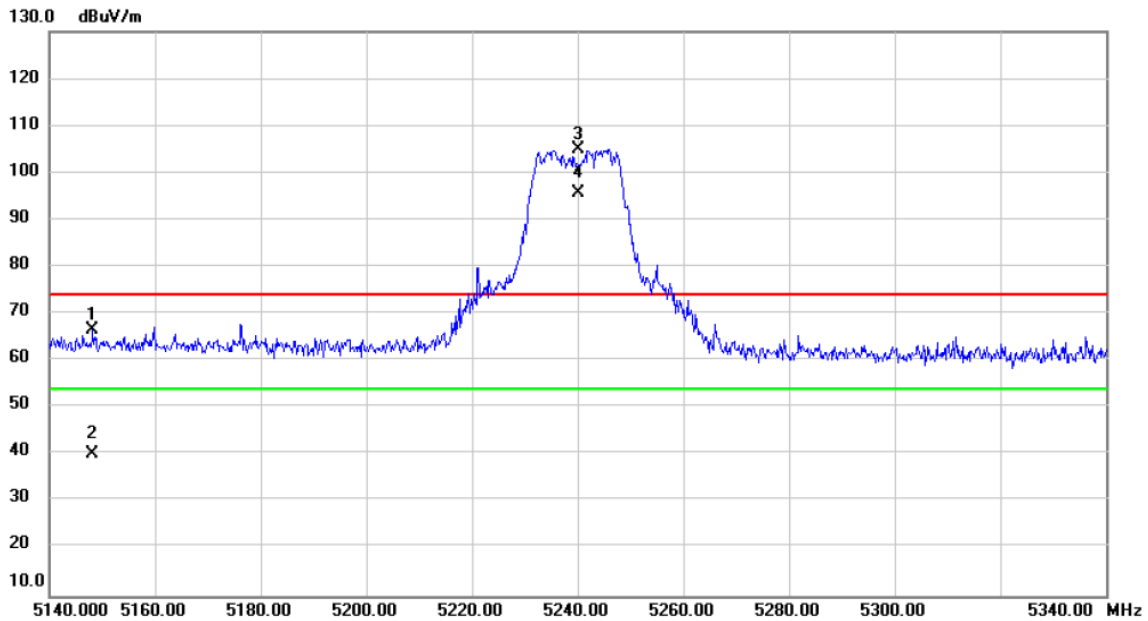

No.	Mk.	Freq.	Reading Level	Correct Factor	Measurement	Limit	Over	Detector	Comment
		MHz	dBuV	dB	dBuV/m	dBuV/m	dB		
1		5148.200	28.97	37.61	66.58	74.00	-7.42	peak	
2		5148.200	2.63	37.61	40.24	54.00	-13.76	AVG	
3	X	5240.000	67.21	37.71	104.92	74.00	30.92	peak	No Limit
4	*	5240.000	57.81	37.71	95.52	54.00	41.52	AVG	No Limit

**REMARKS:**

- (1) Measurement Value = Reading Level + Correct Factor.
- (2) Margin Level = Measurement Value - Limit Value.

Test Mode	UNII-3_IEEE 802.11a	Test Date	2020/4/29
Test Frequency	CH149: 5745 MHz	Polarization	Vertical

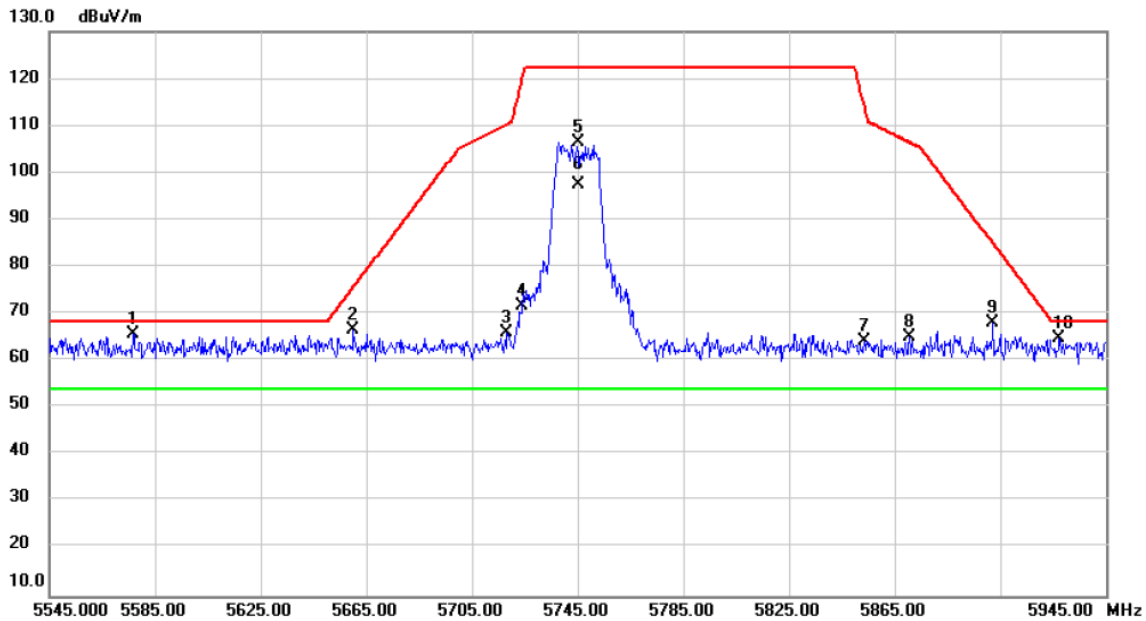

No. Mk.	Freq. MHz	Reading Level dBuV	Correct Factor dB	Measurement dBuV/m	Limit dBuV/m	Over dB	Detector	Comment
1	5576.600	27.53	38.12	65.65	68.20	-2.55	peak	
2	5660.200	28.31	38.23	66.54	75.77	-9.23	peak	
3	5718.200	27.50	38.32	65.82	110.30	-44.48	peak	
4	5724.200	33.38	38.32	71.70	120.38	-48.68	peak	
5	5745.000	68.06	38.35	106.41	122.20	-15.79	peak	No Limit
6 *	5745.000	59.08	38.35	97.43	54.00	43.43	AVG	No Limit
7	5853.400	25.73	38.50	64.23	114.45	-50.22	peak	
8	5870.600	26.45	38.53	64.98	106.43	-41.45	peak	
9	5902.200	29.47	38.57	68.04	85.03	-16.99	peak	
10	5927.400	26.26	38.61	64.87	68.20	-3.33	peak	

**REMARKS:**

- (1) Measurement Value = Reading Level + Correct Factor.
- (2) Margin Level = Measurement Value - Limit Value.

Test Mode	UNII-3_IEEE 802.11a	Test Date	2020/4/29
Test Frequency	CH165: 5825 MHz	Polarization	Vertical

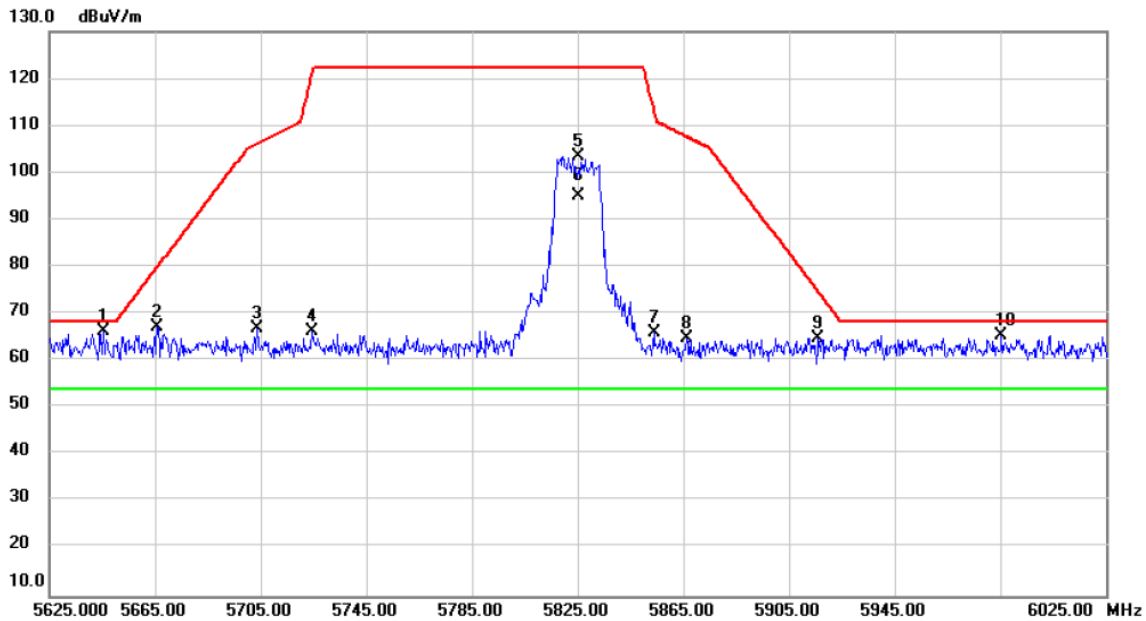

No.	Mk.	Freq. MHz	Reading Level dBuV	Correct Factor dB	Measure- ment dBuV/m	Limit dBuV/m	Over dB	Detector	Comment
1		5645.400	27.91	38.21	66.12	68.20	-2.08	peak	
2		5665.800	28.86	38.24	67.10	79.93	-12.83	peak	
3		5703.800	28.44	38.30	66.74	106.27	-39.53	peak	
4		5724.600	27.90	38.32	66.22	121.29	-55.07	peak	
5		5825.000	65.10	38.47	103.57	122.20	-18.63	peak	No Limit
6	*	5825.000	56.60	38.47	95.07	54.00	41.07	AVG	No Limit
7		5853.800	27.38	38.51	65.89	113.54	-47.65	peak	
8		5866.200	26.32	38.52	64.84	107.66	-42.82	peak	
9		5916.200	26.23	38.59	64.82	74.69	-9.87	peak	
10		5985.400	26.60	38.69	65.29	68.20	-2.91	peak	

**REMARKS:**

- (1) Measurement Value = Reading Level + Correct Factor.
- (2) Margin Level = Measurement Value - Limit Value.

Test Mode	UNII-1_IEEE 802.11n (HT20)	Test Date	2020/4/29
Test Frequency	CH36: 5180 MHz	Polarization	Vertical

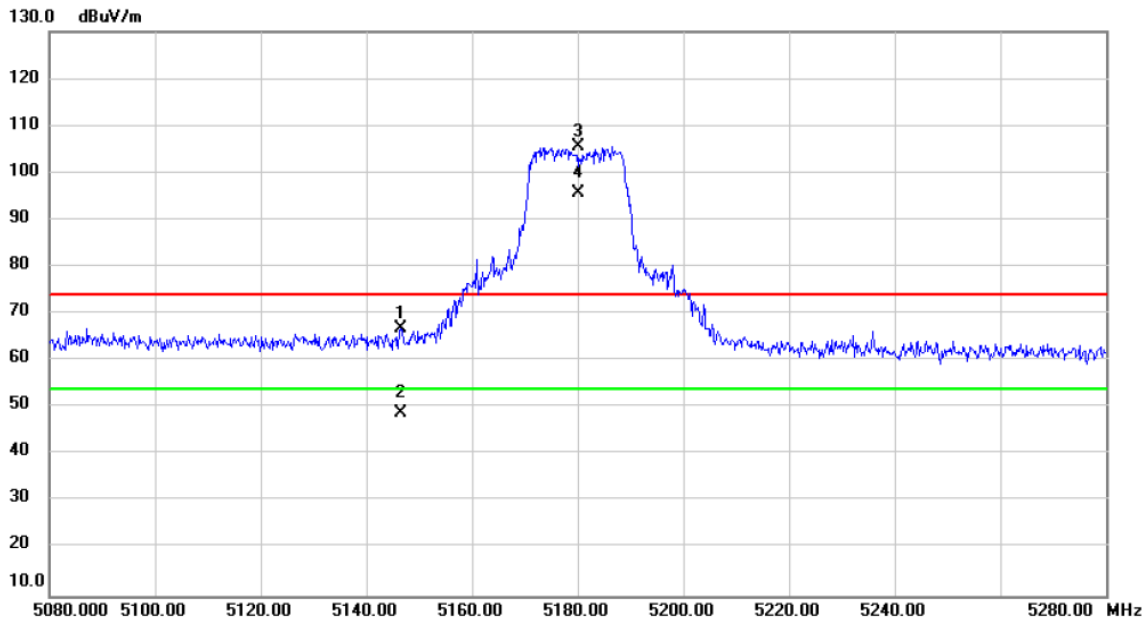

No.	Mk.	Freq.	Reading Level	Correct Factor	Measurement	Limit	Over	Detector	Comment
		MHz	dBuV	dB	dBuV/m	dBuV/m	dB		
1		5146.600	29.37	37.61	66.98	74.00	-7.02	peak	
2		5146.600	11.16	37.61	48.77	54.00	-5.23	AVG	
3	X	5180.000	67.81	37.65	105.46	74.00	31.46	peak	No Limit
4	*	5180.000	58.03	37.65	95.68	54.00	41.68	AVG	No Limit

**REMARKS:**

- (1) Measurement Value = Reading Level + Correct Factor.
- (2) Margin Level = Measurement Value - Limit Value.



Test Mode	UNII-1_IEEE 802.11n (HT20)	Test Date	2020/4/29
Test Frequency	CH48: 5240 MHz	Polarization	Vertical

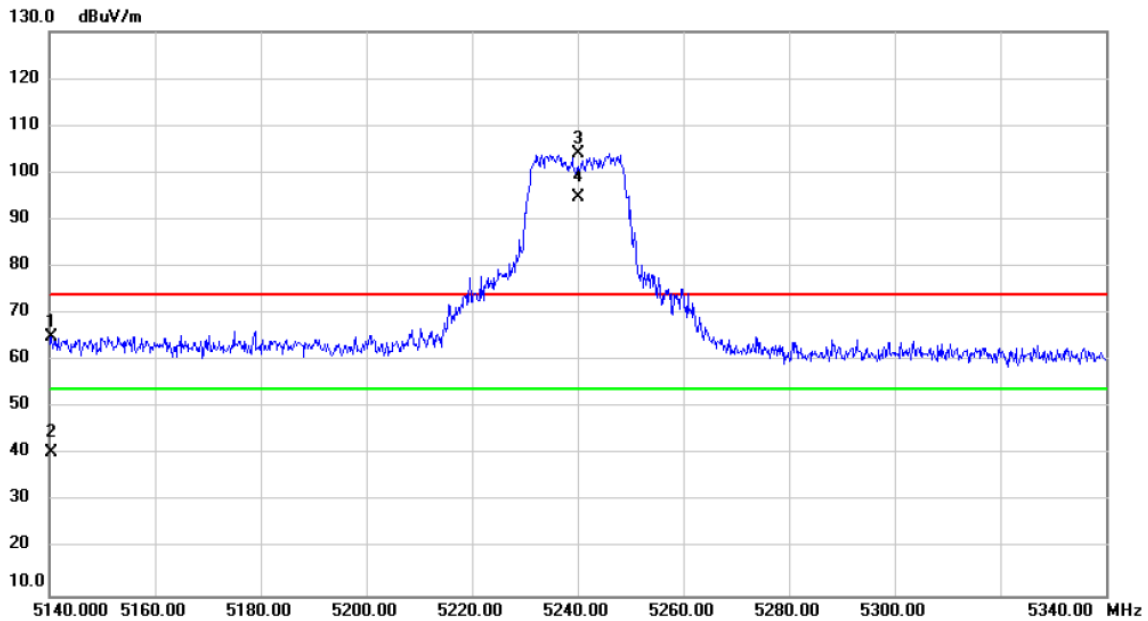

No.	Mk.	Freq.	Reading Level	Correct Factor	Measurement	Limit	Over	Detector	Comment
		MHz	dBuV	dB	dBuV/m	dBuV/m	dB		
1		5140.400	27.51	37.60	65.11	74.00	-8.89	peak	
2		5140.400	2.86	37.60	40.46	54.00	-13.54	AVG	
3	X	5240.000	66.46	37.71	104.17	74.00	30.17	peak	No Limit
4	*	5240.000	56.95	37.71	94.66	54.00	40.66	AVG	No Limit

**REMARKS:**

- (1) Measurement Value = Reading Level + Correct Factor.
- (2) Margin Level = Measurement Value - Limit Value.

Test Mode	UNII-3_IEEE 802.11n (HT20)	Test Date	2020/4/29
Test Frequency	CH149: 5745 MHz	Polarization	Vertical

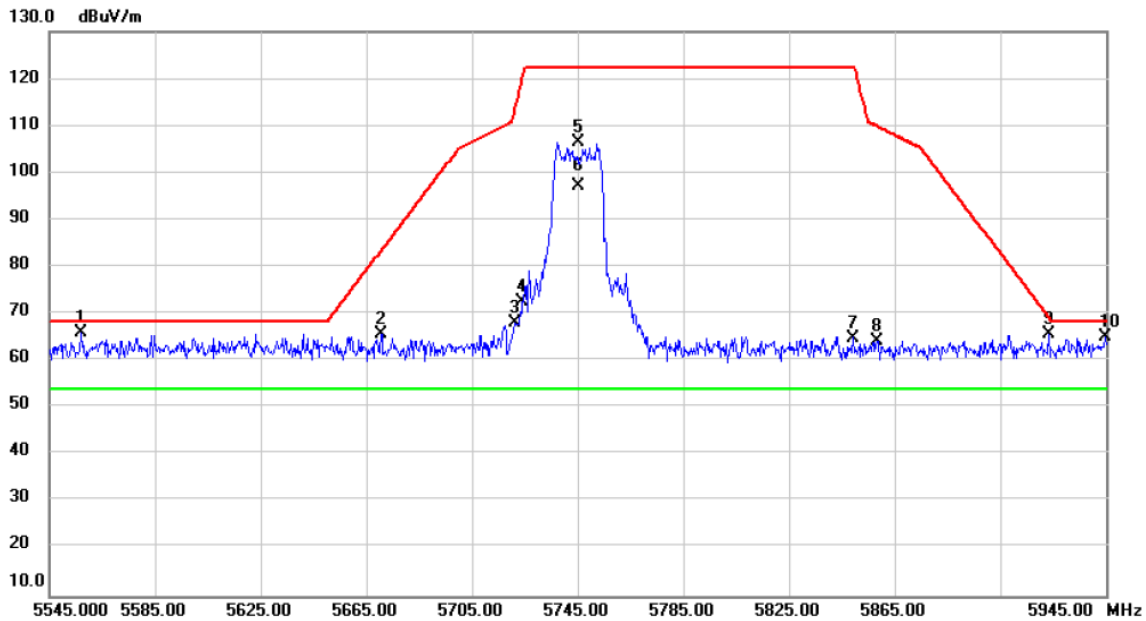

No.	Mk.	Freq.	Reading Level	Correct Factor	Measurement	Limit	Over	Detector	Comment
		MHz	dBuV	dB	dBuV/m	dBuV/m	dB		
1		5557.000	27.95	38.09	66.04	68.20	-2.16	peak	
2		5670.600	27.52	38.25	65.77	83.48	-17.71	peak	
3		5721.000	29.83	38.32	68.15	113.08	-44.93	peak	
4		5724.200	34.24	38.32	72.56	120.38	-47.82	peak	
5		5745.000	68.00	38.35	106.35	122.20	-15.85	peak	No Limit
6	*	5745.000	58.74	38.35	97.09	54.00	43.09	AVG	No Limit
7		5849.400	26.24	38.50	64.74	122.20	-57.46	peak	
8		5858.200	25.66	38.51	64.17	109.90	-45.73	peak	
9		5923.400	27.16	38.60	65.76	69.38	-3.62	peak	
10		5944.600	26.36	38.63	64.99	68.20	-3.21	peak	

**REMARKS:**

- (1) Measurement Value = Reading Level + Correct Factor.
- (2) Margin Level = Measurement Value - Limit Value.

Test Mode	UNII-3_IEEE 802.11n (HT20)	Test Date	2020/4/29
Test Frequency	CH165: 5825 MHz	Polarization	Vertical

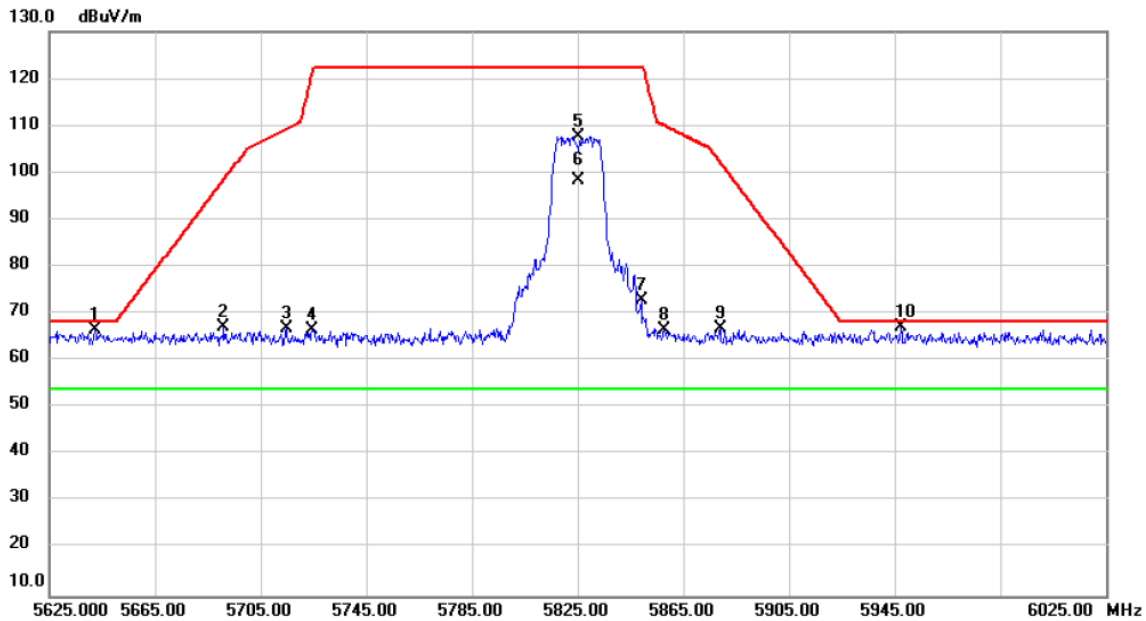

No. Mk.	Freq. MHz	Reading Level dBuV	Correct Factor dB	Measurement dBuV/m	Limit dBuV/m	Over dB	Detector	Comment
1	5642.200	28.24	38.21	66.45	68.20	-1.75	peak	
2	5691.000	28.87	38.28	67.15	98.56	-31.41	peak	
3	5714.600	28.59	38.31	66.90	109.29	-42.39	peak	
4	5724.600	28.35	38.32	66.67	121.29	-54.62	peak	
5	5825.000	69.31	38.47	107.78	122.20	-14.42	peak	No Limit
6 *	5825.000	59.97	38.47	98.44	54.00	44.44	AVG	No Limit
7	5849.000	34.31	38.50	72.81	122.20	-49.39	peak	
8	5857.800	28.00	38.51	66.51	110.01	-43.50	peak	
9	5879.000	28.37	38.54	66.91	102.23	-35.32	peak	
10	5947.400	28.54	38.64	67.18	68.20	-1.02	peak	

**REMARKS:**

- (1) Measurement Value = Reading Level + Correct Factor.
- (2) Margin Level = Measurement Value - Limit Value.

Test Mode	UNII-1_IEEE 802.11n (HT40)	Test Date	2020/4/29
Test Frequency	CH38: 5190 MHz	Polarization	Vertical

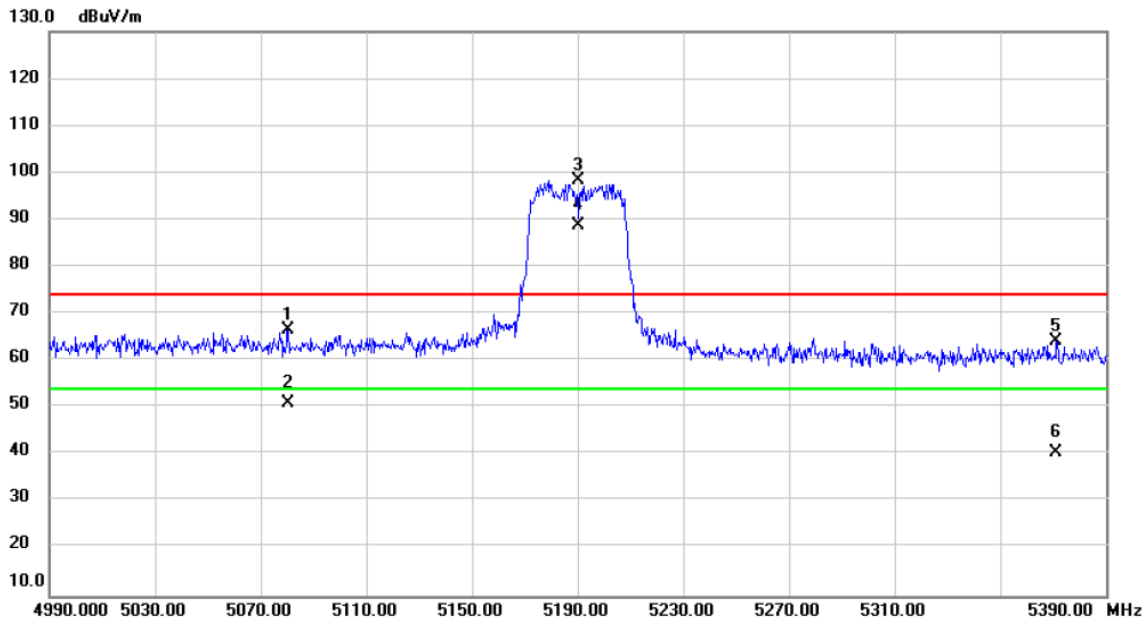

No.	Mk.	Freq.	Reading Level	Correct Factor	Measurement	Limit	Over	Detector	Comment
		MHz	dBuV	dB	dBuV/m	dBuV/m	dB		
1		5080.400	29.14	37.53	66.67	74.00	-7.33	peak	
2		5080.400	13.29	37.53	50.82	54.00	-3.18	AVG	
3	X	5190.000	60.75	37.65	98.40	74.00	24.40	peak	No Limit
4	*	5190.000	51.12	37.65	88.77	54.00	34.77	AVG	No Limit
5		5371.200	26.27	37.86	64.13	74.00	-9.87	peak	
6		5371.200	2.64	37.86	40.50	54.00	-13.50	AVG	

**REMARKS:**

- (1) Measurement Value = Reading Level + Correct Factor.
- (2) Margin Level = Measurement Value - Limit Value.

Test Mode	UNII-1_IEEE 802.11n (HT40)	Test Date	2020/4/29
Test Frequency	CH46: 5230 MHz	Polarization	Vertical

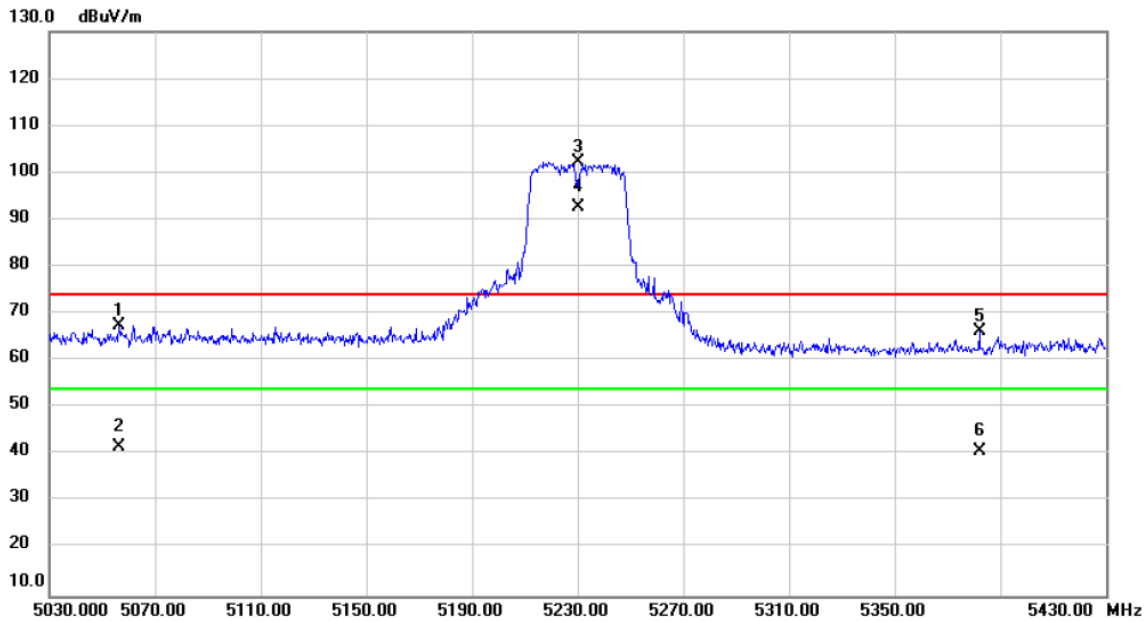

No.	Mk.	Freq. MHz	Reading Level dBuV	Correct Factor dB	Measure- ment dBuV/m	Limit dBuV/m	Over dB	Detector	Comment
1		5056.400	30.01	37.50	67.51	74.00	-6.49	peak	
2		5056.400	4.09	37.50	41.59	54.00	-12.41	AVG	
3	X	5230.000	64.59	37.70	102.29	74.00	28.29	peak	No Limit
4	*	5230.000	54.87	37.70	92.57	54.00	38.57	AVG	No Limit
5		5382.000	28.34	37.88	66.22	74.00	-7.78	peak	
6		5382.000	2.86	37.88	40.74	54.00	-13.26	AVG	

**REMARKS:**

- (1) Measurement Value = Reading Level + Correct Factor.
- (2) Margin Level = Measurement Value - Limit Value.

Test Mode	UNII-3_ IEEE 802.11n (HT40)	Test Date	2020/4/29
Test Frequency	CH151: 5755 MHz	Polarization	Vertical

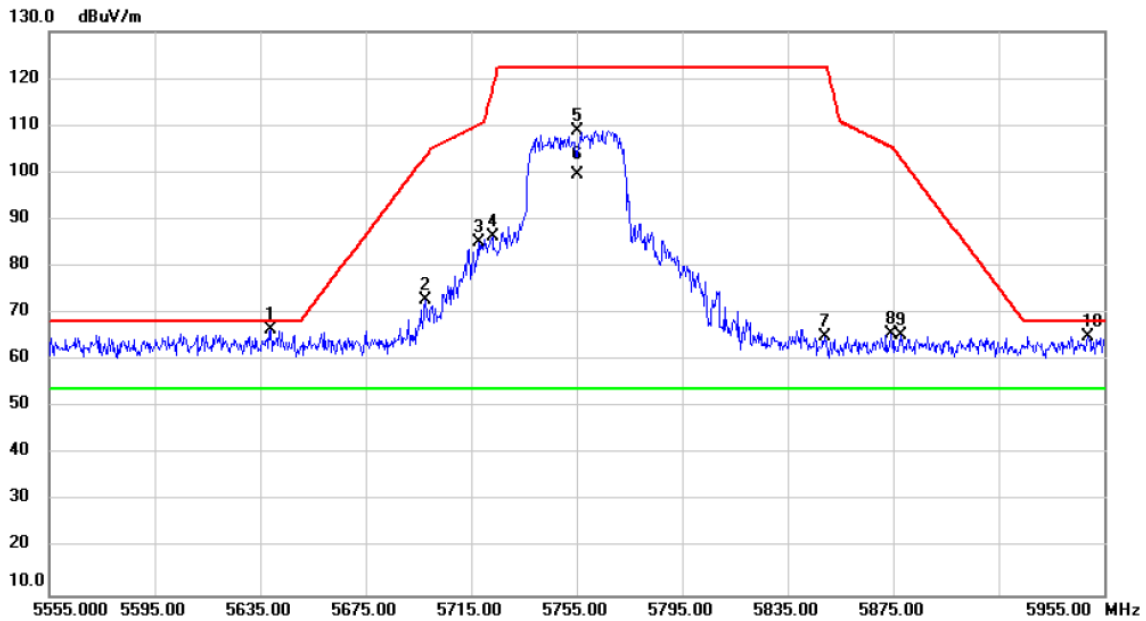

No.	Mk.	Freq. MHz	Reading Level dBuV	Correct Factor dB	Measure- ment dBuV/m	Limit dBuV/m	Over dB	Detector	Comment
1		5639.000	28.31	38.20	66.51	68.20	-1.69	peak	
2		5697.800	34.61	38.29	72.90	103.58	-30.68	peak	
3		5717.800	46.88	38.31	85.19	110.18	-24.99	peak	
4		5723.000	47.90	38.32	86.22	117.64	-31.42	peak	
5		5755.000	70.59	38.37	108.96	122.20	-13.24	peak	No Limit
6	*	5755.000	61.22	38.37	99.59	54.00	45.59	AVG	No Limit
7		5849.000	26.60	38.50	65.10	122.20	-57.10	peak	
8		5874.200	27.21	38.53	65.74	105.42	-39.68	peak	
9		5877.800	26.84	38.54	65.38	103.12	-37.74	peak	
10		5949.000	26.51	38.64	65.15	68.20	-3.05	peak	

**REMARKS:**

- (1) Measurement Value = Reading Level + Correct Factor.
- (2) Margin Level = Measurement Value - Limit Value.

Test Mode	UNII-3_IEEE 802.11n (HT40)	Test Date	2020/4/29
Test Frequency	CH159: 5795 MHz	Polarization	Vertical

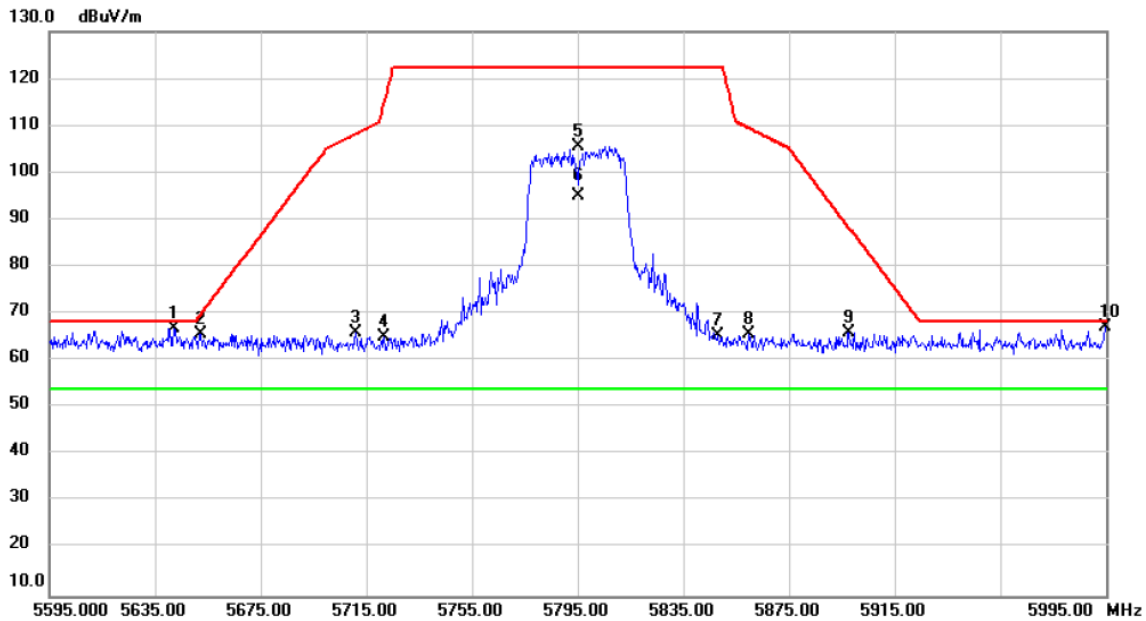

No.	Mk.	Freq.	Reading Level	Correct Factor	Measurement	Limit	Over	Detector	Comment
		MHz	dBuV	dB	dBuV/m	dBuV/m	dB		
1		5642.200	28.75	38.21	66.96	68.20	-1.24	peak	
2		5652.200	27.51	38.22	65.73	69.83	-4.10	peak	
3		5711.000	27.61	38.31	65.92	108.28	-42.36	peak	
4		5721.800	26.77	38.32	65.09	114.91	-49.82	peak	
5		5795.000	67.25	38.42	105.67	122.20	-16.53	peak	No Limit
6	*	5795.000	56.56	38.42	94.98	54.00	40.98	AVG	No Limit
7		5848.200	26.81	38.50	65.31	122.20	-56.89	peak	
8		5859.800	27.11	38.51	65.62	109.45	-43.83	peak	
9		5897.800	27.34	38.57	65.91	88.29	-22.38	peak	
10		5994.600	28.33	38.70	67.03	68.20	-1.17	peak	

**REMARKS:**

- (1) Measurement Value = Reading Level + Correct Factor.
- (2) Margin Level = Measurement Value - Limit Value.

Test Mode	UNII-1_IEEE 802.11ac (VHT80)	Test Date	2020/4/29
Test Frequency	CH42: 5210 MHz	Polarization	Vertical

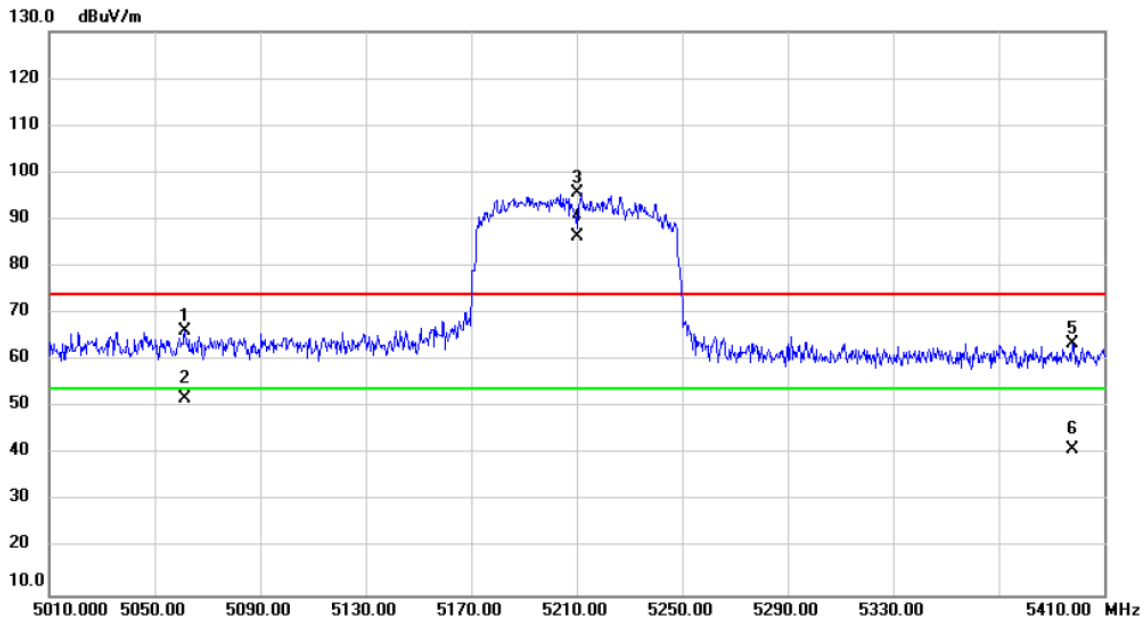

No.	Mk.	Freq.	Reading Level	Correct Factor	Measurement	Limit	Over	Detector	Comment
		MHz	dBuV	dB	dBuV/m	dBuV/m	dB		
1		5061.600	28.77	37.51	66.28	74.00	-7.72	peak	
2		5061.600	14.34	37.51	51.85	54.00	-2.15	AVG	
3	X	5210.000	57.91	37.68	95.59	74.00	21.59	peak	No Limit
4	*	5210.000	48.69	37.68	86.37	54.00	32.37	AVG	No Limit
5		5398.000	25.75	37.89	63.64	74.00	-10.36	peak	
6		5398.000	3.28	37.89	41.17	54.00	-12.83	AVG	

**REMARKS:**

- (1) Measurement Value = Reading Level + Correct Factor.
- (2) Margin Level = Measurement Value - Limit Value.



Test Mode	UNII-3_ IEEE 802.11ac (VHT80)	Test Date	2020/4/29
Test Frequency	CH155: 5775 MHz	Polarization	Vertical

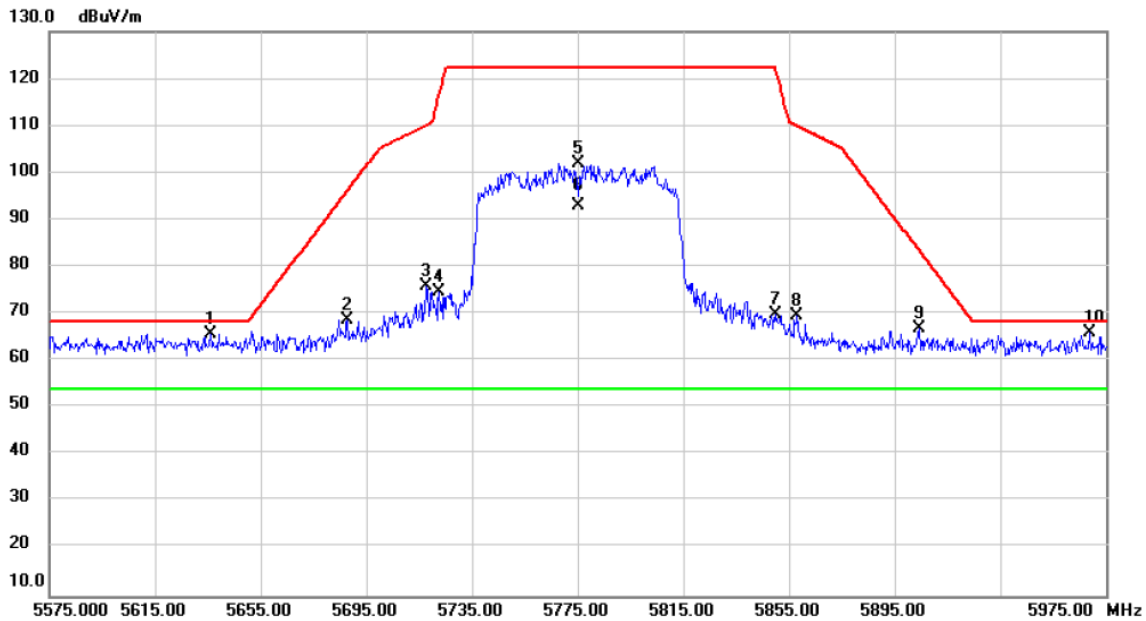

No.	Mk.	Freq.	Reading Level	Correct Factor	Measurement	Limit	Over	Detector	Comment
		MHz	dBuV	dB	dBuV/m	dBuV/m	dB		
1		5636.200	27.58	38.20	65.78	68.20	-2.42	peak	
2		5687.800	30.50	38.27	68.77	96.20	-27.43	peak	
3		5717.800	37.50	38.31	75.81	110.18	-34.37	peak	
4		5722.600	36.40	38.32	74.72	116.73	-42.01	peak	
5		5775.000	63.52	38.39	101.91	122.20	-20.29	peak	No Limit
6	*	5775.000	54.46	38.39	92.85	54.00	38.85	AVG	No Limit
7		5850.200	31.27	38.50	69.77	121.74	-51.97	peak	
8		5858.200	30.89	38.51	69.40	109.90	-40.50	peak	
9		5904.200	28.27	38.58	66.85	83.55	-16.70	peak	
10		5968.600	27.25	38.67	65.92	68.20	-2.28	peak	

**REMARKS:**

- (1) Measurement Value = Reading Level + Correct Factor.
- (2) Margin Level = Measurement Value - Limit Value.

Test Mode	UNII-1_IEEE 802.11a	Test Date	2020/5/4
Test Frequency	CH36: 5180 MHz	Polarization	Vertical

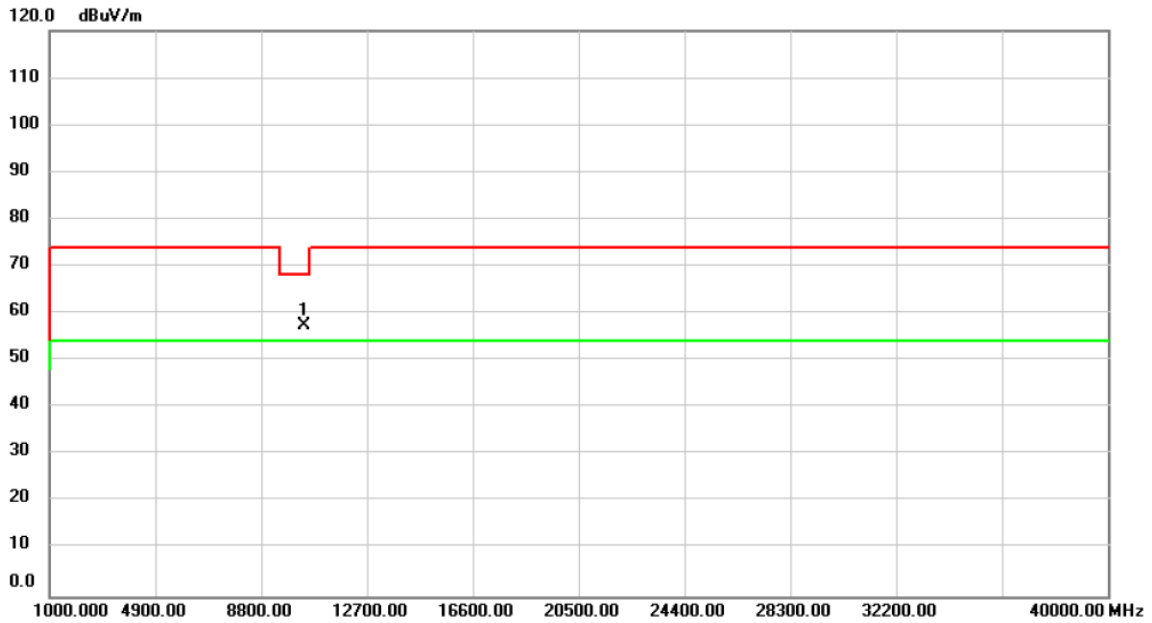

No.	Mk.	Freq.	Reading Level	Correct Factor	Measurement	Limit	Over	Detector	Comment
		MHz	dBuV	dB	dBuV/m	dBuV/m	dB		
1	*	10360.00	53.85	3.68	57.53	68.20	-10.67	peak	

**REMARKS:**

- (1) Measurement Value = Reading Level + Correct Factor.
- (2) Margin Level = Measurement Value - Limit Value.

Test Mode	UNII-1_IEEE 802.11a	Test Date	2020/5/4
Test Frequency	CH36: 5180 MHz	Polarization	Horizontal

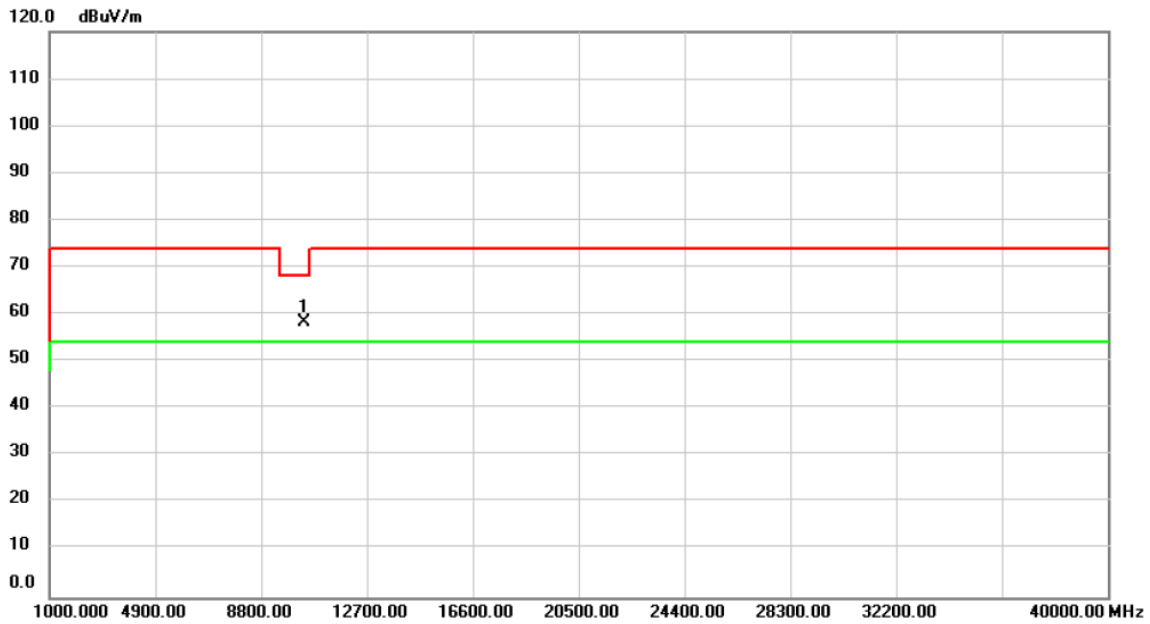

No.	Mk.	Freq.	Reading Level	Correct Factor	Measurement	Limit	Over	Detector	Comment
		MHz	dBuV	dB	dBuV/m	dBuV/m	dB		
1	*	10360.00	54.55	3.68	58.23	68.20	-9.97	peak	

**REMARKS:**

- (1) Measurement Value = Reading Level + Correct Factor.
- (2) Margin Level = Measurement Value - Limit Value.

Test Mode	UNII-1_IEEE 802.11a	Test Date	2020/5/4
Test Frequency	CH40: 5200 MHz	Polarization	Vertical

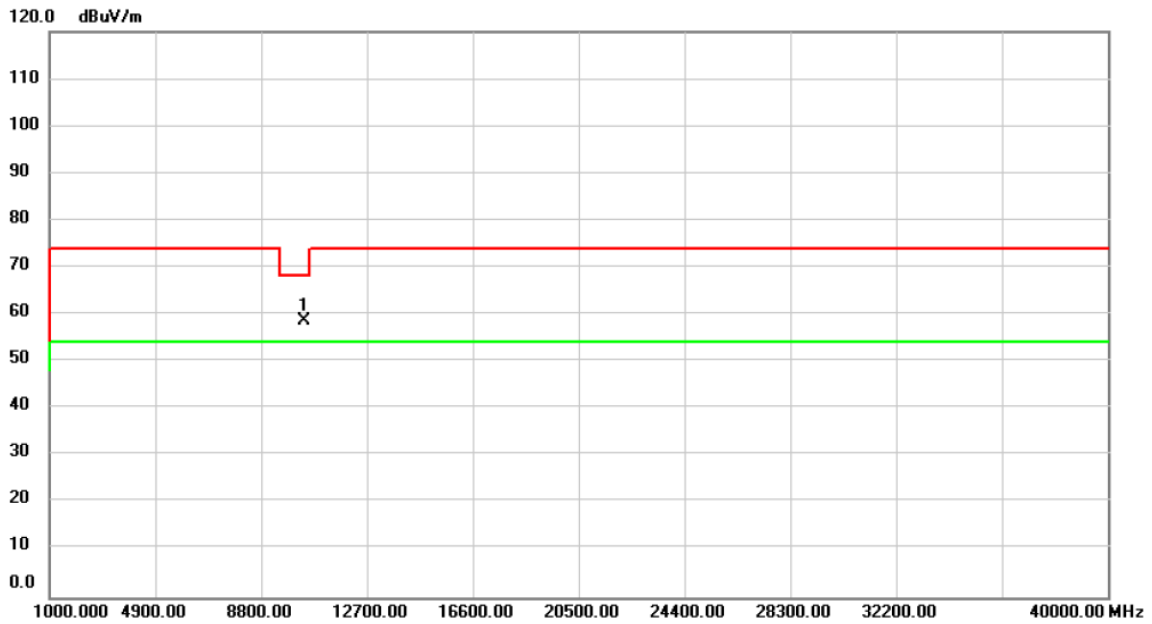

No.	Mk.	Freq.	Reading Level	Correct Factor	Measurement	Limit	Over	Detector	Comment
		MHz	dBuV	dB	dBuV/m	dBuV/m	dB		
1	*	10400.00	54.80	3.74	58.54	68.20	-9.66	peak	

**REMARKS:**

- (1) Measurement Value = Reading Level + Correct Factor.
- (2) Margin Level = Measurement Value - Limit Value.

Test Mode	UNII-1_IEEE 802.11a	Test Date	2020/5/4
Test Frequency	CH40: 5200 MHz	Polarization	Horizontal

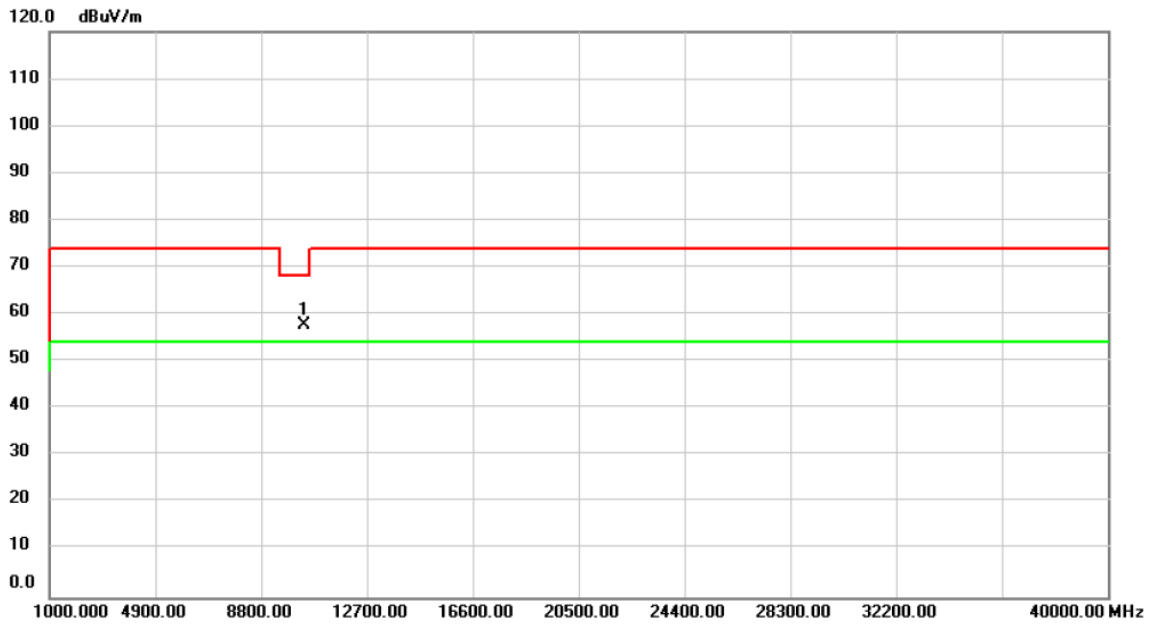

No.	Mk.	Freq.	Reading Level	Correct Factor	Measurement	Limit	Over	Detector	Comment
		MHz	dBuV	dB	dBuV/m	dBuV/m	dB		
1	*	10400.00	54.00	3.74	57.74	68.20	-10.46	peak	

**REMARKS:**

- (1) Measurement Value = Reading Level + Correct Factor.
- (2) Margin Level = Measurement Value - Limit Value.

Test Mode	UNII-1_IEEE 802.11a	Test Date	2020/5/4
Test Frequency	CH48: 5240 MHz	Polarization	Vertical

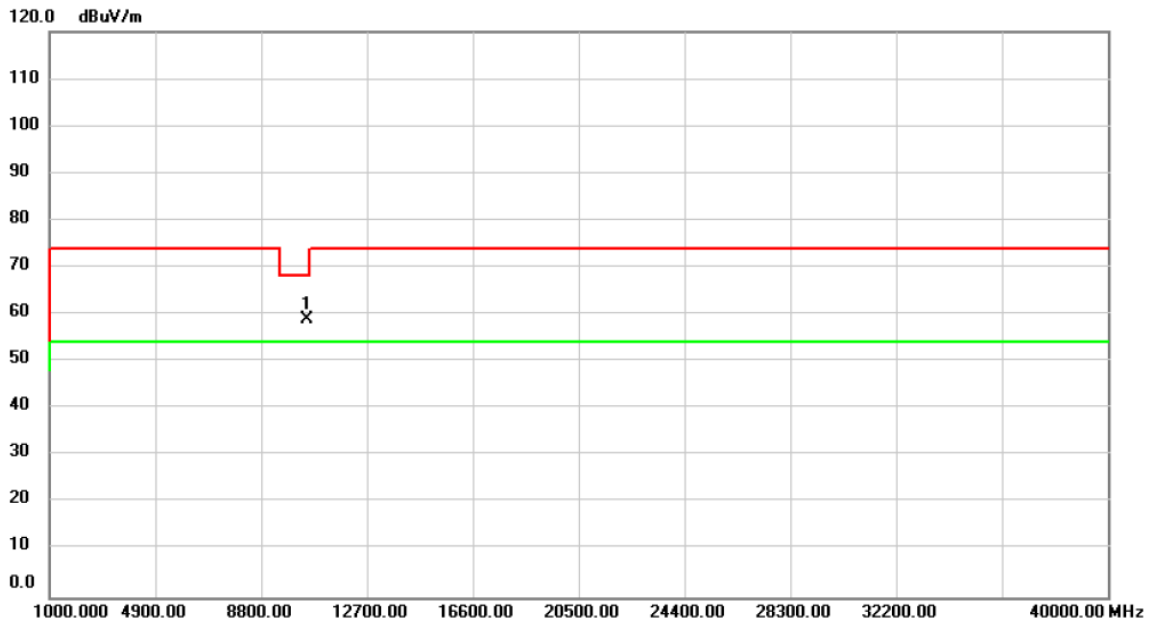

No.	Mk.	Freq.	Reading Level	Correct Factor	Measurement	Limit	Over	Detector	Comment
		MHz	dBuV	dB	dBuV/m	dBuV/m	dB		
1	*	10480.00	55.04	3.84	58.88	68.20	-9.32	peak	

**REMARKS:**

- (1) Measurement Value = Reading Level + Correct Factor.
- (2) Margin Level = Measurement Value - Limit Value.

Test Mode	UNII-1_IEEE 802.11a	Test Date	2020/5/4
Test Frequency	CH48: 5240 MHz	Polarization	Horizontal

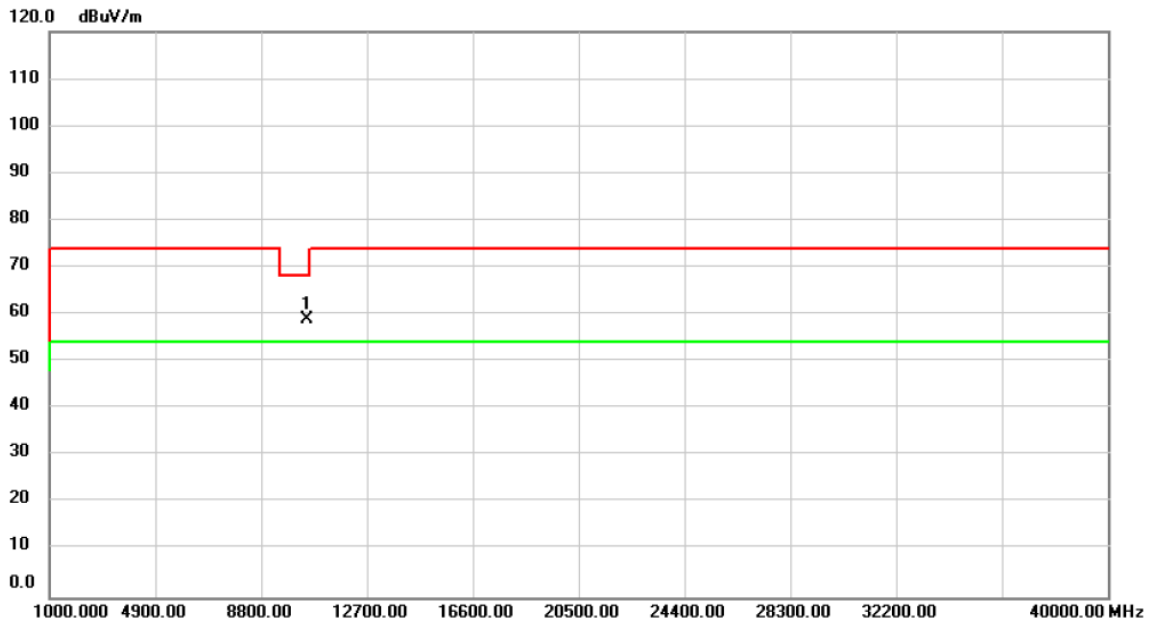

No.	Mk.	Freq.	Reading Level	Correct Factor	Measurement	Limit	Over	Detector	Comment
		MHz	dBuV	dB	dBuV/m	dBuV/m	dB		
1	*	10480.00	55.17	3.84	59.01	68.20	-9.19	peak	

**REMARKS:**

- (1) Measurement Value = Reading Level + Correct Factor.
- (2) Margin Level = Measurement Value - Limit Value.

Test Mode	UNII-3_IEEE 802.11a	Test Date	2020/5/4
Test Frequency	CH149: 5745 MHz	Polarization	Vertical

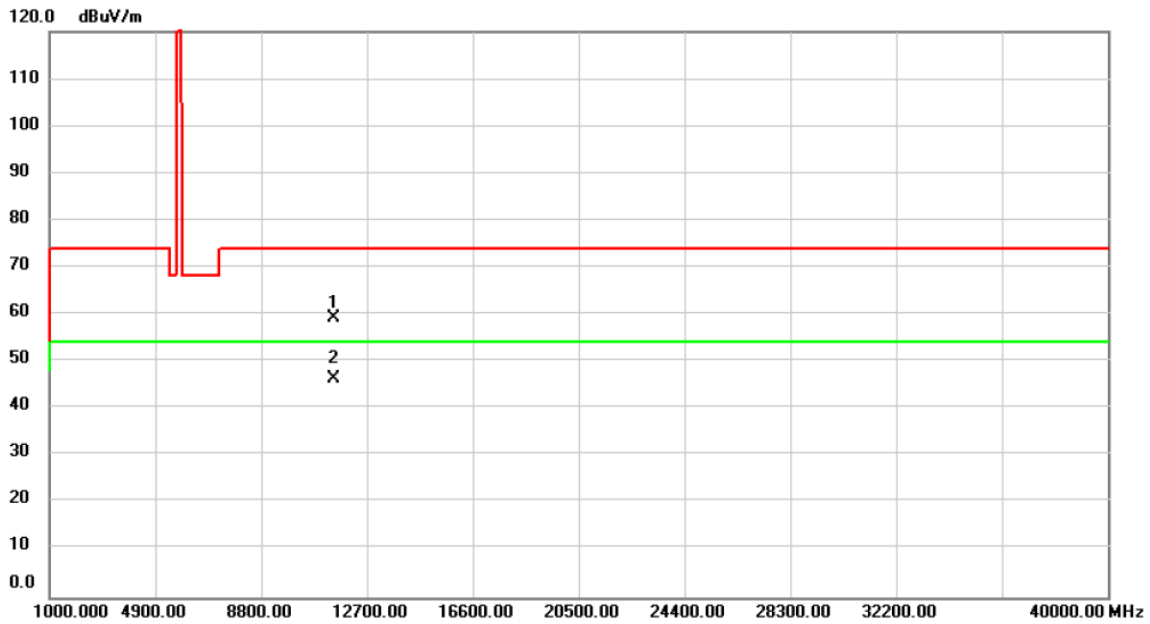

No.	Mk.	Freq.	Reading Level	Correct Factor	Measurement	Limit	Over	Detector	Comment
		MHz	dBuV	dB	dBuV/m	dBuV/m	dB		
1		11490.00	54.13	5.11	59.24	74.00	-14.76	peak	
2	*	11490.00	41.27	5.11	46.38	54.00	-7.62	AVG	

**REMARKS:**

- (1) Measurement Value = Reading Level + Correct Factor.
- (2) Margin Level = Measurement Value - Limit Value.



Test Mode	UNII-3_IEEE 802.11a	Test Date	2020/5/4
Test Frequency	CH149: 5745 MHz	Polarization	Horizontal

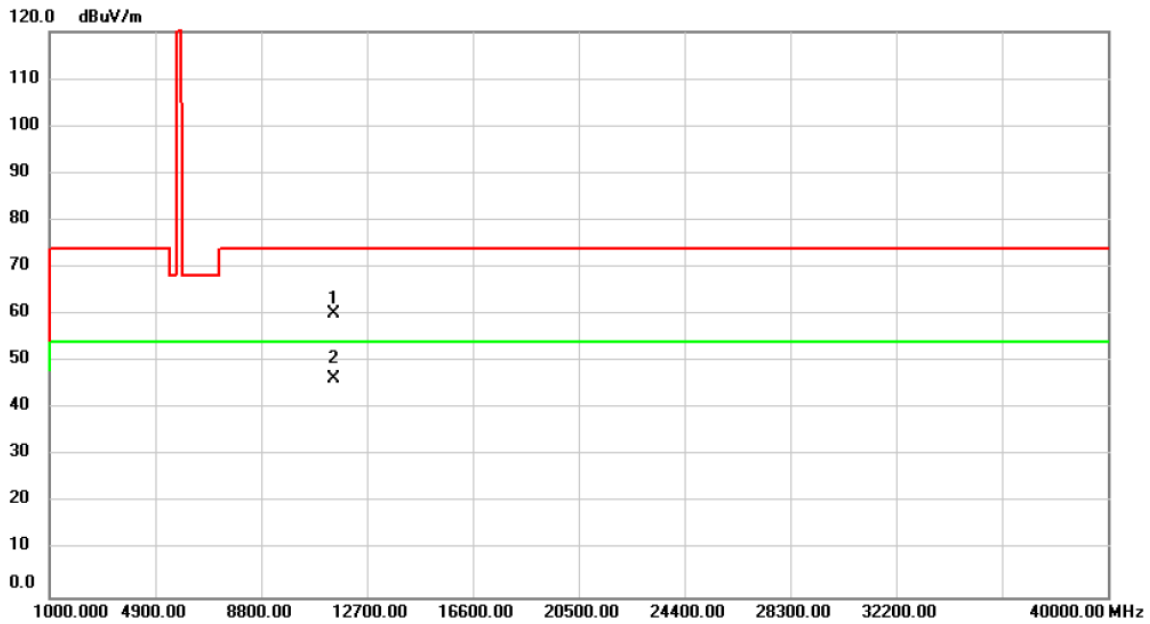

No.	Mk.	Freq.	Reading Level	Correct Factor	Measurement	Limit	Over	Detector	Comment
		MHz	dBuV	dB	dBuV/m	dBuV/m	dB		
1		11490.00	55.02	5.11	60.13	74.00	-13.87	peak	
2	*	11490.00	41.30	5.11	46.41	54.00	-7.59	AVG	

**REMARKS:**

- (1) Measurement Value = Reading Level + Correct Factor.
- (2) Margin Level = Measurement Value - Limit Value.

Test Mode	UNII-3_IEEE 802.11a	Test Date	2020/5/4
Test Frequency	CH157: 5785 MHz	Polarization	Vertical

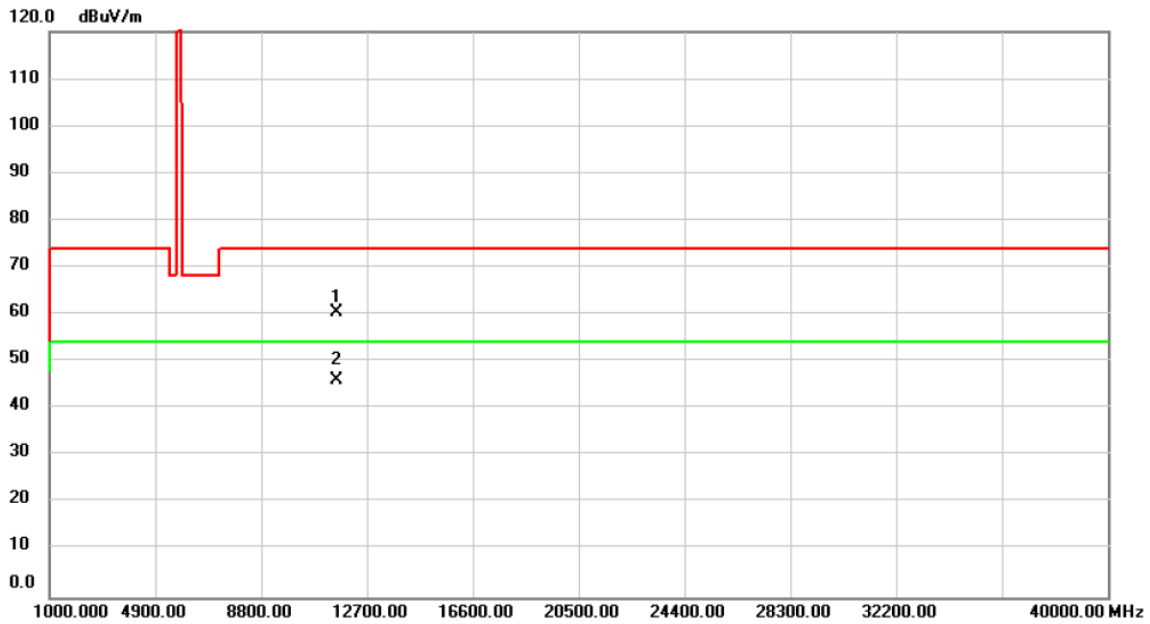

No.	Mk.	Freq.	Reading Level	Correct Factor	Measurement	Limit	Over	Detector	Comment
		MHz	dBuV	dB	dBuV/m	dBuV/m	dB		
1		11570.00	55.60	4.78	60.38	74.00	-13.62	peak	
2	*	11570.00	41.35	4.78	46.13	54.00	-7.87	AVG	

**REMARKS:**

- (1) Measurement Value = Reading Level + Correct Factor.
- (2) Margin Level = Measurement Value - Limit Value.

Test Mode	UNII-3_IEEE 802.11a	Test Date	2020/5/4
Test Frequency	CH157: 5785 MHz	Polarization	Horizontal

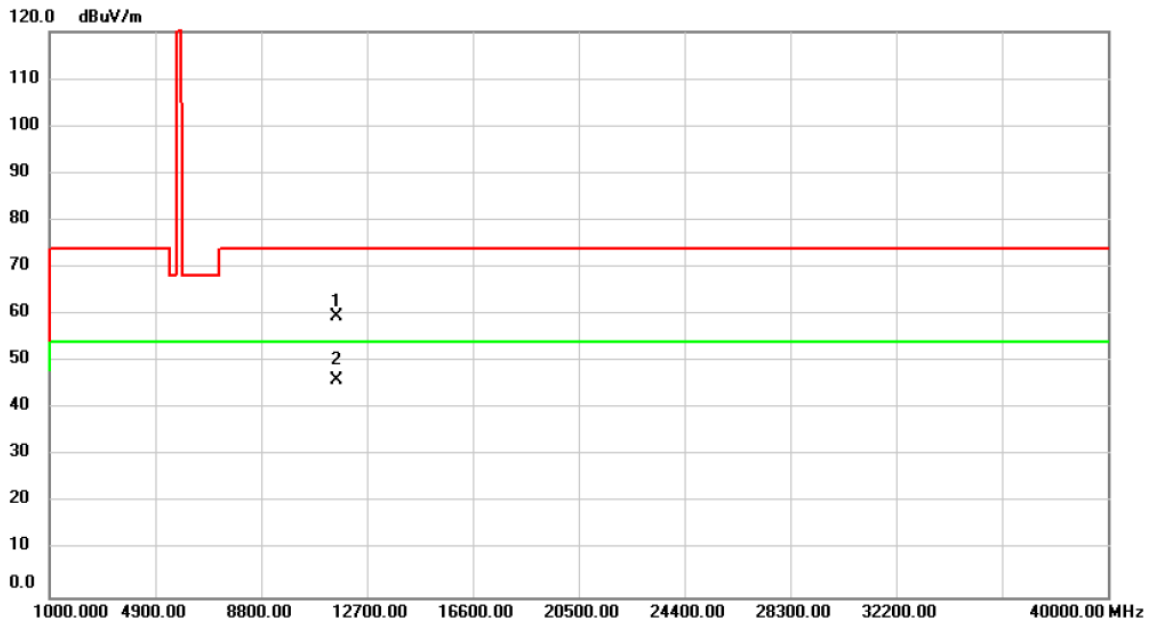

No.	Mk.	Freq.	Reading Level	Correct Factor	Measurement	Limit	Over	Detector	Comment
		MHz	dBuV	dB	dBuV/m	dBuV/m	dB		
1		11570.00	54.86	4.78	59.64	74.00	-14.36	peak	
2	*	11570.00	41.26	4.78	46.04	54.00	-7.96	AVG	

**REMARKS:**

- (1) Measurement Value = Reading Level + Correct Factor.
- (2) Margin Level = Measurement Value - Limit Value.

Test Mode	UNII-3_IEEE 802.11a	Test Date	2020/5/4
Test Frequency	CH165: 5825 MHz	Polarization	Vertical

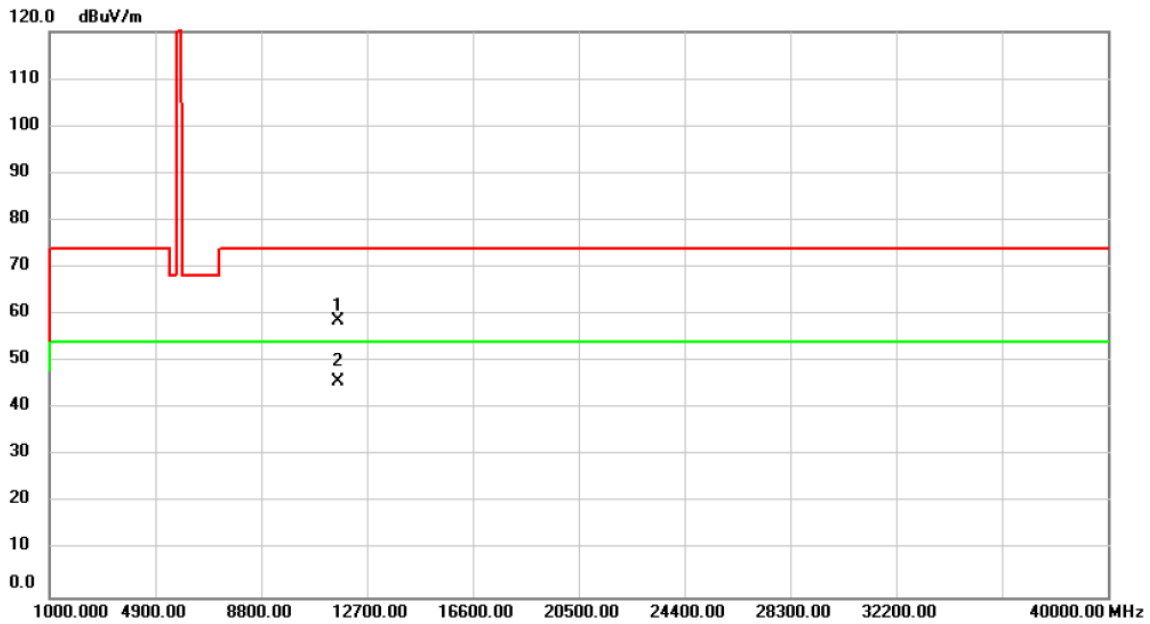

No.	Mk.	Freq.	Reading Level	Correct Factor	Measurement	Limit	Over	Detector	Comment
		MHz	dBuV	dB	dBuV/m	dBuV/m	dB		
1		11650.00	54.12	4.40	58.52	74.00	-15.48	peak	
2	*	11650.00	41.38	4.40	45.78	54.00	-8.22	AVG	

**REMARKS:**

- (1) Measurement Value = Reading Level + Correct Factor.
- (2) Margin Level = Measurement Value - Limit Value.

Test Mode	UNII-3_IEEE 802.11a	Test Date	2020/5/4
Test Frequency	CH165: 5825 MHz	Polarization	Horizontal

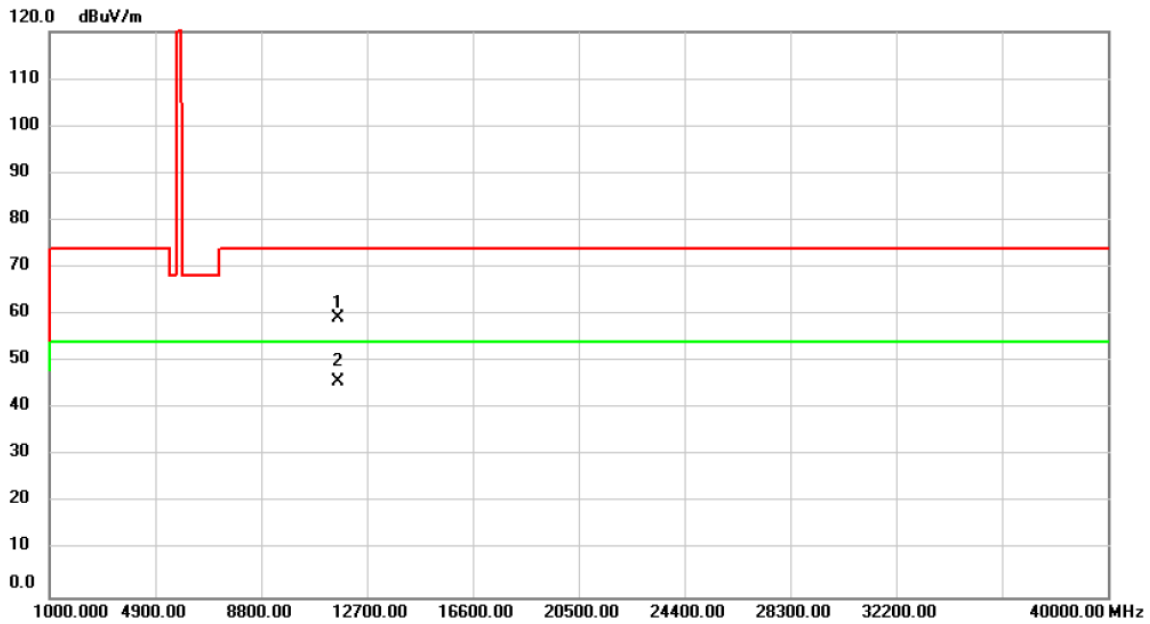

No.	Mk.	Freq. MHz	Reading Level dBuV	Correct Factor dB	Measure- ment dBuV/m	Limit dBuV/m	Over dB	Detector	Comment
1		11650.00	54.78	4.40	59.18	74.00	-14.82	peak	
2	*	11650.00	41.45	4.40	45.85	54.00	-8.15	AVG	

**REMARKS:**

- (1) Measurement Value = Reading Level + Correct Factor.
- (2) Margin Level = Measurement Value - Limit Value.

Test Mode	UNII-1_IEEE 802.11n (HT20)	Test Date	2020/5/4
Test Frequency	CH36: 5180 MHz	Polarization	Vertical

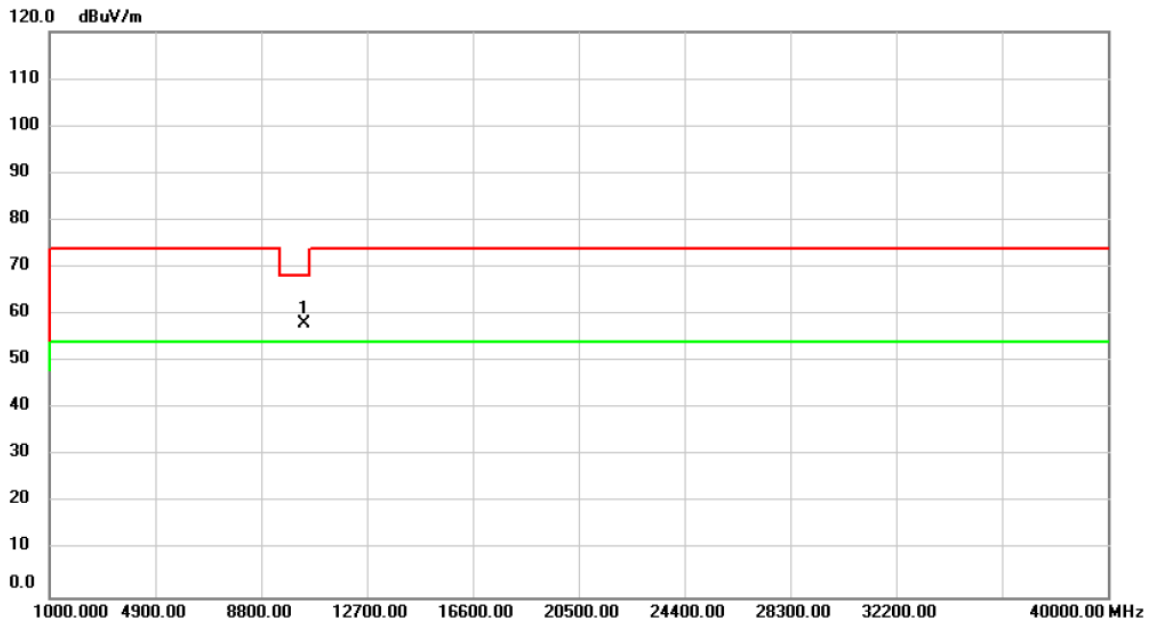

No.	Mk.	Freq.	Reading Level	Correct Factor	Measurement	Limit	Over	Detector	Comment
		MHz	dBuV	dB	dBuV/m	dBuV/m	dB		
1	*	10360.00	54.39	3.68	58.07	68.20	-10.13	peak	

**REMARKS:**

- (1) Measurement Value = Reading Level + Correct Factor.
- (2) Margin Level = Measurement Value - Limit Value.

Test Mode	UNII-1_IEEE 802.11n (HT20)	Test Date	2020/5/4
Test Frequency	CH36: 5180 MHz	Polarization	Horizontal

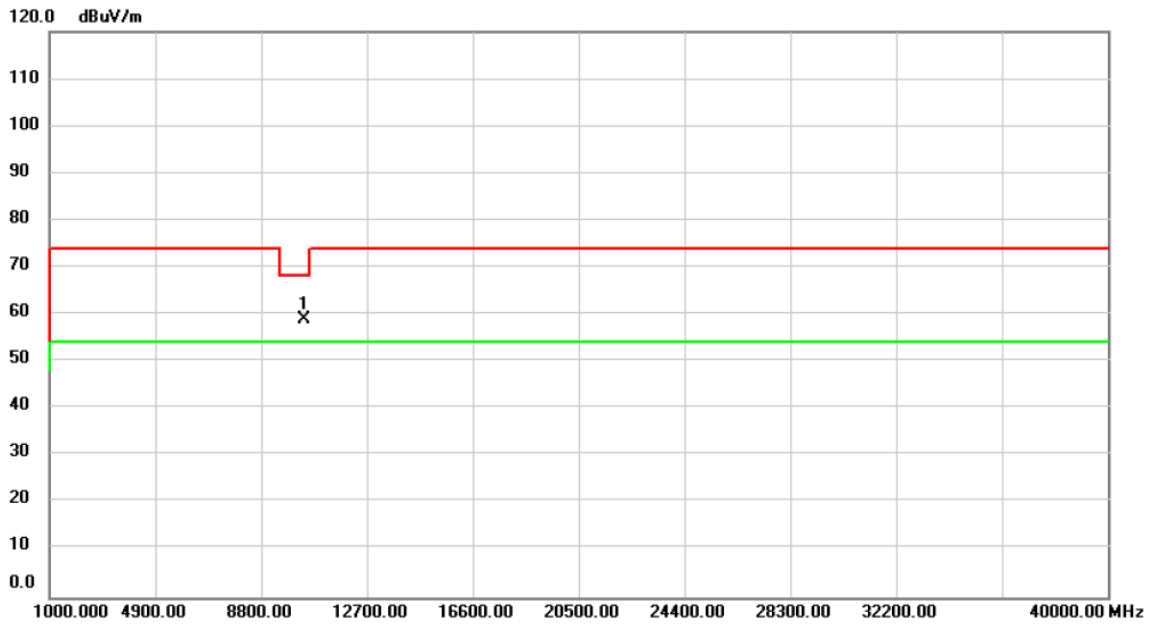

No.	Mk.	Freq.	Reading Level	Correct Factor	Measurement	Limit	Over	Detector	Comment
		MHz	dBuV	dB	dBuV/m	dBuV/m	dB		
1	*	10360.00	55.22	3.68	58.90	68.20	-9.30	peak	

**REMARKS:**

- (1) Measurement Value = Reading Level + Correct Factor.
- (2) Margin Level = Measurement Value - Limit Value.

Test Mode	UNII-1_IEEE 802.11n (HT20)	Test Date	2020/5/4
Test Frequency	CH40: 5200 MHz	Polarization	Vertical

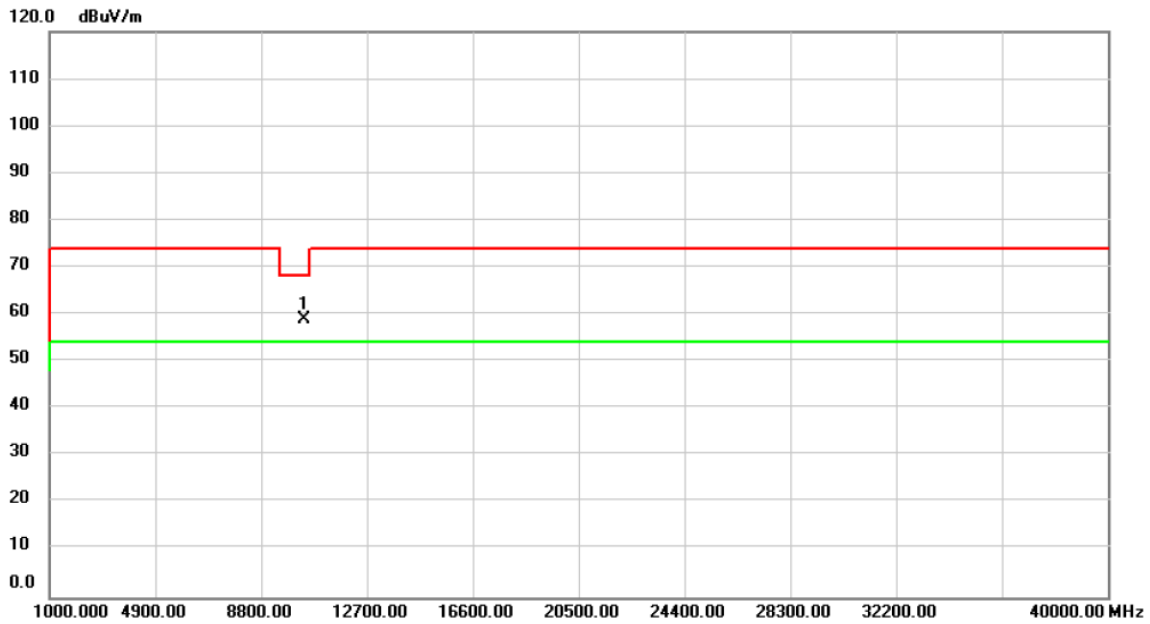

No.	Mk.	Freq.	Reading Level	Correct Factor	Measurement	Limit	Over	Detector	Comment
		MHz	dBuV	dB	dBuV/m	dBuV/m	dB		
1	*	10400.00	55.13	3.74	58.87	68.20	-9.33	peak	

**REMARKS:**

- (1) Measurement Value = Reading Level + Correct Factor.
- (2) Margin Level = Measurement Value - Limit Value.



Test Mode	UNII-1_IEEE 802.11n (HT20)	Test Date	2020/5/4
Test Frequency	CH40: 5200 MHz	Polarization	Horizontal

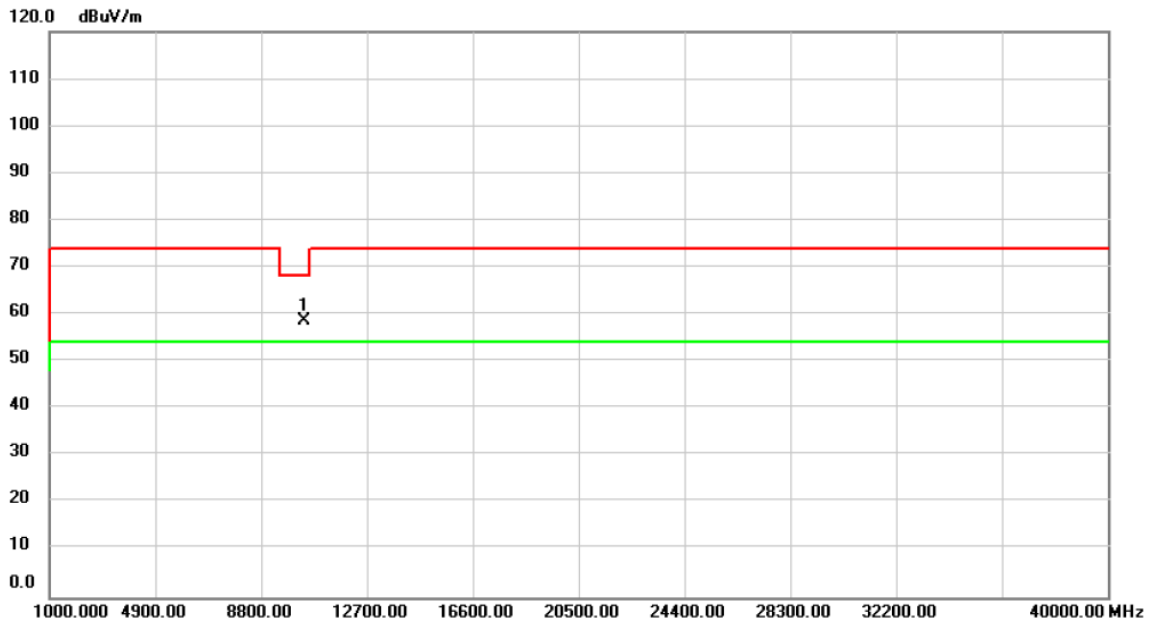

No.	Mk.	Freq.	Reading Level	Correct Factor	Measurement	Limit	Over	Detector	Comment
		MHz	dBuV	dB	dBuV/m	dBuV/m	dB		
1	*	10400.00	54.96	3.74	58.70	68.20	-9.50	peak	

**REMARKS:**

- (1) Measurement Value = Reading Level + Correct Factor.
- (2) Margin Level = Measurement Value - Limit Value.

Test Mode	UNII-1_IEEE 802.11n (HT20)	Test Date	2020/5/4
Test Frequency	CH48: 5240 MHz	Polarization	Vertical

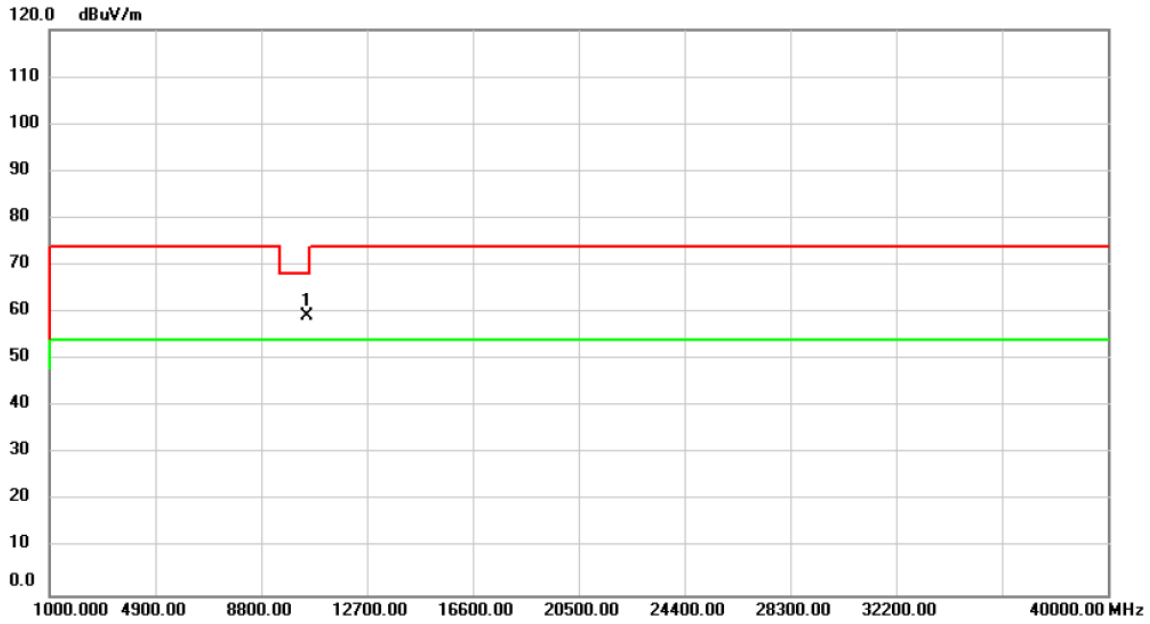

No.	Mk.	Freq.	Reading Level	Correct Factor	Measurement	Limit	Over	Detector	Comment
		MHz	dBuV	dB	dBuV/m	dBuV/m	dB		
1	*	10480.00	55.32	3.84	59.16	68.20	-9.04	peak	

**REMARKS:**

- (1) Measurement Value = Reading Level + Correct Factor.
- (2) Margin Level = Measurement Value - Limit Value.

Test Mode	UNII-1_IEEE 802.11n (HT20)	Test Date	2020/5/4
Test Frequency	CH48: 5240 MHz	Polarization	Horizontal

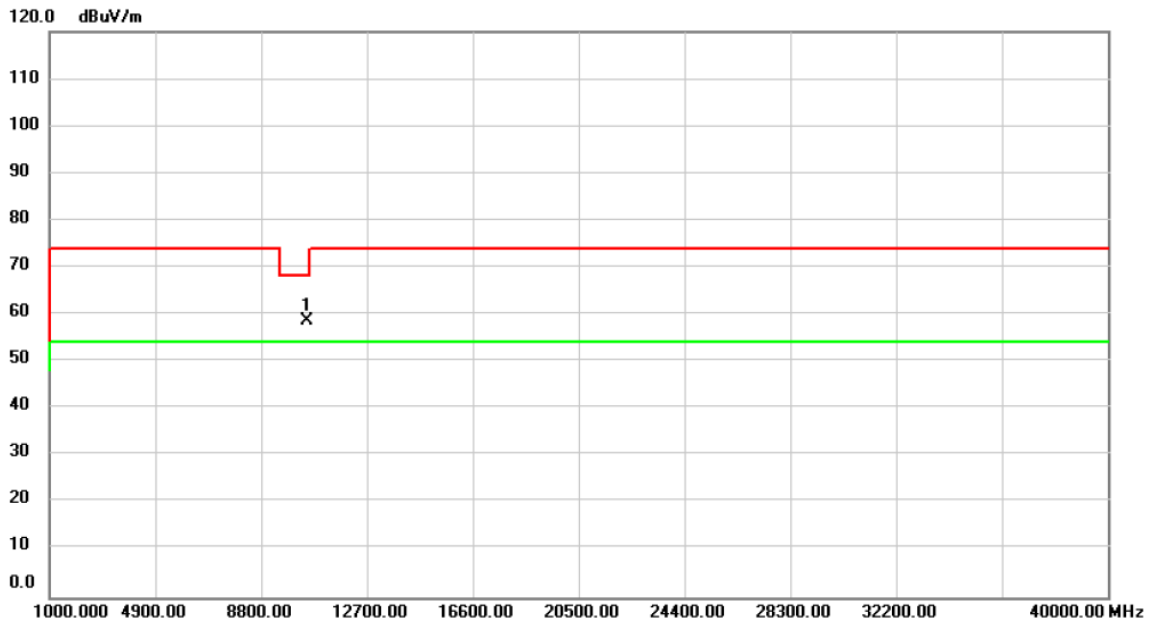

No.	Mk.	Freq.	Reading Level	Correct Factor	Measurement	Limit	Over	Detector	Comment
		MHz	dBuV	dB	dBuV/m	dBuV/m	dB		
1	*	10480.00	54.92	3.84	58.76	68.20	-9.44	peak	

**REMARKS:**

- (1) Measurement Value = Reading Level + Correct Factor.
- (2) Margin Level = Measurement Value - Limit Value.

Test Mode	UNII-3_IEEE 802.11n (HT20)	Test Date	2020/5/4
Test Frequency	CH149: 5745 MHz	Polarization	Vertical

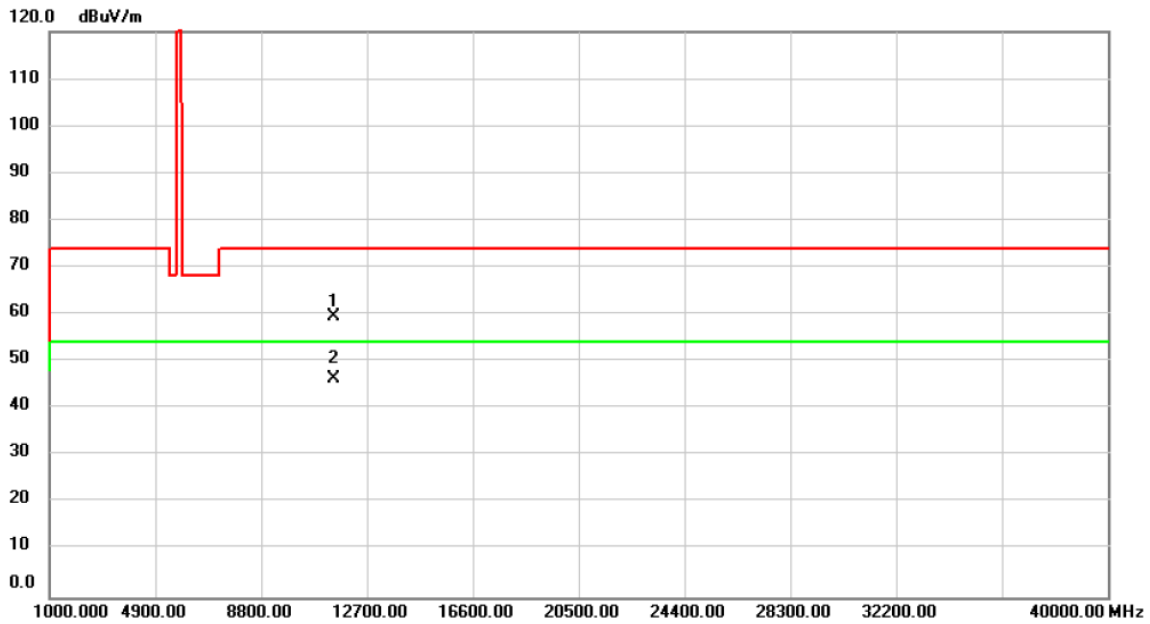

No.	Mk.	Freq.	Reading Level	Correct Factor	Measurement	Limit	Over	Detector	Comment
		MHz	dBuV	dB	dBuV/m	dBuV/m	dB		
1		11490.00	54.55	5.11	59.66	74.00	-14.34	peak	
2	*	11490.00	41.17	5.11	46.28	54.00	-7.72	AVG	

**REMARKS:**

- (1) Measurement Value = Reading Level + Correct Factor.
- (2) Margin Level = Measurement Value - Limit Value.

Test Mode	UNII-3_IEEE 802.11n (HT20)	Test Date	2020/5/4
Test Frequency	CH149: 5745 MHz	Polarization	Horizontal

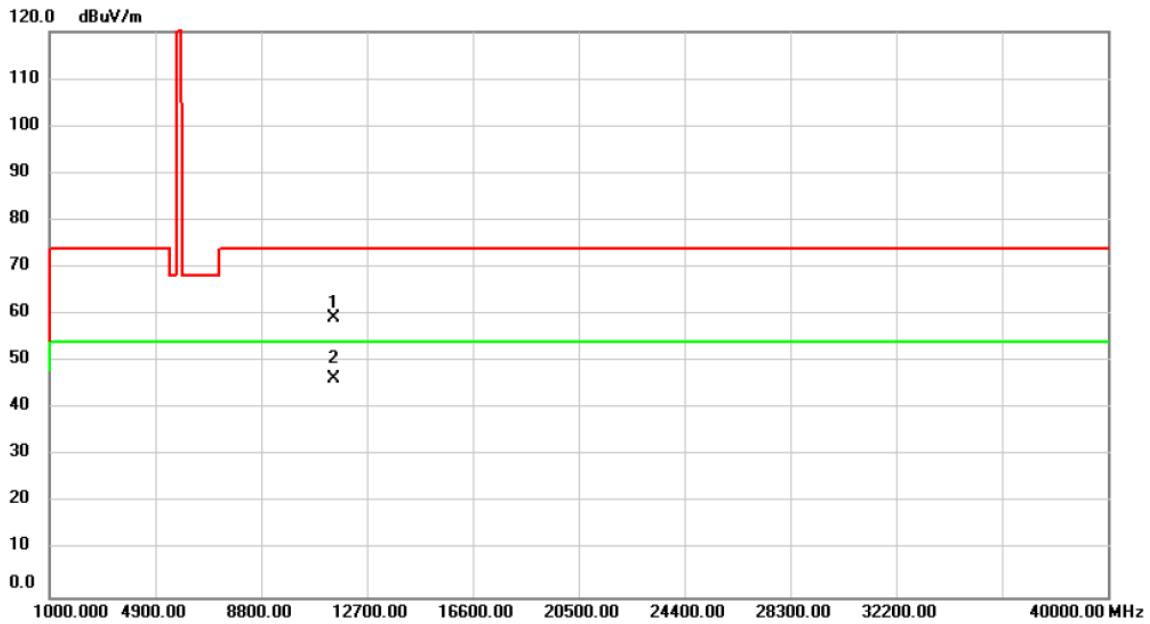

No.	Mk.	Freq. MHz	Reading Level dBuV	Correct Factor dB	Measure- ment dBuV/m	Limit dBuV/m	Over dB	Detector	Comment
1		11490.00	54.28	5.11	59.39	74.00	-14.61	peak	
2	*	11490.00	41.34	5.11	46.45	54.00	-7.55	AVG	

**REMARKS:**

- (1) Measurement Value = Reading Level + Correct Factor.
- (2) Margin Level = Measurement Value - Limit Value.

Test Mode	UNII-3_IEEE 802.11n (HT20)	Test Date	2020/4/21
Test Frequency	CH157: 5785 MHz	Polarization	Vertical

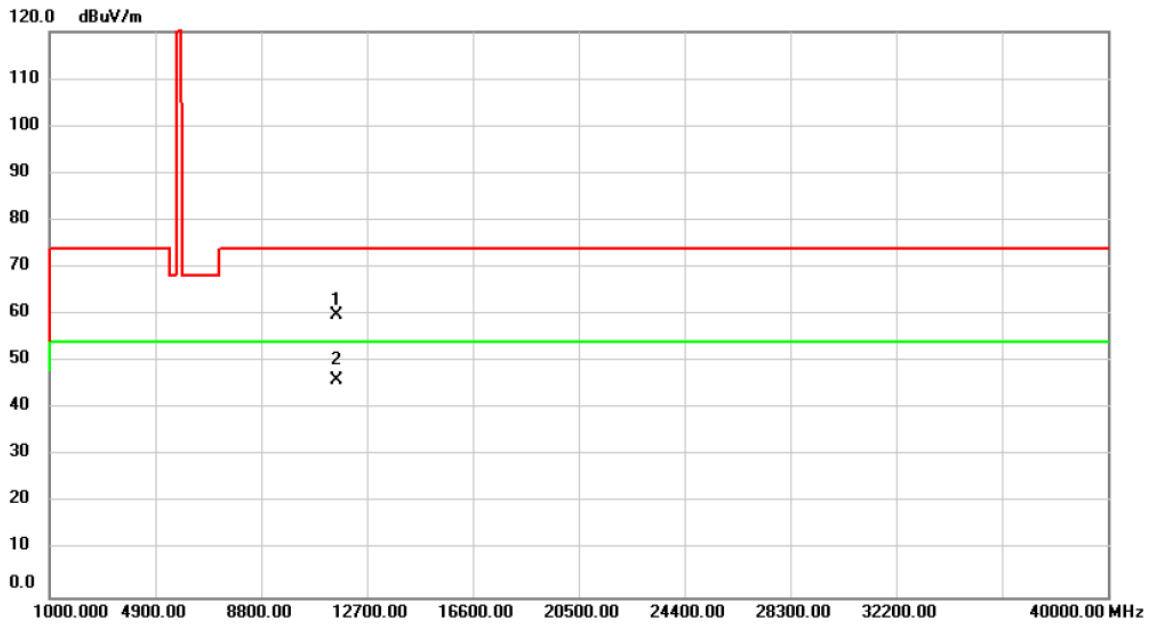

No.	Mk.	Freq.	Reading Level	Correct Factor	Measurement	Limit	Over	Detector	Comment
		MHz	dBuV	dB	dBuV/m	dBuV/m	dB		
1		11570.00	55.12	4.78	59.90	74.00	-14.10	peak	
2	*	11570.00	41.40	4.78	46.18	54.00	-7.82	AVG	

**REMARKS:**

- (1) Measurement Value = Reading Level + Correct Factor.
- (2) Margin Level = Measurement Value - Limit Value.

Test Mode	UNII-3_IEEE 802.11n (HT20)	Test Date	2020/4/21
Test Frequency	CH157: 5785 MHz	Polarization	Horizontal

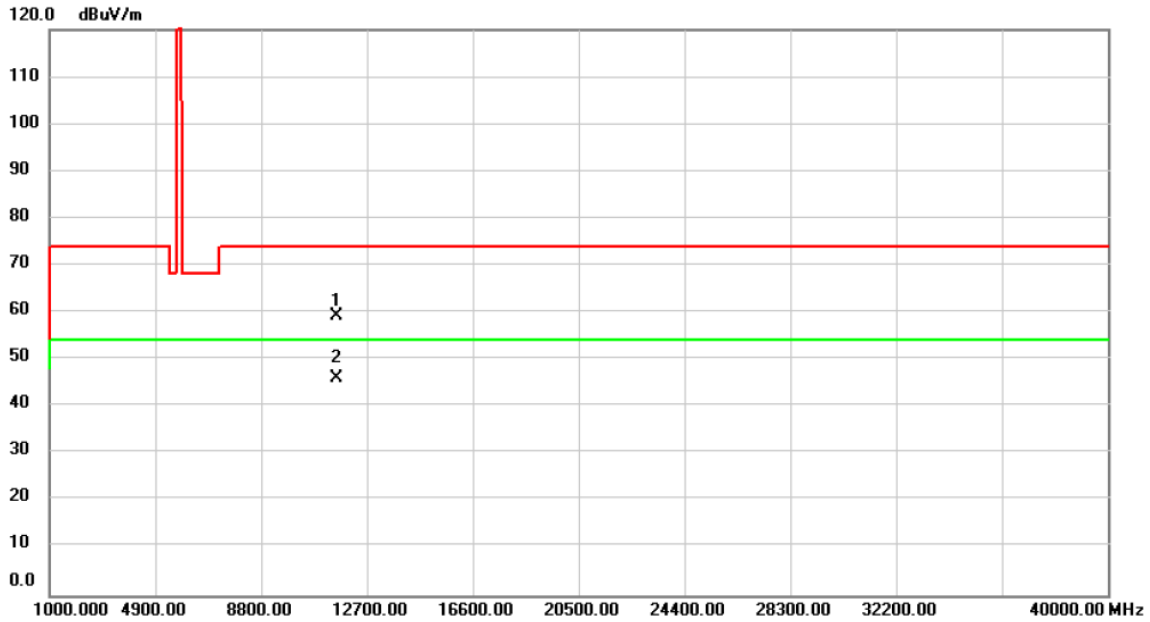

No.	Mk.	Freq.	Reading Level	Correct Factor	Measurement	Limit	Over	Detector	Comment
		MHz	dBuV	dB	dBuV/m	dBuV/m	dB		
1		11570.00	54.35	4.78	59.13	74.00	-14.87	peak	
2	*	11570.00	41.33	4.78	46.11	54.00	-7.89	AVG	

**REMARKS:**

- (1) Measurement Value = Reading Level + Correct Factor.
- (2) Margin Level = Measurement Value - Limit Value.

Test Mode	UNII-3_IEEE 802.11n (HT20)	Test Date	2020/5/4
Test Frequency	CH165: 5825 MHz	Polarization	Vertical

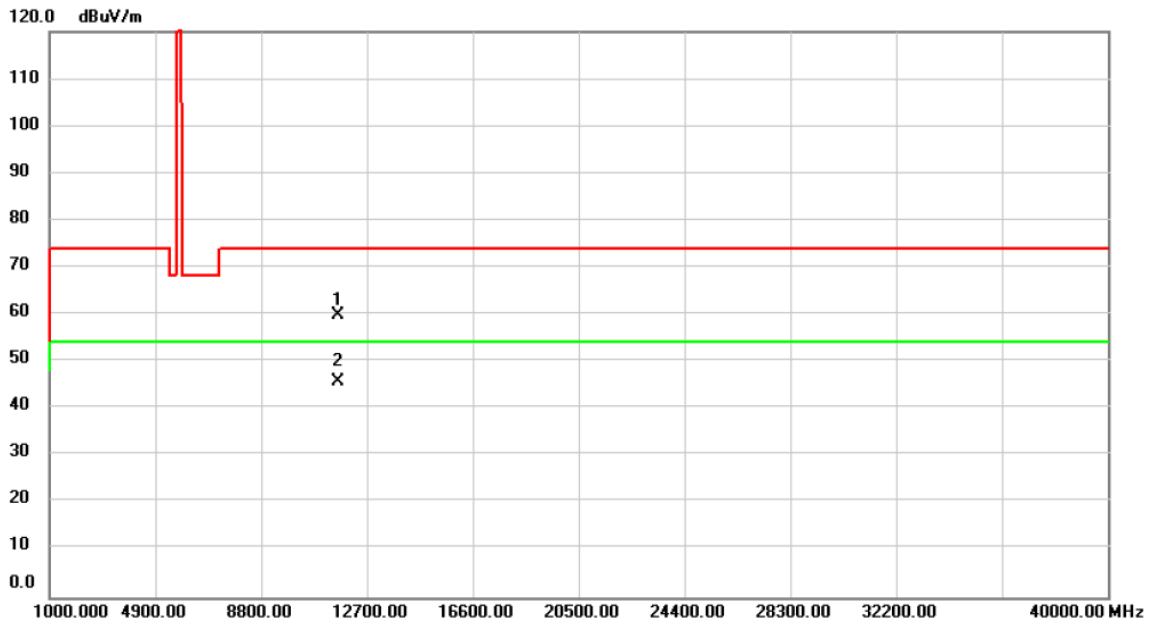

No.	Mk.	Freq.	Reading Level	Correct Factor	Measurement	Limit	Over	Detector	Comment
		MHz	dBuV	dB	dBuV/m	dBuV/m	dB		
1		11650.00	55.58	4.40	59.98	74.00	-14.02	peak	
2	*	11650.00	41.34	4.40	45.74	54.00	-8.26	AVG	

**REMARKS:**

- (1) Measurement Value = Reading Level + Correct Factor.
- (2) Margin Level = Measurement Value - Limit Value.



Test Mode	UNII-3_IEEE 802.11n (HT20)	Test Date	2020/5/4
Test Frequency	CH165: 5825 MHz	Polarization	Horizontal

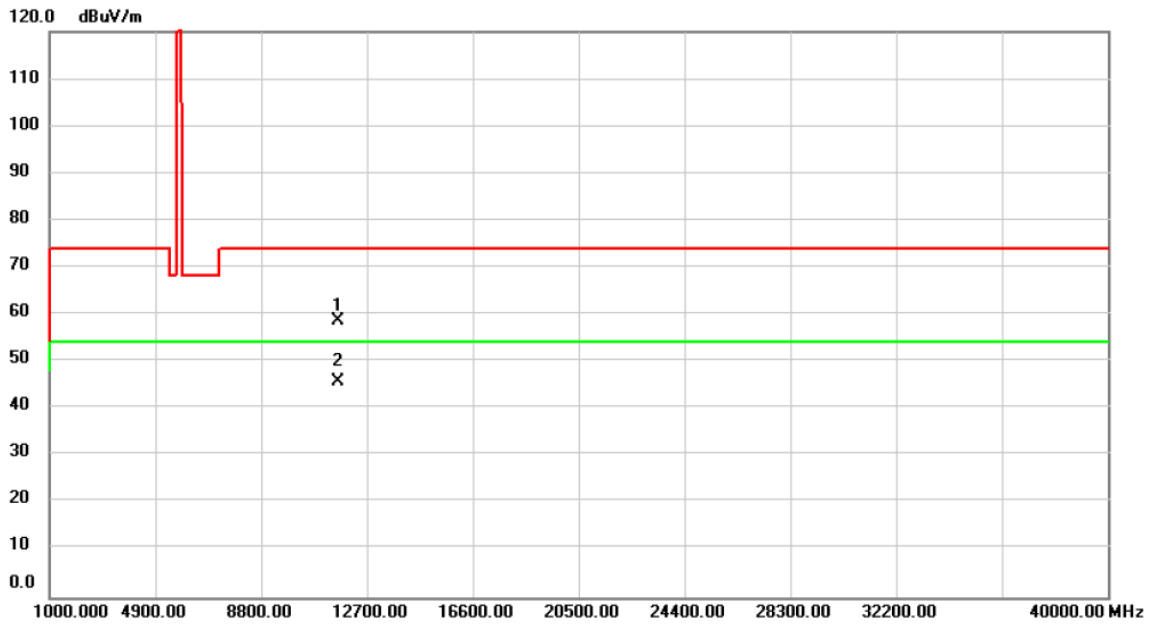

No.	Mk.	Freq. MHz	Reading Level dBuV	Correct Factor dB	Measure- ment dBuV/m	Limit dBuV/m	Over dB	Detector	Comment
1		11650.00	54.23	4.40	58.63	74.00	-15.37	peak	
2	*	11650.00	41.27	4.40	45.67	54.00	-8.33	AVG	

**REMARKS:**

- (1) Measurement Value = Reading Level + Correct Factor.
- (2) Margin Level = Measurement Value - Limit Value.

Test Mode	UNII-1_IEEE 802.11n (HT40)	Test Date	2020/5/4
Test Frequency	CH38: 5190 MHz	Polarization	Vertical

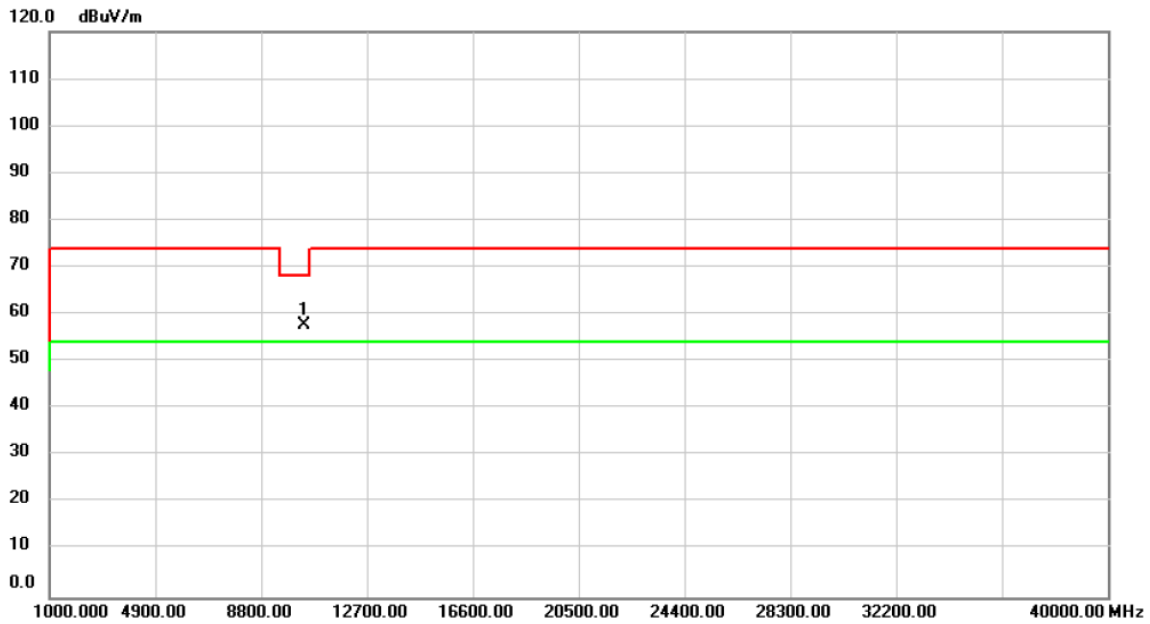

No.	Mk.	Freq.	Reading Level	Correct Factor	Measurement	Limit	Over	Detector	Comment
		MHz	dBuV	dB	dBuV/m	dBuV/m	dB		
1	*	10380.00	53.91	3.71	57.62	68.20	-10.58	peak	

**REMARKS:**

- (1) Measurement Value = Reading Level + Correct Factor.
- (2) Margin Level = Measurement Value - Limit Value.

Test Mode	UNII-1_IEEE 802.11n (HT40)	Test Date	2020/5/4
Test Frequency	CH38: 5190 MHz	Polarization	Horizontal

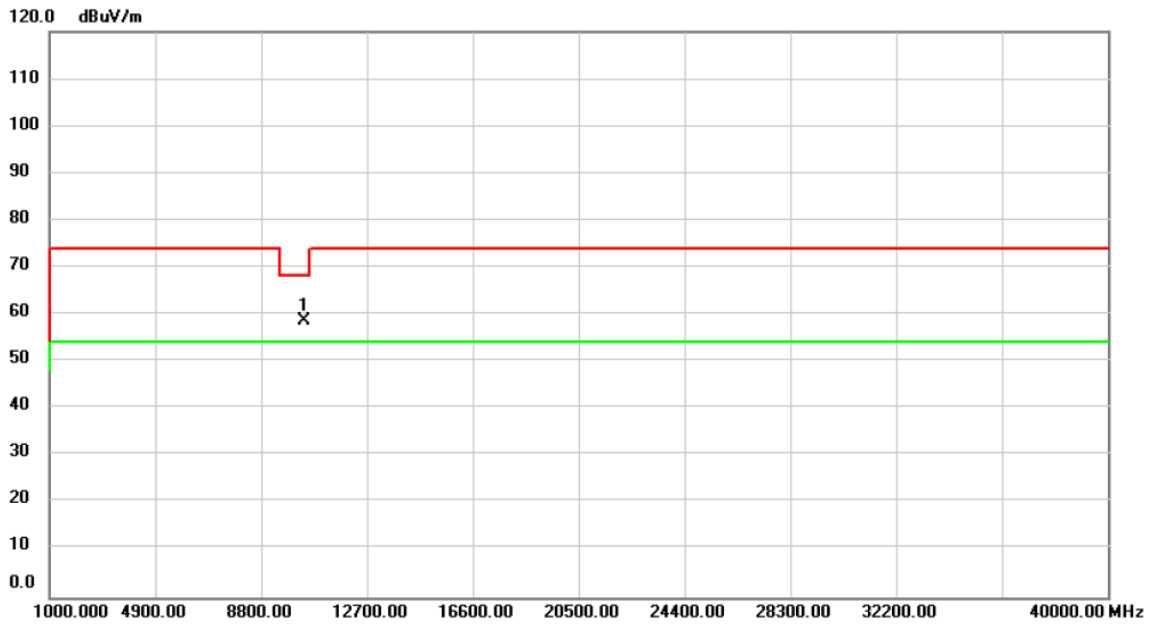

No.	Mk.	Freq.	Reading Level	Correct Factor	Measurement	Limit	Over	Detector	Comment
		MHz	dBuV	dB	dBuV/m	dBuV/m	dB		
1	*	10380.00	55.09	3.71	58.80	68.20	-9.40	peak	

**REMARKS:**

- (1) Measurement Value = Reading Level + Correct Factor.
- (2) Margin Level = Measurement Value - Limit Value.

Test Mode	UNII-1_IEEE 802.11n (HT40)	Test Date	2020/5/4
Test Frequency	CH46: 5230 MHz	Polarization	Vertical

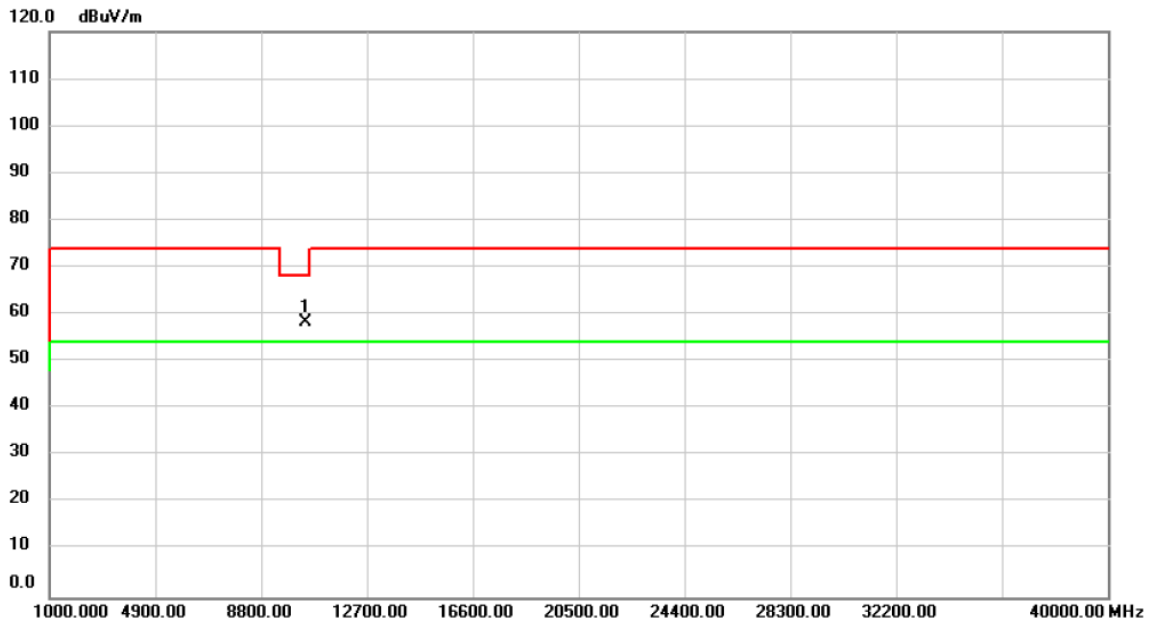

No.	Mk.	Freq.	Reading Level	Correct Factor	Measurement	Limit	Over	Detector	Comment
		MHz	dBuV	dB	dBuV/m	dBuV/m	dB		
1	*	10460.00	54.43	3.82	58.25	68.20	-9.95	peak	

**REMARKS:**

- (1) Measurement Value = Reading Level + Correct Factor.
- (2) Margin Level = Measurement Value - Limit Value.

Test Mode	UNII-1_IEEE 802.11n (HT40)	Test Date	2020/5/4
Test Frequency	CH46: 5230 MHz	Polarization	Horizontal

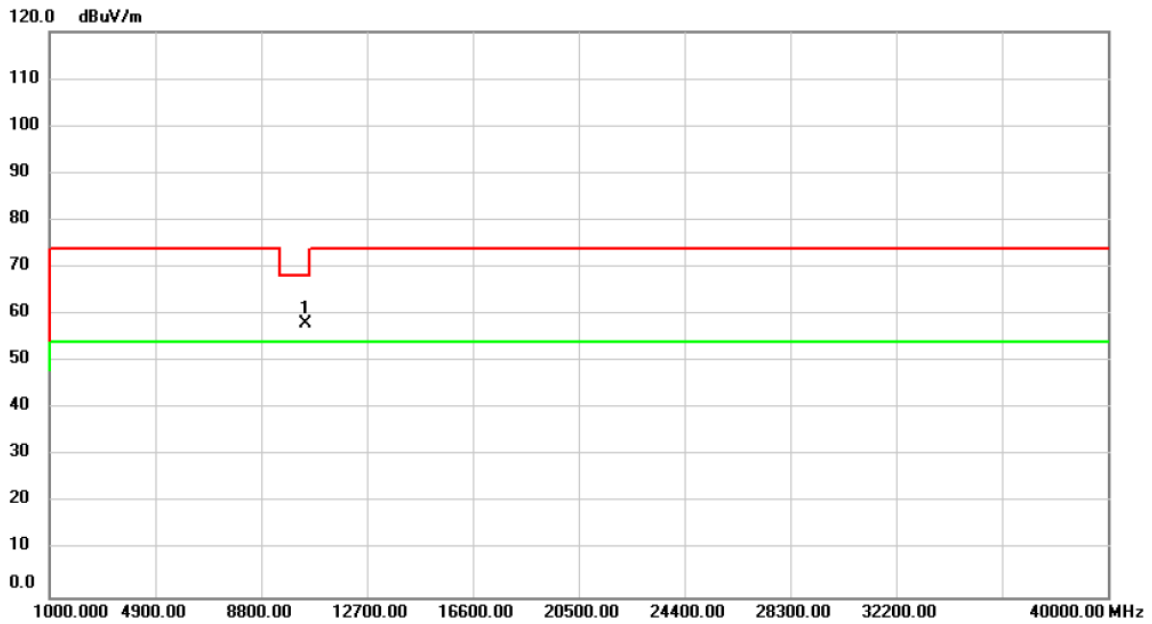

No.	Mk.	Freq.	Reading Level	Correct Factor	Measurement	Limit	Over	Detector	Comment
		MHz	dBuV	dB	dBuV/m	dBuV/m	dB		
1	*	10460.00	54.09	3.82	57.91	68.20	-10.29	peak	

**REMARKS:**

- (1) Measurement Value = Reading Level + Correct Factor.
- (2) Margin Level = Measurement Value - Limit Value.

Test Mode	UNII-3_IEEE 802.11n (HT40)	Test Date	2020/5/4
Test Frequency	CH151: 5755 MHz	Polarization	Vertical

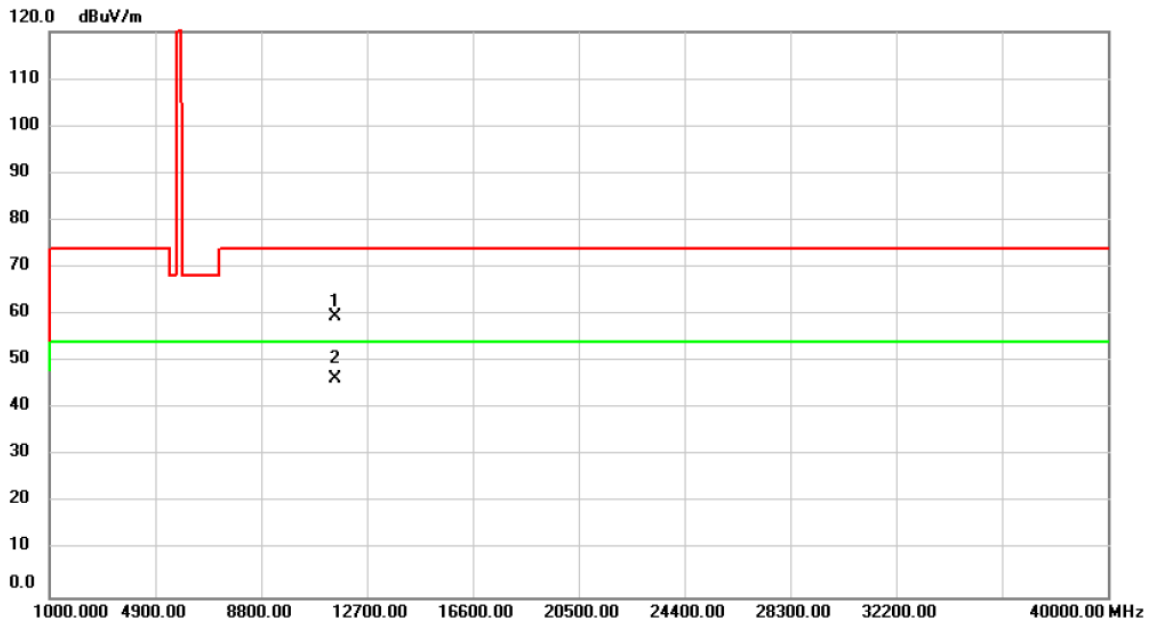

No.	Mk.	Freq.	Reading Level	Correct Factor	Measurement	Limit	Over	Detector	Comment
		MHz	dBuV	dB	dBuV/m	dBuV/m	dB		
1		11510.00	54.55	5.07	59.62	74.00	-14.38	peak	
2	*	11510.00	41.37	5.07	46.44	54.00	-7.56	AVG	

**REMARKS:**

- (1) Measurement Value = Reading Level + Correct Factor.
- (2) Margin Level = Measurement Value - Limit Value.

Test Mode	UNII-3_IEEE 802.11n (HT40)	Test Date	2020/5/4
Test Frequency	CH151: 5755 MHz	Polarization	Horizontal

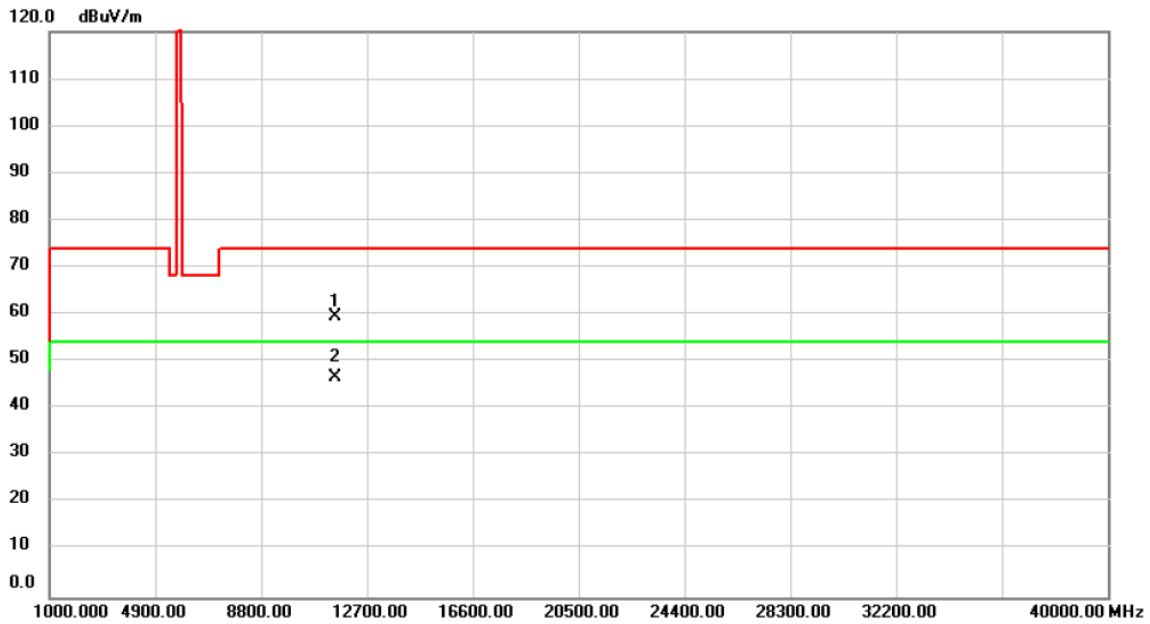

No.	Mk.	Freq.	Reading Level	Correct Factor	Measurement	Limit	Over	Detector	Comment
		MHz	dBuV	dB	dBuV/m	dBuV/m	dB		
1		11510.00	54.58	5.07	59.65	74.00	-14.35	peak	
2	*	11510.00	41.54	5.07	46.61	54.00	-7.39	AVG	

**REMARKS:**

- (1) Measurement Value = Reading Level + Correct Factor.
- (2) Margin Level = Measurement Value - Limit Value.

Test Mode	UNII-3_IEEE 802.11n (HT40)	Test Date	2020/5/4
Test Frequency	CH159: 5795 MHz	Polarization	Vertical

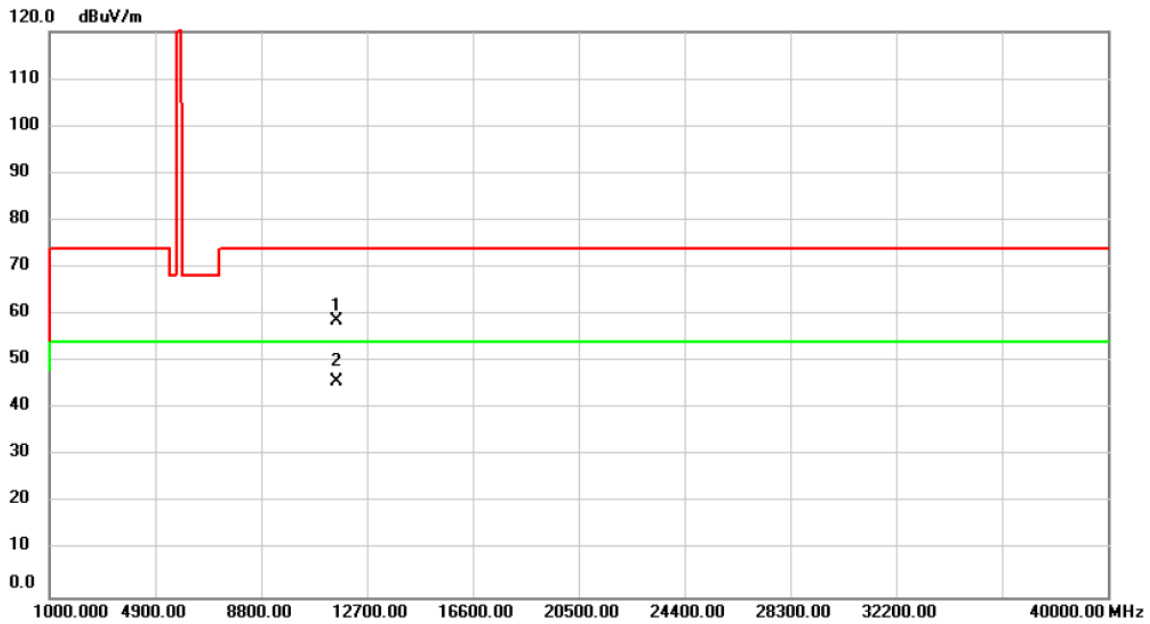

No.	Mk.	Freq.	Reading Level	Correct Factor	Measurement	Limit	Over	Detector	Comment
		MHz	dBuV	dB	dBuV/m	dBuV/m	dB		
1		11590.00	54.06	4.69	58.75	74.00	-15.25	peak	
2	*	11590.00	41.06	4.69	45.75	54.00	-8.25	AVG	

**REMARKS:**

- (1) Measurement Value = Reading Level + Correct Factor.
- (2) Margin Level = Measurement Value - Limit Value.



Test Mode	UNII-3_IEEE 802.11n (HT40)	Test Date	2020/5/4
Test Frequency	CH159: 5795 MHz	Polarization	Horizontal

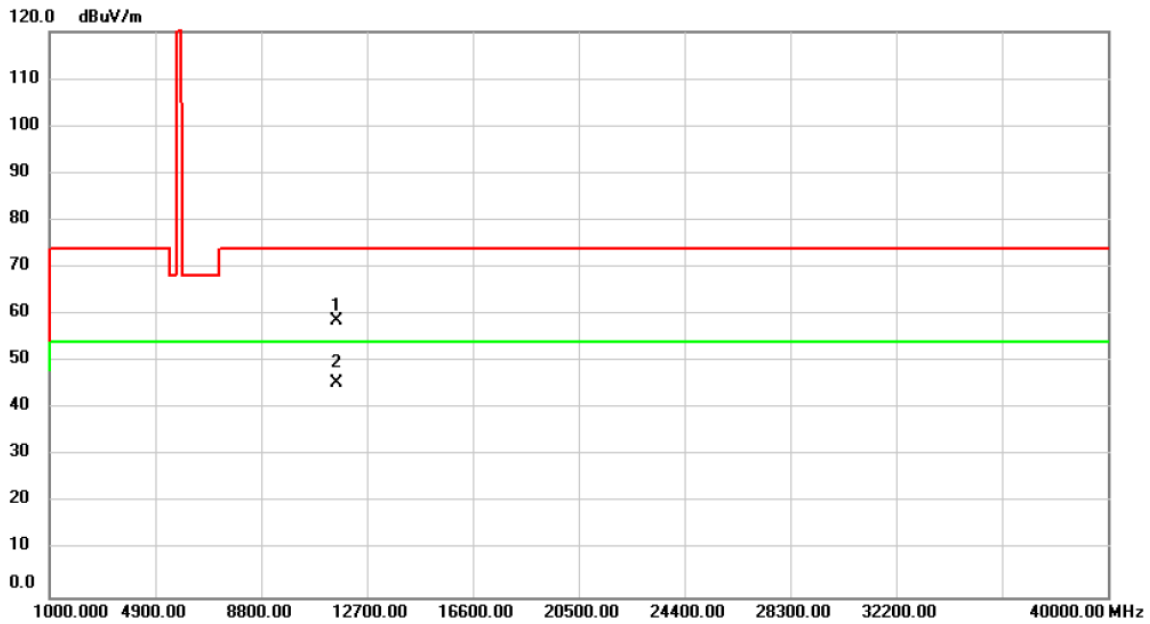

No.	Mk.	Freq.	Reading Level	Correct Factor	Measurement	Limit	Over	Detector	Comment
		MHz	dBuV	dB	dBuV/m	dBuV/m	dB		
1		11590.00	53.94	4.69	58.63	74.00	-15.37	peak	
2	*	11590.00	40.90	4.69	45.59	54.00	-8.41	AVG	

**REMARKS:**

- (1) Measurement Value = Reading Level + Correct Factor.
- (2) Margin Level = Measurement Value - Limit Value.

Test Mode	UNII-1_IEEE 802.11ac (VHT80)	Test Date	2020/5/4
Test Frequency	CH42: 5210 MHz	Polarization	Vertical

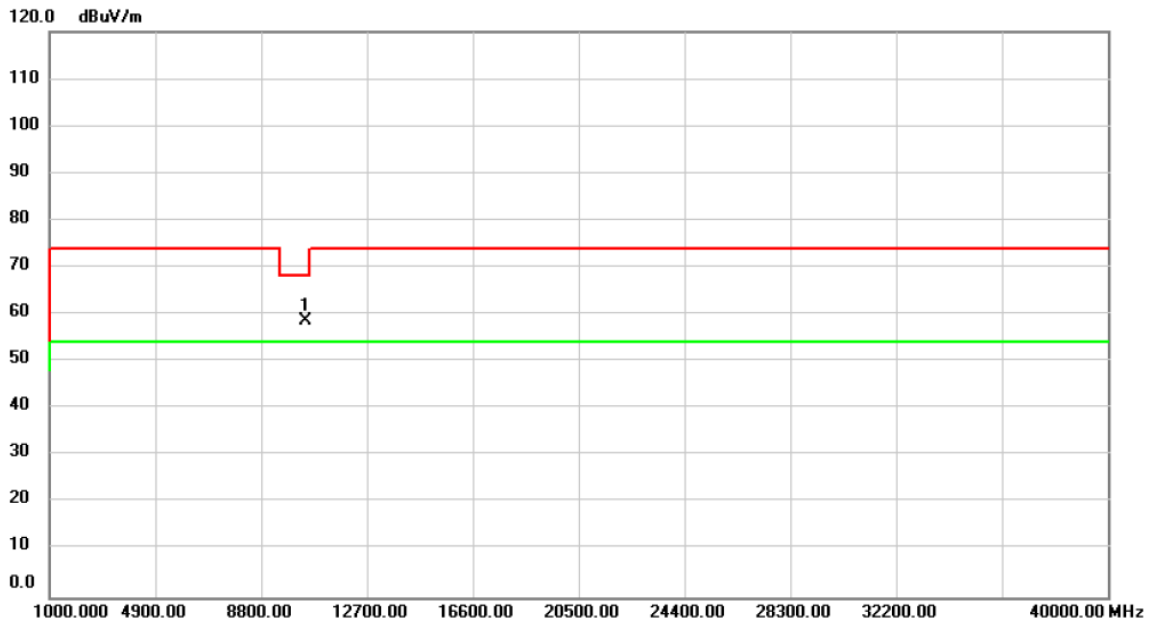

No.	Mk.	Freq.	Reading Level	Correct Factor	Measurement	Limit	Over	Detector	Comment
		MHz	dBuV	dB	dBuV/m	dBuV/m	dB		
1	*	10420.00	54.93	3.76	58.69	68.20	-9.51	peak	

**REMARKS:**

- (1) Measurement Value = Reading Level + Correct Factor.
- (2) Margin Level = Measurement Value - Limit Value.

Test Mode	UNII-1_IEEE 802.11ac (VHT80)	Test Date	2020/5/4
Test Frequency	CH42: 5210 MHz	Polarization	Horizontal

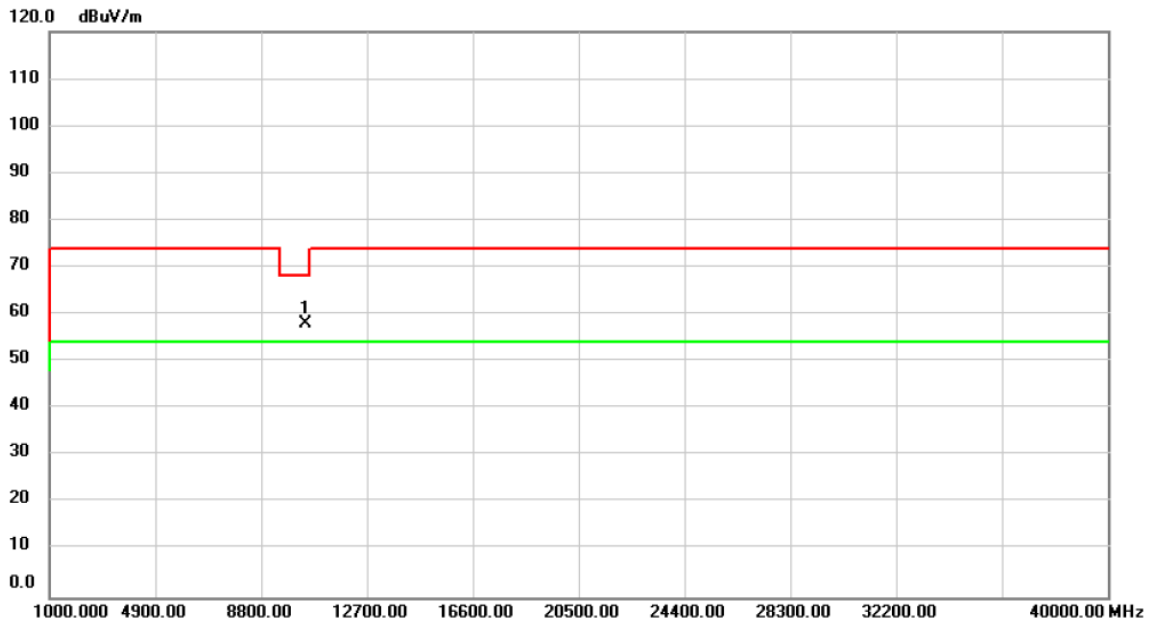

No.	Mk.	Freq.	Reading Level	Correct Factor	Measurement	Limit	Over	Detector	Comment
		MHz	dBuV	dB	dBuV/m	dBuV/m	dB		
1	*	10420.00	54.43	3.76	58.19	68.20	-10.01	peak	

**REMARKS:**

- (1) Measurement Value = Reading Level + Correct Factor.
- (2) Margin Level = Measurement Value - Limit Value.

Test Mode	UNII-3_IEEE 802.11ac (VHT80)	Test Date	2020/5/4
Test Frequency	CH155: 5775 MHz	Polarization	Vertical

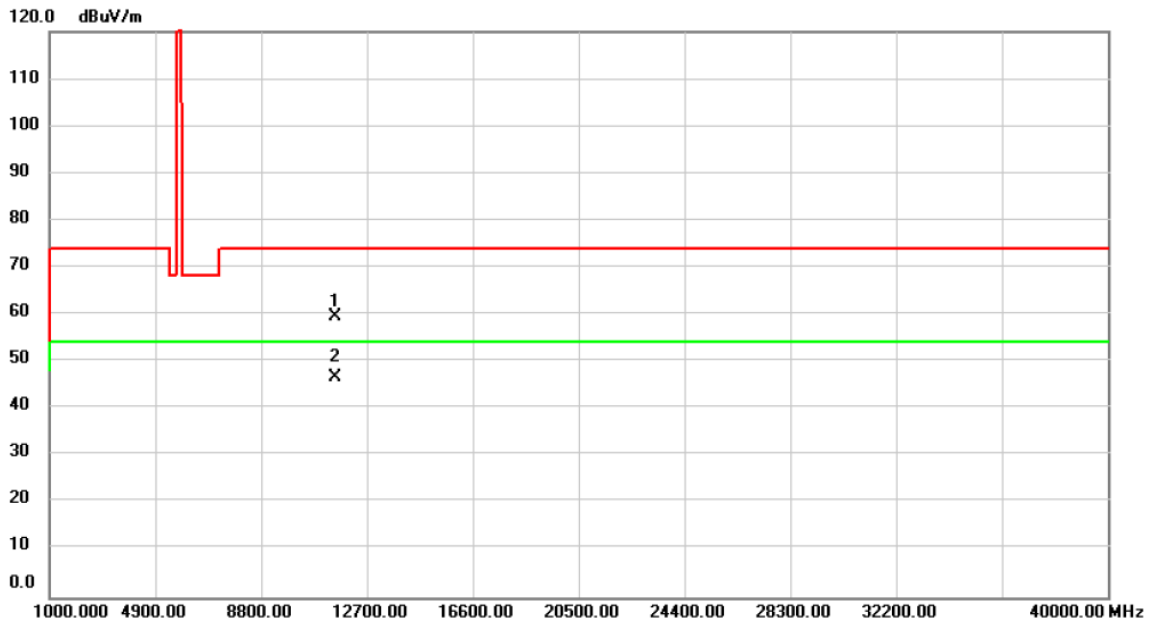

No.	Mk.	Freq.	Reading Level	Correct Factor	Measurement	Limit	Over	Detector	Comment
		MHz	dBuV	dB	dBuV/m	dBuV/m	dB		
1		11550.00	54.77	4.88	59.65	74.00	-14.35	peak	
2	*	11550.00	41.89	4.88	46.77	54.00	-7.23	AVG	

**REMARKS:**

- (1) Measurement Value = Reading Level + Correct Factor.
- (2) Margin Level = Measurement Value - Limit Value.

Test Mode	UNII-3_IEEE 802.11ac (VHT80)	Test Date	2020/5/4
Test Frequency	CH155: 5775 MHz	Polarization	Horizontal

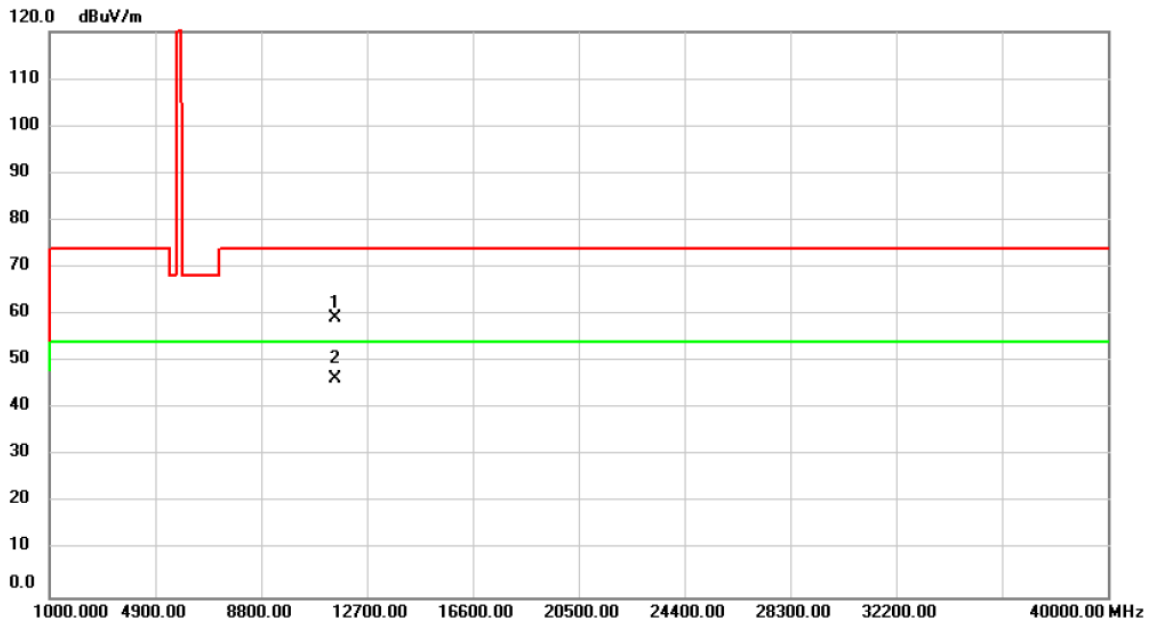

No.	Mk.	Freq.	Reading Level	Correct Factor	Measurement	Limit	Over	Detector	Comment
		MHz	dBuV	dB	dBuV/m	dBuV/m	dB		
1		11550.00	54.45	4.88	59.33	74.00	-14.67	peak	
2	*	11550.00	41.52	4.88	46.40	54.00	-7.60	AVG	

**REMARKS:**

- (1) Measurement Value = Reading Level + Correct Factor.
- (2) Margin Level = Measurement Value - Limit Value.

## APPENDIX C BANDWIDTH

Test Mode	IEEE 802.11a
-----------	--------------

Frequency (MHz)	26dB Bandwidth (MHz)	99% Occupied Bandwidth (MHz)
5180	34.19	18.20
5200	40.20	18.90
5240	39.79	19.50

### 26 dB Bandwidth

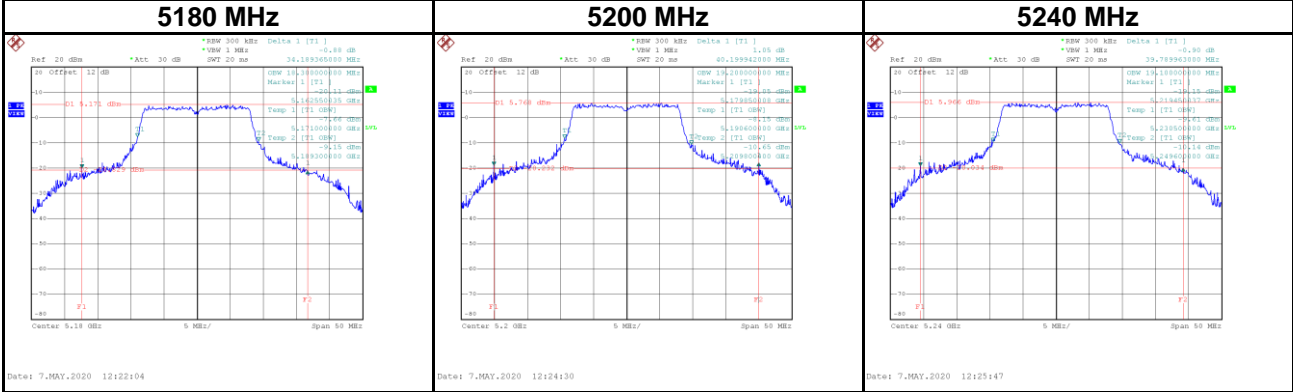

### 99 % Occupied Bandwidth

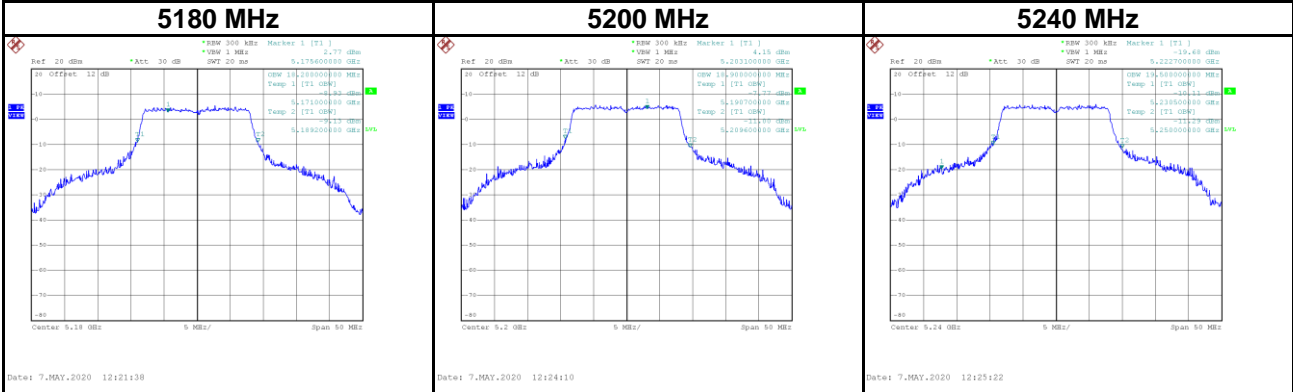

Frequency (MHz)	6dB Bandwidth (MHz)	99 % Occupied Bandwidth (MHz)	6 dB Bandwidth Limit (kHz)	Result
5745	16.41	17.90	500	Complies
5785	16.45	17.90	500	Complies
5825	16.50	17.90	500	Complies

### 6 dB Bandwidth

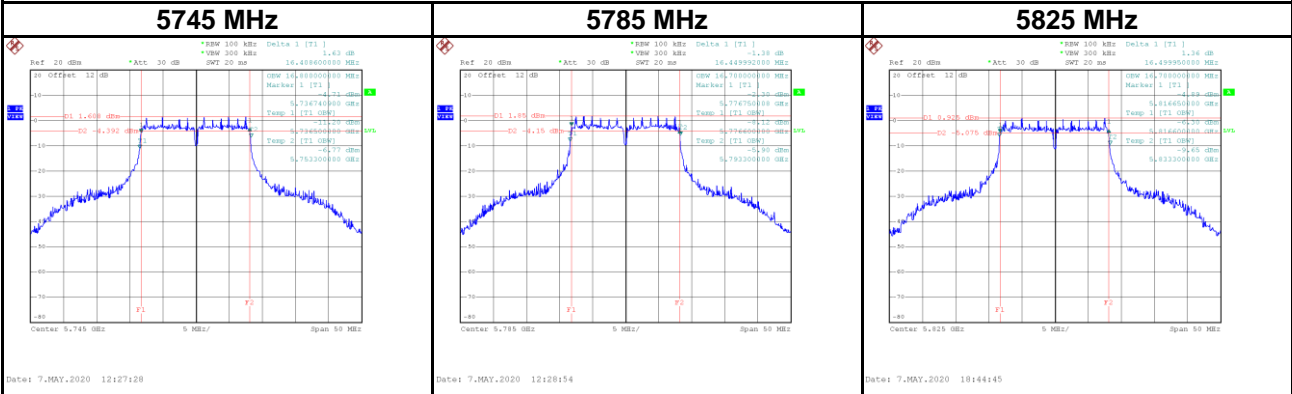

### 99 % Occupied Bandwidth

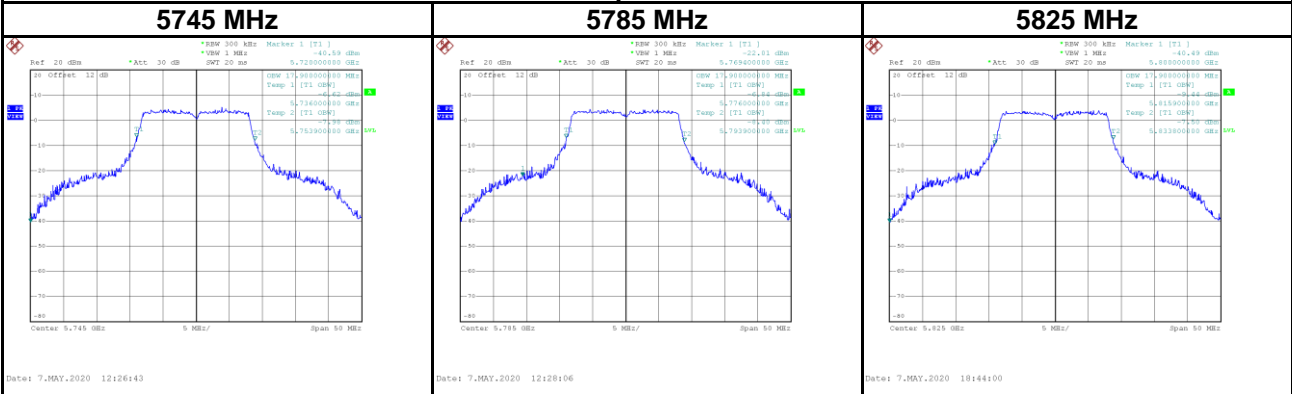



Test Mode	IEEE 802.11n (HT20)
-----------	---------------------

Frequency (MHz)	26dB Bandwidth (MHz)	99% Occupied Bandwidth (MHz)
5180	38.85	19.00
5200	40.85	19.90
5240	41.60	19.90

### 26 dB Bandwidth

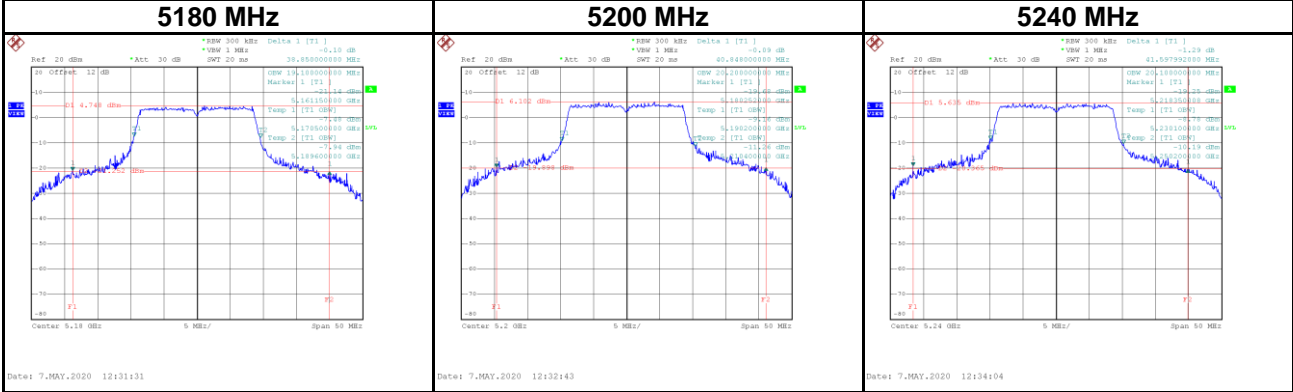

### 99 % Occupied Bandwidth

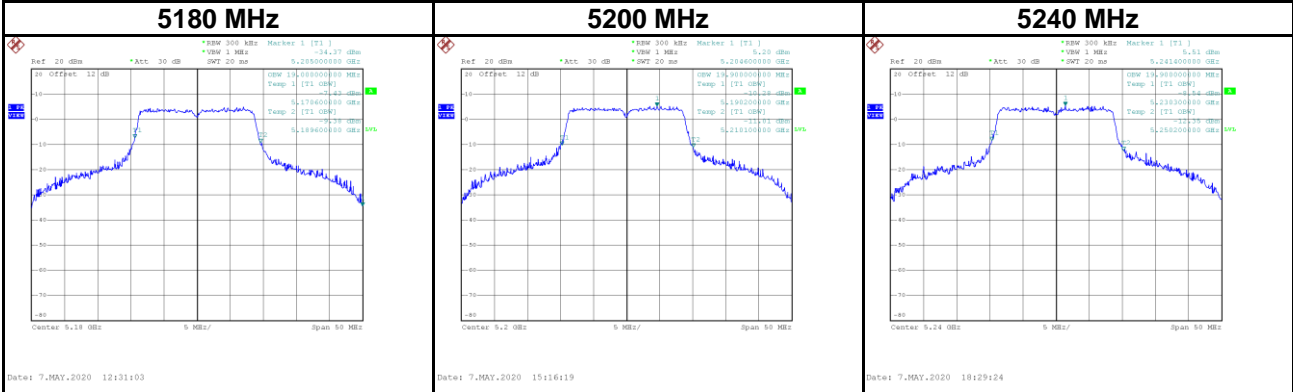

Frequency (MHz)	6dB Bandwidth (MHz)	99 % Occupied Bandwidth (MHz)	6 dB Bandwidth Limit (kHz)	Result
5745	17.65	18.70	500	Complies
5785	17.65	18.70	500	Complies
5825	17.55	18.80	500	Complies

### 6 dB Bandwidth

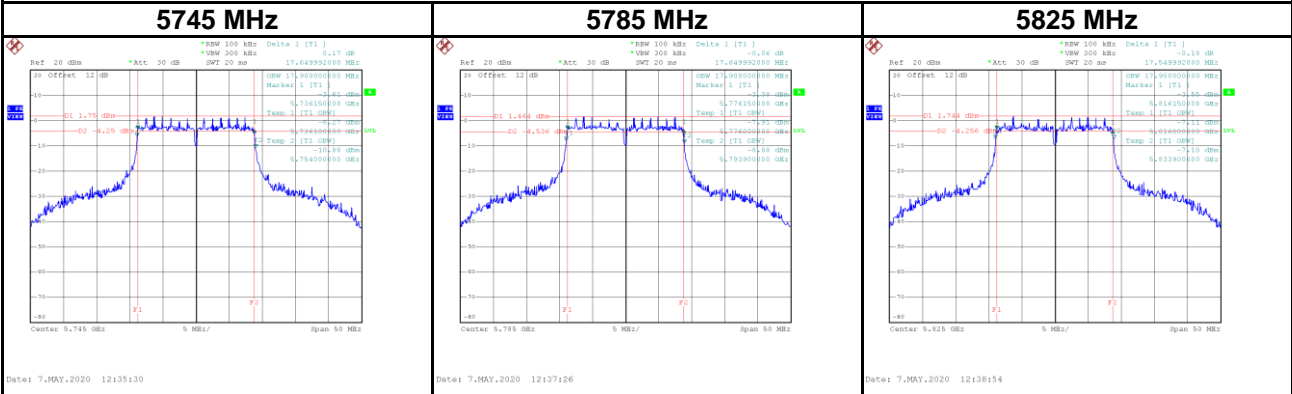

### 99 % Occupied Bandwidth

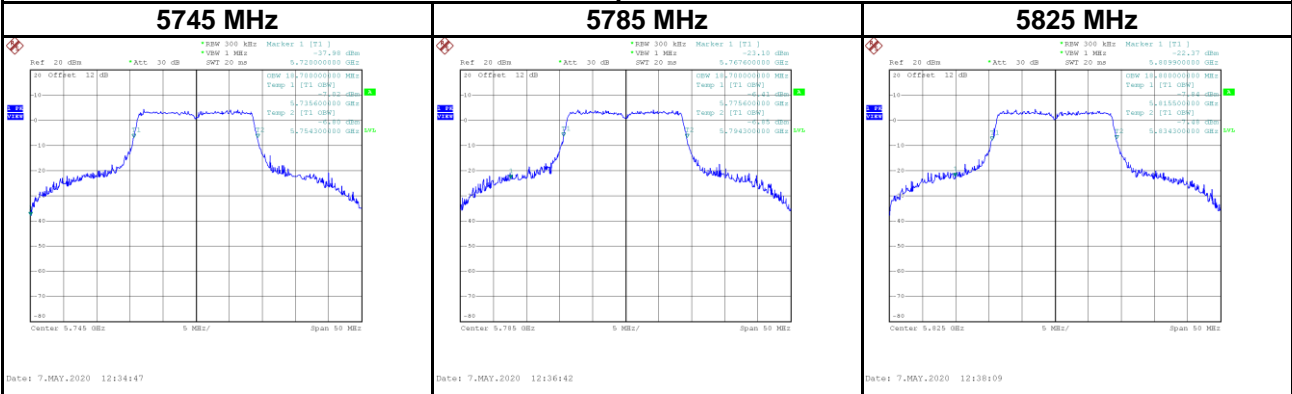

Test Mode	IEEE 802.11n (HT40)
-----------	---------------------

Frequency (MHz)	26dB Bandwidth (MHz)	99% Occupied Bandwidth (MHz)
5190	42.79	37.40
5230	82.10	39.20

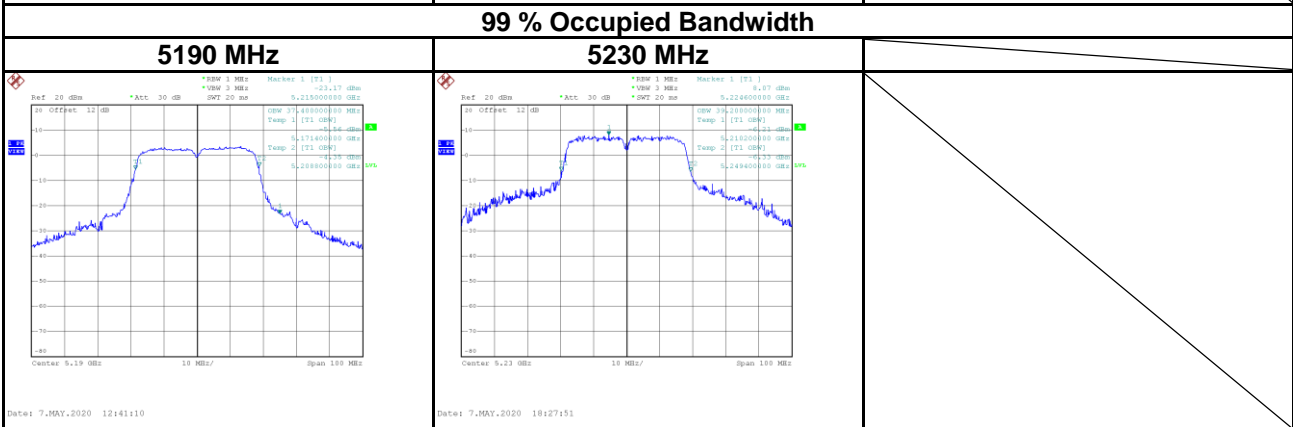
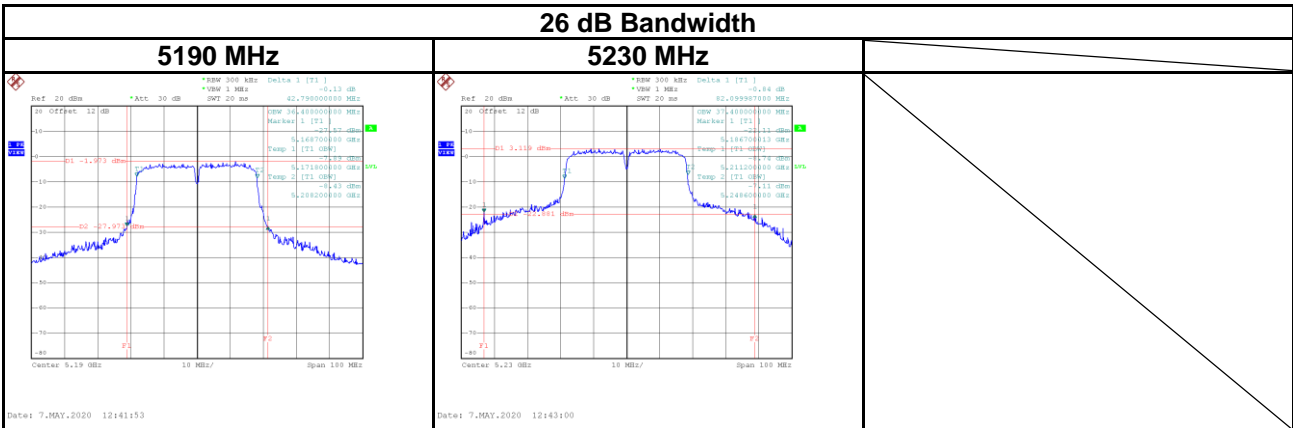

Frequency (MHz)	6dB Bandwidth (MHz)	99 % Occupied Bandwidth (MHz)	6 dB Bandwidth Limit (kHz)	Result
5755	35.30	38.40	500	Complies
5795	35.41	38.60	500	Complies

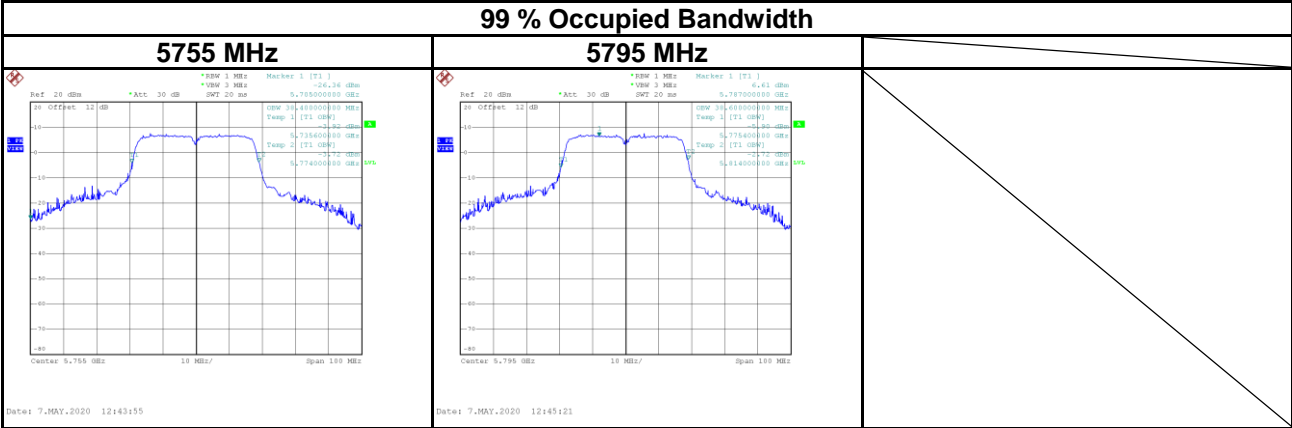
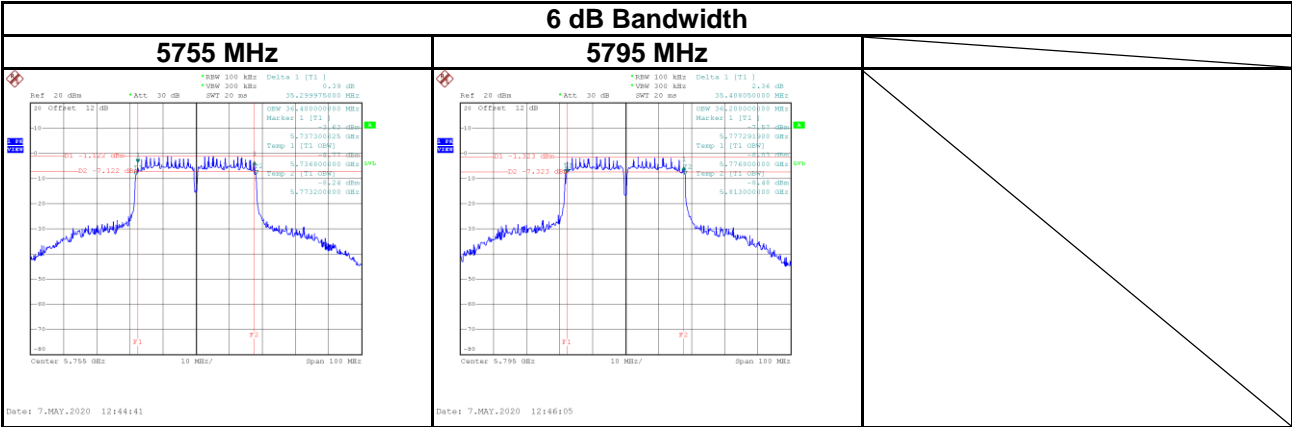

Test Mode	IEEE 802.11ac (VHT80)
-----------	-----------------------

Frequency (MHz)	26dB Bandwidth (MHz)	99% Occupied Bandwidth (MHz)
5210	87.19	75.60

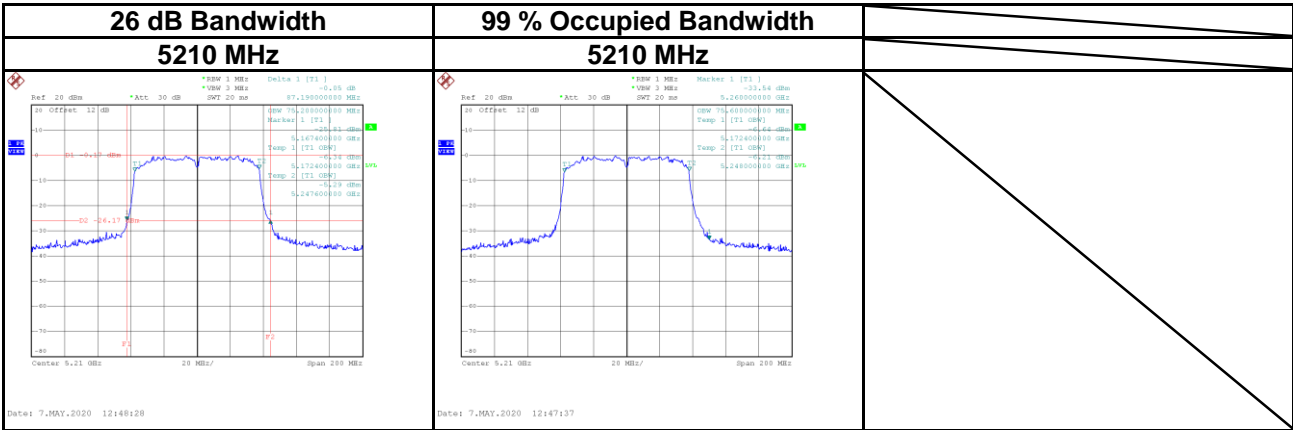

Frequency (MHz)	6dB Bandwidth (MHz)	99 % Occupied Bandwidth (MHz)	6 dB Bandwidth Limit (kHz)	Result
5775	74.60	76.80	500	Complies

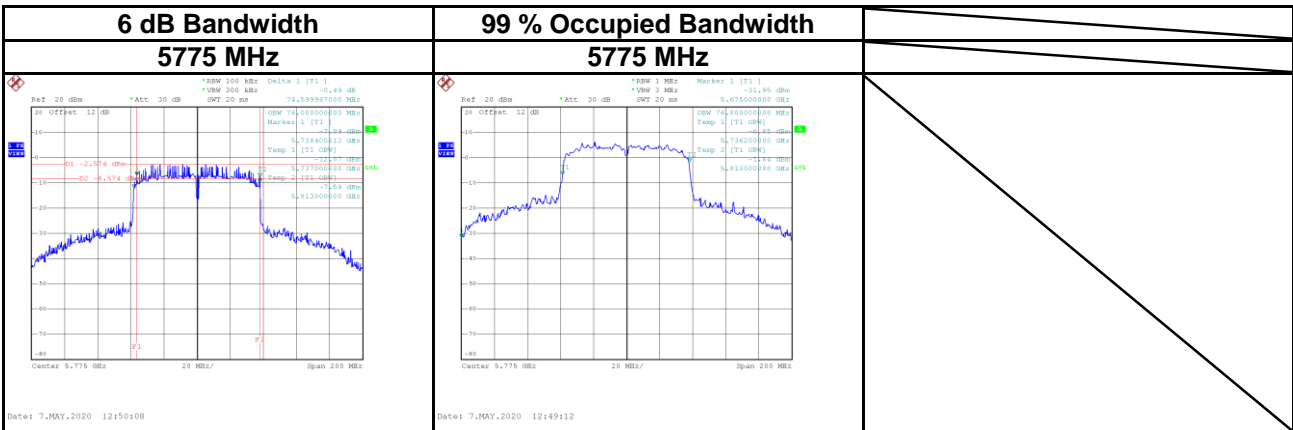

## APPENDIX D CONDUCTED OUTPUT POWER

Test Mode	IEEE 802.11a	Tested Date	2020/5/7
-----------	--------------	-------------	----------

Frequency (MHz)	Conducted Power (dBm)	Conducted Power (W)	Max. Limit (dBm)	Max. Limit (W)	Result
5180	12.21	0.0166	24.00	0.250	Complies
5200	13.56	0.0227	24.00	0.250	Complies
5240	13.36	0.0217	24.00	0.250	Complies

Frequency (MHz)	Conducted Power (dBm)	Conducted Power (W)	Max. Limit (dBm)	Max. Limit (W)	Result
5745	19.16	0.0824	30.00	1.0000	Complies
5785	19.03	0.0800	30.00	1.0000	Complies
5825	19.18	0.0828	30.00	1.0000	Complies

Test Mode	IEEE 802.11n (HT20)	Tested Date	2020/5/7
-----------	---------------------	-------------	----------

Frequency (MHz)	Conducted Power (dBm)	Conducted Power (W)	Max. Limit (dBm)	Max. Limit (W)	Result
5180	12.63	0.0183	24.00	0.250	Complies
5200	13.67	0.0233	24.00	0.250	Complies
5240	13.63	0.0231	24.00	0.250	Complies

Frequency (MHz)	Conducted Power (dBm)	Conducted Power (W)	Max. Limit (dBm)	Max. Limit (W)	Result
5745	19.21	0.0834	30.00	1.0000	Complies
5785	19.22	0.0836	30.00	1.0000	Complies
5825	19.27	0.0845	30.00	1.0000	Complies

Test Mode	IEEE 802.11n (HT40)	Tested Date	2020/5/7
-----------	---------------------	-------------	----------

Frequency (MHz)	Conducted Power (dBm)	Conducted Power (W)	Max. Limit (dBm)	Max. Limit (W)	Result
5190	8.45	0.0070	24.00	0.250	Complies
5230	13.72	0.0236	24.00	0.250	Complies

Frequency (MHz)	Conducted Power (dBm)	Conducted Power (W)	Max. Limit (dBm)	Max. Limit (W)	Result
5755	19.31	0.0853	30.00	1.0000	Complies
5795	19.36	0.0863	30.00	1.0000	Complies

Test Mode	IEEE 802.11ac (VHT20)	Tested Date	2020/5/7
-----------	-----------------------	-------------	----------

Frequency (MHz)	Conducted Power (dBm)	Conducted Power (W)	Max. Limit (dBm)	Max. Limit (W)	Result
5180	12.48	0.0177	24.00	0.250	Complies
5200	13.58	0.0228	24.00	0.250	Complies
5240	13.52	0.0225	24.00	0.250	Complies

Frequency (MHz)	Conducted Power (dBm)	Conducted Power (W)	Max. Limit (dBm)	Max. Limit (W)	Result
5745	18.87	0.0771	30.00	1.0000	Complies
5785	19.17	0.0826	30.00	1.0000	Complies
5825	18.97	0.0789	30.00	1.0000	Complies



Test Mode	IEEE 802.11ac (VHT40)	Tested Date	2020/5/7
-----------	-----------------------	-------------	----------

Frequency (MHz)	Conducted Power (dBm)	Conducted Power (W)	Max. Limit (dBm)	Max. Limit (W)	Result
5190	8.27	0.0067	24.00	0.250	Complies
5230	13.63	0.0231	24.00	0.250	Complies

Frequency (MHz)	Conducted Power (dBm)	Conducted Power (W)	Max. Limit (dBm)	Max. Limit (W)	Result
5755	19.17	0.0826	30.00	1.0000	Complies
5795	19.22	0.0836	30.00	1.0000	Complies

Test Mode	IEEE 802.11ac (VHT80)	Tested Date	2020/5/7
-----------	-----------------------	-------------	----------

Frequency (MHz)	Conducted Power (dBm)	Conducted Power (W)	Max. Limit (dBm)	Max. Limit (W)	Result
5210	8.97	0.0079	24.00	0.250	Complies

Frequency (MHz)	Conducted Power (dBm)	Conducted Power (W)	Max. Limit (dBm)	Max. Limit (W)	Result
5775	19.42	0.0875	30.00	1.0000	Complies

## APPENDIX E POWER SPECTRAL DENSITY

Test Mode	IEEE 802.11a
-----------	--------------

Frequency (MHz)	Power Density (dBm/MHz)	Duty Factor (dB)	Power Density+ Duty Factor (dBm/MHz)	Limit (dBm/MHz)	Result
5180	1.28	0.12	1.40	11.00	Complies
5200	2.18	0.12	2.30	11.00	Complies
5240	2.38	0.12	2.50	11.00	Complies

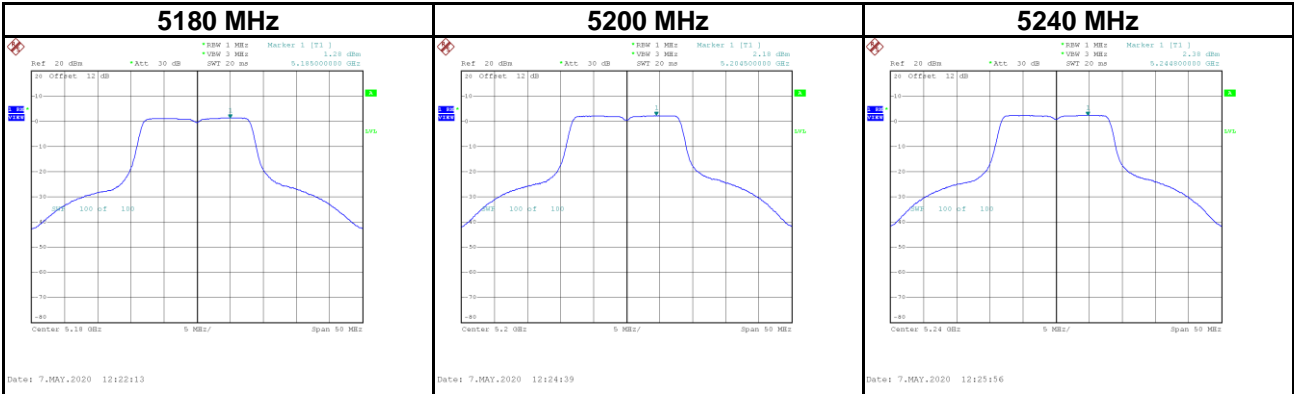

Frequency (MHz)	Power Density (dBm/500KHz)	Duty Factor (dB)	Power Density+ Duty Factor (dBm/500 kHz)	Limit (dBm/500 kHz)	Result
5745	-2.14	0.12	-2.02	30.00	Complies
5785	-2.08	0.12	-1.96	30.00	Complies
5825	-2.41	0.12	-2.29	30.00	Complies

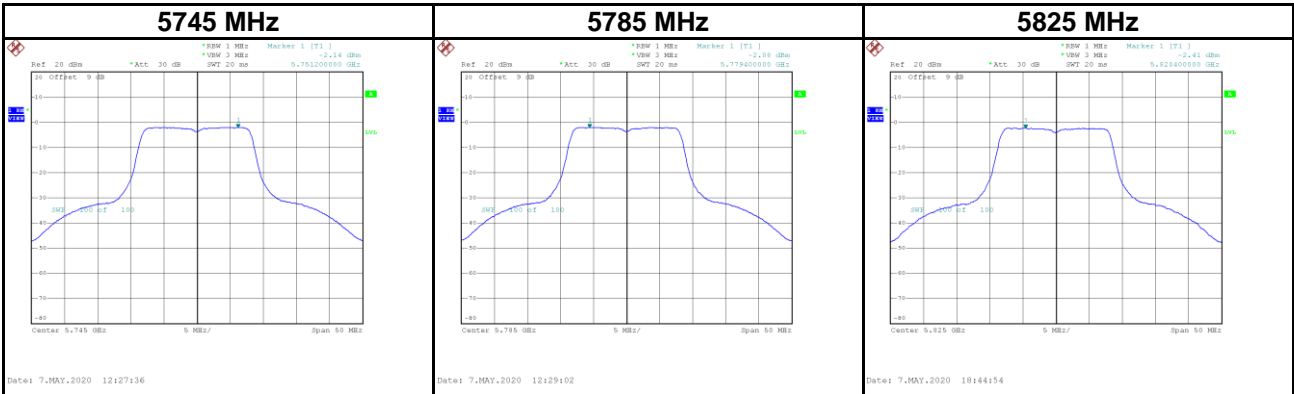

Test Mode	IEEE 802.11n (HT20)
-----------	---------------------

Frequency (MHz)	Power Density (dBm/500 kHz)	Duty Factor (dB)	Power Density+ Duty Factor (dBm/500 kHz)	Limit (dBm/500 kHz)	Result
5180	1.03	0.11	1.14	11.00	Complies
5200	2.08	0.11	2.19	11.00	Complies
5240	2.09	0.11	2.20	11.00	Complies

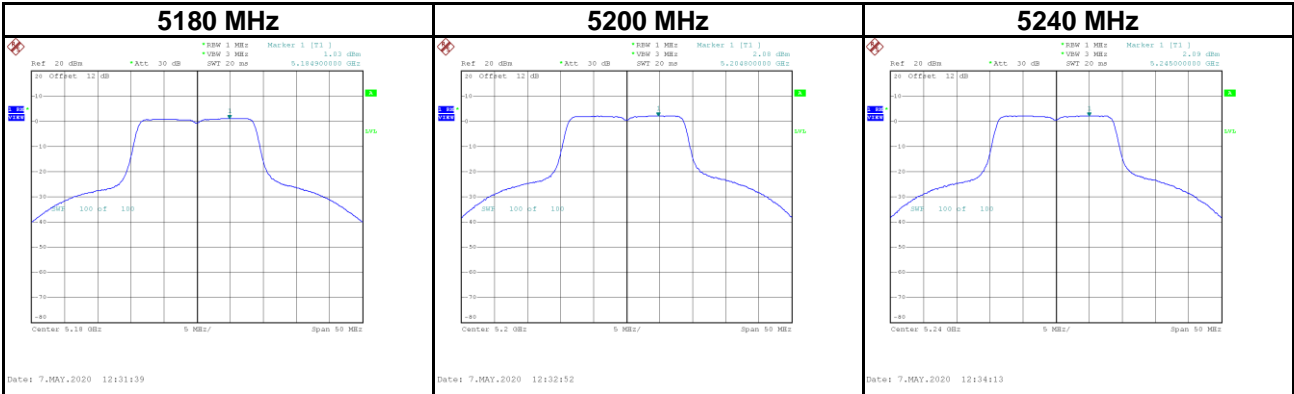

Frequency (MHz)	Power Density (dBm/500kHz)	Duty Factor (dB)	Power Density+ Duty Factor (dBm/500 kHz)	Limit (dBm/500 kHz)	Result
5745	-2.44	0.11	-2.33	30.00	Complies
5785	-2.39	0.11	-2.28	30.00	Complies
5825	-2.55	0.11	-2.44	30.00	Complies

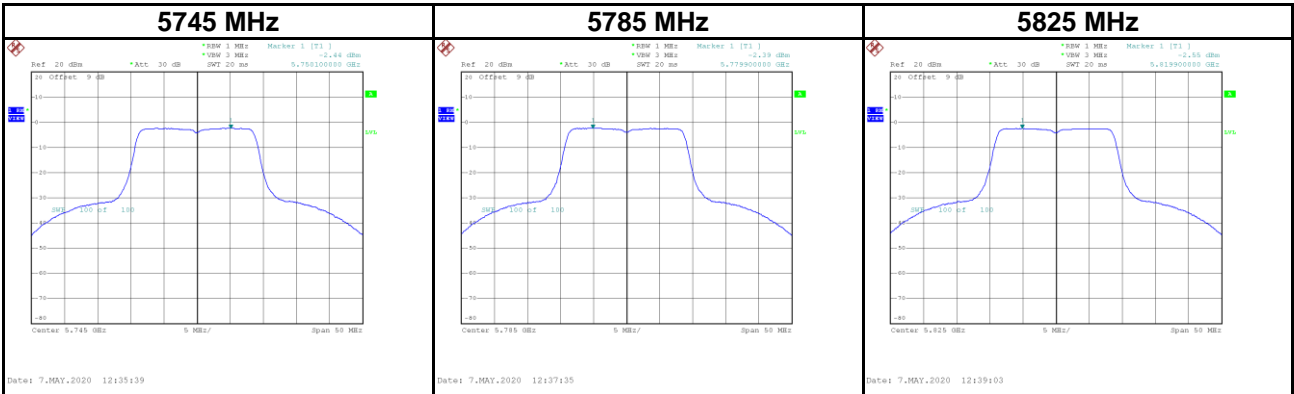

Test Mode	IEEE 802.11n (HT40)
-----------	---------------------

Frequency (MHz)	Power Density (dBm/MHz)	Duty Factor (dB)	Power Density+ Duty Factor (dBm/MHz)	Limit (dBm/MHz)	Result
5190	-5.95	0.51	-5.44	11.00	Complies
5230	-0.66	0.51	-0.15	11.00	Complies

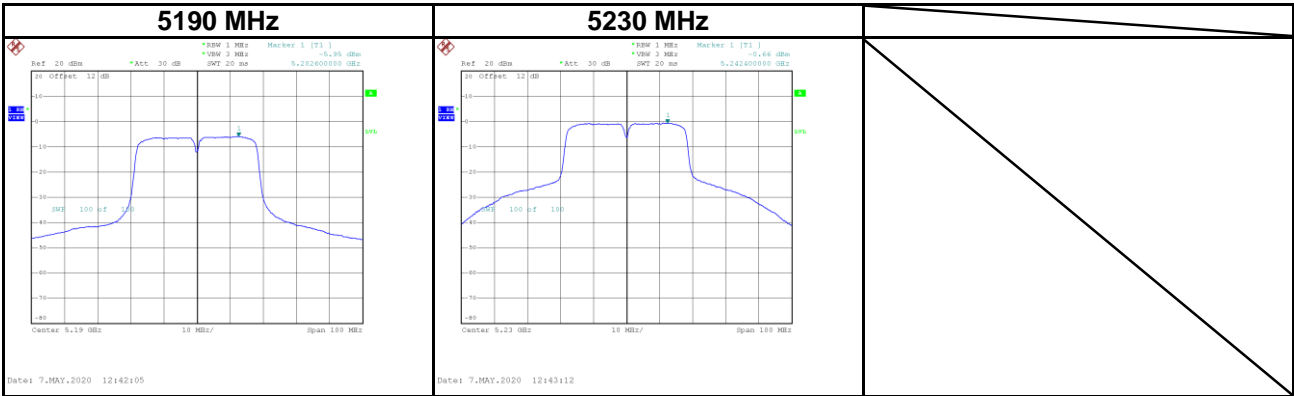

Frequency (MHz)	Power Density (dBm/500KHz)	Duty Factor (dB)	Power Density+ Duty Factor (dBm/500 kHz)	Limit (dBm/500 kHz)	Result
5755	-5.22	0.51	-4.71	30.00	Complies
5795	-5.01	0.51	-4.50	30.00	Complies

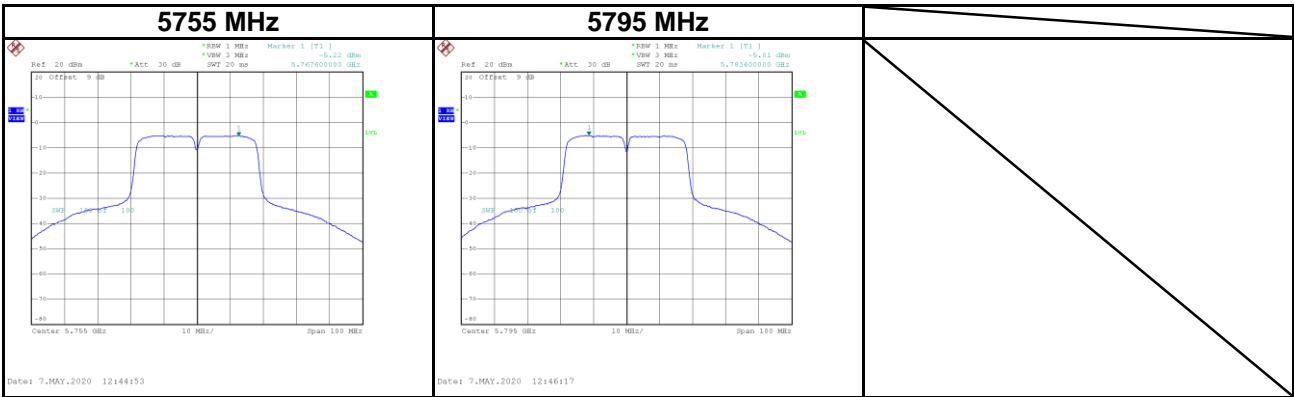

Test Mode	IEEE 802.11ac (VHT80)
-----------	-----------------------

Frequency (MHz)	Power Density (dBm/MHz)	Duty Factor (dB)	Power Density+ Duty Factor (dBm/MHz)	Limit (dBm/MHz)	Result
5210	-9.54	0.99	-8.55	11.00	Complies

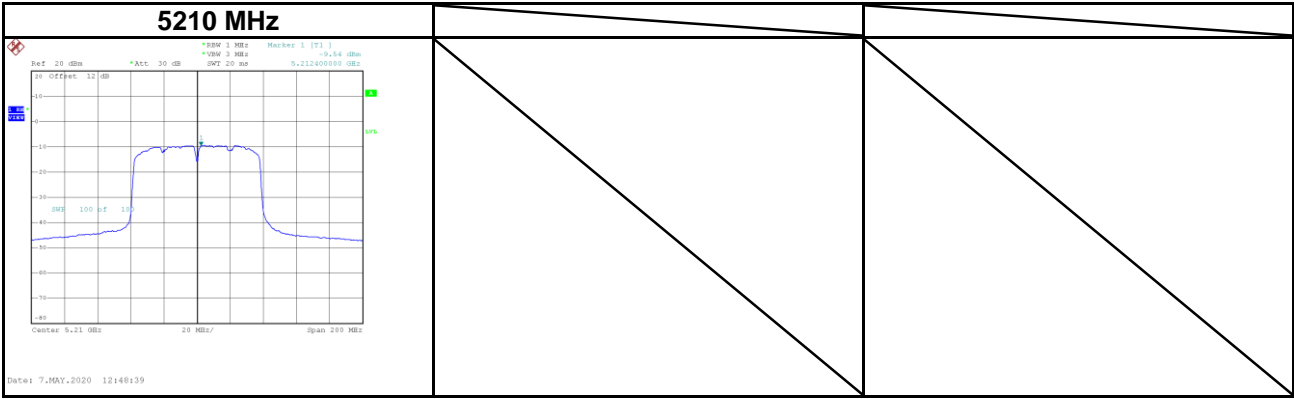

Frequency (MHz)	Power Density (dBm/500KHz)	Duty Factor (dB)	Power Density+ Duty Factor (dBm/500 kHz)	Limit (dBm/500 kHz)	Result
5775	-7.10	0.99	-6.11	30.00	Complies

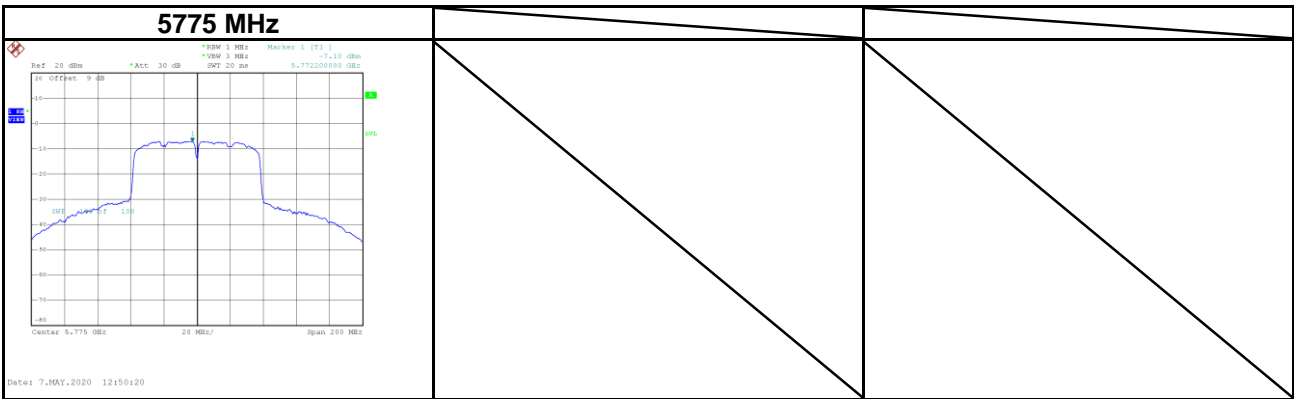

**End of Test Report**