



Test Report

FCC Part 15, Subpart C, Section 15.247 Industry Canada RSS-210, Issue 8

Report Number: HTT-B10EX-Cert

Model: HTT-B10EX

FCC ID: EROHTT-B10EX
IC: 5683C-HTTB10EX

Date: December 5, 2013

Prepared by: Grace Lin Date: Dec. 5, 2013
Grace Lin, Sr. Compliance Engineer

Reviewed by: Wayne Owens Date: Dec. 5, 2013
Wayne Owens, Director of Program Management



Table of Contents

1. GENERAL DESCRIPTION.....	3
1.1 PRODUCT DESCRIPTION	3
1.2 TEST METHODOLOGY	3
1.3 TEST FACILITY.....	3
1.4 TEST EQUIPMENT.....	4
1.5 EVALUATION SUMMARY	4
2. SYSTEM TEST CONFIGURATION.....	5
2.1 JUSTIFICATION	5
2.2 BLOCK DIAGRAM.....	5
2.3 EUT EXERCISE SOFTWARE AND MODE(S) OF OPERATION.....	5
2.4 CABLES.....	5
2.5 SPECIAL ACCESSORIES.....	6
2.6 SUPPORT EQUIPMENT	6
2.7 EQUIPMENT MODIFICATIONS	6
3. EVALUATION	7
3.1 ANTENNA REQUIREMENTS.....	7
3.2 DTS BANDWIDTH	8
3.3 99% BANDWIDTH	11
3.4 POWER OUTPUT	13
3.5 BAND EDGE	16
3.6 CONDUCTED SPURIOUS EMISSIONS	18
3.7 POWER SPECTRAL DENSITY	22
3.8 RADIATED SPURIOUS EMISSIONS	25
3.9 TRANSMITTER AC POWER LINE CONDUCTED EMISSIONS.....	27



1. General Description

1.1 Product Description

The equipment under test (EUT) is a Crestron infiNET™ tabletop controller operating at 2.4 GHz frequency band, model: HTT-B10EX, serial number: CNA8130436.

1.2 Test Methodology

Measurements were performed according to the following procedures and standards:

- 1) ANSI C63.4-2003
- 2) FCC Publication, “Guidance for Performing Compliance Measurements on Digital Transmission Systems (DTS) Operating under §15.247”, April 9, 2013
- 3) Industry Canada RSS-Gen Issue 3
- 4) Industry Canada RSS-210 Issue 8

All measurements were performed in a 3-meter semi-anechoic chamber and the control room.

1.3 Test Facility

The 3-meter semi-anechoic chamber used to collect conducted and radiated emission data is located at 22 Link Drive, Rockleigh, New Jersey. This test facility has been placed on file with the FCC, Registration Number: 412871, and Industry Canada, Site Number: 5683C-1.



1.4 Test Equipment

Description	Model	Serial No.	Frequency Range	Calibration Date
R&S EMI Receiver	ESU40	100076	20 Hz – 40 GHz	Dec. 13, 2012
Teseq Bilog Antenna	CBL 6112D	25231	30 MHz – 2 GHz	Dec. 11, 2012
ETS-Lindgren Double Ridge Horn Antenna	3117	00047560	1 GHz – 18 GHz	Oct. 10, 2013
R&S Preamplifier	TS-PR18	100044	30 MHz – 18 GHz	Dec. 11, 2012
ETS-Lindgren Standard Gain Horn Antenna	3160-09	00078911	18 GHz – 26.5 GHz	Feb. 5, 2013*
R&S Preamplifier	TS-PR26	100030	18 GHz – 26.5 GHz	Dec. 11, 2012

*Mechanical inspection

1.5 Evaluation Summary

Rule Section		Description/Parameters	Results
FCC	IC		
§15.203	N/A	Antenna Requirement	Complies
§15.247(a)(2)	§A8.2(a) of RSS-210	DTS Bandwidth, 500 kHz	Complies
N/A	§4.6.1 of RSS-Gen	99% Occupied Bandwidth	(for reporting purpose)
§15.247(b)(3)	§A8.4(4) of RSS-210	Power Output, conducted, 1 Watt (30dBm)	Complies
§15.247(d)	§2.1, §A8.5 of RSS-210	Band Edge	Complies
§15.247(d)	§A8.5 of RSS-210	Conducted Spurious Emissions, 20 dBc	Complies
§15.247(e)	§A8.2(b) of RSS-210	Power Spectral Density (PSD), 8 dBm in any 3 kHz band.	Complies
§15.205, §15.209, §15.247(d)	§2.2, §A8.5 of RSS-210	Radiated Spurious Emissions	Complies
§15.207	§7.2.4 of RSS-Gen	Transmitter AC Power Line Conducted Emissions	Complies

Note:

The channels selected for test were 11, 18, and 26.

2. System Test Configuration

2.1 Justification

In order to access the test ports, there were two openings made in the plastic enclosure. A computer supplied test commands to the EUT through a test box.

2.2 Block Diagram

Block diagram is shown below.

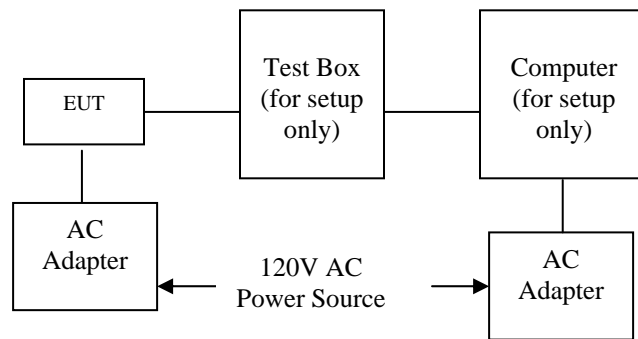

2.3 EUT Exercise Software and Mode(s) of Operation

The EUT was configured to transmit continuously. The firmware loaded were *htt-b10ex_v0.000.0214.ebl*, *htt-b10ex_v0.000.0214.hex*, and *em357-nodetest-with-bootloader.hex*. Channels 11 (2405 MHz), 18 (2440 MHz), and 26 (2480 MHz) were selected for test.

2.4 Cables

Qty	Description	Length (m)	From - To	Shielded/ Unshielded
1	Power Cord	1.8	Power Source – AC Adapter (Computer)	Unshielded
1	USB Cable	2.0	Computer – Test Box	Shielded
1	Ethernet (Crossover)	0.6	Computer – Test Box	Unshielded
1	10-conductor flat	0.3	Test Box – EUT	Unshielded



2.5 *Special Accessories*

There are no special accessories for compliance of this EUT.

2.6 *Support equipment*

Qty	Description	Manufacturer	Model No	Serial No
1	Computer	DELL	PP02X	Service Tag HS5GY61
1	AC Adapter	DELL	LA90PS0-00	CN-0DF266-71615-681-134F
1	Test Box	Ember	ISA3	EM-ISA3-B4A

2.7 *Equipment Modifications*

There were no modifications installed during compliance measurements.



3. Evaluation

3.1 *Antenna Requirements*

This module is validated with a SMD antenna having antenna gain of 2.1 dBi.

The soldering pads of the SMD antenna is unique in the sense of complying with FCC §15.203, §15.204(b), and §15.204(c).



3.2 DTS Bandwidth

Performance Criterion: The minimum DTS bandwidth shall be at least 500 kHz.

Test Results: Complies

Test Details: Refers to the following block diagram, data table, and receiver screen captures. The EUT was tested in a continuous transmit mode at the maximum power levels.

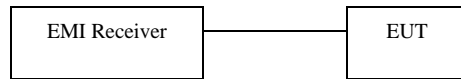

Channel	Frequency (MHz)	DTS Bandwidth (kHz)
11	2405	1594.6
18	2440	1586.5
26	2480	1578.5

Note: The RF level in the plots is relative and is not the indication of RF output power.



DTS Bandwidth, Channel 11:

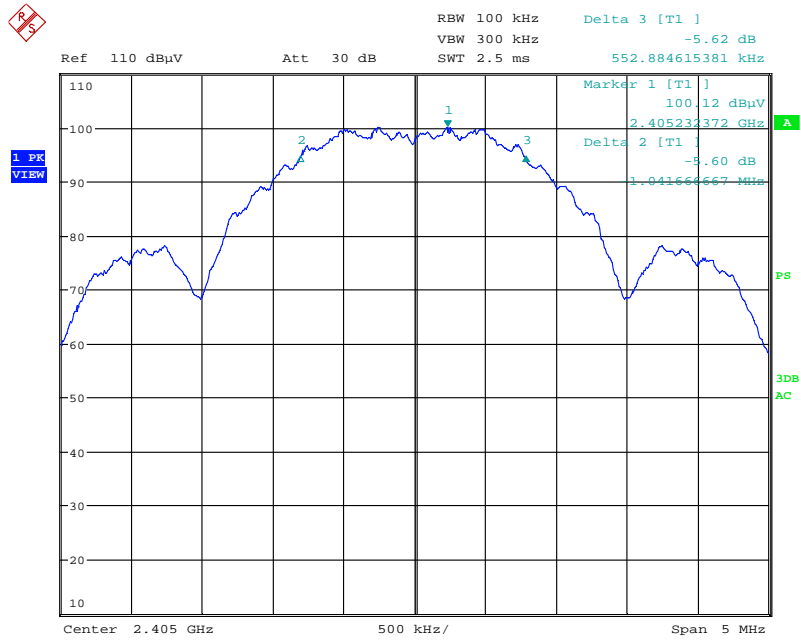

Date: 4.DEC.2013 10:15:26

DTS Bandwidth, Channel 18:

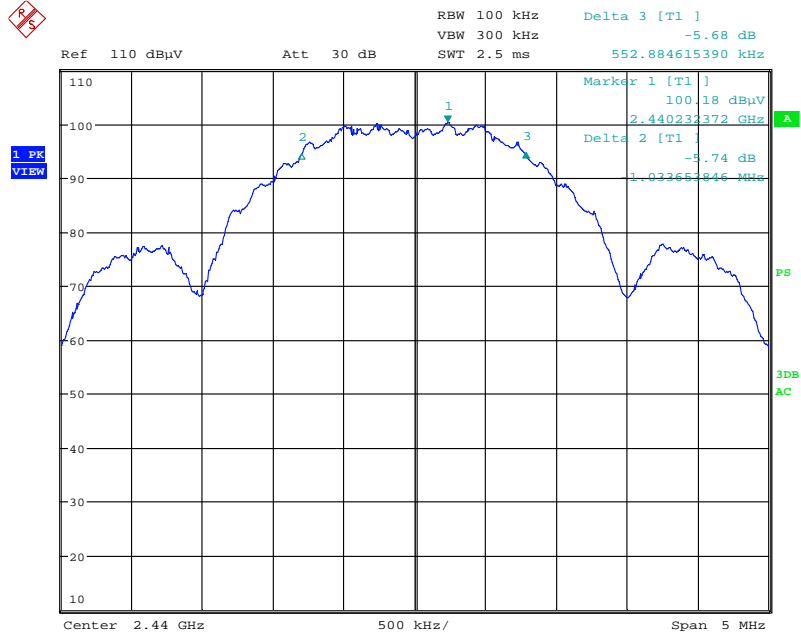

Date: 4.DEC.2013 10:17:59



DTS Bandwidth, Channel 26:

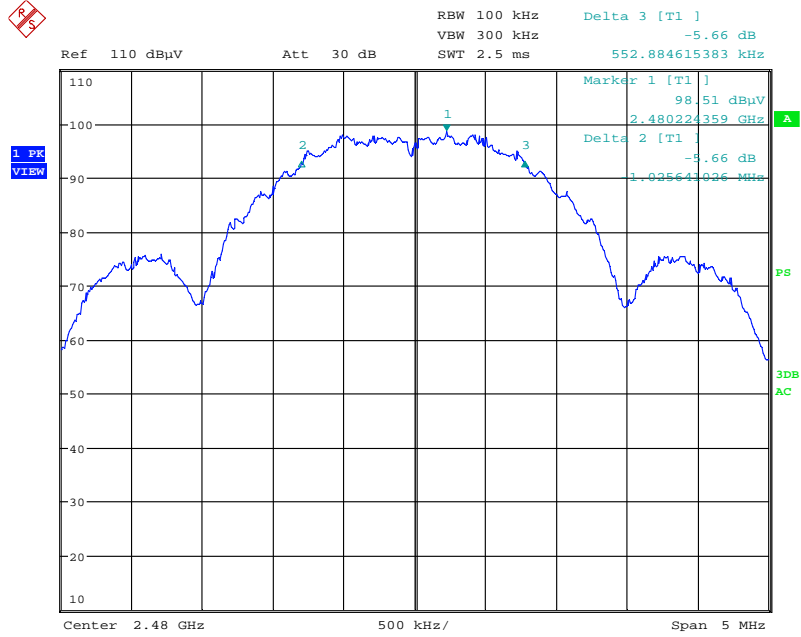

Date: 4.DEC.2013 10:20:01

3.3 99% Bandwidth

Test Details: Refers to the following block diagram, data table, and receiver screen captures. The EUT was tested in a continuous transmit mode at the maximum power levels.

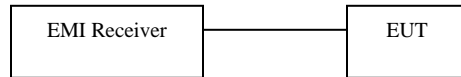

Channel	Frequency (MHz)	99% Bandwidth (MHz)
11	2405	2.468
18	2440	2.468
26	2480	2.452

Note: The RF level in the plots is relative and is not the indication of RF output power.

99% Bandwidth, Channel 11:

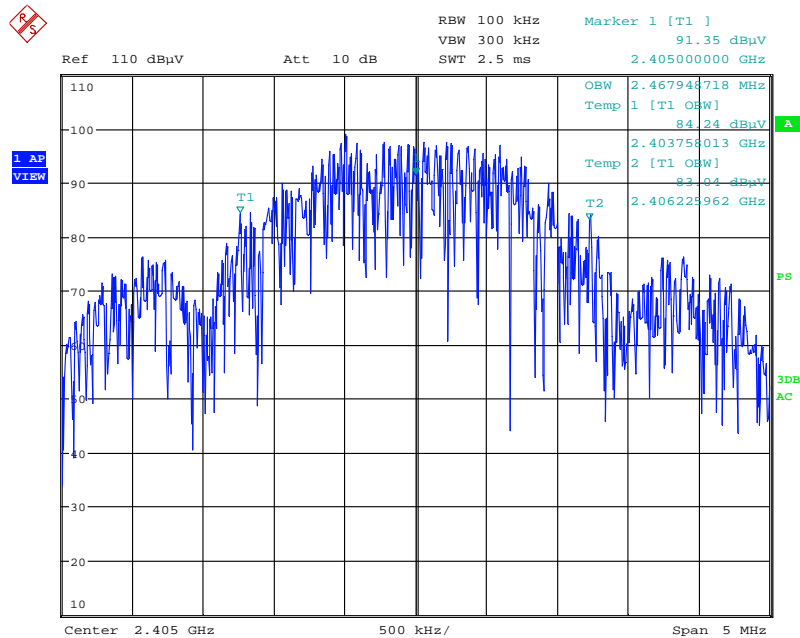

Date: 4.DEC.2013 10:24:53



99% Bandwidth, Channel 18:

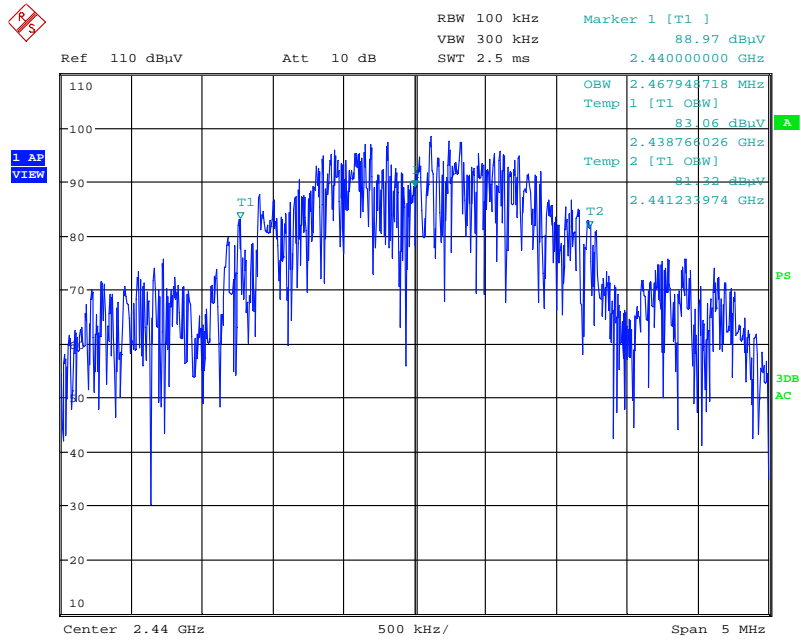

Date: 4.DEC.2013 10:23:34

99% Bandwidth, Channel 26:

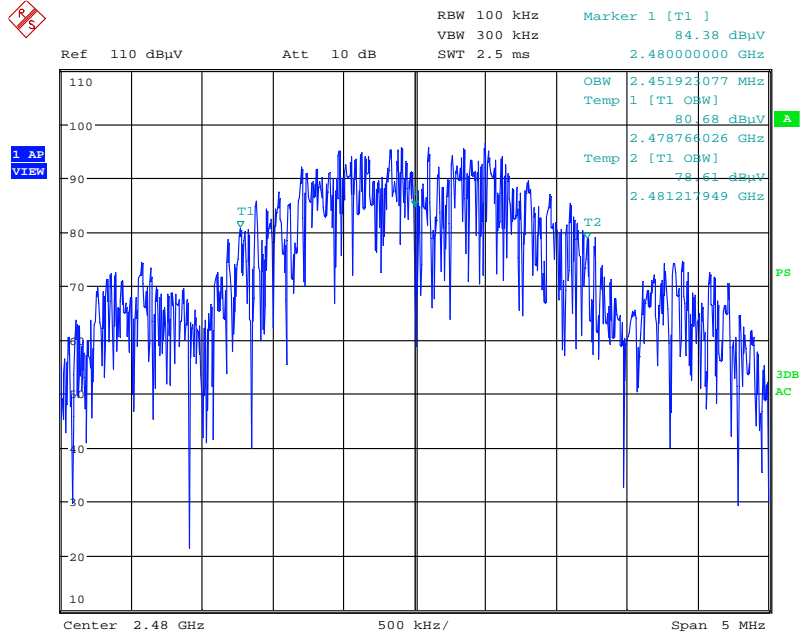

Date: 4.DEC.2013 10:21:54



3.4 Power Output

Performance Criterion: The maximum peak conducted output power shall not exceed 1 Watt.

Test Results: Complies

Test Details: The EUT was tested in a continuous transmit mode with maximum power levels. Refers to the following block diagram, data table, and receiver screen captures.

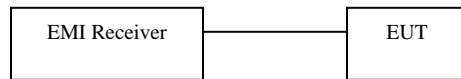

Channel	Frequency (MHz)	Power Level	Power	
			dBm	mW
11	2405	8	7.77	5.9841
18	2440	8	7.69	5.8749
26	2480	6	6.13	4.1020

Note: The insertion loss was compensated for in the receiver.



Power Output, Channel 11:

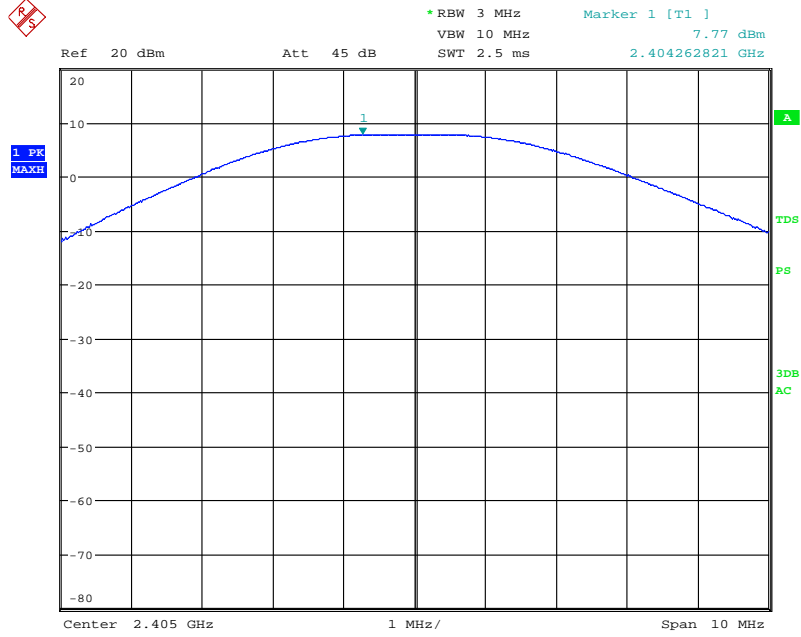

Date: 4.DEC.2013 11:08:22

Power Output, Channel 18:

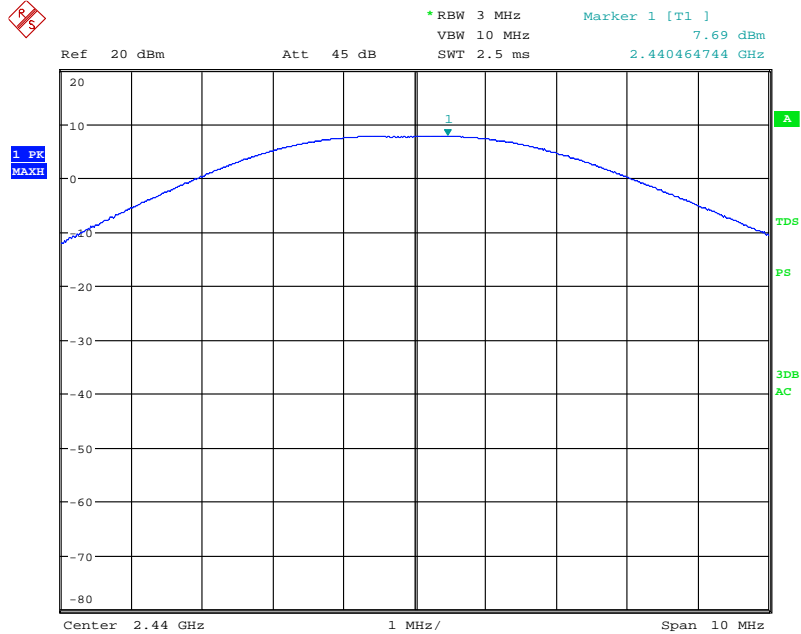

Date: 4.DEC.2013 11:09:43



Power Output, Channel 26:

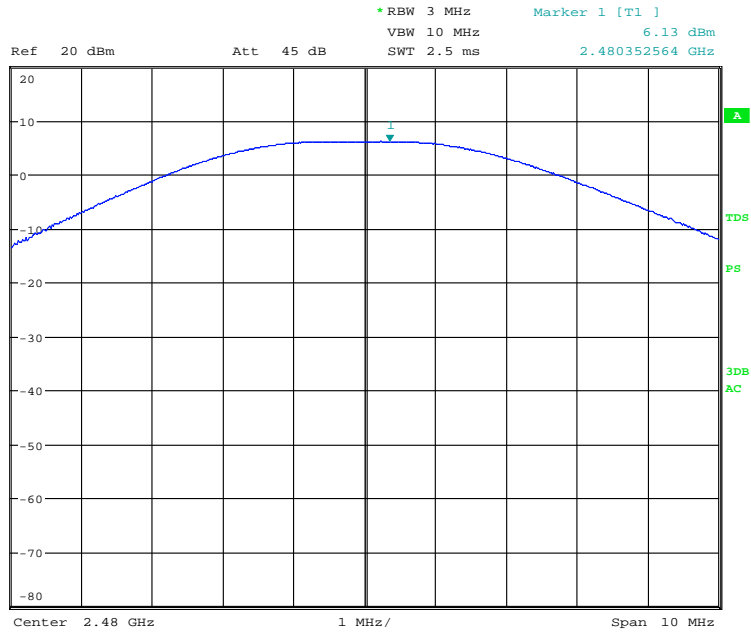

Date: 4.DEC.2013 11:10:54



3.5 *Band Edge*

Performance Criterion: In any 100 kHz bandwidth outside the frequency band, the RF power shall be at least 20 dB below that in the 100 kHz bandwidth within the band.

Test Results: Complies

Test Details: Refers to the following block diagram and receiver screen captures

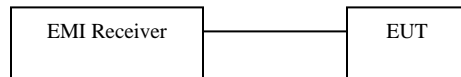



Band Edge:

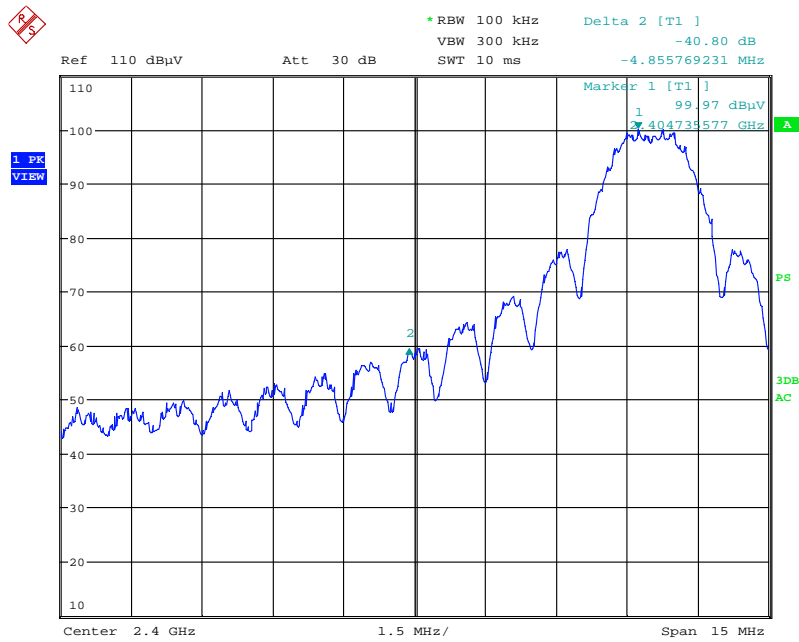

Date: 4.DEC.2013 10:27:25



Date: 4.DEC.2013 10:29:00



3.6 *Conducted Spurious Emissions*

Performance Criterion: In any 100 kHz bandwidth outside the frequency band, the radio frequency power shall be at least 20 dB below that in the 100 kHz bandwidth within the band.

Test Results: Complies

Test Details: Refers to the following block diagram and receiver screen captures

Note: The EUT was tested in a continuous transmit mode at the maximum power levels. The RF level in the screen captures is relative and is not the indication of RF output power.

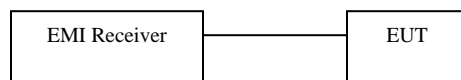



Conducted Spurious Emission – Channel 11

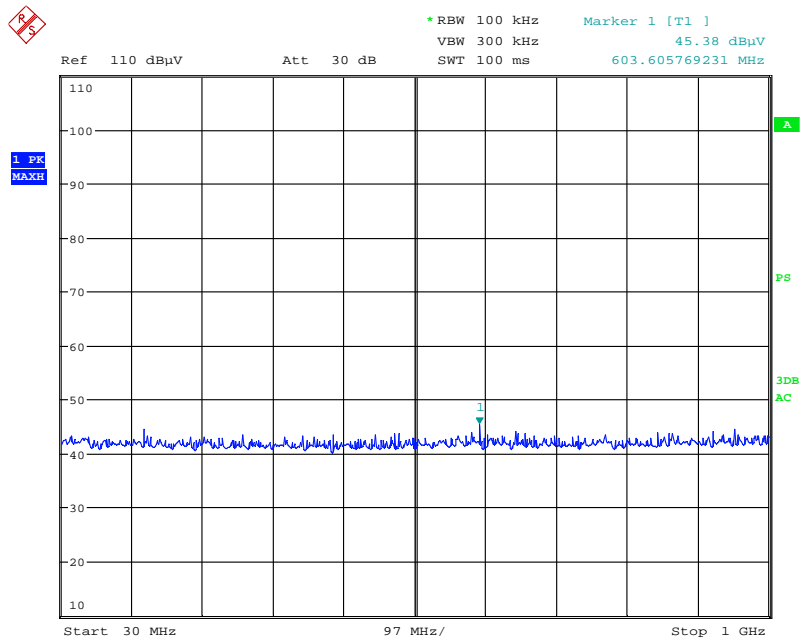

Date: 4.DEC.2013 10:37:55

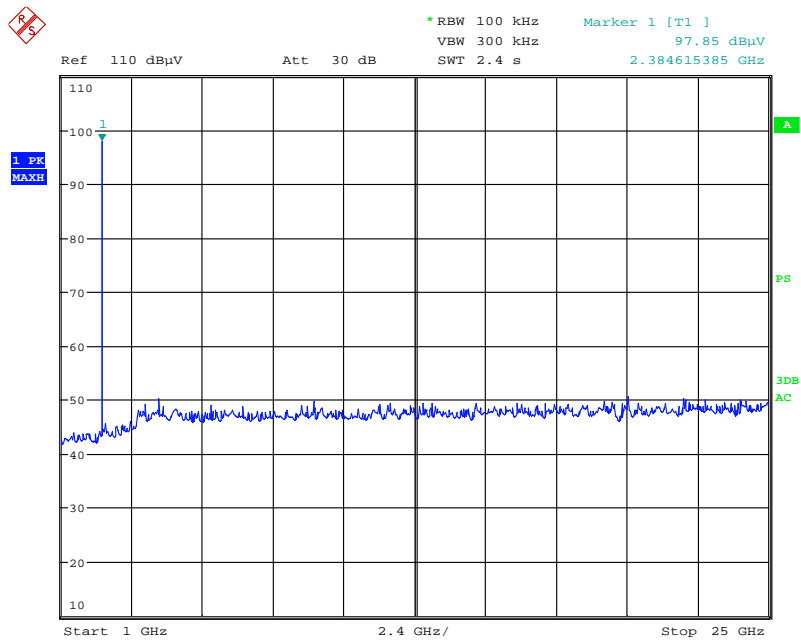

Date: 4.DEC.2013 10:37:25



Conducted Spurious Emission – Channel 18

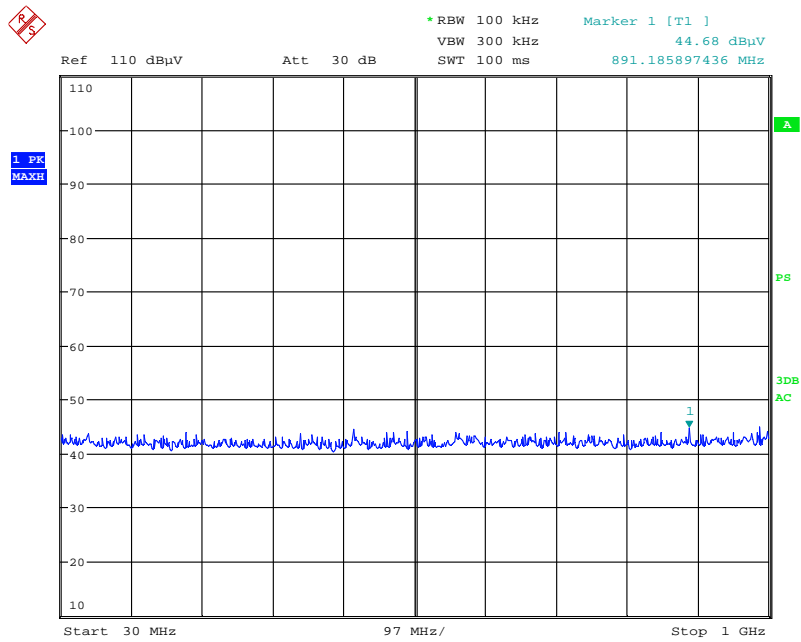

Date: 4.DEC.2013 10:35:09

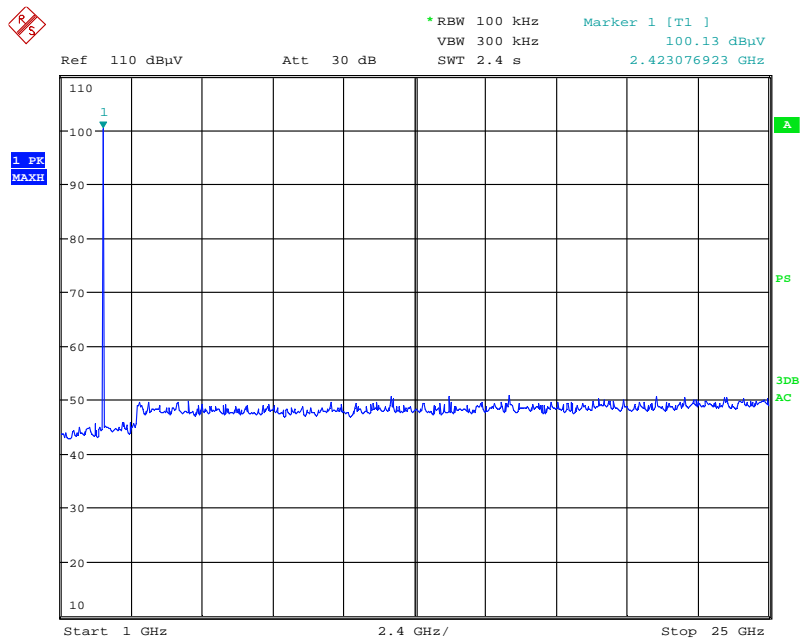

Date: 4.DEC.2013 10:34:29



Conducted Spurious Emission – Channel 26

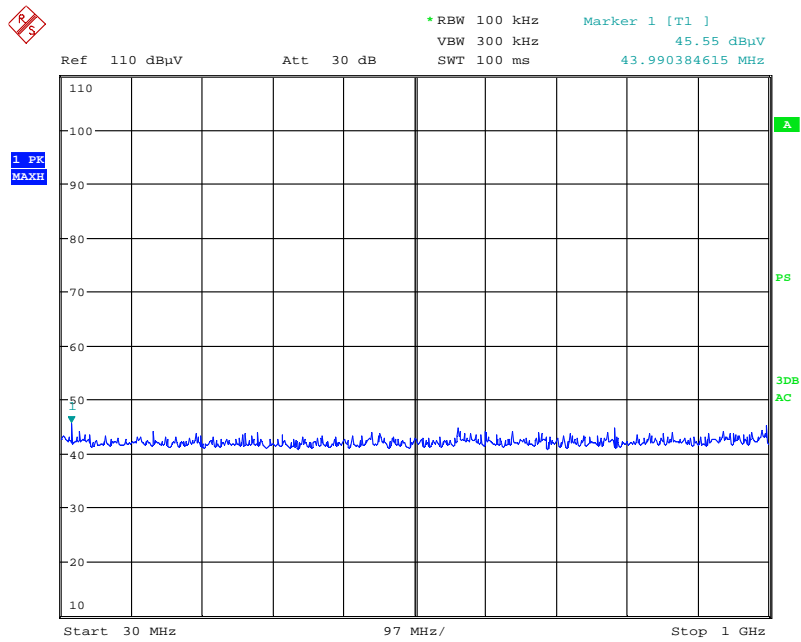

Date: 4.DEC.2013 10:31:13

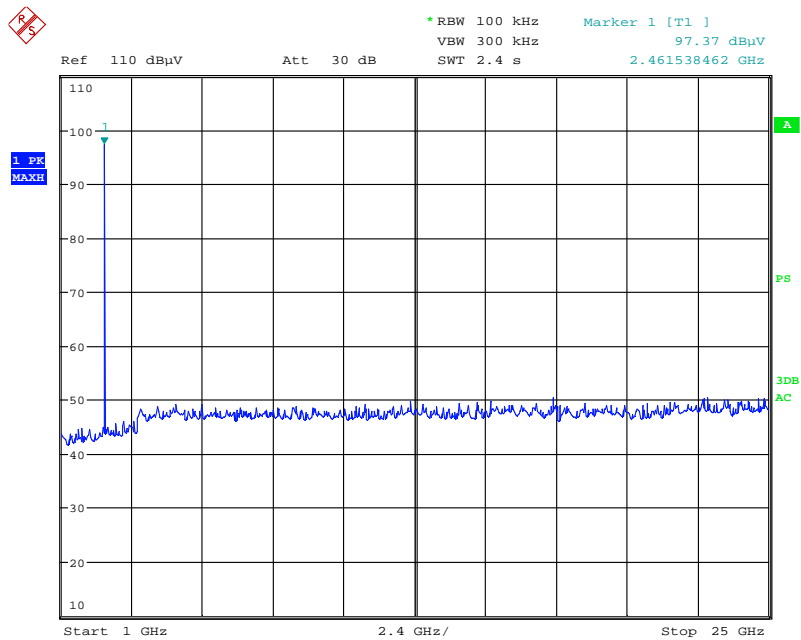

Date: 4.DEC.2013 10:36:22



3.7 Power Spectral Density

Performance Criterion: The power spectral density shall not be greater than 8 dBm in any 3 kHz band.

Test Results: Complies

Test Details: The EUT was tested in a continuous transmit mode with maximum power levels. Refers to the following table and receiver screen captures. The insertion loss was compensated for in the receiver.

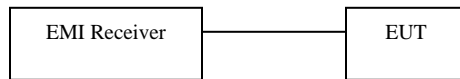

Channel	Frequency (MHz)	Power Spectral Density (dBm)
11	2405	3.96
18	2440	4.08
26	2480	2.47



Power Spectral Density, Channel 11:

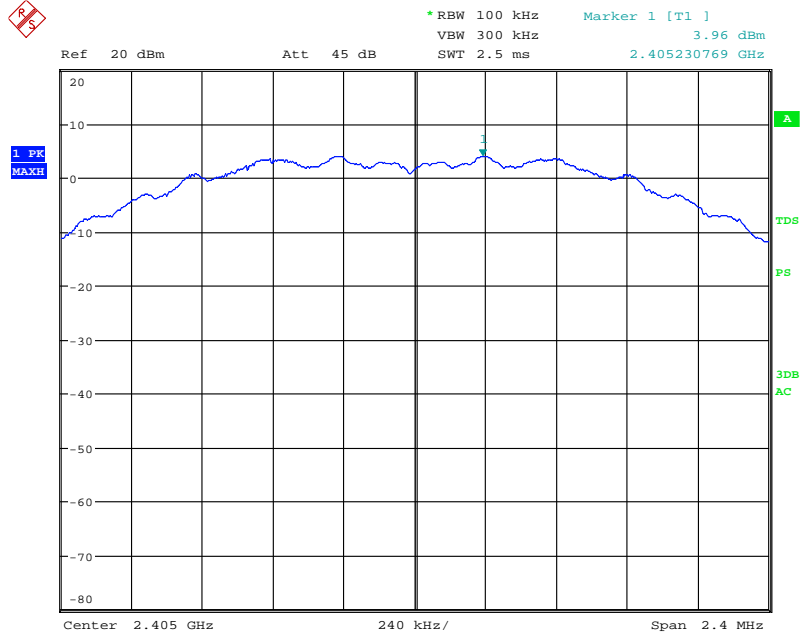

Date: 4.DEC.2013 11:18:27

Power Spectral Density, Channel 18:

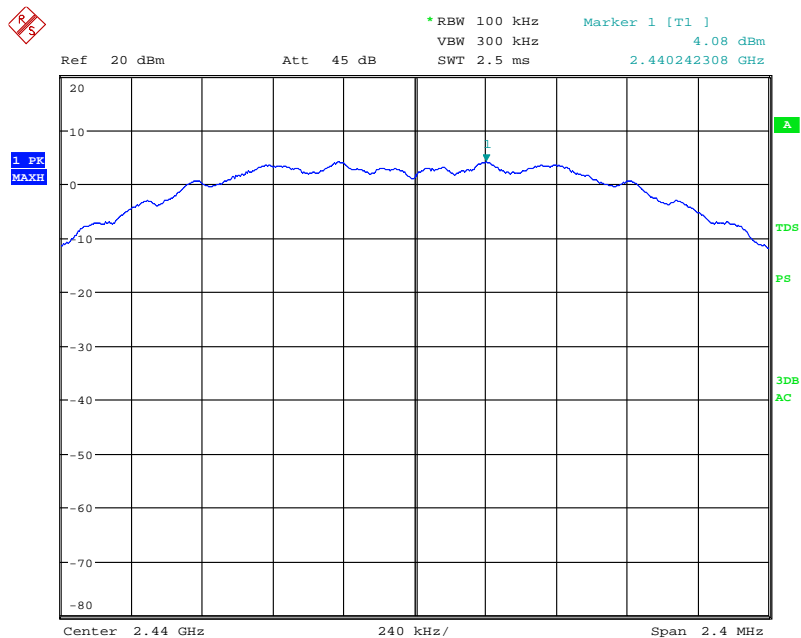

Date: 4.DEC.2013 11:16:25



Power Spectral Density, Channel 26:

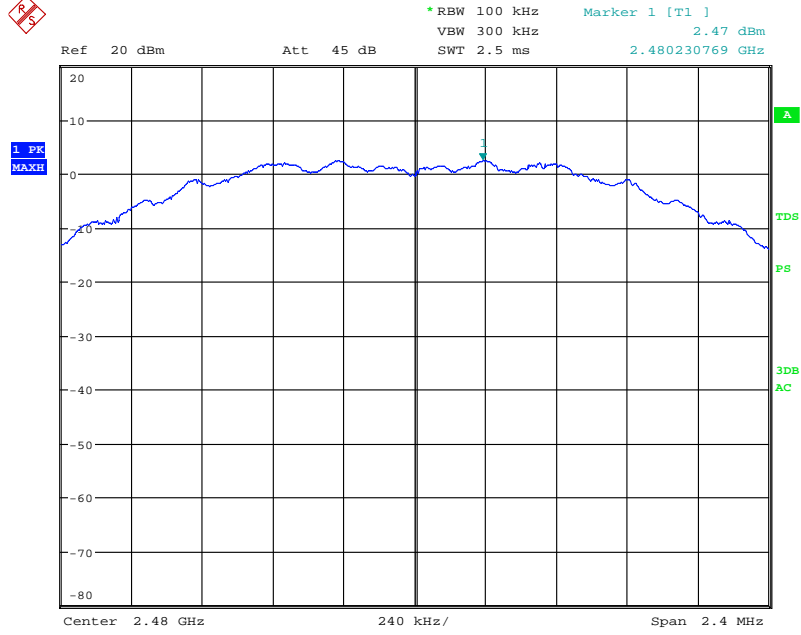

Date: 4.DEC.2013 11:13:06

3.8 Radiated Spurious Emissions

Performance Criterion: Radiated spurious emissions which fall in the restricted bands must comply with the radiated emission limits specified in FCC § 15.209(a) and Table 2 of IC RSS-Gen.

Test Results: Complies

Test Details: Radiated spurious emission was performed from 30 MHz to the tenth harmonics of the carrier. For each scan of radiated emission measurement, the procedures for maximizing emissions were followed. The EUT was rotated and antenna height was varied between 1 m and 4 m in order to maximize the emission. Measurements in both horizontal and vertical polarities were made and the data was recorded. All radiated emission measurements, up to 18 GHz, were performed at 3-meter distance between an antenna and the EUT. All radiated emission measurements, above 18 GHz, were performed at 0.3-meter distance between an antenna and the EUT.

The peak level of radiated emissions above 1 GHz was measured with a resolution bandwidth (RBW) of 1 MHz and a video bandwidth (VBW) of 3 MHz.

For harmonics/spurs that fall in the restricted band, the radiated spurious emissions above 1 GHz were measured with RBW of 1 MHz, VBW of 10 Hz, and Sweep of Auto. The unit was configured for continuous operation.

EUT was tested as tabletop equipment (its intended use).



Refers to the following block diagram and data table for test data. Antenna factor, cable loss, and preamplifier gain were compensated for in the receiver. A factor of 20 dB/decade applies to measurements made at a closer distance than the limit distance before comparing to the limits. Calculation of duty cycle correction factor is included in the Theory of Operation.

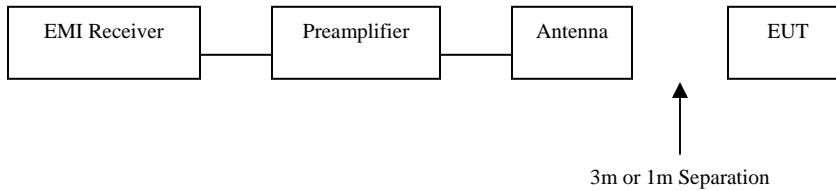

HTT-B10EX Radiated Spurious Emissions											
Antenna Polarization	Frequency (MHz)	Channel No.	Power Setting (Level)	Measured Data (dBuV/m)	Duty Cycle Correction Factor (dB)	Corrected Data	Limit (dBuV/m)	Margin (dB)	Antenna Height (cm)	Turntable Degree	Detector
H	2405	11	8	103.61	-	-	-	-	202.0	359.9	AVE
H	2405	11	8	106.02	-	-	-	-	202.0	359.9	PK
H	2390	11	8	40.30	20.00	20.30	54	33.70	202.0	359.9	AVE
H	2390	11	8	50.74	0.00	50.74	74	23.26	202.0	359.9	PK
H	4810	11	8	40.00	20.00	20.00	54	34.00	162.2	149.6	AVE
H	4810	11	8	51.71	0.00	51.71	74	22.29	162.2	149.6	PK
H	12025 (NF)	11	8	32.36	20.00	12.36	54	41.64	-	-	AVE
H	12025 (NF)	11	8	46.06	0.00	46.06	74	27.94	-	-	PK
H	19240 (NF)*	11	8	24.66	20.00	4.66	54	49.34	-	-	AVE
H	19240 (NF)*	11	8	38.61	0.00	38.61	74	35.39	-	-	PK
H	2440	18	8	104.70	-	-	-	-	195.1	86.8	AVE
H	2440	18	8	106.98	-	-	-	-	195.1	86.8	PK
H	4880	18	8	42.76	20.00	22.76	54	31.24	155.7	125.2	AVE
H	4880	18	8	53.92	0.00	53.92	74	20.08	155.7	125.2	PK
H	7320	18	8	36.37	20.00	16.37	54	37.63	113.4	142.2	AVE
H	7320	18	8	50.93	0.00	50.93	74	23.07	113.4	142.2	PK
H	12200	18	8	38.81	20.00	18.81	54	35.19	114.2	146.2	AVE
H	12200	18	8	52.40	0.00	52.40	74	21.60	114.2	146.2	PK
H	19520 (NF)*	18	8	23.98	20.00	3.98	54	50.02	-	-	AVE
H	19520 (NF)*	18	8	37.34	0.00	37.34	74	36.66	-	-	90.0
H	2480	26	6	99.92	-	-	-	-	193.4	90.2	AVE
H	2480	26	6	102.34	-	-	-	-	193.4	90.2	PK
H	2483.5	26	6	62.94	20.00	42.94	54	11.06	193.4	90.2	AVE
H	2483.5	26	6	72.72	0.00	72.72	74	1.28	193.4	90.2	PK
H	2483.5	25	8	46.52	20.00	26.52	54	27.48	193.4	90.4	AVE
H	2483.5	25	8	59.10	0.00	59.10	74	14.90	193.4	90.4	PK
H	4960	26	6	38.47	20.00	18.47	54	35.53	167.5	116.6	AVE
H	4960	26	6	50.47	0.00	50.47	74	23.53	167.5	116.6	PK
H	7440	26	6	37.93	20.00	17.93	54	36.07	145.6	226.0	AVE
H	7440	26	6	51.19	0.00	51.19	74	22.81	145.6	226.0	PK
H	12400 (NF)	26	6	36.04	20.00	16.04	54	37.96	-	-	AVE
H	12400 (NF)	26	6	48.97	0.00	48.97	74	25.03	-	-	PK
H	19840 (NF)*	26	6	24.10	20.00	4.10	54	49.90	-	-	AVE
H	19840 (NF)*	26	6	37.14	0.00	37.14	74	36.86	-	-	PK
H	22320 (NF)*	26	6	25.11	20.00	5.11	54	48.89	-	-	AVE
H	22320 (NF)*	26	6	38.87	0.00	38.87	74	35.13	-	-	PK

NF: Noise Floor
 *: Tested at 1m

Tested: December 3-4, 2013
 Tested by: Grace Lin



3.9 *Transmitter AC Power Line Conducted Emissions*

Performance Criterion: AC power line conducted emissions shall not exceed the limits specified in FCC § 15.207 and Table 4 of IC RSS-Gen.

Test Results: Complies.

Test Details: AC power line conducted emissions were performed from 150 kHz to 30 MHz and measured with a resolution bandwidth of 9 kHz. EUT was set in the receiving mode. Refers to the following screen captures (using a peak detector) and block diagram.

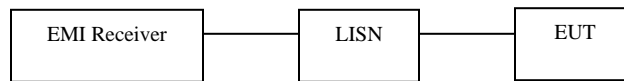

L1:

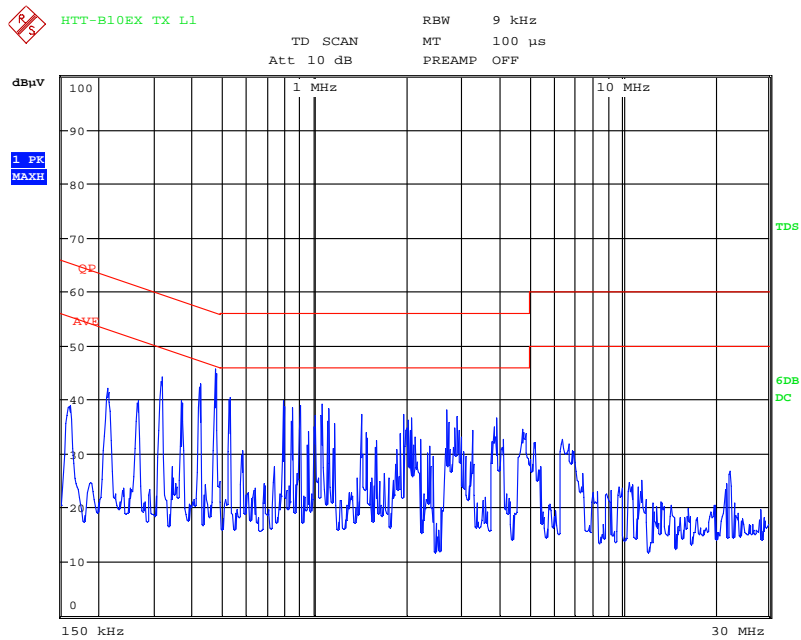

Date: 4.DEC.2013 14:31:32

Conducted Emissions:					
L1, TX:					
Frequency (MHz)	Measured Level (dBuV)		Limit (dBuV)		Margin (dB)
	Quasi-Peak	Average	Quasi-Peak	Average	
0.316	46.2	39.9	59.8	49.8	9.9
0.422	42.3	34.3	57.4	47.4	13.1
0.474	44.8	38.1	56.4	46.4	8.4
0.528	39.0	30.8	56.0	46.0	15.2
0.791	39.3	33.8	56.0	46.0	12.3
1.055	40.8	34.7	56.0	46.0	11.3

Tested by: Grace Lin Date of Test: December 4, 2013

N:

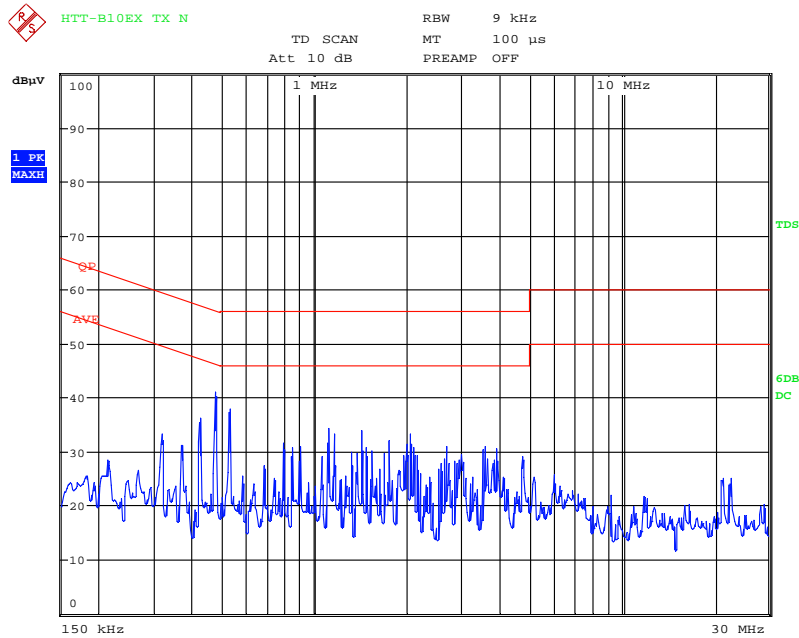

Date: 4.DEC.2013 14:44:17

Conducted Emissions:					
N, TX					
Frequency (MHz)	Measured Level (dBuV)		Limit (dBuV)		Margin (dB)
	Quasi-Peak	Average	Quasi-Peak	Average	
0.316	40.0	36.6	59.8	49.8	13.2
0.422	36.3	32.1	57.4	47.4	15.3
0.474	40.8	35.8	56.4	46.4	10.6
0.528	37.6	29.5	56.0	46.0	16.5
1.106	34.5	30.9	56.0	46.0	15.1
1.424	33.5	27.6	56.0	46.0	18.4

Tested by: Grace Lin Date of Test: December 4, 2013