

REVISIONS				
NAME	REV	DESCRIPTION	DATE	APPROVED
KWC	A	ORIGINAL ISSUE PER EWO2049	02/17/15	

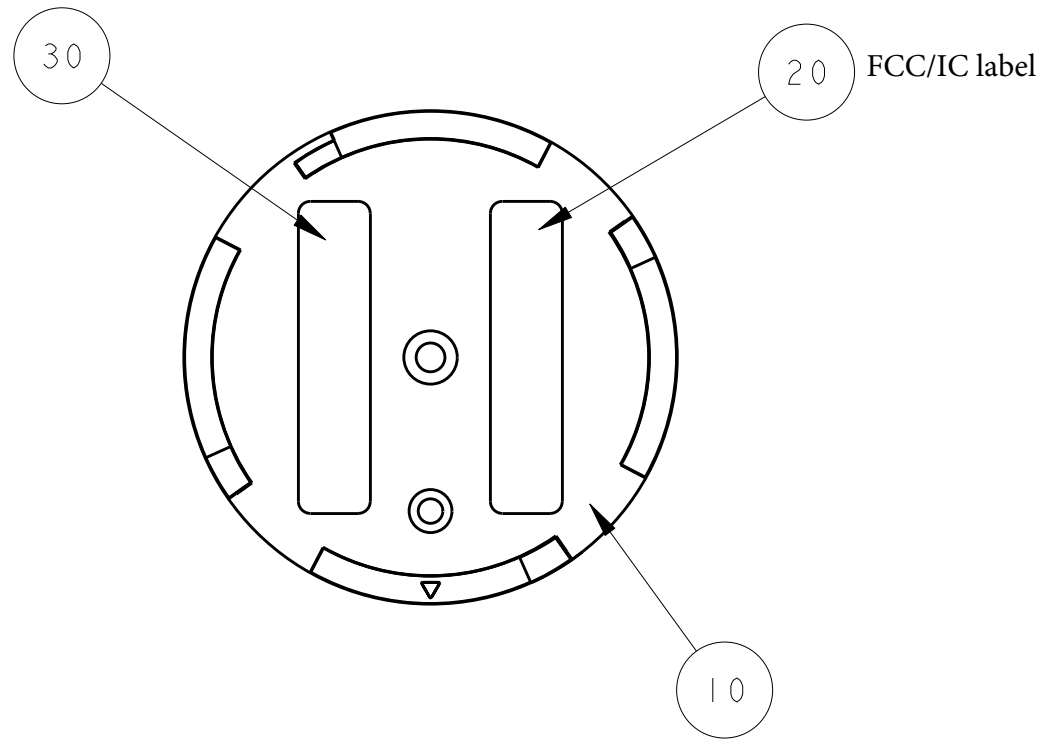

THIS DRAWING IS THE EXCLUSIVE PROPERTY OF CRESTRON ELECTRONICS, INC. DISCLOSURE OR REPRODUCTION IN WHOLE OR PART, WITHOUT PRIOR WRITTEN PERMISSION, IS PROHIBITED EXCEPT FOR THE MANUFACTURE OF THE ARTICLES FOR CRESTRON.

UNLESS OTHERWISE SPECIFIED:
 ALL DIMENSIONS ARE IN INCHES
 TOLERANCES ARE:
 FRACTIONS ±1/64 ANGLES ±1/2°
 DECIMALS .X±.1 .XX±.01 .XXX±.005



ALL PARTS & PROCESSES MUST
 BE RoHS COMPLIANT
 DEBURR AND BREAK ALL SHARP
 EDGES

ASSY, MOUNTING BASE WITH
 BARCODE

		DESIGN BY	KWC	02/15/17			
6507060	GLS-LDL-EX-BATT	DRAWN BY	KWC	02/17/15	SIZE	PRINT NUMBER	REV
FINISHED GOODS	SORT NAME	CHECKED			A	170422	A
USED ON (FOR INTERNAL USE ONLY)		APPROVED	BR	02/15/17	SCALE: 1:1	FILE: 170422	SHEET 1 OF 1