

Crestron **ZUMMESH NETBRIDGE**
Wireless Room System Network Bridge

Installation & Operations Guide



Regulatory Compliance

[UL Compliance Underway]

Federal Communications Commission (FCC) Compliance Statement

This device complies with Part 15 of the FCC Rules. Operation is subject to the following two conditions: (1) This device may not cause harmful interference, and (2) This device must accept any interference received, including interference that may cause undesired operation. CAUTION: Changes or modifications not expressly approved by the manufacturer responsible for compliance could void the user's authority to operate the equipment.

NOTE: This equipment has been tested and found to comply with the limits for a Class B digital device, pursuant to part 15 of the FCC Rules. These limits are designed to provide reasonable protection against harmful interference in a residential installation. This equipment generates, uses and can radiate radio frequency energy and if not installed and used in accordance with the instructions, may cause harmful interference to radio communications. However, there is no guarantee that interference will not occur in a particular installation. If this equipment does cause harmful interference to radio or television reception, which can be determined by turning the equipment off and on, the user is encouraged to try to correct the interference by one or more of the following measures:

- Reorient or relocate the receiving antenna
- Increase separation between the equipment and the receiver
- Connect the equipment into an outlet on a circuit different from that to which the receiver is connected
- Consult the dealer or an experienced radio/TV technician for help

This equipment complies with FCC radiation exposure limits set forth for an uncontrolled environment. This equipment should be installed and operated with minimum distance 20cm between the radiator and your body. This transmitter must not be co-located or operating in conjunction with any other antenna or transmitter.

Industry Canada (IC) Compliance Statement

Operation is subject to the following two conditions:

- This device may not cause interference, and
- This device may accept any interference, including interference that may cause undesired operation of the device.

This equipment complies with IC RSS-102 radiation exposure limits set forth for an uncontrolled environment. This equipment should be installed and operated with minimum distance 20cm between the radiator and your body.

Cet équipement est conforme aux limites d'exposition aux radiations IC CNR-102 établies pour un environnement non contrôlé. Cet équipement doit être installé et utilisé avec une distance minimale de 20 cm entre le radiateur et votre corps.

Description

The Crestron® ZUMMESH NETBRIDGE is designed for the Wireless Room System to be monitored and controlled from a centralized Crestron Control System. The Network Bridge plugs into any J-Box Wireless Room System device and wirelessly communicates to a Crestron CEN-GWEXER Gateway.

The Network Bridge provides basic information to the Crestron Gateway regarding room status, devices within the room etc. The Network Bridge also includes a BlueTooth LE connection allowing system setup via a smart phone. The Network Bridge is a low voltage device, powered from the Expansion Port on the J-Box device.

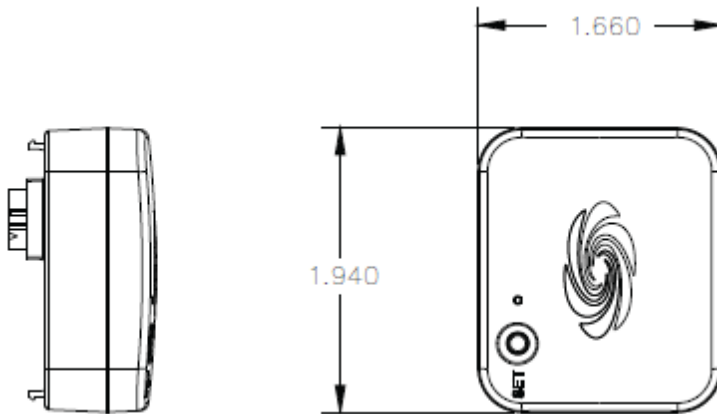

Specifications

Specification	Detail
Power Requirements	5V, 280mA
Environmental Temperature Humidity	32° to 104°F (0° to 40°C) 10% to 90% RH (non-condensing)
Enclosure	UL 5VA plastic
Mounting	Attaches to any ZUMMESH J-Box Load Controller model: <ul style="list-style-type: none">- GL-WRS-DIMFLV*- GL-WRS-HSW*- GL-WRS-PWS*

Installation

WARNING: To avoid fire, shock, or death, turn off power at circuit breaker or fuse before installing!

NOTES: Observe the following points.

- Codes: Install in accordance with all local and national electrical codes.
- Temperature: For use where temperatures are between 32° to 104°F (0° to 40°C).

Install the ZUMMESH NETBRIDGE

1. Turn the power off at the circuit breaker.
2. Remove cover from J-Box device
3. Plug in ZUMMESH NETBRIDGE
4. Restore power at the circuit breaker.

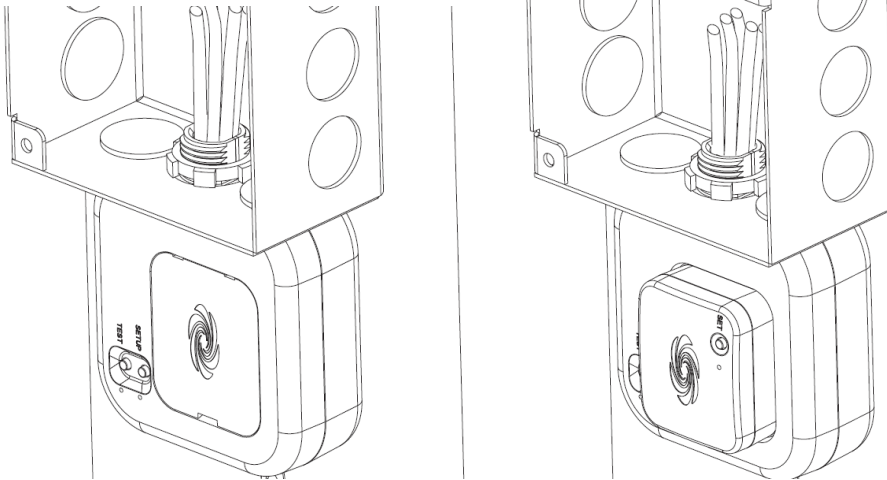

Wireless Communication

The device connects to the wireless room system via physical connection to the J-Box device. The Network Bridge connects to the Crestron ZUMMESH Gateway using Crestron ZUMMESH protocol. Use the procedures outlined below to join or leave the Crestron ZUMMESH Network.

Joining a Crestron EX Network

1. Place Gateway into Acquire mode – see Gateway Instruction manual.
2. Tap the SET button 4 times in quick succession, holding for at least 2 seconds on the fourth press (hold for 10 seconds if device is already part of a network).
3. Release the button once the LED lights.
4. The LED will blink slowly while searching for a network and light solid once connected to the ZUMMESH Network.

Troubleshooting

The following table provides corrective action for possible trouble situations. If further assistance is required, please contact a Crestron customer service representative.

GL-WRS-KP1/2-HA Troubleshooting

TROUBLE	PROBABLE CAUSE(S)	CORRECTIVE ACTION
TBD		

Return and Warranty Policies

Merchandise Returns / Repair Service

1. No merchandise may be returned for credit, exchange or service without prior authorization from CRESTRON. To obtain warranty service for CRESTRON products, contact an authorized CRESTRON dealer. Only authorized CRESTRON dealers may contact the factory and request an RMA (Return Merchandise Authorization) number. Enclose a note specifying the nature of the problem, name and phone number of contact person, RMA number and return address.

2. Products may be returned for credit, exchange or service with a CRESTRON Return Merchandise Authorization (RMA) number. Authorized returns must be shipped freight prepaid to CRESTRON, 6 Volvo Drive, Rockleigh, N.J. or its authorized subsidiaries, with RMA number clearly marked on the outside of all cartons. Shipments arriving freight collect or without an RMA number shall be subject to refusal. CRESTRON reserves the right in its sole and absolute discretion to charge a 15% restocking fee plus shipping costs on any products returned with an RMA.

3. Return freight charges following repair of items under warranty shall be paid by CRESTRON, shipping by standard ground carrier. In the event repairs are found to be nonwarranty, return freight costs shall be paid by the purchaser. CRESTRON Limited Warranty

CRESTRON ELECTRONICS, Inc. warrants its products to be free from manufacturing defects in materials and workmanship under normal use for a period of three (3) years from the date of purchase from CRESTRON, with the following exceptions: disk drives and any other moving or rotating mechanical parts, pan/tilt heads and power supplies are covered for a period of one (1) year; touchscreen display and overlay components are covered for 90 days; batteries and incandescent lamps are not covered.

This warranty extends to products purchased directly from CRESTRON or an authorized CRESTRON dealer. Purchasers should inquire of the dealer regarding the nature and extent of the dealer's warranty, if any. CRESTRON shall not be liable to honor the terms of this warranty if the product has been used in any application other than that for which it was intended or if it has been subjected to misuse, accidental damage, modification or improper installation procedures. Furthermore, this warranty does not cover any product that has had the serial number altered, defaced or removed.

This warranty shall be the sole and exclusive remedy to the original purchaser. In no event shall CRESTRON be liable for incidental or consequential damages of any kind (property or economic damages inclusive) arising from the sale or use of this equipment. CRESTRON is not liable for any claim made by a third party or made by the purchaser for a third party. CRESTRON shall, at its option, repair or replace any product found defective, without charge for parts or labor. Repaired or replaced equipment and parts supplied under this warranty shall be covered only by the unexpired portion of the warranty.

Except as expressly set forth in this warranty, CRESTRON makes no other warranties, expressed or implied, nor authorizes any other party to offer any warranty, including any implied warranties of merchantability or fitness for a particular purpose. Any implied warranties that may be imposed by law are limited to the terms of this limited warranty. This warranty statement supersedes all previous warranties.