

Crestron **CWD6609**

Two-Way RF Transceiver Module

---

Operations Guide



**CRESTRON**

This document was prepared and written by the Technical Documentation department at:



Crestron Electronics, Inc.

15 Volvo Drive

Rockleigh, NJ 07647

1-888-CRESTRON

# Contents

<b>Two-Way RF Transceiver Module: CWD6609 .....</b>	<b>1</b>
Introduction .....	1
Functions and Features .....	1
Specifications .....	2
Physical Description .....	2
Industry Compliance .....	4
Setup .....	6
Hardware Hookup .....	6
End Product Labeling .....	7
Documentation .....	7



# Two-Way RF Transceiver Module: CWD6609

---

## Introduction

### Functions and Features

The CWD6609 (hereafter referred to as “module”) is a two-way radio frequency (RF) module that utilizes the 2.4 GHz frequency band to communicate with other devices.

The module operates according to the IEEE 802.15.4 specification and can be configured to minimize the possibility of interference with other devices.

The module receives RF signals from one or more Crestron devices and can transmit these signals over the air or over a cable run for further processing (depending on the application).

#### *Functional Summary*

- Two-way RF transceiver
  - 2.4 GHz frequency band, IEEE 802.15.4 specification
  - Range from 3 feet to 50 ft.
  - Operates on one of sixteen available channels to establish optimal signal quality

The transceiver uses a 1.67 milliwatt signal that can travel up to approximately 50 feet indoors. The range is dependent on the construction of the building, obstructions, and RF interference from other devices. The location of the module and the orientation of its antenna are also important factors in determining RF performance.

## Specifications

The table below is a summary of specifications for the CWD6609.

### *Specifications of the CWD6609*

SPECIFICATION	DETAILS
Power Requirements	0.58 Watts (5.0VDC @ 0.115A)
Operating Frequency	2400 MHz to 2483.5 MHz (802.15.4 compliant)
Operating Ranges <sup>1</sup>	
Minimum Distance	3 ft
Maximum Distance Indoors (without repeater device)	50 ft
Available Channels	16 (numbered 11 through 26 per 802.15.4)
RF Output Power	1.67 mW
Dimensions	Width: 1.64 in (4.15 cm) Height: 2.35 in (5.98 cm) Depth: 0.66 in (1.68 cm)

- The location and the orientation of the module are important factors in the RF performance. The range is dependent on its placement and the building in which it is used. The construction of the building, obstructions, and RF interference from other devices are factors determining the effective range of the unit. To prevent unit-to-unit RF interference, multiple modules operating at the same frequencies should not be installed within 3-5 feet of each other.

## Physical Description

The module, shown below, consists of various components attached to a printed circuit board. A circuit-board mounted antenna is located at the top of the board while a 10-pin connector for the application-specific installation is located at the bottom of the board.

### *Physical View of CWD6609*

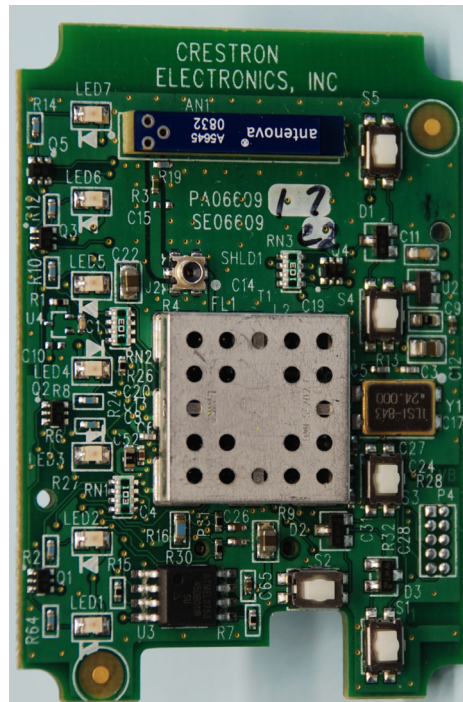

*CWD6609 Detail Views*

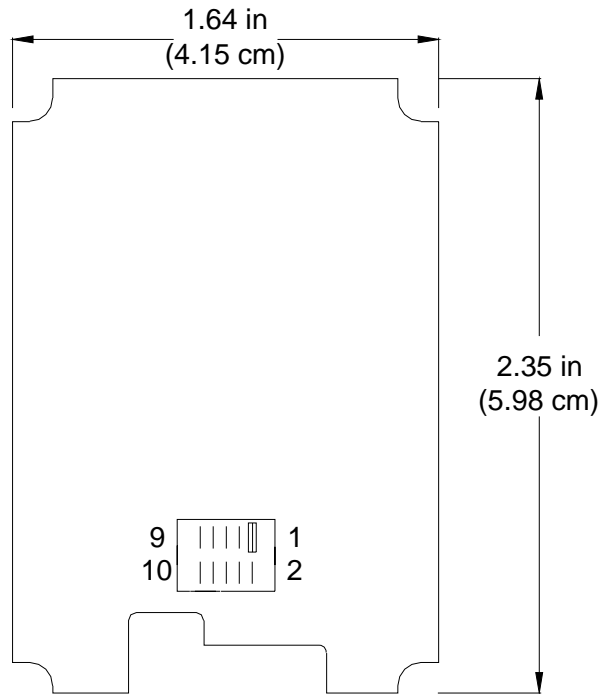

**Ports**

The module contains a 10-pin connector. Refer to the diagram and description that follow.

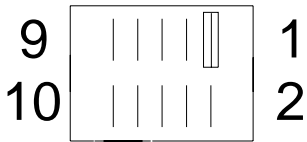

**Power/I-O**

The 10-pin connector provides power to the module as well as communications between the module and wired devices. Refer to the following table for pin assignments of the module interface connector.

---

**NOTE:** Pin 1 provides power to the circuit card.

---

*Power/I-O Pinout Signals*

Pin #	Signal	Pin #	Signal
1	+5V	6	REMOTE_B/CONFIG
2	TRIAC/RELAY	7	GND
3	ZERO_X	8	3.3v
4	REMOTE_A/RELAY	9	GND
5	GND	10	GND

## Industry Compliance

### Labeling Requirements

If the FCC ID on the CWD6609 is not visible when the module is installed inside another device, then the outside of the device into which the module is installed must also display a label referring to the enclosed module. This exterior label can use wording such as the following: "Contains Transmitter Module FCC ID: EROCWD6609" or "Contains FCC ID: EROCWD6609." Any similar wording that expresses the same meaning may be used.

### Compliance Statement (Part 15.19 )

This device complies with Part 15 of the FCC Rules. Operation is subject to the following two conditions:

1. This device may not cause harmful interference, and
2. This device must accept any interference received, including interference that may cause undesired operation.

### Warning (Part 15.21 )

Changes or modifications not expressly approved by the party responsible for compliance could void the user's authority to operate the equipment.

### RF Exposure (OET Bulletin 65 )

To comply with FCC RF exposure requirements for mobile transmitting devices, this transmitter should only be used or installed at locations where there is at least 20cm separation distance between the antenna and all persons.

### Industry Canada Statement

The term "IC" before the certification/registration number only signifies that the Industry Canada technical specifications were met.  
IC: 5683C-CWD6609

### Section 7.1.5 of RSS-GEN

Operation is subject to the following two conditions:

- 1) this device may not cause interference, and
- 2) this device must accept any interference, including interference that may cause undesired operation of the device.

### FCC Radiation Exposure Statement:

This equipment complies with FCC radiation exposure limits set forth for an uncontrolled environment. This equipment should be installed and operated with minimum distance 20cm between the radiator & your body. This transmitter must not be co-located or operating in conjunction with any other antenna or transmitter.

This device is intended only for OEM integrators under the following conditions:

1. The antenna must be installed such that 20 cm is maintained between the antenna and users, and
2. The transmitter module may not be co-located with any other transmitter or antenna.

As long as the two conditions above are met, further transmitter test will not be required. However, the OEM integrator is still responsible for testing their end-product for any additional compliance requirements required with this module installed (for example, digital device emissions, PC peripheral requirements, etc.).



---

**IMPORTANT NOTE:** In the event that these conditions cannot be met (for example certain laptop configurations or co-location with another transmitter), then the FCC authorization is no longer considered valid and the FCC ID cannot be used on the final product. In these circumstances, the OEM integrator will be responsible for reevaluating the end product (including the transmitter) and obtaining a separate FCC authorization.

---

---

## Setup

### Hardware Hookup

Refer to the hookup diagram below, which shows the connections made to the module. Complete the connections in any order.

---

**NOTE:** To prevent unit-to-unit RF interference, multiple modules operating at the same frequencies should not be installed within three to five feet of each other.

---

#### *Hookup Connections for CWD6609*

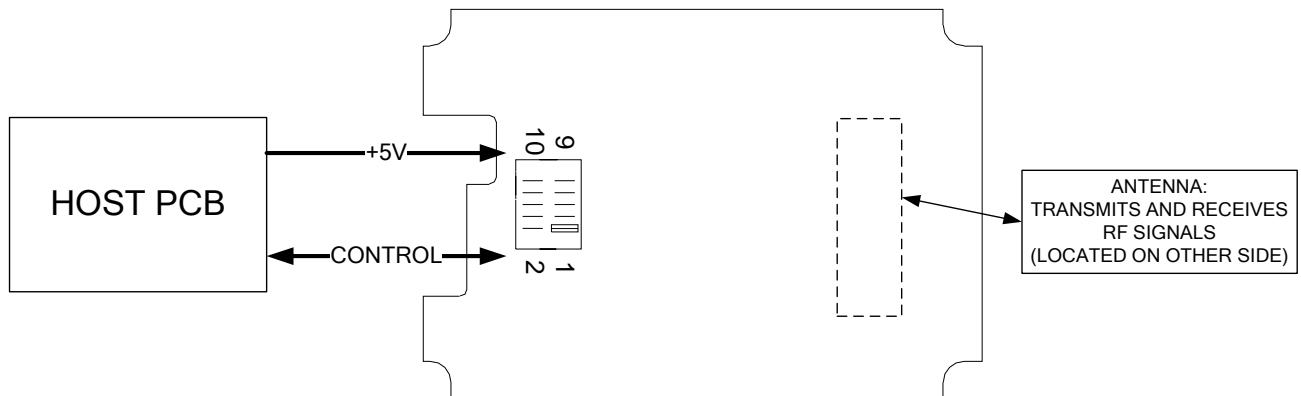

For more information on these connectors, refer to "Ports" on page 3.

## End Product Labeling

The final end product must be labeled in a visible area with the following: “Contains FCC ID: EROCWD6609 .

## Documentation

The OEM integrator has to be aware not to provide information to the end user regarding how to install or remove this RF module in the users manual of the end product which integrate this module.

The users manual for OEM integrators must include the following information in a prominent location

**“IMPORTANT NOTE:** To comply with FCC RF exposure compliance requirements, the antenna used for this transmitter must be installed to provide a separation distance of at least 20 cm from all persons and must not be co-located or operating in conjunction with any other antenna or transmitter.”

