



Test Report

FCC Part 15, Subpart C, Section 15.247

Report Number: CENRFGWEX2-FCC

Model: CENRFGWEX2

FCC ID: EROCENRFGWEXPWE

Date: July 22, 2010 (Revised August 19, 2010)

Prepared by: Grace Lin
Grace Lin, Sr. Compliance Engineer

Date: July 22, 2010

Reviewed by: Wayne Owens
Wayne Owens, Director of Program Management

Date: July 22, 2010



Table of Contents

1. GENERAL DESCRIPTION	3
1.1 PRODUCT DESCRIPTION	3
1.2 TEST METHODOLOGY	3
1.3 TEST FACILITY.....	3
1.4 TEST EQUIPMENT.....	4
1.5 EVALUATION SUMMARY	4
2. SYSTEM TEST CONFIGURATION	5
2.1 JUSTIFICATION	5
2.2 BLOCK DIAGRAM.....	5
2.3 EUT EXERCISE SOFTWARE AND MODE(S) OF OPERATION	5
2.4 CABLES.....	6
2.5 SPECIAL ACCESSORIES.....	6
2.6 SUPPORT EQUIPMENT	6
2.7 EQUIPMENT MODIFICATIONS	6
3. EVALUATION	7
3.1 ANTENNA REQUIREMENTS.....	7
3.2 6 dB BANDWIDTH	8
3.3 POWER OUTPUT	11
3.4 BAND EDGE	14
3.5 CONDUCTED SPURIOUS EMISSIONS	16
3.6 POWER SPECTRAL DENSITY	20
3.7 RADIATED SPURIOUS EMISSIONS	23
3.8 TRANSMITTER AC POWER LINE CONDUCTED EMISSIONS.....	25
3.9 RECEIVER RADIATED EMISSIONS	27
3.10 RECEIVER AC POWER LINE CONDUCTED EMISSIONS	29



1. General Description

1.1 Product Description

The equipment under test (EUT) is a Crestron infiNET EX™ Wireless Gateway, trade name: CEN-RFGW-EX, model: CENRFGWEX2. There is two package options: CEN-RFGW-EX and CEN-RFGW-EX-PWE. CEN-RFGW-EX-PWE contains a CEN-RFGW-EX and a PoE injector.

1.2 Test Methodology

Measurements were performed according to the following procedures and standards:

- 1) ANSI C63.4: 2003
- 2) FCC Procedure, "Measurement of Digital Transmission Systems Operating under Section 15.247", March 23, 2005
- 3) Industry Canada RSS-Gen Issue 2
- 4) Industry Canada RSS-210 Issue 7
- 5) Industry Canada ICES-003 Issue 4

All measurements were performed in a 3-meter semi-anechoic chamber and the control room.

1.3 Test Facility

The 3-meter semi-anechoic chamber used to collect conducted and radiated emission data is located at 22 Link Drive, Rockleigh, New Jersey. This test facility has been placed on file with the FCC, Registration Number: 412871, and Industry Canada, Site Number: 5683C-1.



1.4 Test Equipment

Description	Model	Serial No.	Frequency Range	Calibration Date
R&S EMI Receiver	ESU40	100076	20 Hz – 40 GHz	Dec. 22, 2009
Teseq Bilog Antenna	CBL 6112D	25231	30 MHz – 2 GHz	Jan. 28, 2010
ETS-Lindgren Double Ridge Horn Antenna	3117	00047560	1 GHz – 18 GHz	Jan. 27, 2010
R&S Preamplifier	TS-PR18	100044	30 MHz – 18 GHz	Feb. 9, 2010
ETS-Lindgren Standard Gain Horn Antenna	3160-09	00078911	18 GHz – 26.5 GHz	May 10, 2010*
R&S Preamplifier	TS-PR26	100030	18 GHz – 26.5 GHz	Feb. 23, 2010
Solar Electronics LISN	9252-50-R-24-N	068546	10 kHz – 50 MHz	Feb. 3, 2010

* Visual inspection

1.5 Evaluation Summary

Rule Section		Description/Parameters	Results
FCC	IC		
§15.203	N/A	Antenna Requirement	Complies
§15.247(a)(2)	§A8.2(a) of RSS-210	6 dB Bandwidth, 500 kHz	Complies
§15.247(b)(3)	§A8.4(4) of RSS-210	Power Output, conducted, 1 Watt (30dBm)	Complies
§15.247(d)	§2.1, §A8.5 of RSS-210	Band Edge	Complies
§15.247(d)	§A8.5 of RSS-210	Conducted Spurious Emissions, 20 dBc	Complies
§15.247(e)	§A8.2(b) of RSS-210	Power Spectral Density (PSD), 8 dBm in any 3 kHz band.	Complies
§15.205, §15.209, §15.247(d)	§2.2, §2.7, §A8.5 of RSS-210	Radiated Spurious Emissions	Complies
§15.207	§7.2.2 of RSS-Gen	Transmitter AC Power Line Conducted Emissions	Complies
§15.101(b)	§6 of RSS-Gen	Receiver Radiated Emission	Complies
§15.107	§7.2.2 of RSS-Gen	Receiver AC Power Line Conducted Emissions	Complies

Note:

The channels selected for test were 11, 18, and 26.

2. System Test Configuration

2.1 Justification

EUT was powered through the LAN PoE or Cresnet port. A computer supplied test commands.

2.2 Block Diagram

Block diagram is shown below.

LAN PoE Port:

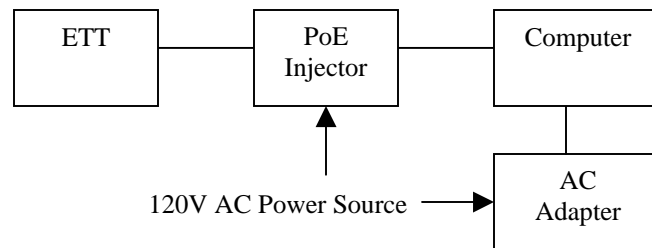

Cresnet Port:

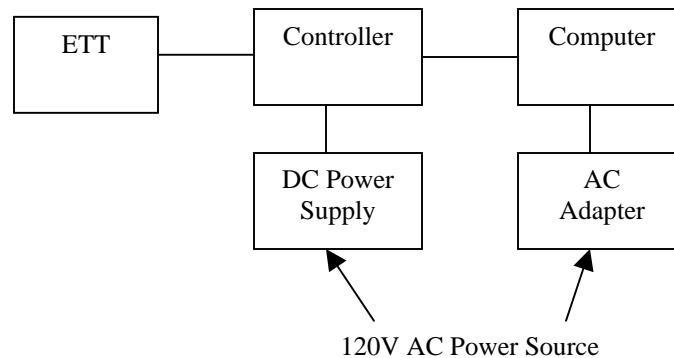

2.3 EUT Exercise Software and Mode(s) of Operation

The EUT was configured to transmit continuously. Channels 11 (2405 MHz), 18 (2440 MHz), and 26 (2480 MHz) were selected for test.



2.4 Cables

Qty	Description	Length (m)	From - To	Shielded/ Unshielded
1	Power Cord	1.5	Power Source – PoE Injector	Unshielded
1	Cat 6 (crossover)	0.6 or 12	Computer – PoE Injector	Unshielded
1	Cat 5E	1.5	EUT – PoE Injector	Unshielded
1	Cresnet	15	EUT – Controller	Unshielded
1	Cresnet	1.3	DC Power Supply – Controller	Shielded
1	RS232	1 or 8.5	Computer – Controller	Shielded

2.5 Special Accessories

There are no special accessories for compliance of this EUT.

2.6 Support equipment

No	Description	Manufacturer	Model No	Serial No
1	Computer	DELL	PP02X	38707541497
2	AC Power Adapter	DELL	LA90PS0-00	CN-0DF266-71615-681-134F
3	DC Power Supply	BK Precision	1670	281-2152
4	Controller	Crestron	QM-RMCRX-BA	3123167
5	Hub	D-Link	DE805TP	AC789A2698
6	AC Power Adapter	Coby	CA-979	Not Labeled

2.7 Equipment Modifications

There were no modifications installed during compliance measurements.



3. Evaluation

3.1 *Antenna Requirements*

This module is validated with a dipole antenna. Antenna gain of the dipole antenna is $2\text{dBi} \pm 0.5\text{dB}$.

The reverse polarity SMA (RP-SMA) connector of the dipole antenna is unique in the sense of complying with FCC §15.203, §15.204(b), and §15.204(c).



3.2 6 dB Bandwidth

Performance Criterion: The minimum 6 dB bandwidth shall be at least 500 kHz.

Test Results: Complies

Test Details: Refers to the following block diagram, data table, and receiver screen captures. The EUT was tested in a continuous transmit mode with maximum power levels at boost mode.

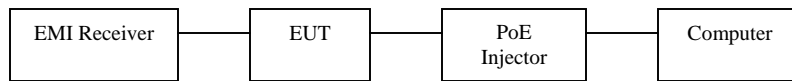

Channel	Frequency (MHz)	6 dB Bandwidth (kHz)
11	2405	1618.6
18	2440	1642.2
26	2480	1554.5

Note: The RF level in the plots is relative and is not the indication of RF output power.



6 dB Bandwidth, Channel 11:

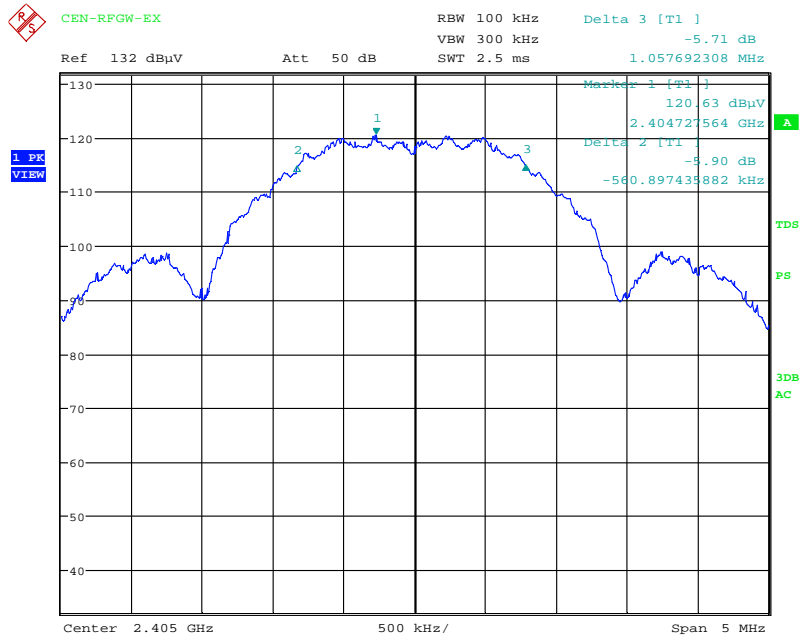

Date: 22.JUL.2010 10:54:49

6 dB Bandwidth, Channel 18:

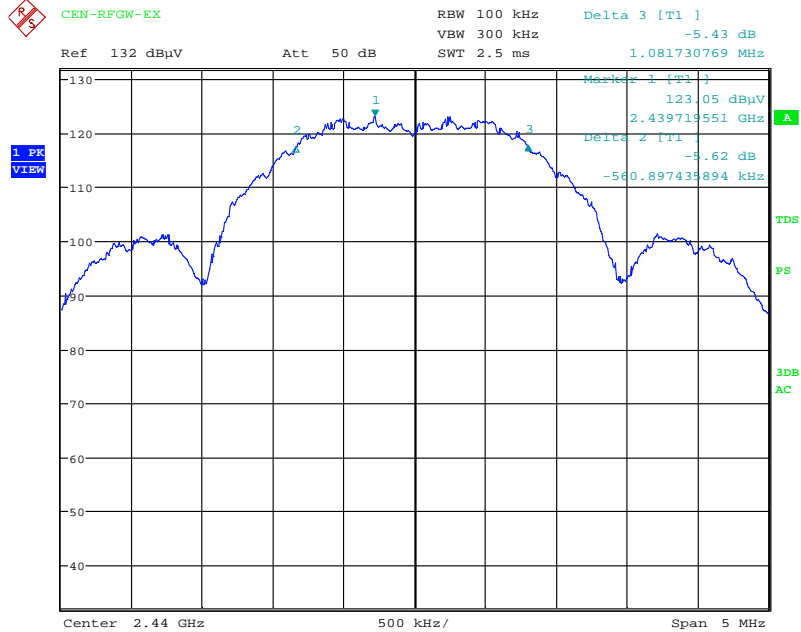

Date: 22.JUL.2010 11:00:19



6 dB Bandwidth, Channel 26:

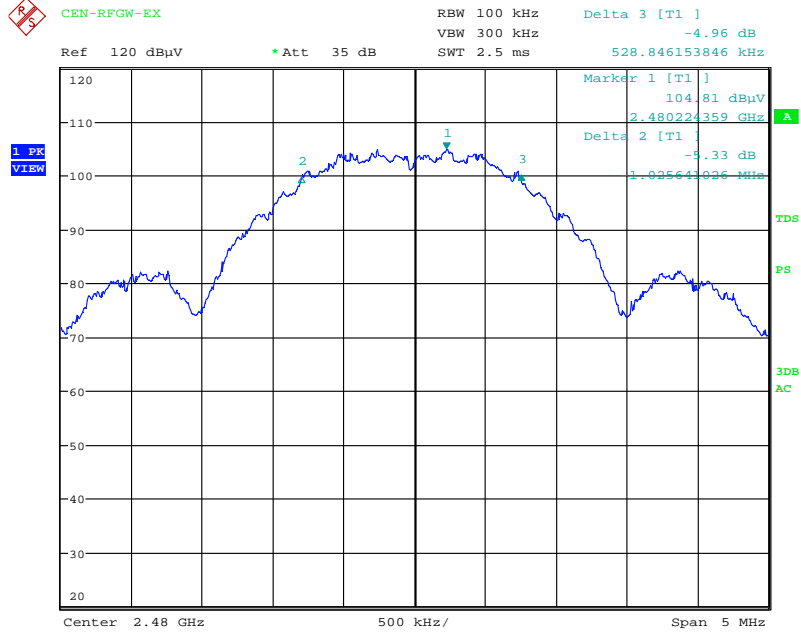

Date: 22.JUL.2010 11:03:25



3.3 Power Output

Performance Criterion: The maximum peak conducted output power shall not exceed 1 Watt.

Test Results: Complies

Test Details: The EUT was tested in a continuous transmit mode with maximum power levels at boost mode. Refers to the following block diagram, data table, and receiver screen captures.

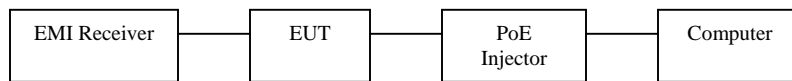

Channel	Frequency (MHz)	Power Level	Power	
			dBm	mW
11	2405	3	20.03	100.69
18	2440	3	17.41	55.08
26	2480	236	1.34	1.36

Note: The insertion loss was compensated for in the receiver.



Power Output, Channel 11:

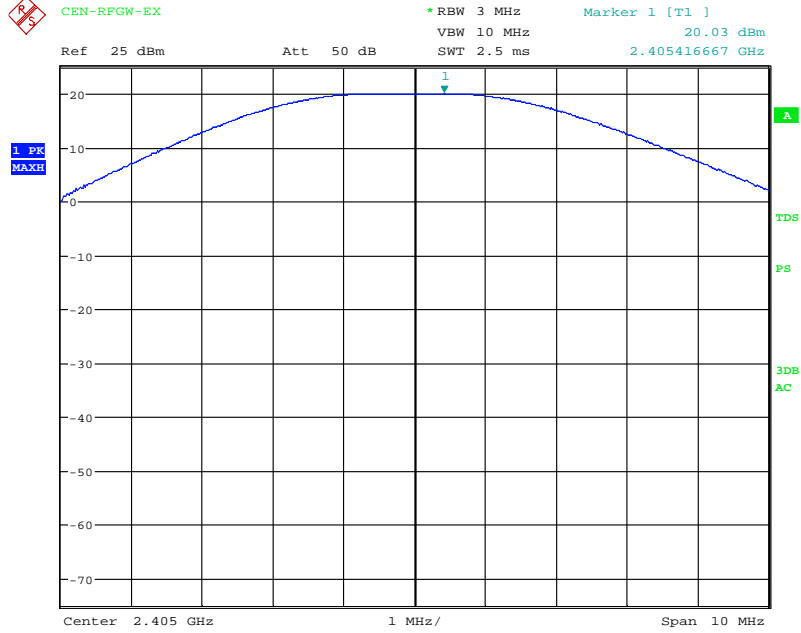

Date: 22.JUL.2010 10:51:11

Power Output, Channel 18:

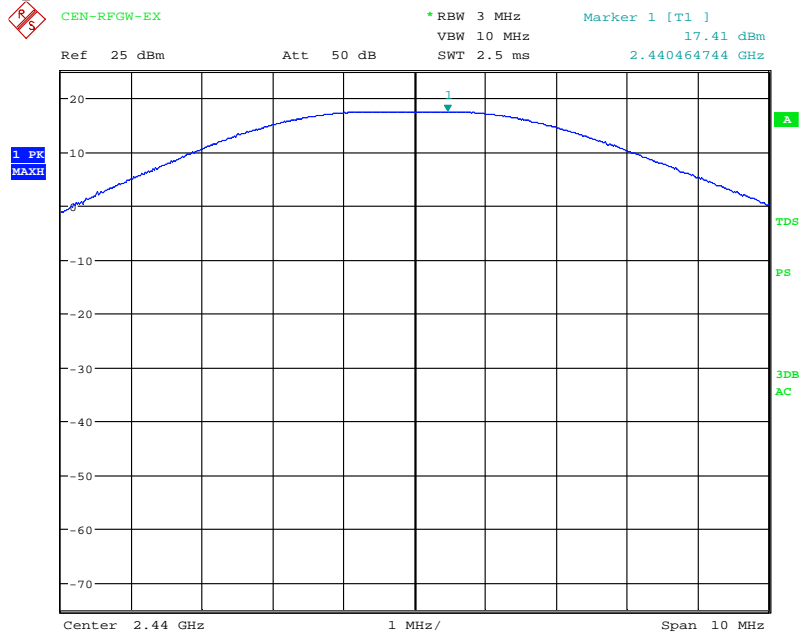

Date: 22.JUL.2010 10:49:46



Power Output, Channel 26:

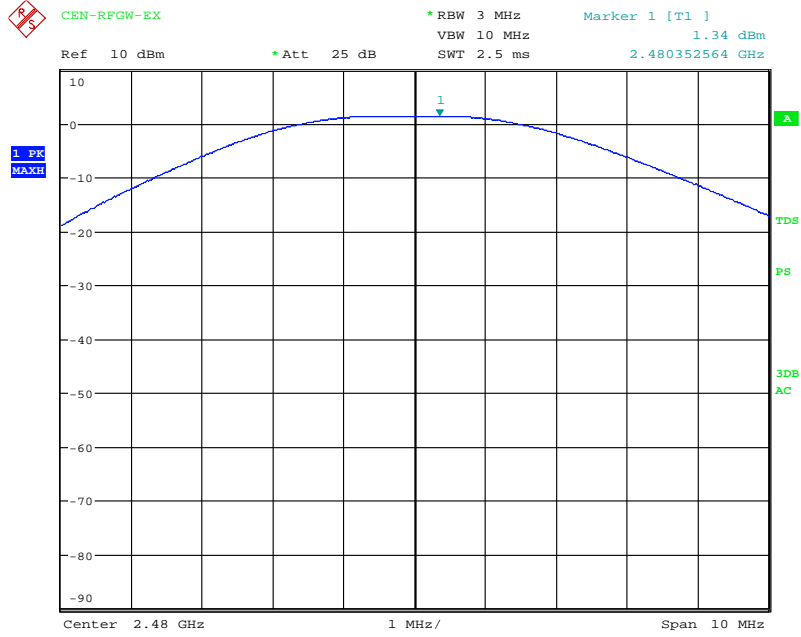

Date: 22.JUL.2010 10:47:41



3.4 *Band Edge*

Performance Criterion: In any 100 kHz bandwidth outside the frequency band, the RF power shall be at least 20 dB below that in the 100 kHz bandwidth within the band.

Test Results: Complies

Test Details: Refers to the following block diagram and receiver screen captures

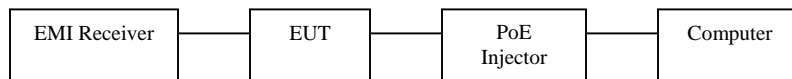



Band Edge:

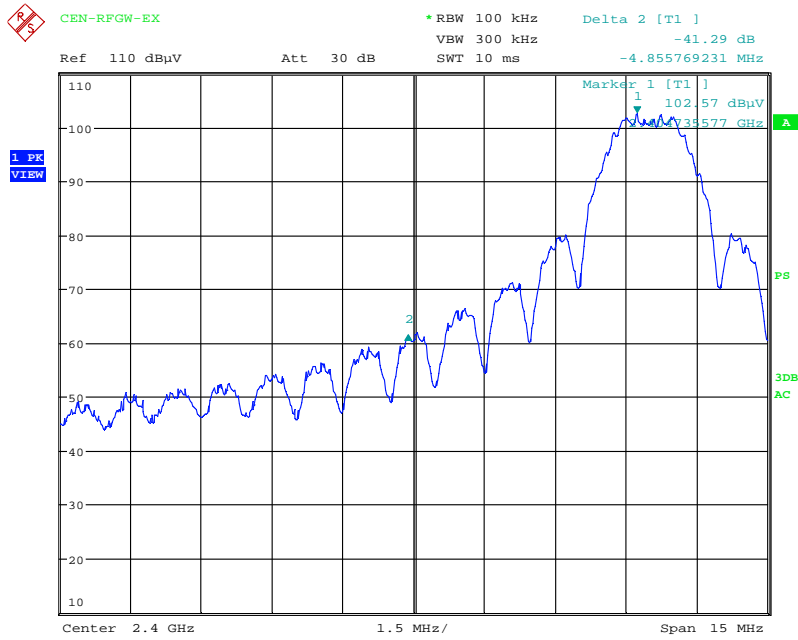

Date: 22.JUL.2010 11:10:45

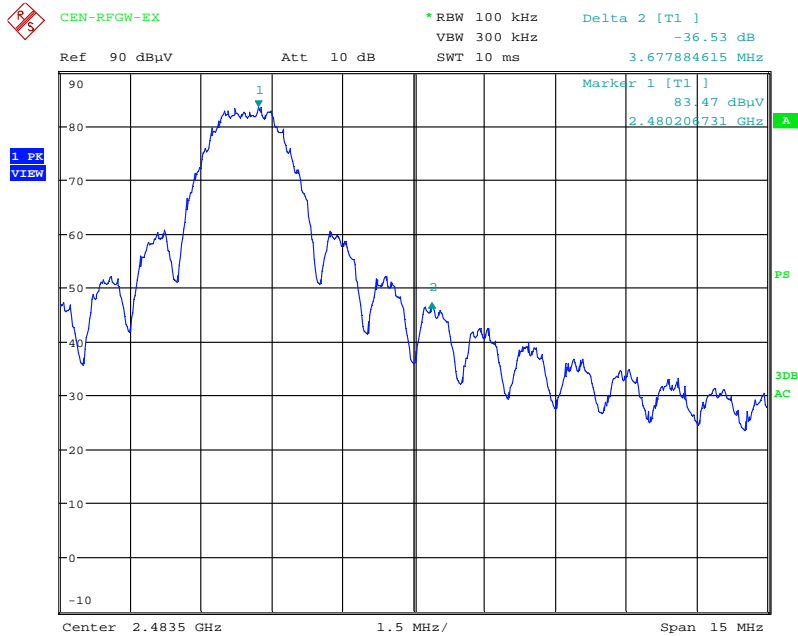

Date: 22.JUL.2010 11:12:16

3.5 *Conducted Spurious Emissions*

Performance Criterion: In any 100 kHz bandwidth outside the frequency band, the radio frequency power shall be at least 20 dB below that in the 100 kHz bandwidth within the band.

Test Results: Complies

Test Details: Refers to the following block diagram and receiver screen captures

Note: The EUT was tested in a continuous transmit mode with maximum power levels at boost mode. The RF level in the screen captures is relative and is not the indication of RF output power.

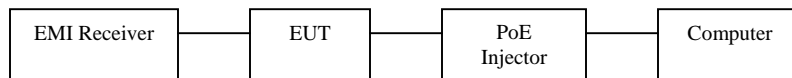



Conducted Spurious Emission – Channel 11

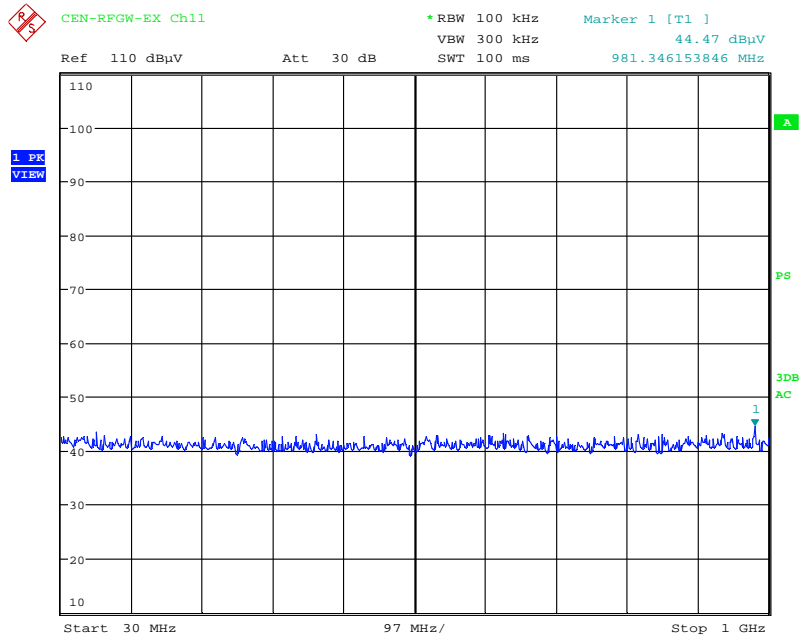

Date: 22.JUL.2010 11:21:53

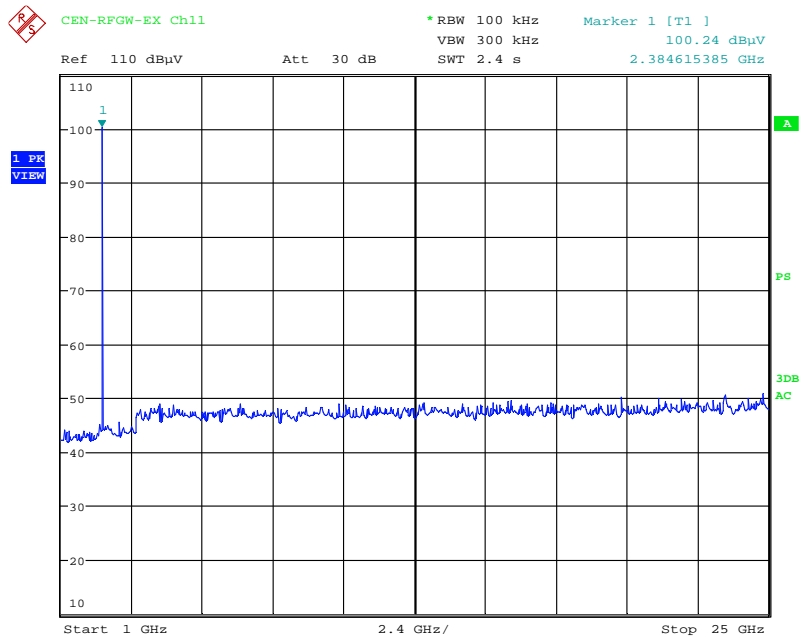

Date: 22.JUL.2010 11:22:55



Conducted Spurious Emission – Channel 18

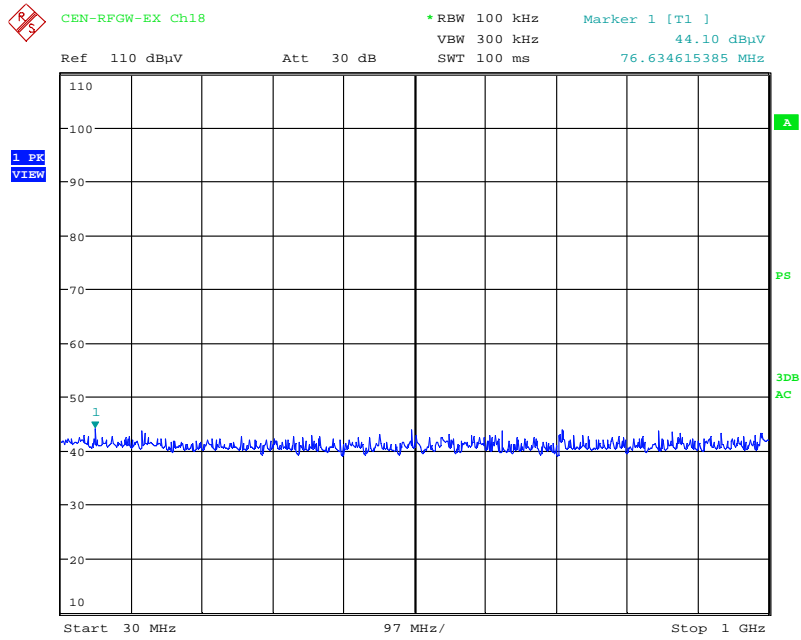

Date: 22.JUL.2010 11:20:38

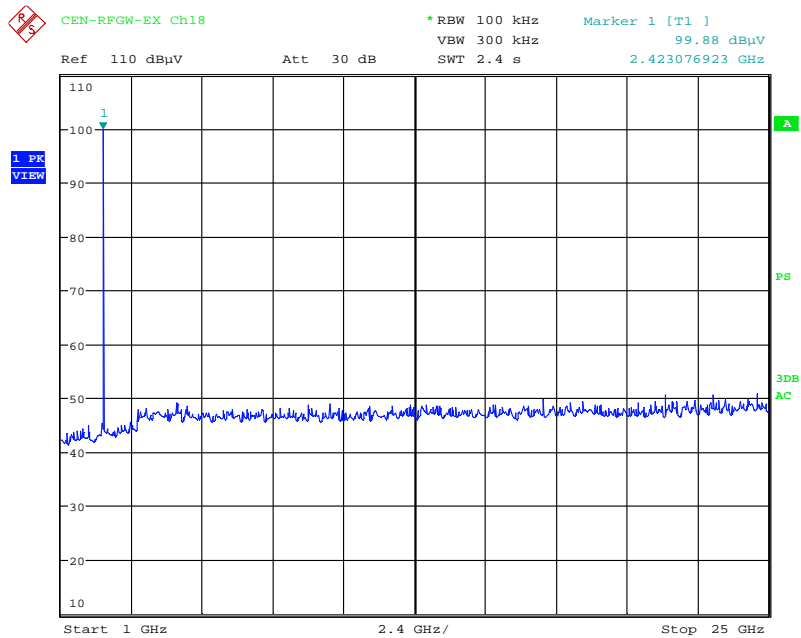

Date: 22.JUL.2010 11:19:54



3.6 Power Spectral Density

Performance Criterion: The power spectral density shall not be greater than 8 dBm in any 3 kHz band.

Test Results: Complies

Test Details: The EUT was tested in a continuous transmit mode with maximum power levels of 0 (channels 11 and 18) and 230 (channel 26) at boost mode. Refers to the following table and receiver screen captures. The insertion loss was compensated for in the receiver.

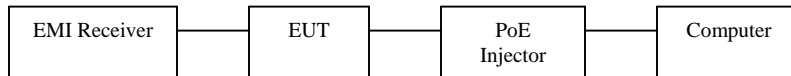

Channel	Frequency (MHz)	Power Spectral Density (dBm)
11	2405	5.44
18	2440	5.79
26	2480	-13.78



Power Spectral Density, Channel 11:

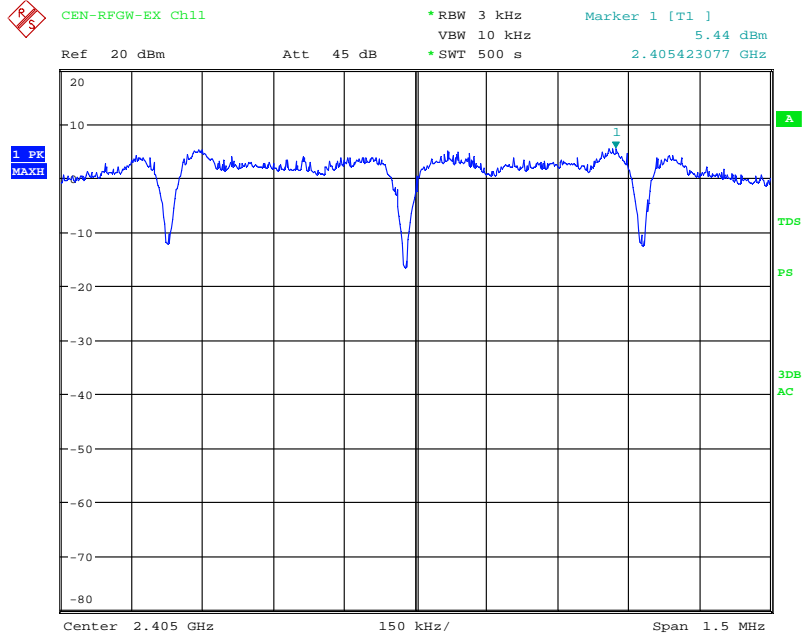

Date: 22.JUL.2010 11:59:49

Power Spectral Density, Channel 18:

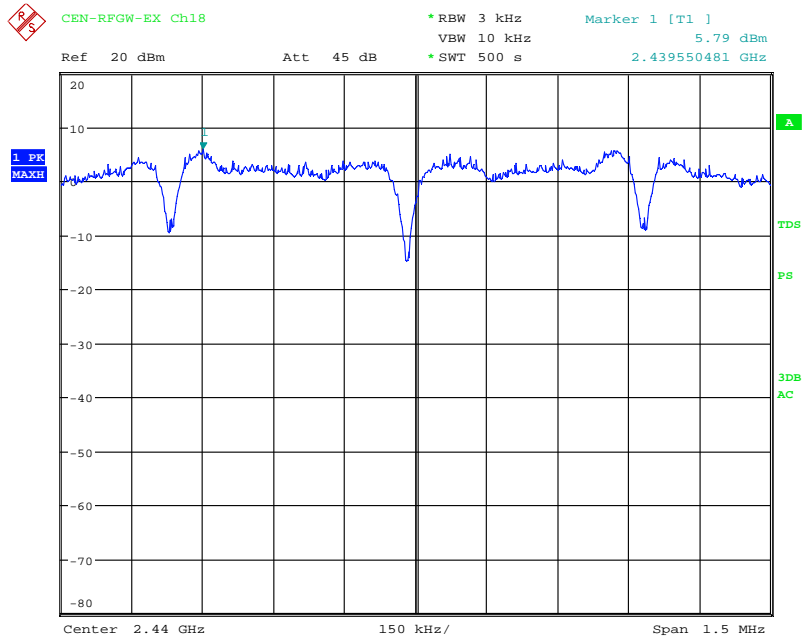

Date: 22.JUL.2010 11:49:38



Power Spectral Density, Channel 26:

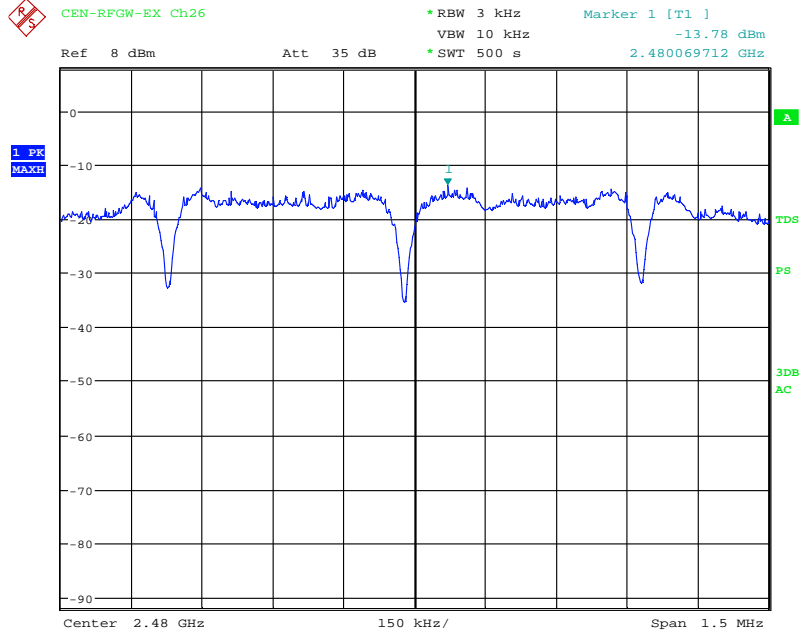

Date: 22.JUL.2010 11:38:26

3.7 Radiated Spurious Emissions

Performance Criterion: Radiated spurious emissions which fall in the restricted bands must comply with the radiated emission limits specified in FCC § 15.209(a) and Table 2 of IC RSS-210.

Test Results: Complies

Test Details: Radiated spurious emission was performed from 30 MHz to the tenth harmonics of the carrier. For each scan of radiated emission measurement, the procedures for maximizing emissions were followed. The EUT was rotated and antenna height was varied between 1 m and 4 m in order to maximize the emission. Measurements in both horizontal and vertical polarities were made and the data was recorded. All radiated emission measurements, up to 18 GHz, were performed at 3-meter distance between an antenna and the EUT. All radiated emission measurements, above 18 GHz, were performed at 1-meter distance between an antenna and the EUT.

The peak level of radiated emissions above 1 GHz was measured with a resolution bandwidth (RBW) of 1 MHz and a video bandwidth (VBW) of 3 MHz.

For harmonics/spurs that fall in the restricted band, the radiated spurious emissions above 1 GHz were measured with RBW of 1 MHz, VBW of 10 Hz, and Sweep of Auto. The unit was configured for continuous operation.

EUT was tested in three orthogonal orientations (XY, YZ, and ZX planes) with antenna at 0 and 90 degrees.

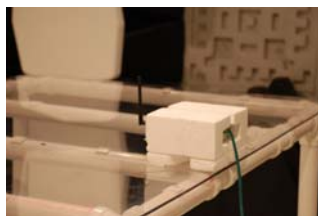

EUT = XY

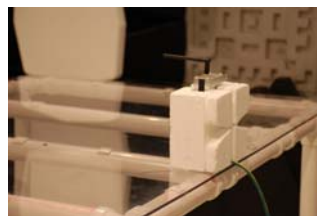

EUT = YZ



EUT = ZX



Antenna = 0



Antenna = 90



Refers to the following block diagram and data table for test data. Antenna factor, cable loss, and preamplifier gain were compensated for in the receiver. A factor of 20 dB/decade applies to measurements made at a closer distance than the limit distance before comparing to the limits.

Duty cycle calculation and screen shots are included in the Theory of Operation.

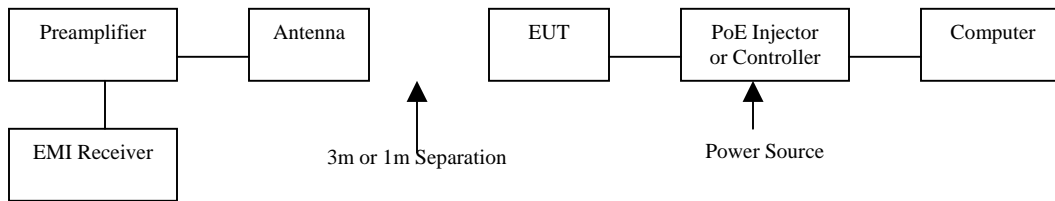

CEN-RFGW-EX, Radiated Spurious Emissions

Antenna Polarization	Frequency (MHz)	Channel No.	Power Setting (Level)	EUT Orientation	EUT Ant Orientation	Measured Data (dBuV/m)	Duty Cycle Correction Factor (dB)	Corrected Data	Limit (dBuV/m)	Margin (dB)	Antenna Height (cm)	Tumble Degree	Detector
V	2405	11	3	XY	90	118.52	-	-	-	-	178.3	163.3	AVE
V	2405	11	3	XY	90	122.09	-	-	-	-	178.3	163.3	PK
V	2390	11	3	XY	90	50.84	15	35.84	54	18.16	178.3	163.3	AVE
V	2390	11	3	XY	90	62.33	0	62.33	74	11.67	178.3	163.3	PK
V	4810	11	3	XY	90	38.93	15	23.93	54	30.07	177.8	13.6	AVE
V	4810	11	3	XY	90	51.72	0	51.72	74	22.28	177.8	13.6	PK
V	12025	11	3	XY	90	41.56	15	26.56	54	27.44	103.2	359.9	AVE
V	12025	11	3	XY	90	54.82	0	54.82	74	19.18	103.2	359.9	PK
V	19240 (NF)*	11	3	XY	90	32.59	15	17.59	54	36.41	-	-	AVE
V	19240 (NF)*	11	3	XY	90	46.46	0	46.46	74	27.54	-	-	PK
V	2440	18	3	XY	90	118.21	-	-	-	-	174.7	176.2	AVE
V	2440	18	3	XY	90	121.34	-	-	-	-	174.7	176.2	PK
V	4880	18	3	XY	90	39.39	15	24.39	54	29.61	128.8	282.5	AVE
V	4880	18	3	XY	90	51.36	0	51.36	74	22.64	128.8	282.5	PK
V	7320	18	3	XY	90	43.06	15	28.06	54	25.94	184.2	185.6	AVE
V	7320	18	3	XY	90	55.10	0	55.10	74	18.90	184.2	185.6	PK
V	12200	18	3	XY	90	47.19	15	32.19	54	21.81	100.0	183.5	AVE
V	12200	18	3	XY	90	58.60	0	58.60	74	15.40	100.0	183.5	PK
V	19520*	18	3	YZ	0	35.65	15	20.65	54	33.35	100.0	0.0	AVE
V	19520*	18	3	XY	90	48.93	0	48.93	74	25.07	100.0	0.0	PK
V	2480	26	236	XY	90	98.64	-	-	-	-	146.2	184.7	AVE
V	2480	26	236	XY	90	101.65	-	-	-	-	146.2	184.7	PK
V	2483.5	26	236	XY	90	61.68	15	46.68	54	7.32	146.2	184.7	AVE
V	2483.5	26	236	XY	90	72.3	0	72.3	74	1.7	146.2	184.7	PK
V	2483.5	25	3	XY	90	58.59	15	43.59	54	10.41	144.3	184.3	AVE
V	2483.5	25	3	XY	90	71.19	0	71.19	74	2.81	144.3	184.3	PK
V	4960	26	236	XY	90	33.89	15	18.89	54	35.11	101.8	185.1	AVE
V	4960	26	236	XY	90	47.37	0	47.37	74	26.63	101.8	185.1	PK
V	7440 (NF)	26	236	XY	90	36.30	15	21.30	54	32.70	-	-	AVE
V	7440 (NF)	26	236	XY	90	47.81	0	47.81	74	26.19	-	-	PK
V	12400 (NF)	26	236	XY	90	41.05	15	26.05	54	27.95	-	-	AVE
V	12400 (NF)	26	236	XY	90	52.37	0	52.37	74	21.63	-	-	PK
V	19840 (NF)*	26	236	XY	90	32.22	15	17.22	54	36.78	-	-	AVE
V	19840 (NF)*	26	236	XY	90	45.70	0	45.70	74	28.30	-	-	PK
V	22320 (NF)*	26	236	XY	90	32.88	15	17.88	54	36.12	-	-	AVE
V	22320 (NF)*	26	236	XY	90	46.99	0	46.99	74	27.01	-	-	PK

NF: Noise Floor

*: Tested at 1m

Tested: July 13-22, 2010

Tested by: Grace Lin



3.8 Transmitter AC Power Line Conducted Emissions

Performance Criterion: AC power line conducted emissions shall not exceed the limits specified in FCC § 15.207 and Table 2 of IC RSS-Gen.

Test Results: Complies.

Test Details: AC power line conducted emissions were performed from 150 kHz to 30 MHz and measured with a resolution bandwidth of 9 kHz. EUT was set in the receiving mode. Refers to the following screen captures (using a peak detector) and block diagram.

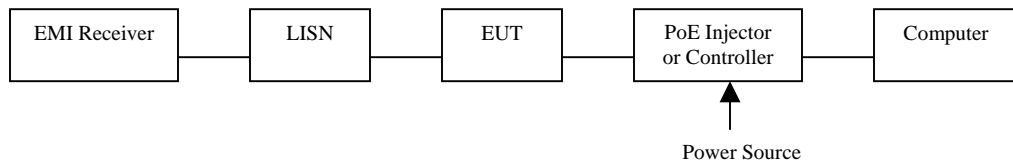

Cresnet Port, TX, Line 1:

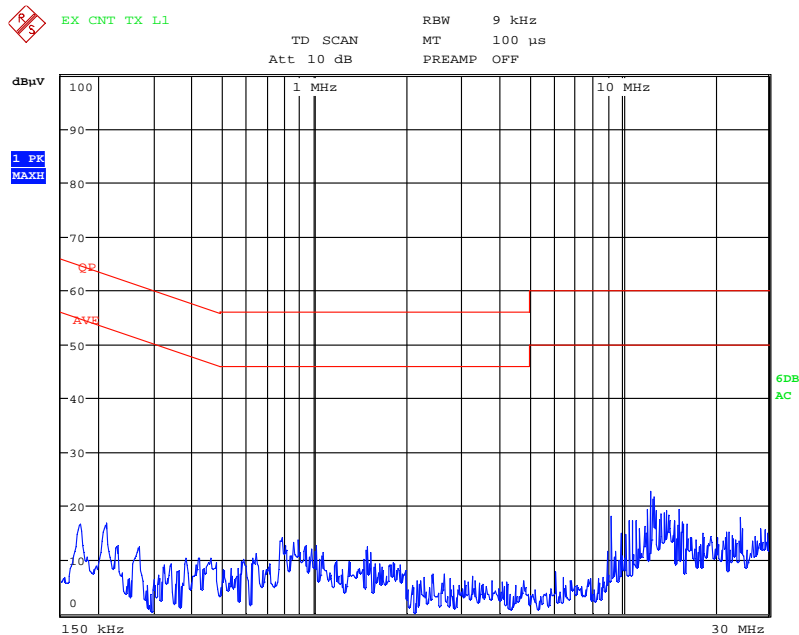

Date: 11.AUG.2010 11:26:14



Cresnet Port, TX, L2:

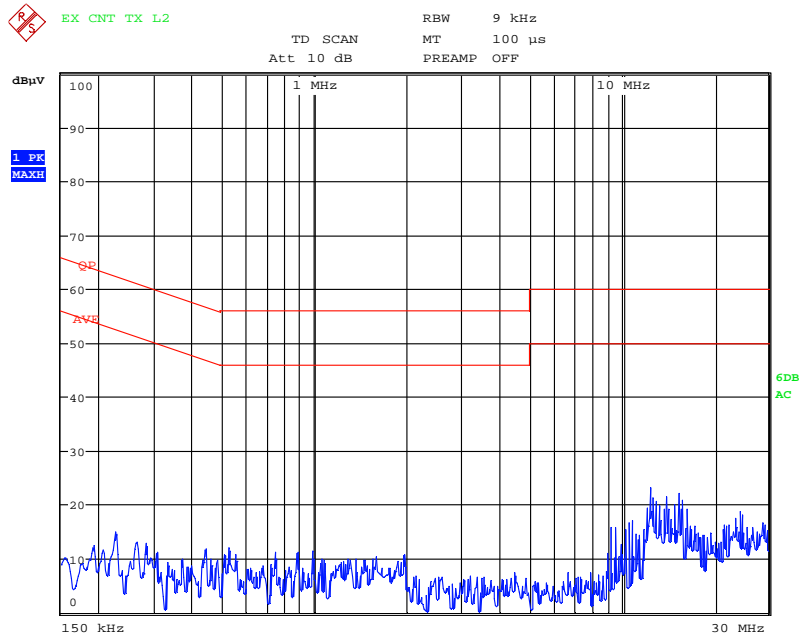

Date: 11.AUG.2010 11:25:07

LAN PoE Port:

LAN PoE Port, TX, Line 1:

Frequency (MHz)	Measured Level (dBμV)		Limit (dBμV)		Margin (dB)
	Quasi-Peak	Average	Quasi-Peak	Average	
0.33225	45.2	44.8	59.4	49.4	4.6
0.3975	44.6	44.3	57.9	47.9	3.6
0.46275	40.4	39.9	56.6	46.6	6.8
0.72825	39.3	38.9	56.0	46.0	7.1
0.79575	39.7	39.1	56.0	46.0	6.9
4.2405	40.0	39.5	56.0	46.0	6.5

Tested by: Grace Lin

Date of Test: August 11, 2010

LAN PoE Port, TX, Line 2:

Frequency (MHz)	Measured Level (dBμV)		Limit (dBμV)		Margin (dB)
	Quasi-Peak	Average	Quasi-Peak	Average	
0.33225	44.4	44.1	59.4	49.4	5.3
0.3975	43.4	43.0	57.9	47.9	4.9
0.4635	40.0	39.4	56.6	46.6	7.3
0.72825	38.4	37.9	56.0	46.0	8.2
0.79575	38.8	38.3	56.0	46.0	7.7
4.2405	39.1	38.7	56.0	46.0	7.3

Tested by: Grace Lin

Date of Test: August 11, 2010

3.9 Receiver Radiated Emissions

Performance Criterion: Receiver radiated emissions must meet the requirements of Table 1 of IC RSS-Gen. Receivers operating above 960 MHz or below 30 MHz are exempt from complying with the technical provisions of FCC Part 15 Subpart B.

Test Results: Complies

Test Details: Radiated emission was performed from 30 MHz to the fifth harmonics of the carrier. For each scan of radiated emission measurement, the procedures for maximizing emissions were followed. The EUT was rotated and antenna height was varied between 1 m and 4 m in order to maximize the emission. Measurements in both horizontal and vertical polarities were made and the data was recorded. All radiated emission measurements, up to 18 GHz, were performed at 3-meter distance between an antenna and the EUT.

For the measurement of radiated emission at the frequency range 30-1000MHz, measurement was made by using a quasi-peak detector with a 120 kHz bandwidth. For the frequency range above 1 GHz, measurement was made using an average detector with a 1 MHz bandwidth.

EUT was tested in three orthogonal orientations (XY, YZ, and ZX planes) with antenna at 0 and 90 degrees.

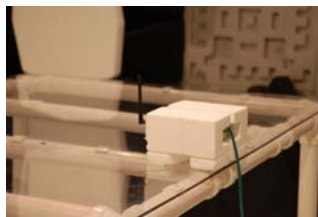

EUT = XY

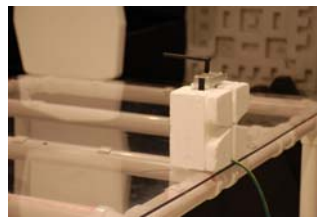

EUT = YZ

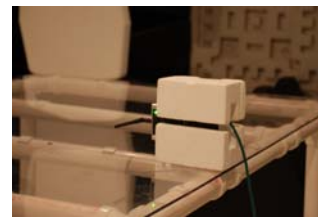

EUT = ZX

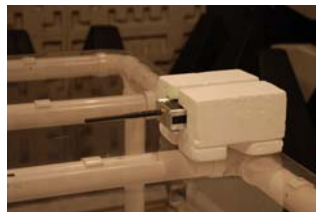

Antenna = 0



Antenna = 90



Refers to the following block diagram and receiver screen captures for test data. Antenna factor, cable loss, and preamplifier gain were compensated for in the receiver.

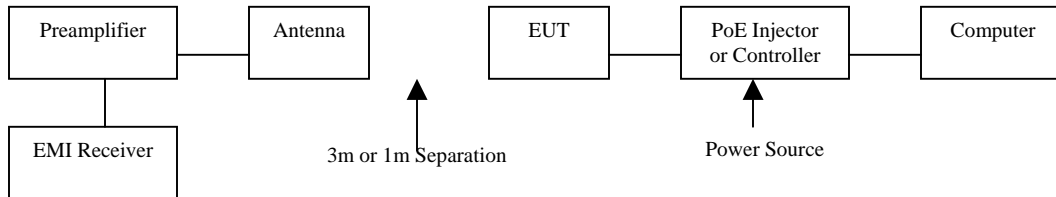

Antenna Polarization	Frequency (MHz)	Channel No.	EUT Orientation	Measured Data (dBuV/m)	Limit (dBuV/m)	Margin (dB)	Antenna Height (cm)	Turntable Degree	Detector
CEN-RFGW-EX, PoE Port, Radiated Emissions, Receiver Mode									
V	103	11	XY	36.1	43.5	7.4	100.0	147.2	QP
V	450	11	YZ	39.3	46	6.7	129.0	152.5	QP
V	750	11	YZ	44.1	46	1.9	160.8	198.8	QP
V	1125	18	YZ	47.3	54	6.68	100.0	130.4	AVE
H	1800	11	XY	46.7	54	7.27	120.5	178.4	AVE
V	1950	18	YZ	50.9	54	3.13	100.0	263.9	AVE
CEN-RFGW-EX, Cresnet Port, Radiated Emissions, Receiver Mode									
V	450	11	YZ	35.82	46	10.2	118.5	236.4	QP
V	575	11	YZ	36.88	46	9.1	100.0	190.0	QP
V	900	11	ZX	34.8	46	11.2	100.0	357.6	QP
V	1800	18	YZ	46.84	54	7.2	126.4	142.4	AVE
V	1950	18	ZX	49.16	54	4.8	117.1	359.9	AVE
V	2850	18	ZX	41.61	54	12.4	122.5	266.0	AVE

Tested by: Grace Lin

Dates of Test: July 16-21, 2010



3.10 Receiver AC Power Line Conducted Emissions

Performance Criterion: AC power line conducted emissions shall not exceed the limits specified in FCC § 15.107 and Table 2 of IC RSS-Gen.

Test Results: Complies.

Test Details: AC power line conducted emissions were performed from 150 kHz to 30 MHz and measured with a resolution bandwidth of 9 kHz. EUT was set in the receiving mode. Refers to the following screen captures (using a peak detector) and block diagram.

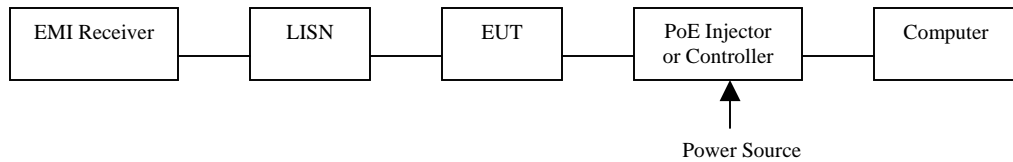

Cresnet Port, RX, Line 1:

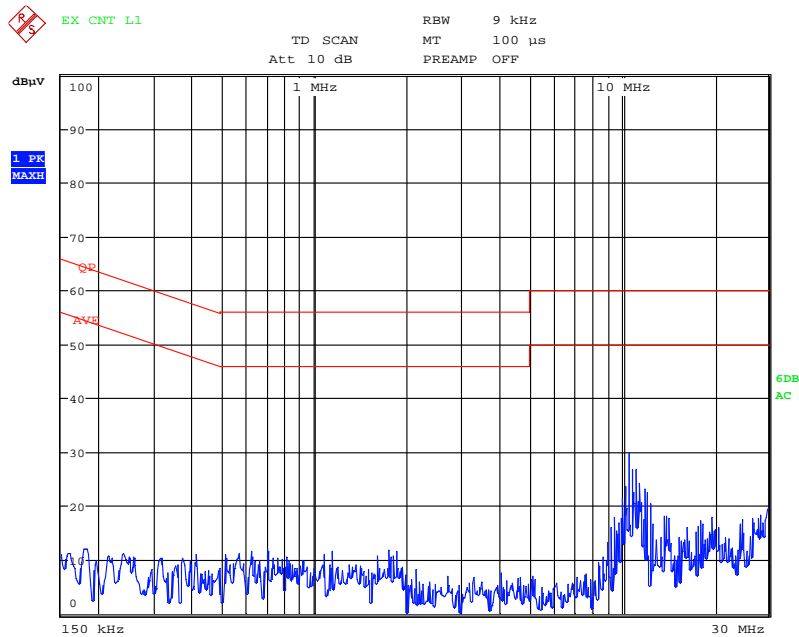

Date: 21.JUL.2010 13:43:46



Cresnet Port, RX, L2:

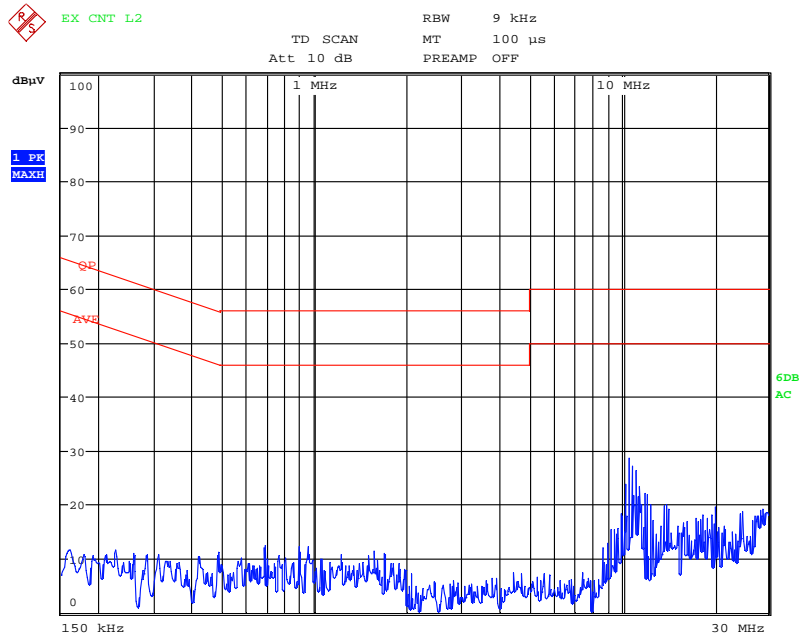

Date: 21.JUL.2010 13:45:28

LAN PoE Port, RX:

LAN PoE Port, Line 1:

Frequency (MHz)	Measured Level (dBuV)		Limit (dBuV)		Margin (dB)
	Quasi-Peak	Average	Quasi-Peak	Average	
0.33077	42.0	41.1	59.4	49.4	8.3
0.397	47.2	46.8	57.9	47.9	1.1
0.46275	40.2	39.7	56.6	46.6	7.0
0.7935	40.9	40.6	56.0	46.0	5.4
1.32227	39.3	39.0	56.0	46.0	7.0
4.497	34.3	32.5	56.0	46.0	13.5

Date of Test: July 21, 2010

LAN PoE Port, Line 2:

Frequency (MHz)	Measured Level (dBuV)		Limit (dBuV)		Margin (dB)
	Quasi-Peak	Average	Quasi-Peak	Average	
0.33077	43.3	43.0	59.4	49.4	6.5
0.397	44.2	43.7	57.9	47.9	4.2
0.46275	39.7	39.2	56.6	46.6	7.4
0.7935	39.6	38.9	56.0	46.0	7.1
1.32227	37.6	37.0	56.0	46.0	9.0
4.497	32.9	30.9	56.0	46.0	15.1

Date of Test: July 21, 2010