

Integra-TR

Technical Manual

Version 0.02

PRELIMINARY

The entire contents of this manual and the Software described
in this manual are copyright 1999 by Dataradio Inc.

Copyright DATARADIO Inc.
February 1999

Part no.: 120 4010x-002

Table of Contents

1. PRODUCT OVERVIEW	1
1.1 INTENDED AUDIENCE	1
1.2 GENERAL DESCRIPTION	1
1.2.1 Characteristics	1
1.2.2 Accessories and options	1
1.3 CONFIGURATION	1
1.4 FACTORY TECHNICAL SUPPORT	2
1.5 PRODUCT WARRANTY	2
1.6 REPLACEMENT PARTS	2
1.6.1 Factory Repair	2
1.7 PHYSICAL DESCRIPTION	2
1.8 DIAGNOSTICS	2
1.8.1 Remote Commands	3
1.9 FIRMWARE UPGRADES	3
1.10 NETWORK APPLICATION	3
1.10.1 RF Path and Communications Range	3
1.10.2 Basic Connections	3
1.10.3 Common Characteristics	3
1.10.4 Point to Point System	3
1.10.5 Point–Multipoint System	4
1.10.6 Extending a Landline (Tail Circuit)	4
2. FEATURES AND OPERATION	5
2.1 OVERVIEW	5
2.2 INTENDED AUDIENCE	5
2.3 FRONT PANEL	5
2.3.1 Antenna Connector	5
2.3.2 LED Indicators	5
2.3.3 Connection to DTE	5
2.3.4 Com Port	6
2.3.5 Setup Port	6
2.4 REAR PANEL	7
2.4.1 Heat Sink	7
2.4.2 Power / Analog connector	7
2.5 OPERATION	7
2.5.1 Operating Modes	8
2.5.2 Data Forwarding Timer	8
2.5.3 Sending Break Signals	8
2.5.4 COM Port Baud Rates	8
2.5.5 Diagnostics	8
2.5.6 Addressing	9
2.5.7 Station Type	9
2.6 ONLINE DIAGNOSTICS	9
2.6.1 Using an External Program for Online Diagnostics	9
2.6.2 Interpreting Diagnostic Results	10
2.7 OFFLINE DIAGNOSTICS	12
2.8 LOW POWER OPERATION	13
2.8.1 Reduced Transmit Power	13
2.8.2 Suspend Mode	13

2.8.3	<i>Sleep Mode</i>	13
2.8.4	<i>Remote Unit Wake-up by DTE</i>	13
2.9	TRANSMITTER TIMEOUT.....	13
2.10	OPTIMIZING YOUR SYSTEM.....	14
3.	MAINTENANCE ADJUSTMENTS	15
3.1	OVERVIEW AND MAINTENANCE INTERVALS.....	15
3.2	INTENDED AUDIENCE.....	15
3.3	EQUIPMENT REQUIRED.....	15
3.4	TEST POINT.....	15
3.5	BASIC ADJUSTMENTS.....	15
3.5.1	<i>Preliminary Steps</i>	15
3.5.2	<i>After Adjustments are Done</i>	15
4.	CIRCUIT DESCRIPTION	17
4.1	OVERVIEW.....	17
4.2	INTENDED AUDIENCE.....	17
4.3	CIRCUIT DESCRIPTION.....	17
4.3.1	<i>Microprocessor Circuit</i>	17
4.3.2	<i>RS232</i>	17
4.3.3	<i>MODEM</i>	17
4.3.4	<i>TRANSMIT & RECEIVE DATA</i>	17
4.3.5	<i>Integra-R A/D and DIGIPOT</i>	18
4.3.6	<i>Wake-Up Circuit</i>	18
4.3.7	<i>Power Supply</i>	18
	TABLE 1 INTEGRA-T ACCESSORIES AND OPTIONS.....	1
	TABLE 2: COM PORT SIGNALS.....	6
	TABLE 3: SETUP PORT SIGNALS.....	6
	TABLE 4: SWR / REV PWR.....	12
	TABLE 5: TESTS AND ADJUSTMENTS HALF AND FULL CHANNEL UNITS.....	16
	FIGURE 1 - BASIC CONNECTIONS REQUIRED.....	3
	FIGURE 2 - POINT TO POINT SYSTEM.....	4
	FIGURE 3 - POINT-MULTIPOINT SYSTEM.....	4
	FIGURE 4 - TAIL CIRCUIT.....	4
	FIGURE 5 - DCE CROSSOVER CABLE FOR RTS-CTS MODE.....	4
	FIGURE 6 - INTEGRA-T FRONT PANEL.....	5
	FIGURE 7 - COM AND SETUP PORT CONNECTORS PIN LOCATIONS.....	6
	FIGURE 8 - 3-WIRE INTERFACE.....	6
	FIGURE 9 - INTEGRA-T REAR PANEL.....	7
	FIGURE 10 - POWER / ANALOG CONNECTOR.....	7
	FIGURE 11- POWER / ANALOG CABLE.....	7
	FIGURE 12 - LOGIC BOARD BLOCK DIAGRAM.....	19

What's New in this Version

Document various corrections

History

0.01: This version 0.01 of the first preliminary version of the Integra-TR technical manual will be replacing the Integra-T manual versions. The Integra-TR is compliant to the FCC refarming (19.2Kb/s in 25KHz channels and 9.6KHz in 12.5KHz channels).

Definitions

The following terms are used throughout this document.

Bit dribble	Extraneous bits delivered at the end of a data transmission. Equivalent to a “squelch tail” in voice systems. Integra-T does not have bit dribble.
COM Port	The Communications Port of Integra-T. This port is configured as DCE and is designed to connect directly to DTE.
CTS	Clear to Send. An RS-232 output signal from Integra-T indicating that it is ready to accept data.
DCE	Data Communications Equipment. This designation is applied to equipment such as modems. DCE is designed to connect to DTE.
DOX	Data Operated Transmit. A mode of operation in which Integra-T begins a transmission as soon as data is presented to the RS-232 port.
DTE	Data Terminal Equipment. This designation is applied to equipment such as terminals, PCs, RTUs, PLCs, etc. DTE is designed to connect to DCE.
Network speed	This is the <i>bit rate</i> on the RF link between units. Could be different from COM port <i>baud rate</i> .
PLC	Programmable Logic Controller. An intelligent device that can make decisions, gather and report information, and control other devices.
RDS	Radio Diagnostic Software. This software allows local and remote diagnostics of Integra-T.
RRSS	Remote Radio Setup Software. (Future expansion software package)
RSS	Radio Service Software. This software allows configuration and testing of Integra-T.
RTS	Request to Send. RS-232 input signal to Integra-T indicating that the DTE has data to send. RTS may optionally be used as a transmit switch for Integra-T.
RTS mode	A mode of operation in which Integra-T begins a transmission when RTS is raised, and continues transmitting until RTS is dropped.
RTU	Remote Terminal Unit. A SCADA device used to gather information or control other devices.
SCADA	Supervisory Control And Data Acquisition. A general term referring to systems that gather data and/or perform control operations.
SETUP Port	The configuration / diagnostic port of Integra-T. This port is designed to be connected to a PC running the Integra RSS program.
Transparent	A transparent unit transmits all data without regard to special characters, etc.

1. PRODUCT OVERVIEW

This document provides the information required for the installation, operation and maintenance of the Dataradio Integra-TR radio-modem.

1.1 Intended Audience

This manual is intended for use by system designers, installers and maintenance technicians

1.2 General Description

Integra-TR is a high-speed transparent radio-modem, FCC refarmed compliant, designed specifically to fit the needs of SCADA, telemetry and control applications. Integra-TR provides the communication links among data equipment for installations where wired communication is impractical.

Integra-TR will work with most makes and models of RTU, PLC and with their protocols (usually polling). Configuration settings allow tailoring for a variety of applications.

Integra-T supports:

1. Point to point Master-Slave or Peer to Peer configurations in simplex or half-duplex modes.
2. Point to multipoint Master-Slave configuration in simplex or half-duplex modes.

Settings and connections for these configurations are given later in this manual.

1.2.1 Characteristics

Integra-TR has the following characteristics:

- Selectable network speeds of 4800, 9600 for half channel units and 4800, 9600 and 19.200 b/s for full channel units.
- Backward compatible with the Integra-T for bit rate of 4800 and 9600 b/s (full channel units only)
- One COM port for connection to DTE. Speeds 300 - 19200 bauds.
- One Setup port, for configuration and diagnostics.
- Built-in 5-watt transceiver, operating in the VHF, UHF or 900 MHz communications bands. Half-duplex or simplex operation.

- Fully transparent operation with error-free data delivery.
- Allows transmission of “break” characters.
- DOX (Data Operated Transmit) or RTS mode.
- Stations may be set as “master” or “remote” to prevent remote stations from hearing each other.
- Full local and remote diagnostics
- Two 8-bit analog inputs (0 - 10V).
- Low power consumption modes: “sleep” and “suspend” modes (nominal 7mA).
- “12 VDC, negative ground”, device.

1.2.2 Accessories and options

Table 1 Integra-T Accessories and options

Accessory	DR Part #
Local RSS & RDS software kit (diskette and setup/data cable)	085 03281-0xx
Technical manual	120 40101-xxx
SMA Male – BNC Female adapter	685 00832 –000
Cooling fan – factory option (for high duty-cycle transmit applications)	Catalog number /F suffix.

For continuous-transmit applications, the “TX Timeout” timer must be turned off (set to “disable”) via the Radio Service Software (RSS).

1.3 Configuration

Operating characteristics of Integra-TR are configured by means of Integra-TR’s *Radio Service Software* (RSS) available from your sales representative. Also available is Integra-T’s *Radio Diagnostic Software* (RDS) which permits both local and remote diagnostics. *Remote Radio Service Software* (RRSS) to allow remote programming is a future expansion. The RSS, RDS and RRSS (future option) programs are MSDOS based and will run on any 486 or higher PC (2 Megabytes memory required).

Integra-TR requires the use of the RSS for both configuration and adjustment.

1.4 Factory Technical Support

The Technical Support departments of Dataradio and Johnson Data Telemetry (JDT) provide customer assistance on technical problems and serve as an interface with factory repair facilities. Technical support hours are respectively: for Dataradio, 9:00 AM to 5:00 PM, Eastern Time, Monday to Friday and for JDT, 7:30 AM to 4:30PM, Central Time, Monday to Friday. Technical support can be reached in the following ways:

For equipment purchased from Dataradio:



Dataradio Inc.
5500 Royalmount Ave, suite 200
Town of Mount Royal
Quebec, Canada H4P 1H7

phone: +1 514 737-0020
fax: +1 514 737-7883

Email address: support@dataradio.com

For equipment purchased from JDT:



Johnson Data Telemetry Corp.
Customer Service Department
299 Johnson Avenue, P.O. Box 1733
Waseca, MN 56093-0833

phone: 1-800-992-7774 and
+1-507 835-6408
fax: +1-507-835-6648

Email address: support@johnsondata.com

1.5 Product Warranty

Warranty information may be obtained by contacting your sales representative.

1.6 Replacement Parts

This product is normally not field-serviceable, except by the replacement of complete units. Specialized equipment and training is required to repair logic boards and radio modules.

Contact Technical Support for service information before returning equipment. A Technical Support representative may suggest a solution eliminating the need to return equipment.

1.6.1 Factory Repair

When returning equipment for repair, you must request an RMA (returned merchandise authorization) number. The Tech Support representative will ask you several questions to clearly identify the problem. Please give the representative the name of a contact person, who is familiar with the problem, in case questions arise during servicing of the unit.

Customers are responsible for shipping charges for returned units. Units in warranty will be repaired free of charge unless there is evidence of abuse or damage beyond the terms of the warranty. Units out of warranty will be subject to service charges. Information about these charges is available from Technical Support.

1.7 Physical Description

Integra-TR consists of a logic PCB (which includes the modem circuitry) and a separate radio module. The two boards plug directly together and slide into the rails of an extruded aluminum case. DTE connection is made via a front panel connector. Power is applied through a connector, which also includes analog inputs, on the rear panel. The unit is not hermetically sealed and should be mounted in a suitable enclosure where dust and/or a corrosive atmosphere are anticipated. There are no external switches or adjustments; operating parameters are set using the RSS.

1.8 Diagnostics

Integra-TR has sophisticated built-in diagnostics that may be transmitted automatically without interfering with normal network operation. In addition, commands to generate test transmissions, etc., may be issued either locally or remotely.

Diagnostic information takes one of two forms:

Online diagnostics. Information is automatically sent by each unit at the beginning of every data transmission.

Offline diagnostics. Information is sent by a specific unit in response to an inquiry made locally or from another station.

Diagnostics are processed using the Integra-TR' RDS.

1.8.1 Remote Commands

The upcoming Integra RRSS will allow configuring most functions and adjustments remotely via the radio network.

Sending remote commands and receiving responses is done with the host application offline.

1.9 Firmware Upgrades

Integra-TR's firmware resides in flash EPROM and is designed to allow field upgrades.

Upgrades are done using a PC connected to Integra-TR and do not require that the unit be opened.

1.10 Network Application

Integra-TR is suited to a variety of network applications. Its primary design goal was to satisfy the needs of SCADA systems using RTUs or PLCs in either point to point or point-multipoint service.

This section gives an overview of some common configurations. Selection of "master" or "remote" as well as data delivery conditions is done using the Integra RSS.

1.10.1 RF Path and Communications Range

Integra-TR is designed for use over distances up to 30 miles (50 km) depending on terrain and antenna system. To assure reliable communications, the RF (radio frequency) path between stations should be studied by a competent professional, who will then determine what antennas are required, and whether or not a repeater is needed.

1.10.2 Basic Connections

The connections required (except power) are shown below in Figure 1.

While an RTU or PLC is shown in the diagram, master stations often use a PC running an application designed to communicate with remote RTUs or PLCs.

The Setup PC is used for both configuration and local and remote diagnostics. It may be left connected at all times if desired, but is not required for normal operation once the unit has been configured.

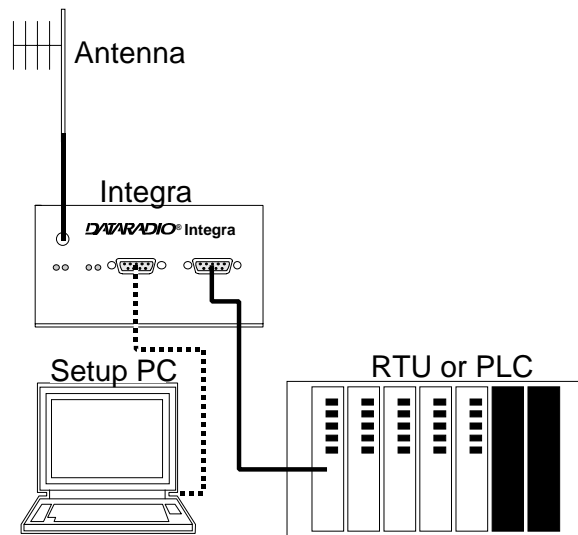

Figure 1 - Basic connections required

1.10.3 Common Characteristics

The networks described below share a number of common characteristics.

1. The network speed (4800 or 9600 b/s) must be the same for all stations in a network.
2. Unless otherwise noted, the default setting of station type is "master" and data delivery is "all".
3. Transmission of online diagnostics may be enabled or disabled at any station or stations without affecting their ability to communicate with other stations.

1.10.4 Point to Point System

A simple point to point connection is shown below:

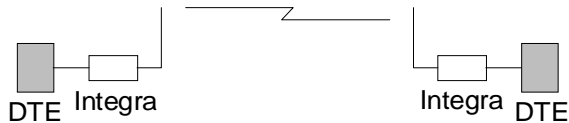

Figure 2 - Point to Point System

In such a system, the user's equipment (DTE) may be set up in either a peer-to-peer or a master slave configuration. The Integra-T's may be left in their default configuration, which is:

1. Both units set as "master".
2. Both units set to deliver "all" data transmissions.

Two other configurations that would work equally well are:

1. One unit set to "master", the other to "remote", delivery set to either "all" or "selective" data transmissions.
2. Both units set to "remote", data delivery set to "all".

1.10.5 Point-Multipoint System

A basic point-multipoint system is shown below:

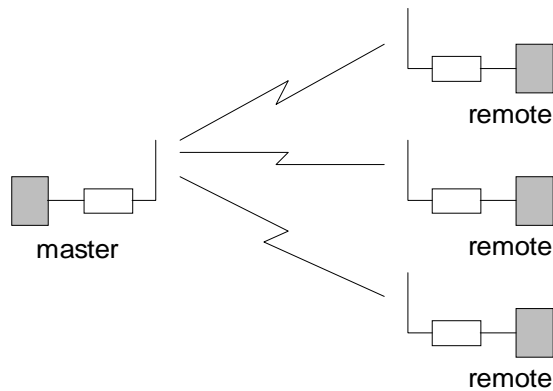

Figure 3 - Point-Multipoint System

If a half-duplex radio network is used (i.e. two frequencies with the master station transmitting and receiving on the reverse pair from the remotes) the Integra-TR's may be left in their default configuration (station type "master" and data delivery "all"). The master station can be either full duplex or half-duplex.

If a simplex radio network is used (i.e. a single frequency for all stations) we recommend that the master Integra-TR be set to "master", the remotes to "remote" and all units to "selective" data delivery. This will prevent remote stations from hearing each other's responses. Use this setting also if a full duplex repeater is used.

1.10.6 Extending a Landline (Tail Circuit)

Integra-TR may be used to extend a landline circuit (giving access to difficult locations, etc.). This type of connection is called a "tail circuit" and is shown in Figure 4 below. The tail circuit assembly may be used in any of the network types described in the preceding sections.

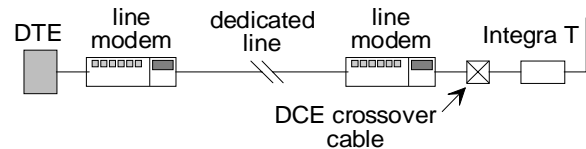

Figure 4 - Tail Circuit

Note: The line modems should be full duplex units.

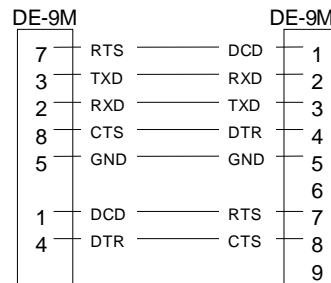

Figure 5 - DCE Crossover Cable for RTS-CTS mode

However, some point-to-point FDX landline modems or line drivers may require the use of DOX mode and an alternate pinout for two of the above lines.

All other lines remain as shown in Figure 5 above.



2. Features and Operation

2.1 Overview

This chapter describes the connections, indicators and operating characteristics of Integra-TR.

2.2 Intended Audience

This chapter is intended for system design and installation personnel.

2.3 Front Panel

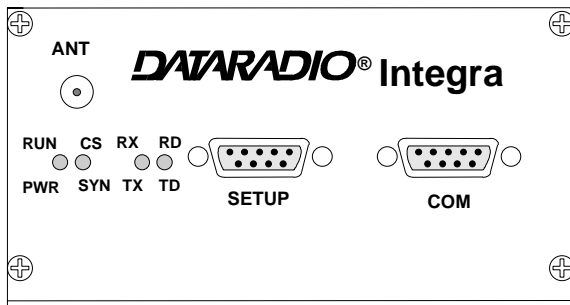

Figure 6 – Integra-T front panel

The various front panel elements are described in the following sections.

2.3.1 Antenna Connector

Antenna connector is a type SMA-female, 50 ohms.

Testing must be done with a 50-ohm dummy load. Units operated with a “rubber duck” antenna connected directly to the antenna connector may exhibit unusual operating characteristics and high levels of reverse power.

2.3.2 LED Indicators

Integra-TR has four two-color LED indicators. Functions are shown in the following table:

RUN/PWR	green	normal operation
	flash green	sleep mode (flashes during wakeup)
	flash red & green	setup mode, or loading new application or new bootloader
	flash red	firmware error *
	red	CPU or PROM failure *
CS/SYN	off	no RF carrier
	green	Receive carrier present
	red	(reserved)
RX/TX	off	Idle
	green	receiving network data
	yellow	synthesizer unlocked
	red	transmitter is on
RD/TD	off	Idle
	green	RX data outgoing from RS-232 port
	red	TX data incoming at RS-232 port

* Contact technical support.

2.3.3 Connection to DTE

Integra-TR is configured as DCE. Most DTE should be connected using a 9-conductor pin to pin “straight” cable.

Some RTUs or PLCs may require a special cable to route the signals correctly. See the documentation for your data equipment for further information.

2.3.3.1 Connector Pinout

For reference, the DE-9 F pinout is shown below:

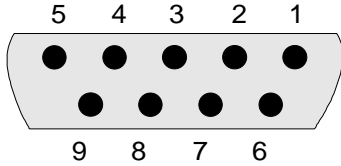

Figure 7 – COM and Setup Port connectors pin locations

2.3.4 Com Port

Baud rates from 300 – 9600 are supported. Unless required by your operating protocol, **we advise restricting port speed to be equal to or less than the RF network speed.**

Table 2: COM port signals

Pin	Name	Function
1	DCD	Output: Always asserted or asserted when RX data available (selectable via RSS)
2	RXD	Output: Data from Integra-T to DTE
3	TXD	Input: Data from DTE to Integra-TR
4	DTR	Input: Ignored
5	GND	Signal and chassis ground
6	DSR	Output: always positive (asserted)
7	RTS	Input: Used as a “begin transmission” signal in RTS mode. Will “wake up” a unit in sleep mode.
8	CTS	Output: Used for handshaking in RTS mode and used for flow control in DOX mode. RTS mode: RTS/CTS delay is 4ms. DOX mode: CTS always asserted, except when data overflow is detected.
9	RI	Not internally connected, reserved

2.3.4.1 3-Wire Connection (DOX)

For DTE that lack RTS control, Integra-TR can operate in DOX mode (Data Operated Transmit) with only Transmit Data, Receive Data and Ground (“3-wire interface”). Integra-T also supports CTS flow control for cases where the terminal rate exceeds the network rate.

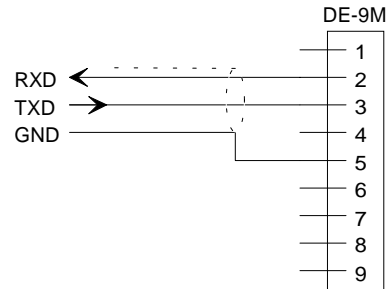

Figure 8 – 3-wire interface

2.3.5 Setup Port

The Setup port uses a DE-9 female connector configured as DCE. Signals are described in the following table.

Table 3: Setup Port signals

Pin	Name	Function
1	DCD	Tied directly to DTR.
2	RXD	Data from Integra-T to setup PC
3	TXD	Data from setup PC to Integra-TR
4	DTR	Tied directly to DCD.
5	GND	Signal and chassis ground
6	DSR	Output; always positive (asserted)
7	RTS	Tied to CTS. Also monitored to “wake up” unit from sleep mode.
8	CTS	Tied to RTS.
9	RI	not internally connected, reserved

The Setup port uses a proprietary communications protocol designed to work with the Integra RSS, the upcoming RRSS and the RDS programs. It is also designed to provide numeric diagnostics information when connected to a PC terminal emulator. For the format, see section 2.6.1.2.

2.4 Rear Panel

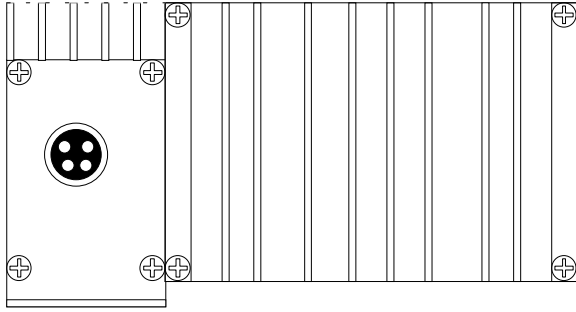

Figure 9 – Integra-T rear panel

The various elements are described in the following sections.

2.4.1 Heat Sink

The rear panel heat sink is essential for proper operation of the Integra-TR transmitter. The unit must be mounted in a location that permits free air circulation past the heat sink. Cooling will be best if the fins are vertical.

2.4.2 Power / Analog connector

The 4 pin power / analog connector pinout is shown below:

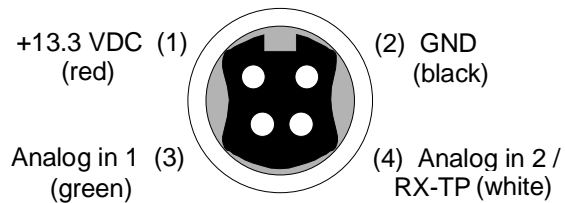

Figure 10 - Power / Analog Connector

2.4.2.1 Power

Integra-TR's power requires a filtered power source of 13.3 VDC nominal (10 – 16 VDC max.), negative ground with a 3.0 A rating. An internal 3A fuse (surface-mount and not field-replaceable) and a crowbar diode protect the main RF power components from reverse polarity. Application of more than 16 VDC will damage the unit and is **not** covered by the warranty.

WARNING: Do not exceed 16Vdc.

Power / Analog cable

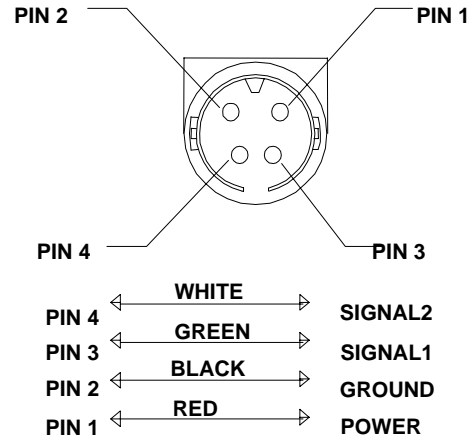

Figure 11- Power / Analog cable

2.4.2.2 Analog inputs

Two analog inputs are provided. Inputs are scaled to 0–10 V and have a resolution of 8 bits (1 part in 256). Inputs are referenced to chassis ground.

The absolute maximum input voltage should be no greater than 20 Vdc. These inputs are reverse-voltage protected.

Integra-TR allows the analog values to be read, either locally or remotely, using the Offline Diagnostics function of the Integra RDS.

Analog in 2 (pin 4) can be switched (using the Integra RSS) to perform as the demodulated signal level test point (RX-TP) which is half of the voltage read at the RSSI bar graph.

If the analog inputs are not used, the green and white wires should be cut back and/or taped to prevent contact.

2.5 Operation

Integra-TR is designed for fully transparent operation. This means that all binary values are transmitted as data, with minimum time delays, and without regard to their binary value. “Break” signals can also be transmitted.

Unlike most transparent radiomodems, Integra-TR eliminates “bit dribble” and allows DOX operation. A CRC-16 error check is used so that faulty data will not be delivered.

2.5.1 Operating Modes

Integra-TR has two operating modes, for its COM port: (selectable via the RSS program)

DOX mode: The RS-232 port is monitored for incoming data. Upon receipt of the first data byte, the transmitter is turned on. The RTS signal is ignored (note: RTS may still be used as a wakeup signal for a unit that is asleep).

RTS mode: The RTS signal is monitored for a low-to-high transition. This transition causes Integra-T to turn on its transmitter. CTS is raised 4 ms later to accommodate DTE that requires a CTS transition before it can send data. The transmission will continue until RTS is dropped, or until the Tx Timeout (see section 2.9) expires.

CTS is used as a handshaking/flow control signal in both modes. If Integra-T’s buffers fill, CTS will be dropped as a signal to the DTE to stop sending data. This condition is most likely when the Data port speed exceeds the radio network speed. In such cases, reduce the DTE baud rate so that Integra-T buffers will not fill.

2.5.2 Data Forwarding Timer

The data forwarding timer can modify the timing between data blocks in a transmission to accommodate some RTU’s special timing requirements. Set to “normal” (15 ms) unless advised otherwise by technical support. Do not use “fast” (5 ms) timer below 2400 b/s.

2.5.3 Sending Break Signals

Integra-TR may be configured to send “break” signals, as required by some SCADA user protocols. A break signal is generated by holding TXD in the zero state for longer than one character time. Indication of a break signal is carried in a special data transmission to the remote station, which in turn generates its own output break signal.

At a port speed of 9600 b/s, the output break signal has a duration of 10 to 20 ms, regardless of the duration of the input break signal. These times are scaled proportionally for other baud rates. Integra-TR may also be set to ignore “break” signals in order to prevent spurious transmissions when terminal equipment is powered on and off.

2.5.4 COM Port Baud Rates

The COM port operates at standard baud rates from 300 – 19200 b/s. Baud rate is set using the Integra RSS and is independent of the network speed setting.

We recommend that the COM port baud rate be set to a speed not greater than the network speed. Setting a COM port baud rate higher than the network rate may result in data buffers filling, which in turn may cause Integra-TR to drop CTS. This could have detrimental effects on some protocols, particularly those that ignore CTS.

The COM port will support 7 or 8 data bits, one or two stop bits, and even, odd or no parity. Selection is made via Integra RSS. These parameters may be set differently on various Integra-T units without affecting their ability to communicate with each other.

2.5.5 Diagnostics

Online diagnostics may be included as part of an extended header at the beginning of each transmission. It may be enabled or disabled on a per-unit basis without affecting inter-communication. Reception of online diagnostics is always enabled.

Enabling this option adds about 5 ms delay at 9600 b/s (10 ms at 4800 b/s) to each transmission, but has no other effect on network operation.

Online diagnostics for all audible stations is delivered out at the Setup Port. An ASCII diagnostic output is also available. Diagnostic information is normally collected at the master station.

Offline diagnostics are sent upon receipt of a command from the Integra RDS, normally when the host application is stopped or taken offline. Since diagnostics transmissions are not under the control of the SCADA user protocol, temporary network disruption will occur if both are attempted simultaneously.

2.5.6 Addressing

Each Integra-TR is associated with three identification numbers (addresses):

ESN: The Electronic Serial Number is uniquely assigned to each Integra-TR at time of manufacture and cannot be changed. It is identical to the serial number printed on the label of the unit. Integra-T uses this number for identification only; it does not form part of the on-air protocol. The ESN of a remote unit may be viewed with the RDS by doing a *Remote GET*.

Short ID: The short ID (maximum value of 254) is used to identify Integra-TR for purposes of diagnostics (both online and offline), remote configuration and commands. The default value of the short ID (set at factory) is calculated from the ESN. This value may be changed via the Integra RSS. It is important that all stations within a communicating group have unique short IDs.

Station Type: This is a 1-bit value used to identify the station as a master or remote. See 2.5.7 below.

2.5.7 Station Type

On a simplex Integra-TR network, all remote stations can hear the master, and many remote stations can hear each other. Certain SCADA user protocols are designed with the assumption that remote stations **can not** hear the responses to polls made by other remote stations.

To allow operation with such protocols in simplex networks, Integra-TR has a simple addressing scheme. Stations may be designated as *master* or *remote*. This sets a flag in the header identifying the type of the originating station.

On the receive side, Integra-TR stations can be set to accept all data, or accept data only if it originates from a station **of the opposite type** (selective). This choice is made by setting *Data Delivery* to *selective* or *all* using the RSS.

2.6 Online Diagnostics

Online diagnostics, if enabled, are included with every data transmission. Online diagnostics do not interfere with normal network operation. The following information is gathered and delivered via the Setup port:

- Unit's "short ID"
- Inside case temperature: degrees C
- Supply voltage (B+): tenths of a volt
- Local received signal strength: dBm
- Remote received signal strength: dBm
- Forward power: tenths of a watt
- Reverse power: good / poor
- Receive quality: based on last 15 data blocks received.

2.6.1 Using an External Program for Online Diagnostics

The Setup port communicates with the RDS using a proprietary protocol that is not documented in this manual. However, if a terminal, or a PC running terminal software, is connected to the Setup port, online diagnostic information will be delivered in plain ASCII form.

For the purposes of the following discussion we will refer to the proprietary data format as RSS/RDS mode.

2.6.1.1 Initialization

When Integra-TR is powered on, it will attempt to establish a link with the RSS/RDS and select its output mode as follows:

1. If RTS is not exerted on the setup port, Integra-T will immediately switch to ASCII mode.
2. If RTS is exerted on the setup port, Integra-T will send an initialization message in RSS/RDS mode and wait for the proper response from the RSS or RDS.

- If there is no response, Integra-T will switch to ASCII mode.

The cleanest interface for a user program exists if the program initializes the PC serial port with RTS false. This will disable the RSS/RDS mode and only ASCII data will be output from the port.

2.6.1.2 Online Diagnostic String Format

In ASCII output mode, the setup port will output a one line diagnostic string each time the unit receives a transmission from another unit. No other data will be output. The string consists of a number of comma-delimited fields terminated by a carriage return. Each field is a constant length (with leading zeros if required), regardless of the value contained in the field, but the fields are not all the same length.

The field definitions are shown in the table below.

Name	Length	Description
Short ID	4	1 – 254
Temperature	3	Signed value in °C
B+	4	Tenths of a volt from 6.0 to 18.8V
Remote RSSI	4	Signal strength received by remote station
Local RSSI	4	Signal strength for this remote as received by local station
FWD power	4	Tenths of a watt.
Rev power	1	0 = good 1 = poor
RX quality	3	Number of good data blocks received in the last 15.
	3	Number of total data blocks detected, maximum 15.

Note: A data block is about 26 bytes long.

A typical diagnostic string, with its interpretation, is shown below:

0003,+28,13.1,-093,-088,4.7,1,015,015

Remote station # 3 reports that:

- its internal case temperature is +28°C,
- supply voltage is 13.1 VDC,
- it is receiving a signal of -93 dBm from the master,
- the master is receiving a signal of -88 dBm from station 003,
- the forward power is 4.7 watts,
- the reflected power is OK,
- 15 of the last 15 data blocks were received correctly.

2.6.2 Interpreting Diagnostic Results

Interpretation of the diagnostic results is similar for both online and offline diagnostics. Where differences exist, they will be noted in the text. For simplicity, we continue to assume that diagnostics are being collected at the master station.

2.6.2.1 Short ID

Online diagnostic data is identified by the Short ID of the unit. Users should make sure that all units in a communicating group have unique Short IDs.

2.6.2.2 Temperature

Internal case temperature of sending unit. This is a 3-digit signed value in degrees C. This value should remain within the limits of -30°C to +60°C.

2.6.2.3 B+ Voltage

Current value of supply voltage. This is a 4 digit signed value in volts, e.g. a value of 13.3 indicates 13.3 VDC. This value should remain within the limits of 10-16 VDC.

2.6.2.4 Remote RSSI

Displays the strength of the last valid data signal received by a reporting remote unit.

In a polling type network, the last signal usually originates from the polling master unit.

For the master itself, the last signal received is that of the remote that answered the previous poll.

This is a 4-digit value, including the leading minus sign, expressed in dBm with a typical accuracy of +/- 2dB. For example, a value of -090 indicates a signal strength of -90 dBm.

2.6.2.5 Local RSSI

Displays the strength of the last valid data signal received by the connected Integra-TR unit. The format described in the *Remote RSSI* section above applies.

2.6.2.6 Interpreting RSSI Readings

Typical values of RSSI will be in the range of -110 dBm to -60 dBm, with higher values (i.e. less negative values) indicating a stronger signal.

Reliability of data reception depends largely on signal strength. Good design practice calls for a minimum 30 dB “fade margin”, based on a threshold reception level of -107 dBm (1 uV) at speed of 9600 b/s. Experience indicates that this will give about 99.5% reliability.

Some representative performance values for 9600 b/s operation are given below. These values assume that the units are correctly aligned and installed in a quiet location. Environments with high electrical or RF noise levels will require an increase in the numbers shown to achieve a given level of reliability.

-100 dBm. Approximately 50% reliability.
Fading may cause frequent data loss.

-90 dBm. Approximately 90% reliability. Fading will cause occasional data loss.

-80 dBm. Approximately 99% reliability. Reasonable tolerance to most fading.

-70 dBm. Approximately 99.9% reliability with high tolerance to fading.

If RSSI values drops seasonally, the most likely cause is tree foliage, which can interfere with radio transmissions during the spring and summer.

2.6.2.7 Forward Power

Approximate measure of transmit power. This is a 4 digit value in watts rounded to the nearest

tenth. **Note that this is an approximate value that should be used for trend monitoring only.** It does not compare in accuracy with values obtained by a standard wattmeter.

2.6.2.8 Interpreting Power Readings

The values returned are approximate and should not be regarded as an absolute indicator of performance. For example, a unit that shows a forward power of 4.5 watts may actually measure at 5.0 watts on a lab quality wattmeter. For this reason, these values should not be used to indicate that a unit is out of spec or to compare one unit to another.

However, the values returned are consistent over time for any given unit. If statistics are kept on a unit per unit basis, changes in forward or reflected power are significant.

Therefore, the following conditions are worthy of investigation.

1. Forward power output drops or rises by more than 10% from its established value. Reflected power remains low.
2. This indicates that the transmitter may need alignment or that a component may be in need of replacement.
3. Forward power output drops by more than 10% from its established value. Reflected power shows an increase.

This indicates a possible antenna or feedline problem that affects SWR (Standing Wave Ratio).

2.6.2.9 Reverse Power

Approximate measure of reverse (reflected) power. The value is returned differently for on-line and offline diagnostics:

Online: The value returned is 0 if reverse power is within acceptable limits, 1 if reverse power is too high. The threshold is set to approximately 1/4 of the forward power value.

Offline: Value is in watts to the nearest tenth. This value is intended as an indication of antenna problems and will normally be used for trend monitoring. Ideally it should close to be

zero, but values up to about 15% of Forward Power may be encountered in properly operating systems.

2.6.2.10 Reverse Power and SWR

A reverse power reading above zero is an indication that the antenna, feedline or connectors are damaged, corroded or improperly tuned. This creates *standing waves* that are reported as a Standing Wave Ratio (SWR).

The table below, based on a forward power of 5 watts (it may be scaled for lower power settings) gives guidelines to interpreting these figures:

Table 4: SWR / Rev Pwr

SWR	Rev Pwr	Significance
1:1	0	ideal situation
1.5:1	0.2	normal operation
2:1	0.6	should be investigated
3:1 or greater	1.25 or greater	defective antenna, feedline or connectors.

In the case that the values returned by the built-in diagnostics seem to indicate a problem, we recommend verification by means of proper radio shop equipment.

2.6.2.11 RX Quality Indicator

This is the number of good received data transmissions out of the last 15.

The receive quality indicator value returned by any remote unit to the master station is an indication of the reception quality on the outbound path.

If the master station is monitored, either from a remote station or by using a local GET STATS, users should note that the receive quality indicator thus returned is a composite value which represents the average reception from the last 15 remotes. Any significant drop in the receive quality indicator returned by the master station is therefore likely to indicate a problem with the

master station receiver itself, rather than any one remote station.

2.7 Offline Diagnostics

Offline diagnostics are returned in response to a specific request to a particular station. Requests are issued using the Integra RDS, either locally or remotely from another station. This may cause slight temporary network disruption.

The diagnostic information available is similar to that available from *online diagnostics* with the following additions:

Demodulated signal voltage: peak-to-peak
 Analog 1 input voltage: 0 – 10 V in tenths
 Analog 2 input voltage: 0 – 10 V in tenths
 Reverse power: tenths of a watt rather than a good / poor flag.

Note: Analog 1 and 2 have 8 bits of resolution.

2.8 Low Power Operation

To accommodate users, who operate sites with limited available power, Integra-TR offers the following power saving features:

1. Reduced transmit power
2. Suspend mode
3. Sleep mode

2.8.1 Reduced Transmit Power

Integra-TR's transmitter is type-approved for power levels less than 5 watts. Simply select the desired power setting using the Integra RSS. Reducing transmitter output power from 5 watts to 1 watt will reduce maximum current consumption by approximately 0.5A to 1.0 A depending on radio model.

2.8.2 Suspend Mode

Note: as long as the RTS is asserted (on any port), the unit will be kept awake.

In Suspend mode, **remote** stations remain in "low power consumption mode" (nominal 7 mA), waking up periodically for about 100 ms to check the presence of a carrier.

If a carrier is present, the unit will remain awake for a period of time set by the *Activity timeout*.

At the end of that time, if a carrier is present or if data has been decoded, the *Activity timeout* is restarted.

If there is no carrier or no data was decoded, the unit goes into "low power consumption mode" for the duration of the *Suspend period*.

The *Suspend period* can be set via the RSS to any value between 50 to 12000 ms in 50 ms steps. Setting a value of 0 disables the Suspend mode.

The *Activity timeout* can be set via the RSS to any value between 1 and 255 seconds.

The same *Activity timeout* and *Suspend period* values must be set for both master and remote stations.

Master stations always remain awake. To make sure those suspended remotes have time to wake up for outbound master data transmission, the master unit will automatically extend its start-of-transmission synchronization time to slightly exceed that of the remote stations' *Suspend period*. This is done only for the first transmission.

If the subsequent master transmissions begin within the *Activity timeout* setting, it will then begin with a normal start-of-transmission synchronization time.

If the delay between master transmissions is more than the *Activity timeout*, the next transmission will be extended.

2.8.3 Sleep Mode

In this mode, the unit is always in low power consumption (nominal 7 mA). Only asserting RTS on the COM or the SETUP ports can wake-up the unit. When the unit is sleeping, it cannot detect the presence of a carrier. This mode can be selected from the RSS.

The unit will be ready to receive a carrier and decode data within 45 to 65 ms (depending on radio model and temperature) after wake-up.

2.8.4 Remote Unit Wake-up by DTE

A Remote Terminal Unit (RTU) connected at an Integra-TR (configured as remote) can be awakened by raising either RTS inputs.

DOX mode: either COM or SETUP ports RTS can be used for wake-up. Data from DTE cannot wake-up the unit.

RTS mode: the SETUP port RTS can be used for wake-up without causing transmission.

2.9 Transmitter Timeout

Integra-TR is equipped with a 30-second transmitter timeout (Tx Timeout) designed to protect both Integra-TR itself and the network in case a transmitter becomes "stuck" on the air.

Should this happen with a remote station, the master would be unable to hear some or all of the other remote stations (depending on relative

signal strength), seriously disrupting network operation.

The Tx Timeout is fixed at 30 seconds, and may be enabled or disabled using the Integra RSS. When active, the Tx Timeout disables the transmitter. The timer can be reset by cycling RTS off and back on again. In DOX mode the timer will reset at the next break in the data stream that exceeds the value set for the Data Forwarding Timer. In either case, a new transmission may begin immediately.

If your application software may occasionally output data for longer than 30 seconds, the TX TIMEOUT timer may be disabled. **Warning: Transmissions longer than 30 seconds may exceed the duty cycle rating of the transmitter and lead to shortened life or transmitter failure.**

However, for high-duty-cycle transmit applications, a fan is available as an option (contact your sales representative). For continuous-transmit application, the TX Timeout timer must be turned off (set to “disable”).

2.10 Optimizing Your System

Detailed system engineering is beyond the scope of this manual. However, there are some simple tips that can be used to optimize performance of a radio based SCADA or telemetry system.

Choose the best protocol. Some SCADA devices allow a choice of more than one operating protocol. In some cases, performance can be improved by selecting a different protocol. Your sales representative can advise you for many common types of equipment, or a simple trial and error process can be used to select the one that performs best.

Check timer settings. Polling protocols issue a poll, then wait a certain time for a response. Integra-T adds a short amount of delay to each poll and response (typically in the order of 60 to 70 ms). Timer settings that are too short may cause erroneous indication of missed polls, in which case the application may retry or continue to cycle, ignoring the missed station. In this case, the response may collide with the next poll, further increasing errors. Setting an adequate timer margin will avoid problems and maximize performance.

Avoid flow control. Set the Com port baud rate to a value less than or equal to the radio network speed (4800, 9600 or 19200 b/s). In a polling system, this will prevent buffer overflow with possible missed transmissions. If the port baud rate *must* be set higher than the radio network speed, you may have to limit message length to prevent possible buffer overflow. Integra-T will always exert a flow control signal (CTS dropped) if buffers are almost full, but not all DTE honor such signals.

Use the highest suitable port baud rate, without exceeding the radio network speed. Operating an RTU at 1200 b/s on a 9600 b/s network will increase data transmission delays and reduce system performance.

Evaluate the need for online diagnostics. Enabling online diagnostics increases delays by 5 to 10 ms (depending on speed). In critical applications, this extra delay can be eliminated by disabling online diagnostics. Offline diagnostics (diagnostics on request) remain available.

3. Maintenance adjustments

3.1 Overview and Maintenance intervals

This chapter outlines the basic adjustment procedures required upon initial installation and thereafter at annual maintenance intervals or whenever deterioration in performance indicates that adjustment may be required. Units are delivered from the factory properly aligned and tested on the frequencies specified at time of order. Adjustment beyond that described in this chapter is not required unless radio modules have been tampered with or repaired. In such cases, we recommend complete factory re-alignment, as special test jigs are required.

3.2 Intended Audience

This chapter is intended for use by installation and maintenance personnel.

3.3 Equipment Required

The adjustments described below require the following equipment:

1. 13.3 VDC / 5A regulated power supply.
2. Radio service monitor (IFR or equivalent).
3. Cable with SMA connector to connect Integra-T to the service monitor.
4. Integra Radio Service Software (RSS) kit.
5. A PC 486 or better to run the RSS.
6. Normal radio shop tools including alignment tools.

3.4 Test Point

For trouble shooting aid, there is one test point available at pin 4 of the power/analog connector (white wire). This demodulated signal measurement is half the voltage read at the RSSI bar graph.

Note: the RX-TP mode must be selected using the Integra RSS.

3.5 Basic Adjustments

Basic adjustments to be performed are:

1. Transmitter power output
2. Transmitter frequency
3. Transmitter deviation
4. Demodulated signal level
5. Carrier Sense

3.5.1 Preliminary Steps

Important Note: Before proceeding make sure that the service monitor has been calibrated recently and has warmed up for at least the time specified by its manufacturer. Some reported frequency and deviation problems have actually been erroneous indications from service monitors that have not adequately warmed up. This is particularly likely when field service is done during winter months.

1. Connect the Integra-TR's antenna connector to the input of the service monitor using a suitable length of 50-ohm cable. That input should be able to support at least 5 watts.
2. Connect Integra-TR to a suitable power supply and adjust the supply voltage to 13.3 volts (16 VDC maximum).
3. Using a suitable 9-conductor straight RS-232 cable, connect the unit's Setup port to the RS-232 port of a PC and run the Integra RSS program (INTRSS.exe) on the PC.
4. Press GET to get the configuration from the unit.
5. From the *Radio Settings* window, accessed by double-clicking the *Radio Settings* icon, set the frequency to be used for testing. Leave this window open and on top.
6. Follow the steps in the Table 4.

3.5.2 After Adjustments are Done

Adjustments made using the RSS are temporary and must be made permanent as follows:

1. After all adjustments are completed satisfactorily, press "PUT" to save the changes permanently to the unit.
2. Press *Station Reset* to activate all configuration changes.

Table 5: Tests and adjustments half and full channel units

STEP	ACTION	EXPECTED RESULTS	MEASURE WITH	IF NOT?
1	Output Power Press <i>TX Unmod</i>	5 W ¹ +10%, -20%	Service monitor set to read power	Adjust using the RSS <i>Power Out</i> setting (255 is the maximum) or, Refer to factory tech support.
2	Frequency Error Press <i>TX Unmod</i>	Within ± 300 Hz	Service monitor set to read frequency	Adjust using the RSS <i>Freq Warp</i> setting. (Typical adjustment range is 1.5KHz) If found outside limits, user is to call factory technical support.
3	Deviation Press <i>TX</i> tone For any bit rate speeds selected	Tol. +5%, -10% For Full channel: ±4.0 kHz For Half channel: ±2.5 kHz	Service monitor set to read deviation with mid (15-30 kHz) IF filter.	Adjust using the RSS <i>Deviation</i> setting if required.
4	Set the service monitor to generate a -80 dBm signal on the selected receive frequency. The signal should be modulated with a 1.0 kHz tone at ± 3 kHz deviation. Set service monitor IF filter to mid (15-30 kHz), no audio filter.			
5	Demodulated Audio Press <i>CHK</i> For any bit rate speeds selected: <ul style="list-style-type: none"> For Full channel unit, set generator deviation to ±4.0 kHz For Half channel unit, set generator deviation to ±2.5 kHz. 	2.0 Vpp ± 0.2	Bar graph in <i>Radio Settings</i> window.	Adjust using <i>RXA adjust</i> setting if required.
6	12 dB SINAD Set service monitor IF filter to mid (15-30 kHz). <ul style="list-style-type: none"> For Full channel unit, set deviation to ±3 kHz. For Half channel unit, set deviation to ±1.5 KHz 	≤ 0.5μV ²	Service monitor set for SINAD.	Refer to factory tech support Note: Connect to the test audio pin 4 of the power/analog connector (white lead) ³
7	Distortion Set service monitor IF filter to mid (15-30 kHz).	< 3%	Service monitor set for DISTORTION.	Refer to factory tech support. Note: Connect to the test audio pin 4 of the power/analog connector (white lead) ³

¹ (unless you have set a lower value). Note that readings less than 5 watts may be due to losses in the cables used for testing. Check also your wattmeter frequency calibration curve. Do not be too ready to condemn the transmitter.

² if a psophometrically weighted filter is available on the service monitor, use 0.35 μV.

³ in the RSS' *Analog connector window*, Check the *RX-TP* box. (Accessed by double-clicking the *Analog Connector* icon).

4. Circuit Description

4.1 Overview

This chapter describes the circuit operation of the logic board.

4.2 Intended Audience

This chapter is intended for use by engineering and service personnel.

4.3 Circuit Description

Refer to Figure 12 when reading the following sections.

4.3.1 Microprocessor Circuit

For the microprocessor section, two Z84015 CMOS low power Intelligent Peripheral Controllers are used. Each IPC is an 8-bit microprocessor integrated with CTC, SIO, PIO Clock Generator Controller and Watch Dog Timer. One of the Z84015s (U17) is used in the normal mode. The other Z84015 (U21) is used in the evaluation mode and as such only the CTC, SIO and PIO section are used. The CPU section is disabled.

The first Z84015 Clock Generator uses a 19.6608 MHz crystal which provides a CPU clock rate of 9.8304 MHz for both Z84015s. The 9.8304 MHz clock is further divided by 2 to feed all 8 CTC (4 in each Z84015).

The 64K memory space of the Z84015 is divided into two blocks of 32k each. The lower 32K is used for the firmware program and the upper 32K by the CMOS RAM (U18). The memory IC used for the program is a CMOS FLASH (U22) with 1024 sectors of 128 bytes each.

The dual Z84015 circuit provides up to 8 CTC, 4 SIO (Serial I/O) and 32 PIO (Parallel Input/Output) lines.

The CPU also provides the clock for the CPLD modem.

4.3.2 RS232

The RS232 IC (U15) is used to interface the application DE-9 connector to the SIO_B section of U17, and the set-up DE-9 connector to the SIO_A section of U21. When in sleep mode, two receivers remain enabled, this is needed for fast wakeup.

4.3.3 MODEM

The modem section is used to interface the serial digital data to the transceiver.

The CPLD modem IC (U16) with a programmable Raise-Cosine filter (U10), operates in DRCMSK mode at 4800, 9600 and 19200 bits/sec. It incorporates a 7-bit hardware scrambler and uses Differential (NRZI) encoding in DRCMSK mode to minimize data pattern-sensitivity. Electronic potentiometer U5B (E-Pot), controlled by CPU U17, is used to set the transmitter deviation by amplitude adjustment of the baseband signal. Electronic potentiometer U5C is also provided to adjust the frequency of the RF carrier.

4.3.4 TRANSMIT & RECEIVE DATA

Transmit Data from the RS-232 port is level-shifted to TTL by U15, then passed through the CPU for further processing and conversion from asynchronous to synchronous format. The CPLD modem, U16 takes the digital data stream from SIO-A of the CPU and synthesizes to the constant-amplitude analog baseband signal, which is filtered by U10, buffered by U9B then applied to radio module TXA at P1-6.

Received signals are applied to the RXA pin on P1-13 amplified by U3A, whose gain is set by the electronic potentiometer U5D, and then filtered by U10. The same filter circuit is used for transmission and reception: two analog multiplexer/demultiplexer gates (U8A and B) controlled by TX_EN line are used for sharing. The filter U10 cut-off frequency is programmable by the CPLD, based on the data rate. The analog signal is then buffered by U1D and fed to Peak Detectors U3C, U3D and U3B, and to the slicer circuit U1C via U1B. The raw data is then passed to the CPLD modem U16 for descrambling and receive clock recovery. The resulting

synchronous bit stream is then fed to CPU, SIO-A for further processing and conversion to asynchronous format before delivery to the RS-232 driver and to the user port.

4.3.5 Integra-R A/D and DIGIPOT

An 8 channel, 8-bit successive approximation A/D converter, type ADC0838 (U4), is interfaced to CPU (U17) and Peripheral (U21). CH0 and CH1 are connected to the positive and negative peak detector of the modem section. The software can thus read the positive or negative value of an RX signal, or using the differential mode, the actual peak-to-peak RX signal value.

CH3 is used to measure the radio RSSI signal which was amplified by U7A.

CH4 is connected to the radio diagnostic signal (P3-14). This pin is used to output an analog signal corresponding to the power output and the reflected signal.

CH5 is connected to U6 (LM50), a temperature sensor with a -40 to +125°C range.

CH6 is used to read the SWB+ voltage after proper scaling into the 0-5 V range.

CH7 and CH8 are connected to EXT SIGNAL 1 and 2. A 2:1 divider and protection circuit is inserted between both external signals and the A/D.

The EXTERNAL SIGNAL 1 and 2 pins are also connected to U21 at PB6 and PB7 through transistors Q3 and Q4, and thus can be used for ANALOG INPUT or DIGITAL OUTPUT (available on some Integra versions).

EXT_SIGNAL2 is also connected to the rx test point RX-TP through U8A (74HC4066). Under software control the RX-TP (scaled down by 2) is thus available on the power connector for trouble-shooting purposes.

A 4 channel digital potentiometer type (U5) is used to adjust the RX SIGNAL, TX MODULATION, CARRIER FREQUENCY and CARRIER DETECT THRESHOLD.

An 8 channel, 8-bit successive approximation A/D converter, type AD0838 (U9), is interfaced to CPU (U18) and Peripheral (U20).

U19 generates a power-on reset for the CPU and U6 is a temperature sensor used by the firmware to compensate for variations in RSSI.

The RSSI signal from the transceiver is amplified and filtered by U7A, it is then compared to a threshold value set by a digital potentiometer (U5A). The output of the comparator (U7B) is used to change the hold time of both peak detectors at the beginning of the receive packet.

4.3.6 Wake-Up Circuit

The wake-up circuit for Integra-R consists of a 50 ms monostable circuit that is triggered by the rising edge of a SLEEP signal from the CPU (U17). The falling edge of this 50 ms pulse (end of pulse) is connected to the \NMI of the CPU and thus will wake up the CPU from SLEEP mode after 50 ms.

When exiting SLEEP mode on a \NMI, the CPU firmware will increment a counter, then return to SLEEP until it reaches a limit set by a software parameter. When the programmed count is reached the CPU will wake up the radio and the RS232 driver, program the synthesizer, and watch for channel activity.

While in sleep mode (during the 50 ms pulse) an active RTS from either communication port will reset (terminate) the 50 ms pulse so that its falling edge will restart the CPU immediately.

The CPU will check to see if either RTS signal is valid each time it is restarted by the \NMI. The firmware will only start the sleep timer after checking that all "wake-up" inputs are inactive.

4.3.7 Power Supply

The 13.3 volt DC power input is protected by a 3 amp fuse and reverse protected by a diode. A 5 volt, low voltage regulator (U12) is used to power all digital functions and another 5 volt, low voltage regulator is used to control the analog +5V_SW voltage in the sleep mode.

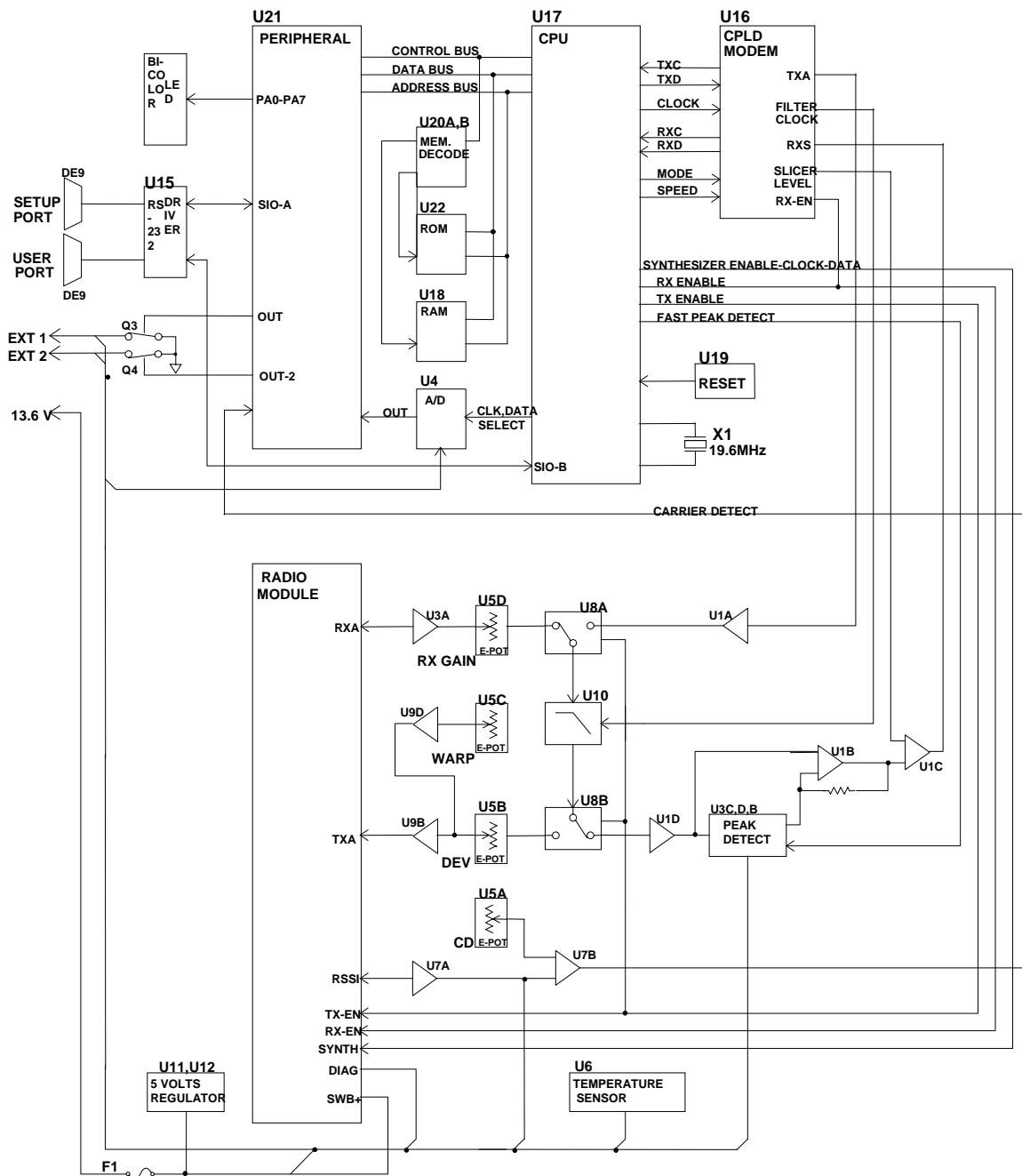

Figure 12 - Logic Board Block Diagram

Specifications

GENERAL

	VHF	UHF	900 MHz
Frequency	132 - 174 MHz	403 - 512 MHz	928 - 960 MHz
Channels	One channel. Frequency may be set locally or remotely.		
Channel spacing	30 kHz	25 kHz	25 kHz
Operating temperature	-30°C to +60°C		
Supply voltage	10 - 16 VDC maximum (nominal 13.3 VDC) Fuse protected input (internal surface mount 3A fuse: not field replaceable), Input is also protected against reverse voltage.		
RX Current drain at 13.3 VDC	< 170 mA (with a terminal connected to Integra-T COM port)		
TX Current drain at 13.3 VDC	<1.8 A	< 2.0 A	< 2.5 A
Low power mode current drain	7 mA (nominal)		
Cold start ¹	4 sec (typical)		
Warm start RX ²	45 to 60 msec (depending on radio model and temperature)		
Warm start TX ³	55 to 70 msec (depending on radio model and temperature)		
TX turnon time ⁴	15 ms typical		
RX/TX bandwidth, without tuning	18 MHz (132 - 150) 24 MHz (150 - 174)	16 MHz except 20 MHz (450 - 470)	32 MHz
Nominal Dimensions	4.5" W x 2.2" H x 4.75" D (11.4 x 5.6 x 12.1 cm)		

RECEIVER

	VHF	UHF	900 MHz
Sensitivity	0.35 μ V for 12 dB SINAD *		
Selectivity (25 or 30 kHz)	75 dB typical 70 dB minimum		72 dB typical 65 dB minimum
Selectivity (12.5 or 15 kHz)	65 dB typical 60 dB minimum		63 dB typical 60 dB minimum
Intermodulation	75 dB typical 70 dB minimum		72 dB typical 70 dB minimum
Spurious rejection	75 dB typical 70 dB minimum		75 dB typical 70 dB minimum
FM hum & noise	-48 dB typical -45 dB max (30 kHz)	-48 dB typical -45 dB max (25 kHz)	-43 dB typical -40 dB max (25 kHz)
Conducted spurious	< -57 dBm		

* psophometrically weighted

TRANSMITTER

	VHF	UHF	900 MHz
RF power output	1 to 5 watts, software adjustable		
Spurious and harmonics	-63 dBc (-26 dBm) typ -57 dBc (-20 dBm) max	-75 dBc (-38 dBm) typ -63 dBc (-26 dBm) max	-75 dBc (-38 dBm) typ -57 dBc (-20 dBm) max
Frequency stability	2.5 PPM	1.5 PPM	1.5 PPM
FM hum and noise	-50 dB typical (30 kHz) -45 dB max (30 kHz)	-50 dB typical (25 kHz) -45 dB max (25 kHz)	-50 dB typical (25 kHz) -40 dB (max (25 kHz)
Attack time	< 7 ms		

TX Duty cycle	50%, max TX time 30 seconds 100%, unlimited TX time with the cooling fan option
---------------	--

¹ Cold start: This is the time from when DC power is applied, until the unit is fully ready to receive or transmit data.

² Warm start RX: In low power modes (sleep or suspend), this is the Integra-T wake-up time for full receiver recovery.

³ Warm start TX: In low power modes (sleep or suspend), this is the Integra-T wake-up time for full transceiver operation.

⁴ TX turnon time: This is the typical RX to TX switching time for stable transmission.

MODEM / LOGIC

Operation	Simplex/half duplex
Data bit rates	Full Channel: 4800 b/s, 9600 b/s and 19200 b/s Half Channel: 4800 b/s, 9600 b/s
Modulation type	DRCMSK (Differential Raise-Cosine Minimum Shift Keying)
RTS/CTS delay (RTS mode)	4 ms
Addressing	8 bit station address, 1 bit station type (master, remote)
Bit error rate (BER)	better than 1×10^{-6} at 1.0 μ V (based on "block error rate") @ 9600 b/s (Full Ch.)

COM PORT

Interface	EIA RS-232C
Data rate	300 - 19200 b/s
Protocol	Transparent, 7 or 8 data bits, 1 or 2 stop bits, even, odd or no parity
Transmit control	RTS or DOX (data operated transmit)

SETUP/DIAG PORT

Data format	Proprietary binary for setup, ASCII for diags
Data rate	9600 b/s

ANALOG INPUTS

Interface	Two inputs, 0 - 10 VDC, 8 bits. May be read only via Offline diagnostics. Absolute maximum input voltage < 20 Vdc. Inputs are reverse-voltage protected.
-----------	---

DISPLAY

4 two color status LEDs	RUN/PWR, CS/SYN, RX/TX, RD/TD
-------------------------	-------------------------------

CONNECTORS

RF	SMA female
COM	DE-9F
SETUP/DIAG	DE-9F
Power / Analog	Snap & lock 4-pin DC power jack

DIAGNOSTICS

Online	Short ID, temperature, B+ voltage, local RSSI, remote RSSI, fwd and rev power, RX quality
Offline	As for Online plus: demodulated signal voltage, analog input levels

FCC / IC CERTIFICATIONS

	FCC (Pending)	IC (DOC)
VHF	EOTMUA5R (19K4F1D)	Pending (16K0F1D)
UHF	EOTMUB5R (19K4F1D)	Pending (16K0F1D)
900 MHz	EOTMUC5R (16K6F1D) (9K80F1D)	Pending (16K6F1D) (16K0F1D) (9K80F1D)

INDEX

A

addressing	9
adjustments	
equipment required	15
analog inputs	7

B

break signals.....	8
--------------------	---

C

characteristics.....	1
circuit description.....	17
COM port	
baud rates.....	8
commands, remote	3
configuration	1
connections	3

D

diagnostics.....	3, 8
interpretation.....	10
offline	12
online	9
online string format.....	10
using an external program.....	9
DOX mode	8
DTE connections.....	5

E

ESN	9
-----------	---

F

firmware upgrades.....	3
------------------------	---

L

LEDs	5
------------	---

M

master.....	9
-------------	---

O

optimizing performance	14
------------------------------	----

P

point to point.....	4
point–multipoint.....	4
power connector	7
power saving	13

R

range (distance).....	3
remote	9
RS-232 port.....	6
RTS mode	8

S

setup port.....	6
short address.....	9
signal quality	12
sleep mode	13
station type	9

T

tail circuit	4
--------------------	---