

Annex B: Schematics

RULE PART NUMBER: 2.1033 (c)(10)

Contents

Integra R Modem/loaderpag 2-5
DL3422 Transceiver.....pag 6

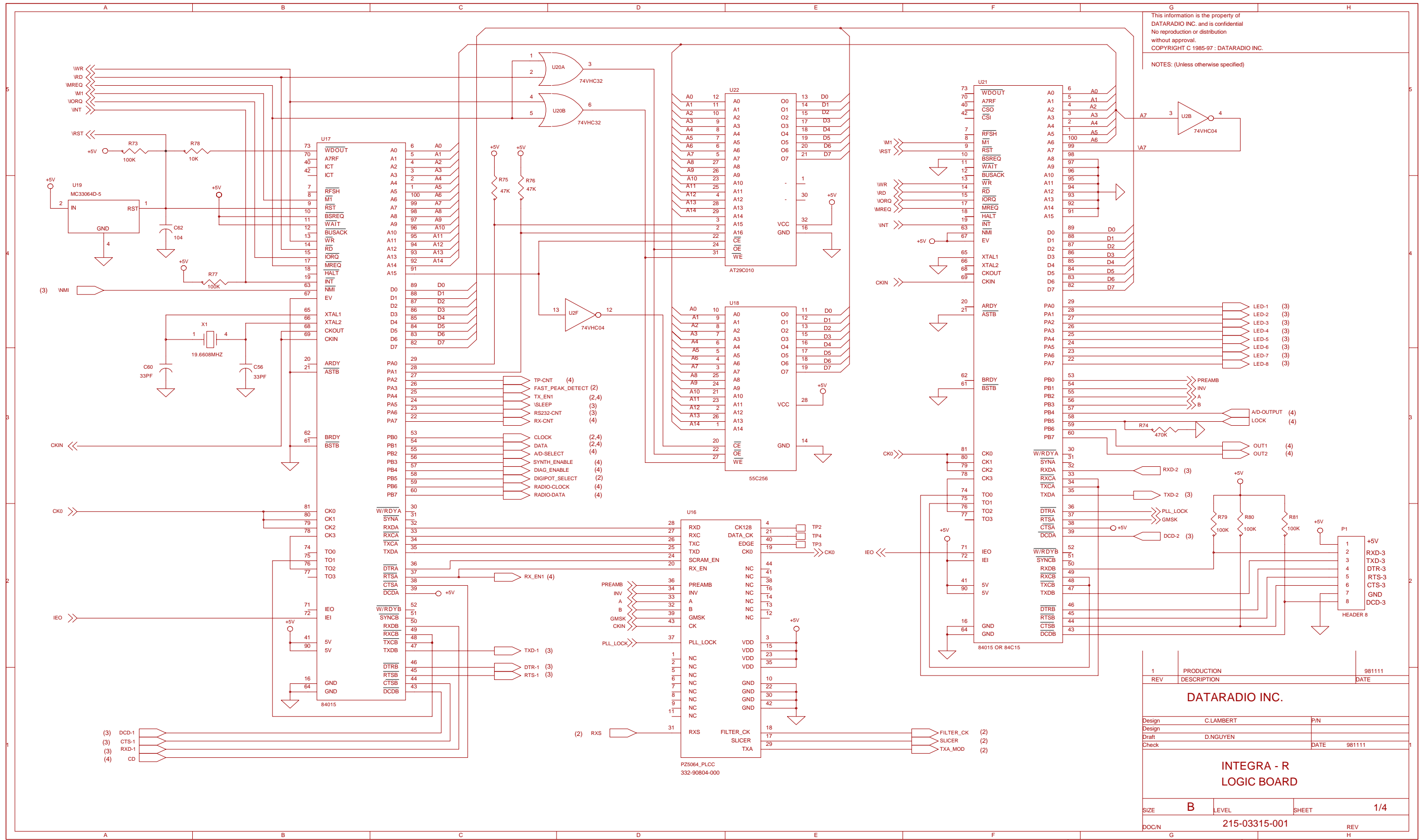

This information is the property of DATARADIO INC. and is confidential. No reproduction or distribution without approval. COPYRIGHT C 1985-97 : DATARADIO INC.

NOTES: (Unless otherwise specified)

1	PRODUCTION	981111
REV	DESCRIPTION	DATE
DATARADIO INC.		
Design	C.LAMBERT	PIN
Design		
Draft	D.NGUYEN	DATE
Check		981111
INTEGRA - R LOGIC BOARD		
SIZE	B	SHEET
	LEVEL	1/4
DOC/N 215-03315-001		
	REV	

This information is the property of DATARADIO INC. and is confidential. No reproduction or distribution without approval. COPYRIGHT C 1985-97 : DATARADIO INC.

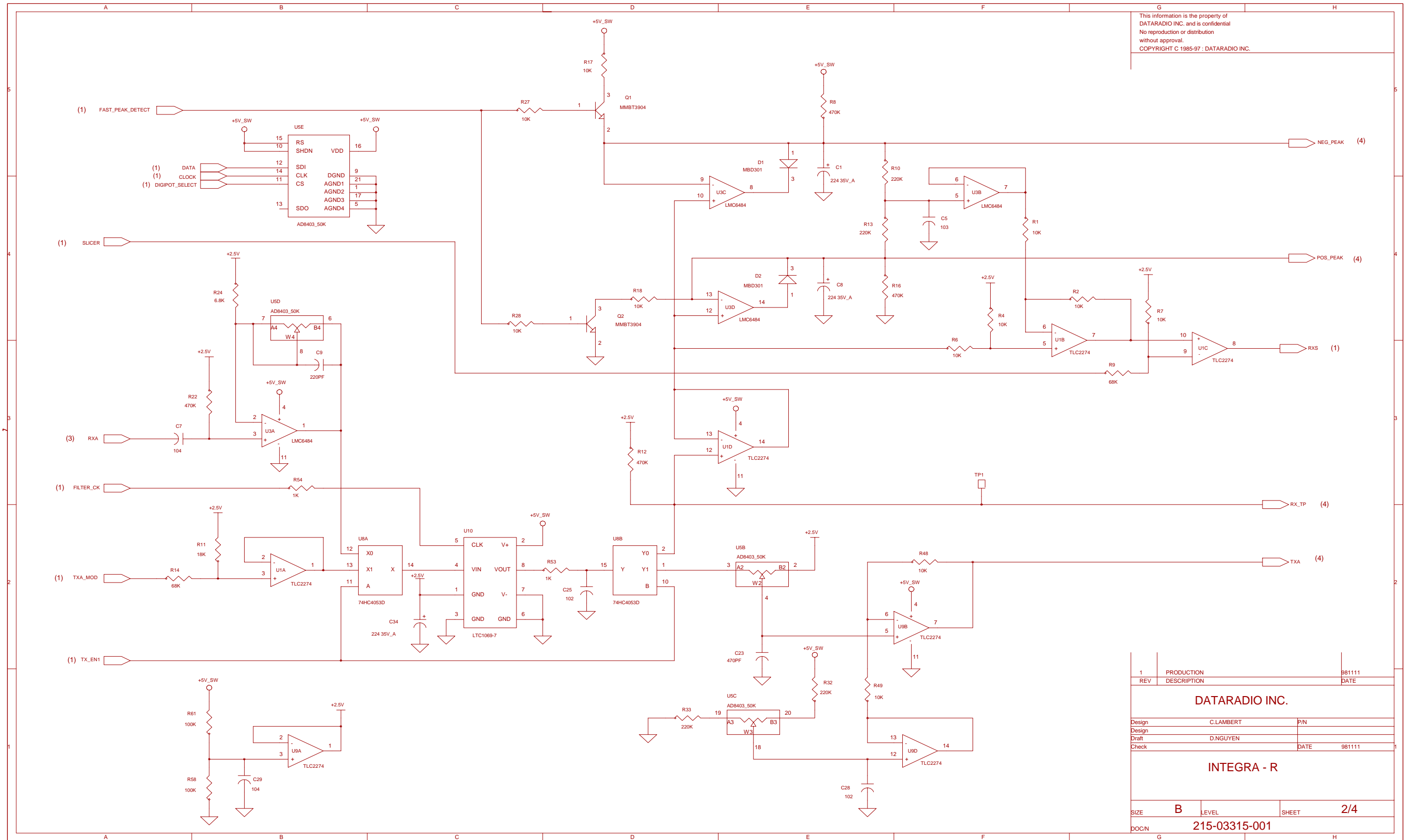

1	PRODUCTION	981111
REV	DESCRIPTION	DATE
DATARADIO INC.		
Design	C.LAMBERT	P/N
Design		
Draft	D.NGUYEN	
Check		DATE 981111
INTEGRA - R		
SIZE	B	SHEET 2/4
DOC/N	215-03315-001	

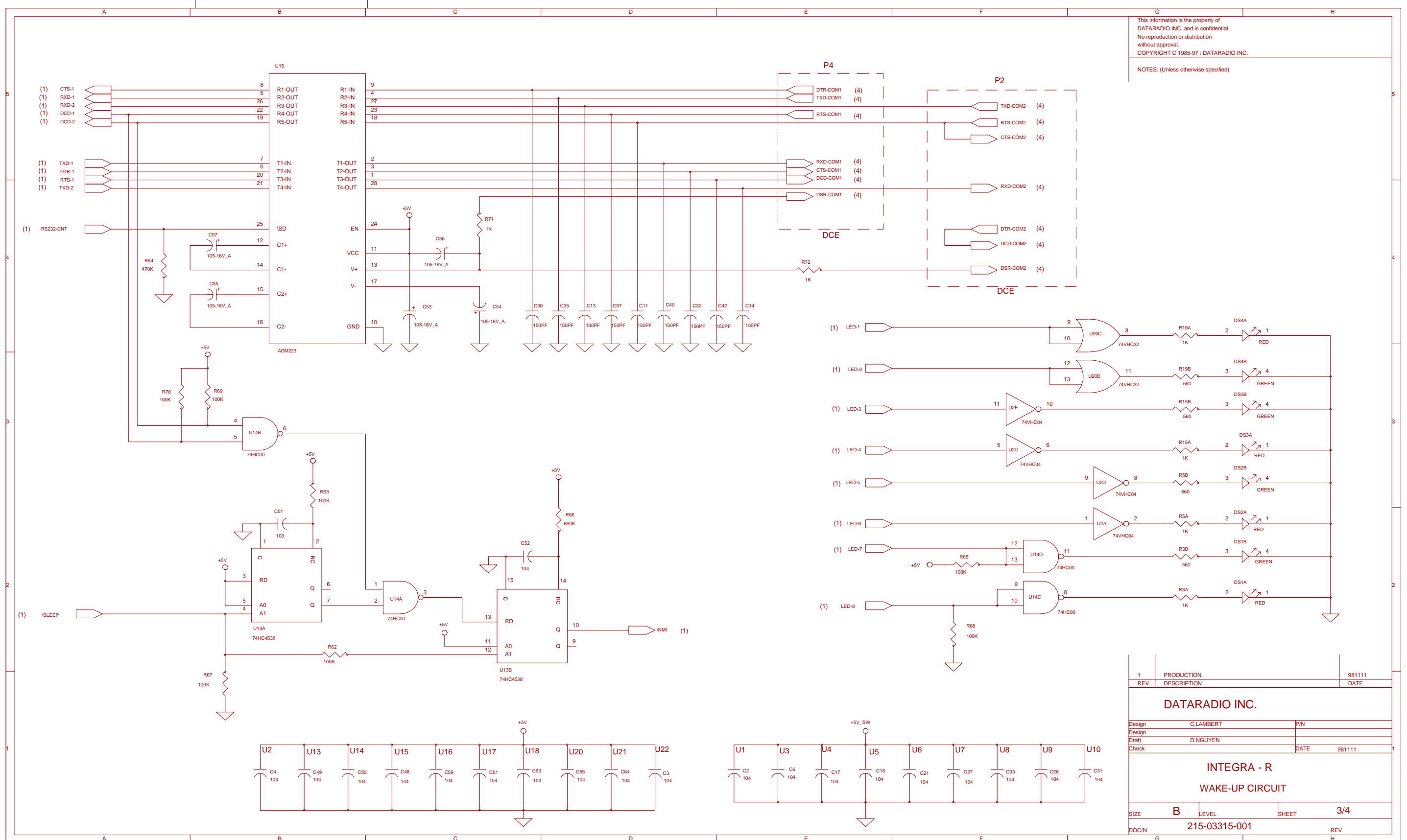

This information is the property of DATARADIO INC. and is confidential. No reproduction or distribution without approval. COPYRIGHT C 1985-97 : DATARADIO INC.

NOTES: (Unless otherwise specified)

1	PRODUCTION	981111
REV	DESCRIPTION	DATE
DATARADIO INC.		
Design	C.LAMBERT	P/N
Design		
Draft	D.NGUYEN	
Check		DATE 981111
INTEGRA - R		
WAKE-UP CIRCUIT		
SIZE	B	SHEET 3/4
DOC/N	215-03315-001	REV

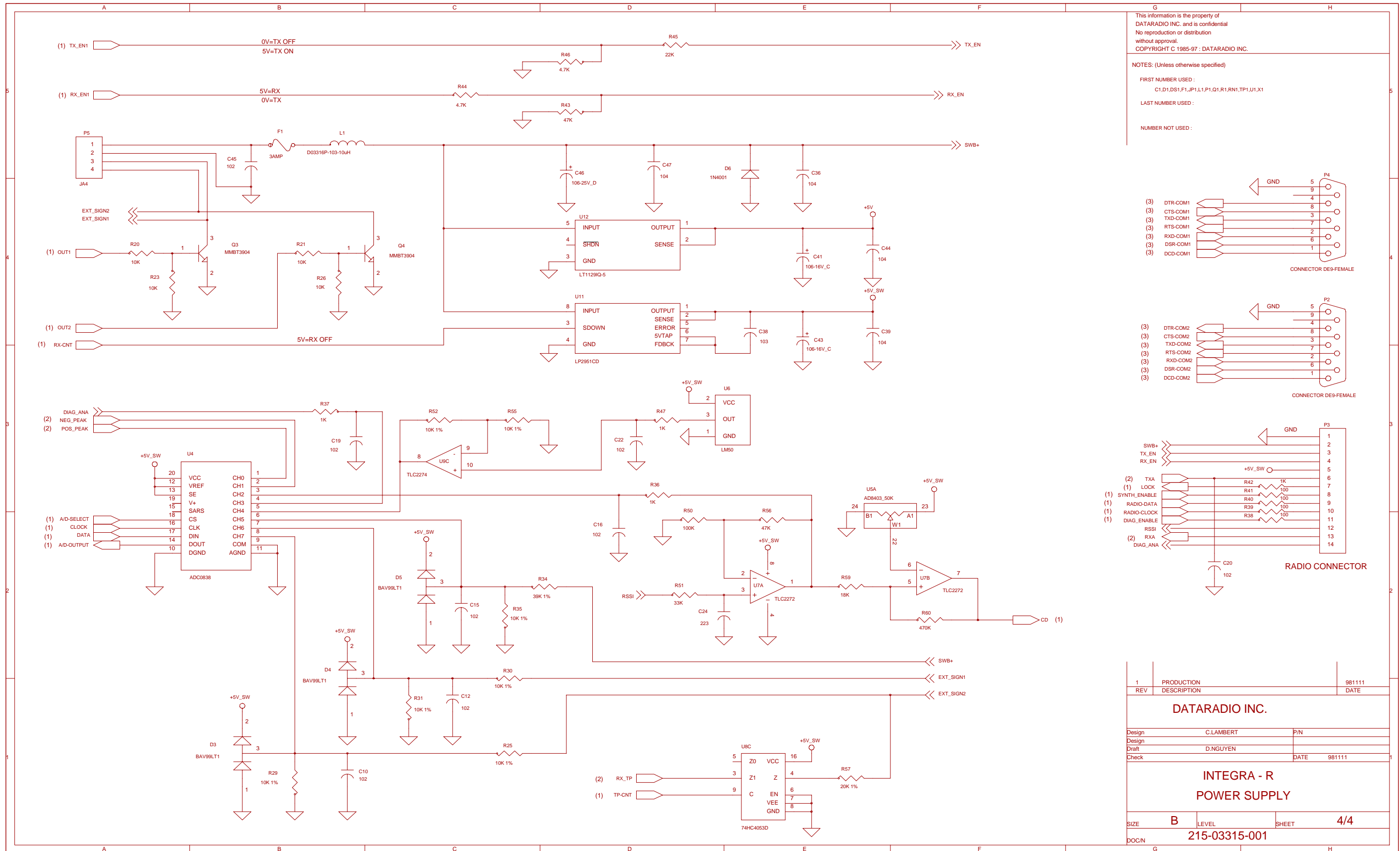

This information is the property of DATARADIO INC. and is confidential. No reproduction or distribution without approval. COPYRIGHT C 1985-97 : DATARADIO INC.

NOTES: (Unless otherwise specified)
 FIRST NUMBER USED : C1,D1,DS1,F1,JP1,L1,P1,Q1,R1,RN1,TP1,U1,X1
 LAST NUMBER USED :
 NUMBER NOT USED :

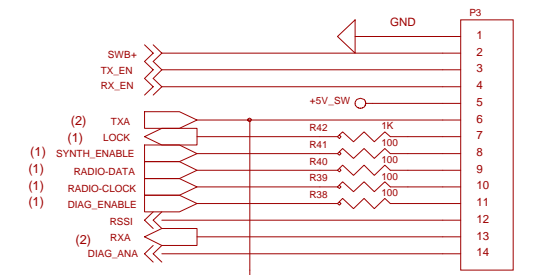
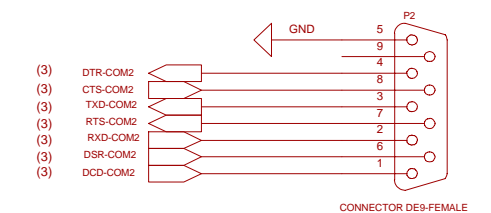
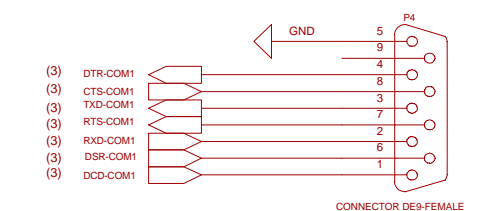

1	PRODUCTION	981111
REV	DESCRIPTION	DATE
DATARADIO INC.		
Design	C.LAMBERT	P/N
Design		
Draft	D.NGUYEN	
Check		DATE 981111
INTEGRA - R POWER SUPPLY		
SIZE B	LEVEL	SHEET 4/4
DOC/N 215-03315-001		

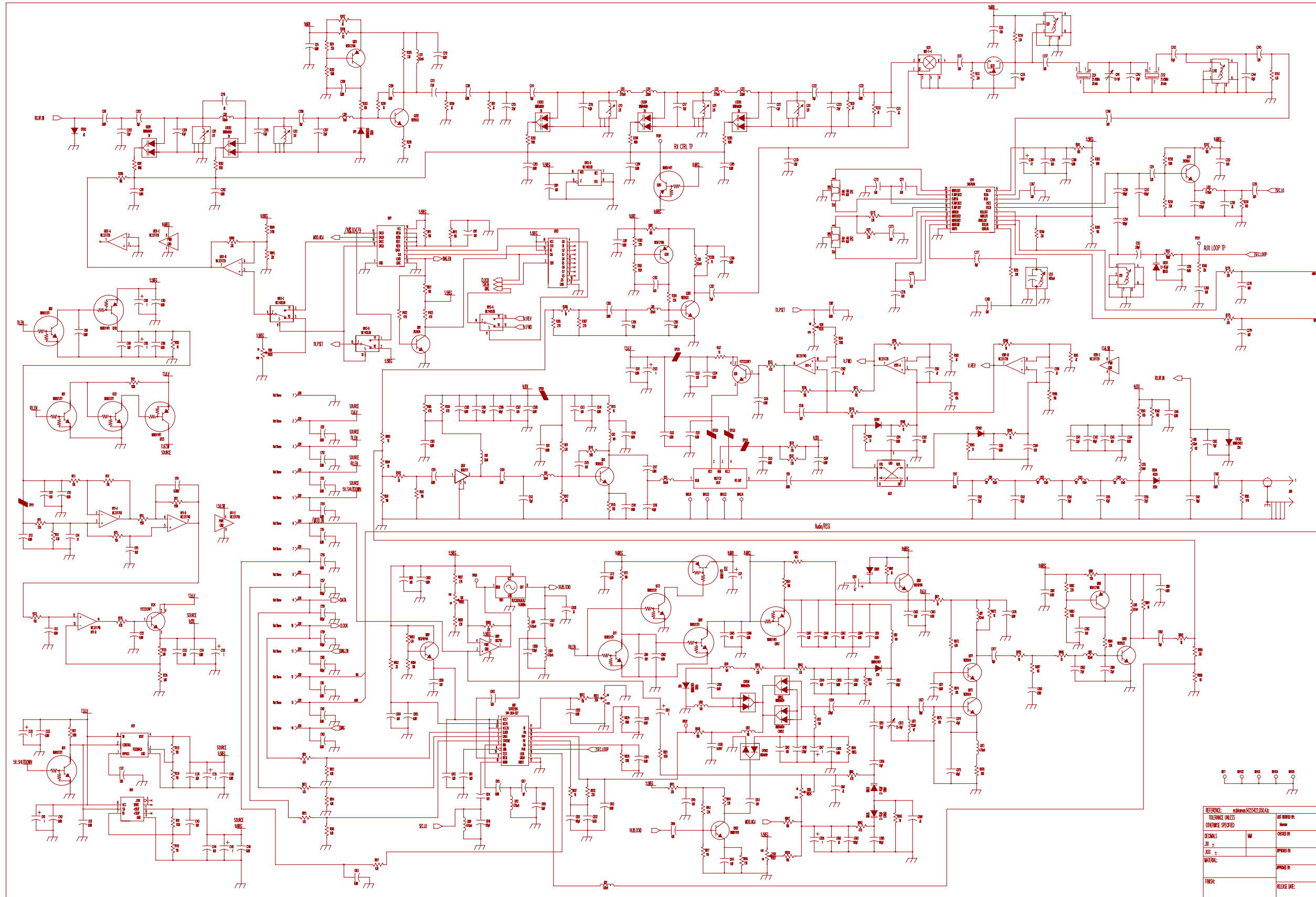

D- 025-3422-050

REVISIONS

COMPANY CONFIDENTIAL

REFERENCE: McM3024-0241-0241a	DESIGNED BY: JWK	DATE: 4/2/78	 <small>Johnson A Johnson Company</small> Johnson <small>Johnson Technology Corporation 200 West Main Street Riverside, CA 92507-0001</small>
TOLERANCE UNLESS OTHERWISE SPECIFIED	CHECKED BY: JWK	DATE: JWK	
DESIGNS: MM	APPROVED BY: JWK	DATE: JWK	
DRAWN: JWK	DATE: JWK	DATE: JWK	TITLE: DM3422 Synthesized VHF Telemetry Module
FINISH:	RELEASE DATE:		DWG. NO.: D- 025-3422-050
			SCALE: N/A SHEET: 1 OF 1