

**Engineering Exhibit in Support of
Certification
FCC Form 731**

for the

Mobile Data Platform Transceiver (MDP)

With the

DATARADIO Gemini Modem

Trade Name: GEMINI/PD

December 4, 1998

AFFIDAVIT

The technical data included in this report has been accumulated through tests that were performed by me or by engineers under my direction. To the best of my knowledge, all of the data is true and correct.

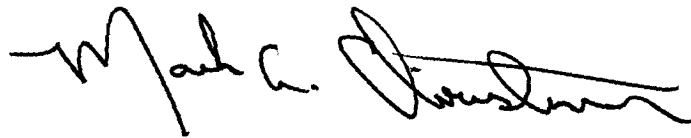
A handwritten signature in black ink, appearing to read "Mark C. Christensen". The signature is fluid and cursive, with a long horizontal stroke at the end.

Mark Christensen
Director of Engineering, Johnson Data Telemetry

Johnson Data Telemetry Corporation
Waseca, Minnesota

ENGINEERING STATEMENT OF CHRIS LUDEWIG

The application consisting of the attached engineering exhibit and associated FCC form 731, has been prepared in support of a request for Type Acceptance for the Johnson Data Telemetry (JDT) Mobile Data Platform (MDP), 403-512 MHz Transceiver with the Data Radio Gemini Modem. The MDP will be bought from JDT with the part# 242-60FC-MRB (see page 6 for part# description). Along with the modem a GPS receiver option is also available. The MDP Transceiver mated with the Gemini Modem and GPS receiver will be identified by the Data Radio part number 860-03322-xyz and marketed under the Model name GEMINI/PD. The Transceiver/Modem/GPS will be identified by the FCC number EOTGPDA. The transceiver operates pursuant to Part(s) 90 of the Rules and Regulations. The MDP Transceiver is available as a high power unit (10-50 Watts variable) or as a low power unit (2-13 Watts Variable).

EXISTING CONDITIONS

The units utilized for these type acceptance measurements were obtained from the pilot-production. The transceiver is designed to operate on frequencies ranging from 403.000 MHz to 512.000 MHz. The frequency tolerance of the transceiver is .00015% or 1.5 parts per million. The frequency stability of the transceiver is controlled by a temperature compensated crystal oscillator (TCXO) operating at 17.5 MHz.

PROPOSED CONDITIONS

It is proposed to Type Accept the GEMINI/PD, 403-512 MHz Transceiver/Modem/GPS for operation in the band of frequencies previously outlined. The applicant anticipates marketing the device for use in wireless transmission of data.

PERFORMANCE MEASUREMENTS

All Type Acceptance measurements were conducted in accordance with the Rules and Regulations Section 2.1041 of Pike & Fischer Inc., CD ROM revision 9/28/98. Equipment performance measurements were made in the engineering laboratory and on the FCC certified Open Area Test Site at the Transcrypt International / E.F. Johnson Radio Products located at 299 Johnson Avenue in Waseca, Minnesota. All measurements were made and recorded by myself or under my direction. The performance measurements were made between Sep 15, 1998 and Dec 1, 1998.

CONCLUSION

Given the results of the measurements contained herein, the applicant requests that Type Acceptance be granted for the 860-03322-xyz, 403-512 MHz Transceiver/Modem/GPS as tested for data communications.

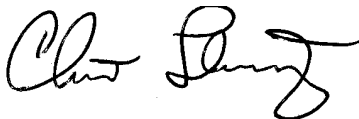

12/4/98

Chris Ludewig
Engineering Section Manager, Johnson Data Telemetry

Johnson Data Telemetry, Inc.
Waseca, Minnesota

TABLE OF CONTENTS

Title	1
Affidavit	2
Qualifications of Engineering Personnel	5
General Information	6
Transceiver Theory of Operation	7
Synthesizer Block Diagram	17
Transceiver Block Diagram	18
Modem Theory of Operation.....	19
Modem Block Diagram	22
Transistor, Diode, and IC Functions	23
Transmitter Tune Up Procedure	27
Instruction Manual	28
Test 1: Transmitter Rated Output Power.....	29
Test 2: Transmitter Occupied Bandwidth.....	30
Emission Designator Determination.....	30
Graph Mask D 8K60F1D 2 Watts 100 kHz Span.....	36
Graph Mask D 8K60F1D 13 Watts 100 kHz Span.....	37
Graph Mask D 8K60F1D 10 Watts 100 kHz Span.....	38
Graph Mask D 8K60F1D 50 Watts 100 kHz Span.....	39
Graph Mask B 15K3F1D 2 Watts 200 kHz Span.....	42
Graph Mask B 15K3F1D 13 Watts 200 kHz Span.....	43
Graph Mask B 15K3F1D 10 Watts 200 kHz Span.....	44
Graph Mask B 15K3F1D 50 Watts 200 kHz Span.....	45
Graph Mask B 15K0F1D 2 Watts 200 kHz Span.....	48
Graph Mask B 15K0F1D 13 Watts 200 kHz Span.....	49
Graph Mask B 15K0F1D 10 Watts 200 kHz Span.....	50
Graph Mask B 15K0F1D 50 Watts 200 kHz Span.....	51
Test 3: Transmitter Spurious and Harmonic Output	52
Test 4: Field Strength of Spurious Radiation	58
Test 5: Frequency Stability with Variation in Ambient Temperature	63
Test 6: Frequency Stability with Variation in Supply Voltage	66
Test 7: Transient Frequency Behavior	67
FCC Label	75
Photographs	76

QUALIFICATIONS OF ENGINEERING PERSONNEL

NAME: **Chris Ludewig**
TITLE: Engineering Section Manager
TECHNICAL EDUCATION: Bachelor of Science in Electrical and Electronic Engineering
(1984) From North Dakota State University
TECHNICAL EXPERIENCE: 14 years experience in design of portable and mobile radio equipment

NAME: **Mike Dickinson**
TITLE: Electrical Engineer III
TECHNICAL EDUCATION: Bachelor of Science in Electrical Engineering
(1994) from University of Illinois
TECHNICAL EXPERIENCE: 12 years experience in radio frequency measurements
4 years experience in radio frequency design

NAME: **Constantin Pintilei**
TITLE: R&D Test Engineer
TECHNICAL EDUCATION: Bachelor of Science Degree in Radiotechnique Electronic Engineering
(1993) Technical University of Iasi, Romania.
TECHNICAL EXPERIENCE: 5 Years experience in radio frequency measurements.

NAME: **Allen Frederick**
TITLE: Certified Technologist
TECHNICAL EDUCATION: Bachelor of Science Degree in Electronic Engineering Technology
(1998) from Mankato State University.
TECHNICAL EXPERIENCE: 2 years experience in analog and radio frequency communications.

GENERAL INFORMATION

RULE PART NUMBER: 2.1033 c(1)(2)(4)(5)(6)(7)

The following report has been generated for FCC Type Acceptance of the Data Radio part number 860-03322-xyz, 403-512 MHz Transceiver/Modem/GPS. Unless otherwise noted, all of the measurements were conducted following the procedures set forth in the TIA/EIA-603 standards.

MODEL NUMBER: GEMINI/PD
 PART NUMBER: 860-03322-xyz
 MANUFACTURER: Johnson Data Telemetry, Waseca, MN 56093 (MDP Transceiver)
 DATARADIO Inc., Town of Mount Royal, Quebec, Canada, H4P 1H7
 (Gemini- final assembly)
 FCC ID NUMBER: EOTGPDA
 FCC RULES AND REGS: FCC Part (s) 90
 FREQUENCY RANGE: 403.000 MHz - 512.000 MHz (406-406.1 MHz software blocked)
 SERIAL NUMBER (S): 450.000 MHz – FCC#1
 TYPE OF EMISSION: 12.5KHz BW (9600bps) **8K60F1D**
 25KHz BW (16.0Kbps) **15K3F1D**
 25KHz BW (19.2Kbps) **15K0F1D**
 MAXIMUM POWER RATING: 50.00 Watts (10-50 W variable)
 13.00 Watts (2-13 W variable)
 NUMBER OF CHANNELS: 16 Channel Modem
 INPUT IMPEDANCE: 50 ohms, Nominal
 VOLTAGE REQUIREMENTS: 13.6 VDC, Nominal
 EQUIPMENT IDENTIFICATION:

<u>TRADE NAME</u>	<u>DESCRIPTION</u>	<u>JDT PART NUMBER</u>
MDP6000 Gemini	403-512 MHz Transceiver Modem	242-60FC-MRB 050-03322-00x

JDT Part Number System for MDP:

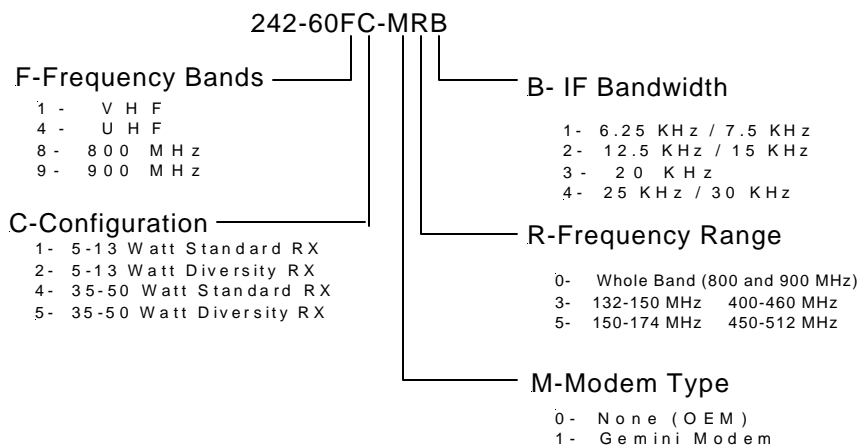

DESCRIPTION OF CIRCUITRY

RULE PART NUMBER: 2.1033 (c)(10)

MOBILE DATA PRODUCT

POWER AMPLIFIER (PA) CIRCUIT BOARD

CONNECTIONS

Power and ignition sense are supplied to the radio through J650. Since the power is connected directly to the vehicle battery, the ignition sense line tells the radio when the vehicle ignition is on. The PA board connects to the RF board via J600, a 10-pin socket. This connector supplies power to the RF board through F600 and provides control over the PA board. CR600, a transorb prevents negative voltages and extremely high positive voltages from damaging the radio by conducting and blowing the 12A in-line fuse.

The main antenna is connected to the PA board through J630, a mini-UHF connector. The transmitter output and main receiver input are provided through this 50 Ω connector. The main receiver signal is passed to the RF board through P200, a 50 Ω through-chassis connector. The transmit drive input comes from the RF board through P500, another 50 Ω through-chassis connector.

PA TEMPERATURE SENSE

One control signal provided to the RF board microprocessor is temperature sense. A thermistor (RT680 for 10W models, or RT690 for 40W models) is placed next to the final amplifier on the PA board and its resistance changes with the final amplifier temperature. The thermistor is biased by R405 on the RF board providing a voltage that varies linearly with temperature from 15°C to 125°C, the normal temperature range of the PA during use. If the final amplifier temperature exceeds a preset threshold, the microprocessor will fold back the power to prevent thermal destruction of the final.

PA CURRENT SENSE

Current to the final amplifier passes through R618 creating a proportional voltage across the resistor. U600B, CR614, CR616, R614, R615, R616, and R617 form a differential amplifier that amplifies the voltage across R618 and provide this voltage to the RF board microprocessor. When the final amplifier current exceeds a preset threshold due to high VSWR, the microprocessor will fold back the power to prevent thermal destruction of the final.

PA FORWARD POWER SENSE

The final amplifier output passes through a directional coupler that samples some of the transmit power and rectifies it through CR620 with C674 providing filtering of the RF content. Resistors R636 and R637 drop the voltage down to a suitable level for the microprocessor. The power sense voltage is proportional to the square root of the output power.

PRE-TRANSMIT ENABLE

The pre-transmit enable signal from the RF board prepares the PA board for transmit. The pre-driver, Q670, and driver, Q680, are biased on, and the antenna switch is configured for transmit by turning on CR640 and CR650.

TRANSMIT ENABLE

The transmit enable signal pulls the power control amplifier U600A out of saturation and allows the PA power to reach the programmed output level. When transmit enable is removed, U600A goes into saturation again causing the output power to drop to zero.

POWER CONTROL AND DRIVE BUFFER

The power set voltage from the RF board is applied to the non-inverting input of U600A. The PA forward power sense voltage is fed into the inverting input of U600A through CR605, R601 and R603. The output of U600A is fed into a high current amplifier consisting of Q640, Q650, R606, R607, and R608. This amplifier has a voltage gain of approximately two. The output of the high current amplifier provides bias and collector current for Q665, the drive buffer. When the power set voltage is greater than the forward power voltage, U660A turns the high current amplifier on harder increasing the bias to Q665, and providing more drive level. When the forward power voltage is greater than the power set voltage, U660A cuts the high current amplifier level down decreasing the bias to Q665, and reducing drive level.

The input to Q665 is from the PA buffer on the RF board through an attenuator formed by R619, R620, and R621. C623 and C624 provide the input match, with feedback from C625 and R624 for stability. The output of Q665 goes to the pre-driver Q670 with C626, C629, and C630 providing the interstage match.

3-WATT PRE-DRIVER

Transistor Q670 is a 3-Watt vertical MOSFET that provides pre-drive level for the 40W model and drive level for the 10W model. The output of this stage goes to Q680 with C639, C640, C641, C642, L602, and C643 providing the interstage match.

15-WATT DRIVER / FINAL (10W Model)

Transistor Q680 is a 15-Watt vertical MOSFET that provides drive level for the 40W model and is the final amplifier for the 10W model. The output of this stage goes to Q680 in the 40W model or is matched to 50 Ω in the 10W model. The interstage match consists of C651, C652, C653, L604, C656, C657, and C658. The 10W final match consists of C651, C652, C653, L604, C656, MP690, L608, C666, and C667.

50-WATT FINAL (40W Model Only)

Transistor Q690 is a 50-Watt bipolar transistor that is the final amplifier for the 40W model. The output of this stage is matched to 50 Ω using C664, C665, C666, L608, C667, and C668.

ANTENNA SWITCH

In receive, CR640 and CR650 are biased off and the main receive signal passes from J630, through the low pass filter, forward power detector, L610, C672, and C671 to P200, the RF board main receive input. In transmit, CR640 and CR650 are biased on, shorting the transmit path to the forward power detector and the receive path to ground. When the receive path is grounded, a high impedance is provided from a discrete quarter-wave section formed by C669, L610, and C670 to the transmit path providing rejection between the transmitter and the receiver.

LOW PASS FILTER

To reduce the harmonic content of the final amplifier, the transmit signal passes through a 7-pole low pass filter to the antenna. The low pass filter consists of C678, L612, C679, L614, C680, L616, and C681. R640 bleeds static charge from the antenna to protect the active devices in the power amplifier.

RADIO FREQUENCY (RF) CIRCUIT BOARD

CONNECTIONS

The RF board connects to the PA board via P600, a 10-pin header. This connector supplies power to the RF board and provides control over the PA board. The user or modem interface is provided by J400, a 2x12-pin socket. This connector supplies power to the modem or user interface through F401 and provides control over the RF deck.

A secondary interface is provided by J450, a 12-pin male socket, for programming the internal flash or servicing the RF deck while the modem is connected.

The main receiver input comes from the PA board through J200, a 50 Ω through-chassis connector. The transmitter driver output goes to the PA board through J500, another 50 Ω through-chassis connector. The diversity receiver input comes from J300, a panel mount mini-UHF connector that is connected through a length of coax to the RF board.

MICROCONTROLLER

The microcontroller is comprised of microprocessor U420, SCI (Serial Communications Interface) switch Q410 and U410, SPI (Serial Peripheral Interface) switch U430, and PWM (Pulse Width Modulation) filters U450 and U460. Y420 sets the microprocessor reference clock to 4.9152 MHz; the internal bus clock is phase-locked to 7.3728 MHz. The microcontroller has eight 8-bit ADC (Analog to Digital Converter) channels for sensing radio conditions, and five 8-bit PWM outputs with a period of 27.13 μ s. One PWM output is used to generate and adjust the internal negative supply for the VCO (Voltage Controlled Oscillator). The other four outputs are amplified and filtered to remove the PWM harmonics. These outputs are then used as 8-bit DACs (Digital to Analog Converters) with an output filter delay of 1ms.

The microcontroller loads the synthesizer, adjusts the Front-end receive filters to track across the RF band according to frequency and also controls the transmitter. The transmitter is calibrated at 4 points for RF output power, deviation and modulation flatness. The microcontroller interpolates for frequencies between the calibrated points to maintain equal power, deviation and modulation flatness across the entire RF band.

The SPI switch is used to change between internal onboard SPI operation and external off-board SPI operation. During internal operation the SPI_BUSY line is low, the BUSY_OUT line is high (if SPI protocol is enabled), and U430 connects the SPI lines to the internal serial devices, synthesizer U850, and digital pot U890. When the internal communications conclude, the SPI_BUSY line is brought high, and the BUSY_OUT line is brought low (if SPI protocol is enabled), and U430 connects the SPI lines to an external device (modem) through J400.

The microprocessor's internal Flash memory is programmed by applying a positive voltage to the AUX FLASH ENABLE (J450 pin3) or XCVR FLASH ENABLE (J400 pin4) and resetting the processor by either cycling power or sending a software reset command serially. The positive voltage turns on Q31 and Q30 applying approximately 10.1V to the microprocessor IRQ (Interrupt ReQuest) pin. Upon reset, all microprocessor ports are configured as inputs and the microprocessor enters Background Debug Mode (BDM). Transistor Q410 is turned off and U410 connects the 5V RS-232 lines to Port A, Pin 0, the BDM Port. Pre-Boot code is sent via the 5V RS-232 lines into RAM through the BDM Port. The Pre-Boot code configures the SCI port for 9600 baud, Port C Pin 5 is brought high turning on Q410 which switches U410 and connects the 5V RS-232 lines to the SCI port to accept the Boot Code. Flash programming resumes through the SCI port at 9600 baud. When programming is finished, the programming voltage must be removed from the AUX FLASH ENABLE (J450 pin3) and XCVR FLASH ENABLE (J400 pin4), and the microprocessor reset for normal operation to continue.

TEMPERATURE SENSE

Integrated circuit U440 provides a voltage to Port B Pin 0 that is proportional to the temperature in the RF cavity. By monitoring the temperature, the microprocessor can compensate for temperature variations in the radio.

+5V LOGIC REGULATOR AND RESET GENERATOR

The input voltage on pin 1 of P600 is regulated by U10 to provide +5V for the logic section. The reset for the microprocessor is provided by U20 on power-up. The shutdown (SD) pin is pulled low when RF_ENABLE is asserted from either the modem or AUX connectors. When the processor powers up, it pulls the SD pin low by asserting the RF_ENABLE_OVERRIDE on Port A Pin 2. When the RF_ENABLE lines are both brought low, the processor removes the RF_ENABLE_OVERRIDE signal and U10 removes power to the logic section. In case of a

higher than normal current situation, U10 will go into thermal foldback which will decrease the output voltage to stabilize the internal die temperature preventing destruction of the regulator.

+5.5V AND +9.6V REGULATORS AND +2.5V REFERENCE

When the microprocessor asserts the TRANSCEIVER_ENABLE line, Q20 and Q21 turn on providing power to the +5.5V and +9.6V regulators as well as generating a precision +2.5V reference. C20 and C21 serve two purposes: first, they filter the +2.5V reference, second, they form a capacitive voltage divider that allows the reference to reach +2.5V almost instantly. The +5.5V and +9.6V regulators are regulated off of the +2.5V reference; when U10 goes into thermal shutdown, both supplies as well as the reference voltage follow. Since the microprocessor is unable to control the radio under this condition, this mechanism provides a path to shutdown the RF section.

The +9.6V linear regulator consists of U40B, Q40, Q41 and associated components. This regulator powers the PWM filters, negative voltage generator, VCOs, transmit drivers, LNAs, LO amps, and IF amps. The microprocessor controls the voltage to the transmit drivers through Q94 and Q95. Voltages to the receiver LNAs, LO amps, and IF amps are controlled by Q90 and Q91 for the main receiver and Q92 and Q93 for the diversity receiver. The +5.5V linear regulator consists of U40A, Q50, Q51, Q52 and associated components. This regulator powers the TCXO, synthesizer IC, digital pot, IF ICs, bandwidth switch and data amplifiers.

NEGATIVE VOLTAGE GENERATOR

To minimize switching transients on the supply line, the negative voltage generator uses a constant current source consisting of Q70, Q71, Q72 and R74 in a current mirror configuration. The microprocessor generates the NEG_SWITCH signal as a PWM output that turns Q74 and Q73 off and on. When the Q74 is off, Q71 charges C73 through the lower half of CR70. At the same time, Q73 is off and Q72 charges C70 through both halves of CR70. When Q74 is on, the positive side of C73 is shorted to ground, Q73 is on which shorts the positive side of C70 to the negative side of C73. The negative side of C70 has voltage amplitude that is approximately double the charge voltage of a single capacitor. This voltage is then used to charge C71 and C72 through CR72. By varying the PWM duty cycle, the negative supply voltage can be adjusted.

The output of the negative supply is fed back to the microprocessor through CR78, R78, and R79 to Port B Pin 7. Zener diode CR78 protects the microprocessor from the negative voltage if R79 failed, and protects C72 from reverse voltage when power is removed from the negative supply. The feedback to microprocessor allows it to regulate the negative supply over voltage and temperature variations.

NEGATIVE VOLTAGE SWITCH

The negative voltage switch consists of R81 – R89, C81 – C88, and one-of-eight analog switch, U80. Switch U80 selects one of the taps from the resistive divider formed by R81 through R89. Capacitors C81 through C88 are used to filter each tap point. The purpose of the negative voltage switch is to permit fast switching of the negative voltage to the VCO for large frequency variations.

CAPACITOR MULTIPLIERS

The capacitor multiplier consists of CR805, R805, C805, and Q805 for the Main VCO, and CR139, R139, C139, and Q139 for the 2nd LO VCO. The transistor is configured as an emitter follower with the base voltage being provided by the RC filter. The diode is used to bridge the large resistor voltage on power-up to allow the circuit to turn on quickly.

MAIN VCO (A900)

The main VCO assembly is constructed on a separate PC board that is then placed on the RF Board. Transistor Q900 is the heart of the modified Colpitts oscillator. Capacitors C928 and C930 provide the feedback for oscillation. The tank is coupled to the base of Q900 through C924. The oscillator tank inductance is provided by

Z900, a dielectric resonator. CR904, CR906, CR908, and CR910 are varactor diodes that provide capacitive adjustment of the frequency over varying control voltages. The synthesizer control voltage is provided to the cathode of the diodes, and the negative voltage switch output is provided to the anodes. C918 and C908 couple the varactors to the tank. In transmit, CR912 switches in C910, C912, and C914 to move the VCO frequency down and restore VCO gain back to the same level as in receive. When a modulated signal is provided to CR900, the diode's capacitance varies inversely with the amplitude of the signal. This diode is coupled to the tank by C904 and C906 so that the tank frequency varies proportionally with the signal amplitude.

CASCADE AMPLIFIER (A900)

Transistors Q902 and Q904 form a common emitter cascade amplifier with shared bias to increase signal level and buffer the oscillator. This output is then used for prescaler feedback for the synthesizer. In addition, the output level is then increased by common emitter amplifier Q906 and provided as the main RF output.

VCO RX / TX Splitter

The output of the VCO passes through a two-way resistive splitter formed by R810, R811, R812, and R813 to the Receive LO Buffer Amp and the Transmit Driver.

MAIN VCO PIN SHIFT CIRCUITRY

Transistors Q821 and Q820 provide the voltage for the main VCO pin shift. The outputs of these transistors are inverted from each other so that the pin diodes on A900 are either forward biased when the 9.6 pre-transmit voltage is applied or reverse biased when it is removed.

2nd LO VCO

The second LO VCO is a modified Colpitts oscillator with Q140 as the oscillator transistor. Capacitors C143 and C147 provide the necessary feedback. Capacitor C141 couples the tank to the base of Q140. Inductor L140 provides the oscillator tank inductance. Varactor diode CR140 allows the oscillator frequency to vary proportionally with the control line voltage. Capacitor C146 couples the CR140 into the tank. Transistor Q141 buffers the oscillator output back to the synthesizer prescaler. Transistors Q270 and Q370 buffer the oscillator to the main and diversity receivers respectively.

TCXO

The reference for the synthesizer is provided by TCXO (Temperature Compensated Crystal Oscillator) Y890. This oscillator provides a stable 17.5 MHz output that is compensated to within ± 1.5 PPM over temperature.

FRACTIONAL-N SYNTHESIZER

To maintain stable VCO frequencies, the main and 2nd LO VCOs are phase locked to the standard provided by the TCXO. The TCXO signal enters the reference pin of synthesizer IC U850 where the frequency is divided down to 50 kHz through a programmable R divider. This signal is then provided to one input of both internal phase detectors. The other phase detector input comes from programmable N counters which use the main and 2nd LO VCOs as input. The phase detector generates a current that corresponds to the difference in frequency between the VCO reference and the TCXO reference. The output of the phase detectors pass through loop filters consisting of R840 – R842, and C840 – C843 for the main loop and R141, R143, C145, C146, C148, and C149 for the 2nd LO loop. The loop filters strip off the reference frequency and convert the input current to an output voltage to steer the VCOs on frequency.

The N dividers for the main loop are fractional so channel steps can be made at a fraction (1/8) of the 50kHz reference. This capability allows for narrow 6.25kHz channel steps while maintaining a faster lock time due to the

50kHz reference. Digital Potentiometer U890D adjusts the compensation current to minimize fractional spurious frequencies across the band.

LOCK DETECT

When the phase difference between the two inputs to the phase detector is less than one cycle, the lock detect output goes high to tell the microcontroller that the synthesizer is locked. The lock detect output only goes high when both the main and 2nd LO synthesizer loops are locked.

MODULATION BALANCE AND TX DATA GAIN

The TX data input is switched by U110B, an analog switch, to provide the necessary gain difference between the 12.5kHz and 25kHz versions of the radio. The data is amplified by U880A and the deviation is set by U890A. The signal is amplified further by U880B where the output is coupled to the TCXO modulation pin by R895. The TCXO modulation passes frequencies below the loop frequency of the main synthesizer. The output is also coupled through U890B to the VCO modulation input. The VCO modulation passes frequencies above the loop frequency. The VCO and TCXO inputs are balanced by U890B to provide a flat frequency response.

TRANSMIT DRIVER

The VCO output from R811 of the splitter passes through an attenuator formed by R560, R561, and R562 to Q550, a MMIC (Monolithic Microwave Integrated Circuit) amplifier. Q550 receives bias from R550, R551, and L550 when the 9.6V Pre-transmit voltage is applied. The output from Q550 is coupled through an attenuator formed by R528, R529, and R530 to transmit driver Q520. Q510, R517, R518, R525, and R526 provide bias to Q520. C520, L520, and C523 provide input matching to Q520, with output matching provided by L515, C515, and C516. The transmit driver 50 mW output then passes through to the PA board through J500.

RECEIVE 1st LO BUFFER AMP

The VCO output from R810 of the splitter passes through an attenuator formed by R117 (or C119), R118, and R119 and is coupled through C116 to the receive 1st LO buffer amplifier. The buffer amplifier consists of Q111 in a common emitter configuration with C114 and R115 providing feedback for stability. Q110, R110, R111, R112, R114, and R116 provide active bias for Q111. The input is matched by L111, C117 and C118, and the output is matched by L110, R113, and C115. The output of the 1st LO buffer passes through a resistive splitter formed by R180, R182, R184, and R186 to the 1st LO amplifiers for the main and diversity receivers.

QUARTER-WAVE TRANSMIT/RECEIVE SWITCH

The main receiver input passes through J100 from the PA board. Capacitor C201 provides input matching is needed. The receive signal passes through a quarter-wave microstrip line and is coupled through C204 to the main receiver preselector filter. In transmit, the 9.6PTX voltage biases pin diode CR202 into conduction shorting the end of the quarter-wave microstrip line through C202. The shorted line provides a high impedance to the PA board preventing the transmitter output from passing into the receiver.

MAIN RX 2-POLE AND 3-POLE PRESELECTORS

Receive input spurious rejection is provided by the 2 pole and 3 pole preselector filters. Both filters are varactor tuned to provide optimum spurious rejection and minimum loss across the band. A single tuning voltage is provided by U450A. Capacitors C216, C217, C238, C239, and C240 decouple the RF from the tuning voltage. Resistors R210, R212, R238, R239, and R240 couple the bias voltage to the varactors. Varactors CR211, CR210, CR232, and CR233 are grounded through the tank inductors and are coupled to their individual tanks by C218, C219, C241, and C242 respectively. To improve intermodulation performance, the first tank of the 3-pole filter has four varactors CR230, CR231, CR236, and CR237 in a parallel – series combination that nearly equals the capacitance of a single varactor. The combination reduces the current and voltage across each individual varactor.

Capacitors C214, C215, C235, C236, and C237 provide supplemental tank capacitance. Tank inductance is provided by L216, L218, L240, L242, and L244. Series inductors L212, L214, L234, L236, and L238 add a notch at the image frequency that tracks as the varactor bias is changed. The tanks are coupled by L210, L230, and L232.

Input matching is done through C210 and C211 on the 2 pole and C230 and C233 on the 3-pole filter. Output matching is likewise accomplished with C212 and C213 on the 2 pole and C232 and C234 on the 3-pole filter.

MAIN RX LOW NOISE AMPLIFIER

The low noise amplifier (LNA) consists of Q221 in a common emitter configuration with C225 and R225 providing feedback for stability and R230 and R231 providing emitter degeneration. Q220, R220, R221, R222, R224, and R226 provide active bias for Q221. Switching diode CR220 prevents large signals from damaging the LNA. The input is matched by L222, C228 and C229, and the output is matched by L220, R223, and C227. The output of the LNA passes through an attenuator formed by R233, R234 (or C226), and R235.

MAIN RX 1st LO AMPLIFIER

The VCO output from R180 of the splitter is coupled through C266 to the LO amplifier. The amplifier consists of Q261 in a common emitter configuration with C264 and R265 providing feedback for stability. Q260, R260, R261, R262, R264, and R266 provide active bias for Q261. The input is matched by L262, C267 and C268, and the output is matched by L260, R263, and C265. The output of the amplifier is 50mW.

MAIN RX 1st MIXER AND DISSIPATIVE FILTER

The first mixer is a passive double balanced device that converts the RF input to the 1st IF frequency of 55 MHz. C243 matches the LO input to the mixer. The IF output of the mixer passes through a dissipative filter that is designed to provide a 50 ohm termination to the mixer and 1st IF filter at all frequencies.

MAIN RX 1st IF FILTER

The 1st IF filter is a 55 MHz 4 pole crystal filter, Z250, that provides attenuation of the adjacent channel and close intermodulation frequencies. Capacitors C254 and C255 couple the 2-pole section together. The input is matched by C250, C253, C248, and L248. The output is matched by C249, C256, C252, and L250.

MAIN RX 1st IF AMPLIFIER

The 1st IF signal is amplified by Q250 in a common emitter configuration. Resistors R245, R248, and R249 bias the amplifier. C257 matches the input. C247 and R272 matched the output to the 2nd mixer in U260.

MAIN RX 2nd LO BUFFER

Buffer Q270 is set up in an emitter follower configuration that is biased by R275 and R140. C277 and L272 notch out any 450kHz signals from reaching the buffer. C282 couples the receive 2nd LO to the mixer in U260.

MAIN RX 2nd MIXER AND 2nd IF FILTER

The 2nd mixer is a Gilbert cell configuration located in U260. The mixer converts the 55 MHz 1st IF down to a 450 kHz 2nd IF. The 2nd IF is filtered by Z280 that is a 4-pole constant group delay ceramic filter.

MAIN RX 2nd IF AMPLIFIER AND 2nd IF FILTER

The filtered 2nd IF passes through an IF amplifier in U260. This amplifier generates part of the RSSI current internal to U260. The 2nd IF is filtered again by Z270, another 4-pole constant group delay ceramic filter.

MAIN RX LIMITER AND QUADRATURE DETECTOR

The filtered 2nd IF passes through an IF limiter in U260. The limiter removes variations in signal amplitude and generates the remaining current for RSSI output. The output of the limiter connects directly into one input of the quadrature detector. The other input of the quadrature detector comes from the limiter through C273 and L270, a 450 kHz tank. The capacitively coupled input is shifted 90° in phase from the direct input. When no modulation is present, the quadrature detector has no output. When the IF frequency changes due to modulation, the phase shift changes also causing the baseband signal to be recovered from the quadrature detector.

MAIN RX RSSI BUFFER

The 2nd IF amplifier and limiter generate a current that is proportional to input signal level. The current is passed through a temperature compensated resistor internal to U260 converting the current in to a voltage that is passed to a buffer operational amplifier in U260. Resistors R285, R286, R287, and R288 provide a gain and compensation network for the RSSI voltage. Frequency and temperature variations in RSSI voltage are compensated by the microprocessor and the resulting compensated RSSI is passed to the modem interface.

MAIN RX DATA BUFFER AND GAIN SWITCH

The recovered baseband signal from the quadrature detector is amplified by an internal operational amplifier in U260 using R289 and R290 as gain fixing resistors. The signal then passes through U110A that switches the signal either through R292 for unity gain or R293 for twice the gain depending upon the programming of the gain switch. U120A buffers or amplifies the signal stripping off the 450 kHz components. The signal is then passed to the modem interface and the auxiliary connector.

DIVERSITY RX LOW PASS FILTER

The diversity receiver input passes from J300 through a 7-pole low pass filter (LPF), to the preselector input. The LPF improves the above band rejection and makes the main and diversity receivers as similar as possible. The low pass filter consists of C303, L302, C304, L303, C305, L304, and C306. R302 bleeds static charge from the antenna to protect the active devices in the diversity receiver.

DIVERSITY RX 2-POLE AND 3-POLE PRESELECTORS

Receive input spurious rejection is provided by the 2 pole and 3 pole preselector filters. Both filters are varactor tuned to provide optimum spurious rejection and minimum loss across the band. A single tuning voltage is provided by U460A. Capacitors C316, C317, C338, C339, and C340 decouple the RF from the tuning voltage. Resistors R310, R312, R338, R339, and R340 couple the bias voltage to the varactors. Varactors CR311, CR310, CR332, and CR333 are grounded through the tank inductors and are coupled to their individual tanks by C318, C319, C341, and C342 respectively. To improve intermodulation performance, the first tank of the 3-pole filter has four varactors CR330, CR331, CR336, and CR337 in a parallel – series combination that nearly equals the capacitance of a single varactor. The combination reduces the current and voltage across each individual varactor.

Capacitors C314, C315, C335, C336, and C337 provide supplemental tank capacitance. Tank inductance is provided by L316, L318, L340, L342, and L344. Series inductors L312, L314, L334, L336, and L338 add a notch at the image frequency that tracks as the varactor bias is changed. The tanks are coupled by L310, L330, and L332.

Input matching is done through C310 and C311 on the 2 pole and C330 and C333 on the 3-pole filter. Output matching is likewise accomplished with C312 and C313 on the 2 pole and C332 and C334 on the 3-pole filter.

DIVERSITY RX LOW NOISE AMPLIFIER

The low noise amplifier (LNA) consists of Q321 in a common emitter configuration with C325 and R325 providing feedback for stability and R330 and R331 providing emitter degeneration. Q320, R320, R321, R322, R324, and R326 provide active bias for Q321. Switching diode CR320 prevents large signals from damaging the LNA. The input is matched by L322, C328 and C329, and the output is matched by L320, R323, and C327. The output of the LNA passes through an attenuator formed by R333, R334 (or C326), and R335.

DIVERSITY RX 1st LO AMPLIFIER

The VCO output from R180 of the splitter is coupled through C366 to the LO amplifier. The amplifier consists of Q361 in a common emitter configuration with C364 and R365 providing feedback for stability. Q360, R360, R361, R362, R364, and R366 provide active bias for Q361. The input is matched by L362, C367 and C368, and the output is matched by L360, R363, and C365. The output of the amplifier is 50mW.

DIVERSITY RX 1st MIXER AND DISSIPATIVE FILTER

The first mixer is a passive double balanced device that converts the RF input to the 1st IF frequency of 55 MHz. C343 matches the LO input to the mixer. The IF output of the mixer passes through a dissipative filter that is designed to provide a 50 ohm termination to the mixer and 1st IF filter at all frequencies.

DIVERSITY RX 1st IF FILTER

The 1st IF filter is a 55 MHz 4 pole crystal filter, Z350, that provides attenuation of the adjacent channel and close intermodulation frequencies. Capacitors C354 and C355 couple the 2-pole section together. The input is matched by C350, C353, C348, and L348. The output is matched by C349, C356, C352, and L350.

DIVERSITY RX 1st IF AMPLIFIER

The 1st IF signal is amplified by Q350 in a common emitter configuration. Resistors R345, R348, and R349 bias the amplifier. C357 matches the input. C347 and R372 matched the output to the 2nd mixer in U360.

DIVERSITY RX 2nd LO BUFFER

Buffer Q370 is set up in an emitter follower configuration that is biased by R375 and R140. C377 and L372 notch out any 450kHz signals from reaching the buffer. C382 couples the receive 2nd LO to the mixer in U360.

DIVERSITY RX 2nd MIXER AND 2nd IF FILTER

The 2nd mixer is a Gilbert cell configuration located in U360. The mixer converts the 55 MHz 1st IF down to a 450 kHz 2nd IF. The 2nd IF is filtered by Z380 that is a 4-pole constant group delay ceramic filter.

DIVERSITY RX 2nd IF AMPLIFIER AND 2nd IF FILTER

The filtered 2nd IF passes through an IF amplifier in U360. This amplifier generates part of the RSSI current internal to U360. The 2nd IF is filtered again by Z370, another 4-pole constant group delay ceramic filter.

DIVERSITY RX LIMITER AND QUADRATURE DETECTOR

The filtered 2nd IF passes through an IF limiter in U360. The limiter removes variations in signal amplitude and generates the remaining current for RSSI output. The output of the limiter connects directly into one input of the quadrature detector. The other input of the quadrature detector comes from the limiter through C373 and L370, a 450 kHz tank. The capacitively coupled input is shifted 90° in phase from the direct input. When no modulation is present, the quadrature detector has no output. When the IF frequency changes due to modulation, the phase shift changes also causing the baseband signal to be recovered from the quadrature detector.

DIVERSITY RX RSSI BUFFER

The 2nd IF amplifier and limiter generate a current that is proportional to input signal level. The current is passed through a temperature compensated resistor internal to U360 converting the current in to a voltage that is passed to a buffer operational amplifier in U360. Resistors R385, R386, R387, and R388 provide a gain and compensation network for the RSSI voltage. Frequency and temperature variations in RSSI voltage are compensated by the microprocessor and the resulting compensated RSSI is passed to the modem interface.

DIVERSITY RX DATA BUFFER AND GAIN SWITCH

The recovered baseband signal from the quadrature detector is amplified by an internal operational amplifier in U360 using R389 and R390 as gain fixing resistors. The signal then passes through U110C that switches the signal either through R392 for unity gain or R393 for twice the gain depending upon the programming of the gain switch. U120B buffers or amplifies the signal stripping off the 450 kHz components. The signal is then passed to the modem interface and the auxiliary connector.

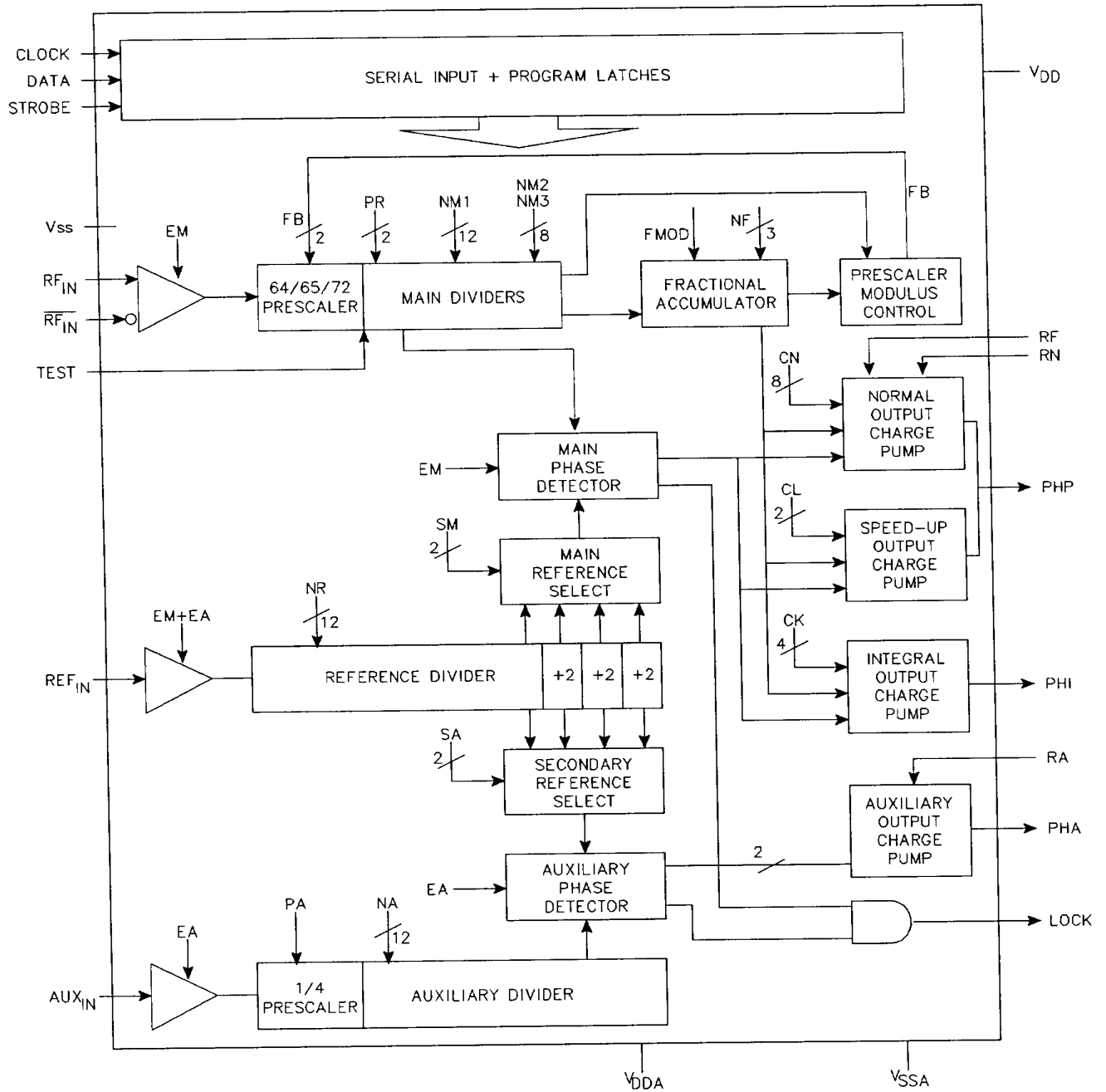

Figure 1: DL-3412 SYNTHESIZER INTEGRATED CIRCUIT (U811)

Figure 2: MDP TRANSCEIVER BLOCK DIAGRAM

DESCRIPTION OF CIRCUITRY

RULE PART NUMBER: 2.1033 (c)(10)

Introduction

The Gemini/PD is a mobile radio-modem housed in an aluminum cabinet. It comprises a transceiver with a second diversity receiver, a variable 2-50 Watt power amplifier and a Gemini Control Unit (GCU). The modem used on the GCU is Digital Signal Processor (DSP) driven data modulator and a diversity capable demodulator for operation at up to 9600 b/s in half channels and up to 19.2 Kb/s in full channel radios. Gemini/PD is equipped with an integrated OEM GPS receiver.

The GCU (p/n 050-03322-00x) is described below:

The main functions of the board includes:

- loading the radio frequencies,
- providing the baseband modulating signal for the transmitter,
- demodulating the receive audio signals,
- interfacing the OEM GPS receiver (to get mobile position)

The GCU is divided into 4 sub-sections:

- a) CPU block
- b) Modem block
- c) Power Supply Unit (PSU)
- d) OEM GPS receiver board (ASHTECH G8™)

A circuit block diagram of the GCU is located at the end of this section (see Figure 3).

CPU circuit description

a) General:

The CPU block is designed around three 84C015 Intelligent Peripheral Controller (IPCs) designated as U6, U16 and U21. This implementation provides central processing, watchdog, 128-bit CTC channels, 48-bits of I/Os, and a total of 6 serial ports with independent baud rates. These serial ports are configured as: 3 external user ports, 1 sync network port, 1 async radio port, and 1 internal async GPS receiver port.

The CPU block interfaces to:

- The DSPmodem
- RS232 ports (3)
- Transceiver
- GPS receiver port

b) Circuit functions:

The CPU block controls the operation of the whole radio-modem. It uses a “master” IPC processor (U6) and two IPC (U16 and U21) used as “slaves” for interfacing functions.

The CPU clock generator uses a 19.6608 MHz crystal oscillator that provides the master clock rate of 9.8304 MHz for all IPC processors. The timing signal provided for all CTC timer/counters is equal to half the master clock frequency.

The master IPC generates the baud rates for RS 232 ports 2 & 3 using two of its timers. The third timer provides the SYNC signal to the 5V power supply DC-DC converter (U7). Finally, its fourth timer provides the clocking for U21. The master processor also controls the SRAM (U2) and Flash memory (U1).

The second IPC (U21), interfaces to the transceiver and controls RS232 port 1 using one of its internal timers to generate baud rates. The programming and tuning operations for the 16 radio channels can be performed using this async port and only by the manufacturer's loader software.

The third IPC (U16), interfaces to the DSP modem (U13) through a serial buffer (U9) for network data and to the OEM GPS receiver. The serial interface to the DSP modem operates at the nominal network speed (up to 19200 bps). A parallel connection through a parallel buffer (U8) supports future enhancements. The IPC (U16) uses one of its timers to clock the OEM GPS interface, and its three remaining timers are cascaded to provide an internal 24-bit timer.

c) Watchdog circuit:

The watchdog circuit is based on U5 (ADM705AR). This circuit provides a 200msec reset pulse on power-on and manual reset. Its internal watchdog timer has a 1.6 second duration. In addition, it oversees two other reset sources: the master processor's watchdog timer and the DSP watchdog pulse.

DSP modem circuit description

a) General:

The DSP modem is based on a Motorola DSP56303 (U13) operating at an oscillator frequency of 12.228 MHz. The main modem function is to convert the digital data into analog filtered waveforms used to modulate the transceiver with DGFSK (Differential Gaussian Frequency Shift Keying).

The DSP modem interfaces with the master IPC using the serial ports buffered by U9.

The transceiver and the DSP modem interface uses five analog signals:

- XCVR_TXMOD (TXA, outgoing audio signal)
- XCVR_RX1 (RXA_1 incoming audio signal)
- XCVR_RX2 (RXA_2 incoming audio signal)
- CH0 (main receiver' RSSI_1)
- CH1 (diversity receiver' RSSI_2)

The transceiver and the diversity receiver audio incoming channels are processed by U11 (PCM3002 CODEC) using a sampling frequency of 48 KHz. It provides dual filtered audio bi-directional channels, with separate pairs of A/D-D/A converters

The DSP modem circuit processes both Receivers' RSSI signals from the transceiver using U12 (AD7811), a 10-bit serial A/D converter.

b) Operations:

PTT is under master IPC control. The channel selection and the synthesizer frequency are under control of IPC U21.

When transmitting, transmit data from the an RS-232 port are received by RS-232 interface circuits (U15, U17 or U22), TTL level shifted and fed to U6 or U21 to be redirected to U16. Then the digital data are clocked-in from the U16 by the U13 via the sync serial port. The DSP modem will encode the data stream and the resulting baseband DGFSK

digital signal is then converted by the CODEC into an analog filtered signal suitable for the RF modulator. The DSP controls deviation level and fine frequency adjust (i.e. warp).

When receiving, both RSSI signals are sampled and A/D converted by U12, then fed to the DSP modem. Both transceiver and secondary receivers' audio signals are read from the CODEC by the DSP. This is transformed to a digital data stream clocked-out via the DSP sync serial port to U16 at the network speed. Further, the received U16 data are redirected to an output port by U6 and RS-232 level shifted by U15, U17 or U22.

Power Supply Unit

The power supply circuit uses U7 (LT1375) DC-DC switching regulator to provide the 5V to the system (including power to the GPS receiver). The linear regulator U14 (LT1129) provides the 3.3V. The GCU is fuse protected from the transceiver DC power input (raw_bat).

G8™ OEM GPS receiver board

The G8™ OEM Global Positioning System (GPS) receiver, by Ashtech, is designed specifically for use as an OEM board. The G8™ supports two TTL serial communication ports; one of which is used to interface to the GCU. The receiver outputs up to one GPS based position information per second serially at 4800 bps.

The G8™ processes signals from the GPS satellite constellation to provide real-time position, velocity, and time measurements. The G8™ receives satellite signals via an external active L-band antenna. The DGPS corrections if used, will be input into to the GPS receiver via the GCU.

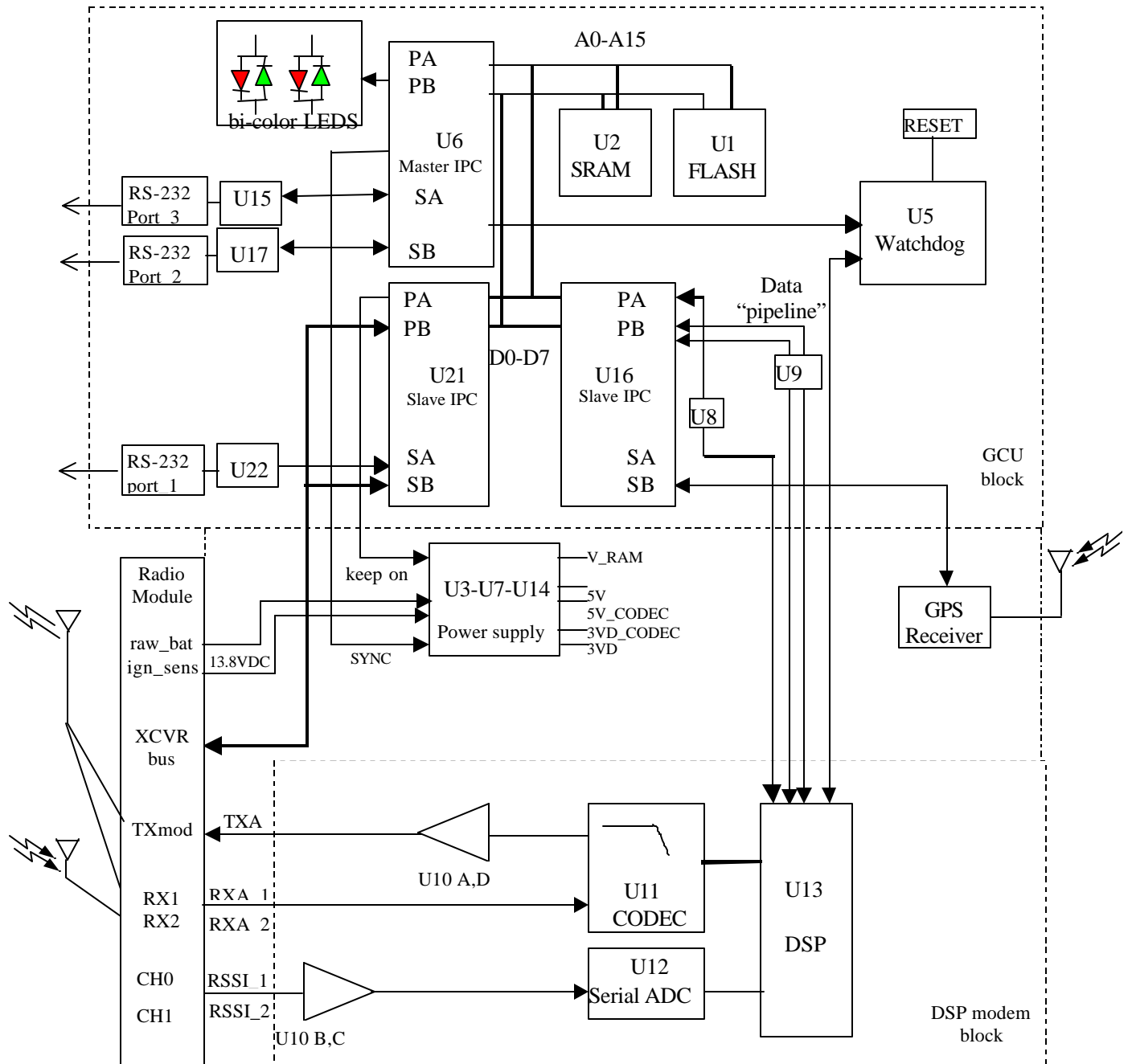

Figure 3: GEMINI(GCU) MODEM BLOCK DIAGRAM

TRANSISTOR, DIODE, AND IC FUNCTIONS

RULE PART NUMBER: 2.1033 c (10)

MDP TRANSCEIVER

<u>Manufacturer Part#</u>	<u>JDT Part#</u>	<u>References</u>	<u>Function</u>
BB535	623-5005-022	CR139	Diode for Cap Multiplier
MMBV609	623-5005-023	CR140	2nd LO Tuning Varactor
MMBV3401	623-1504-001	CR202	Transmit to Receive Switch
BB535	623-5005-022	CR210	RX Front End 2 Pole Preselector Main RX
BB535	623-5005-022	CR211	RX Front End 2 Pole Preselector Main RX
MMBD6050	623-1504-002	CR220	LNA Overload Protection Diode Main RX
BB535	623-5005-022	CR230	RX Front End 3 Pole Preselector Main RX
BB535	623-5005-022	CR231	RX Front End 3 Pole Preselector Main RX
BB535	623-5005-022	CR232	RX Front End 3 Pole Preselector Main RX
BB535	623-5005-022	CR233	RX Front End 3 Pole Preselector Main RX
BB535	623-5005-022	CR236	RX Front End 3 Pole Preselector Main RX
BB535	623-5005-022	CR237	RX Front End 3 Pole Preselector Main RX
BZX84C	623-2016-519	CR30	Flash Voltage Switch
BB535	623-5005-022	CR310	RX Front End 2 Pole Preselector Diversity RX
BB535	623-5005-022	CR311	RX Front End 2 Pole Preselector Diversity RX
MMBD6050	623-1504-002	CR320	LNA Overload Protection Diode Diversity RX
BB535	623-5005-022	CR330	RX Front End 3 Pole Preselector Diversity RX
BB535	623-5005-022	CR331	RX Front End 3 Pole Preselector Diversity RX
BB535	623-5005-022	CR332	RX Front End 3 Pole Preselector Diversity RX
BB535	623-5005-022	CR333	RX Front End 3 Pole Preselector Diversity RX
BB535	623-5005-022	CR336	RX Front End 3 Pole Preselector Diversity RX
BB535	623-5005-022	CR337	RX Front End 3 Pole Preselector Diversity RX
BZX84C	623-2016-519	CR453	Protection Diode
BZX84C	623-2016-519	CR456	Protection Diode
BZX84C	623-2016-519	CR457	Protection Diode
BZX84C	623-2016-519	CR485	Protection Diode
BZX84C	623-2016-519	CR486	Protection Diode
BZX84C	623-2016-519	CR488	Protection Diode
MR2535L	623-2906-001	CR600	Voltage Suppressor
BB535	623-5005-022	CR605	Power Control Diode
BB535	623-5005-022	CR610	TX Enable Diode
BB535	623-5005-022	CR614	Drop V Below Op-Amp Rail V for Current Sense
BB535	623-5005-022	CR616	Drop V Below Op-Amp Rail V for Current Sense
MMBD701LT1	623-1504-016	CR620	Antenna Switch
BZX84C	623-2016-519	CR630	Power Control Limit
MA47059	623-1504-032	CR640	Antenna Switch
MA47059	623-1504-032	CR650	Antenna Switch
MBAV99	623-1504-023	CR70	Negative Voltage Regulator
MBAV99	623-1504-023	CR72	Negative Voltage Regulator
BZX84C	623-2016-519	CR78	Protection Diode
BB535	623-5005-022	CR805	Diode for Cap Multiplier
BB535	623-5005-022	CR900	Modulation Varactor
BB535	623-5005-022	CR904	VCO Varactor, Freq Tuning
BB535	623-5005-022	CR906	VCO Varactor, Freq Tuning

TRANSISTOR, DIODE, AND IC FUNCTIONS (Continued)

RULE PART NUMBER: 2.1033 c (10)

<u>Manufacturer Part#</u>	<u>JDT Part#</u>	<u>References</u>	<u>Function</u>
BB535	623-5005-022	CR908	VCO Varactor, Freq Tuning
BB535	623-5005-022	CR910	VCO Varactor, Freq Tuning
4035	623-1504-035	CR912	VCO TX Pin Shift
MUN5213T1	676-0013-046	Q10	RF Enable Override
MSD1819A	676-0013-701	Q11	Modem RF Enable
MSB1218A	676-0013-700	Q110	RX 1st LO Buffer Amplifier Active Bias
MRF9411	676-0003-618	Q111	RX 1st LO Buffer Amplifier
MSD1819A	676-0013-701	Q12	Auxiliary RF Enable
MSD1819A	676-0013-701	Q13	Auxiliary RF Enable
MSD1819A	676-0013-701	Q139	Cap Multiplier on 2nd LO VCO Buffer
MMBT918	676-0003-634	Q140	RX 2nd LO Oscillator
MMBT918	676-0003-634	Q141	2nd LO Buffer Amplifier
MUN5114T1	676-0013-032	Q20	Transceiver Enable
MUN5213T1	676-0013-046	Q21	Transceiver Enable
MSB1218A	676-0013-700	Q220	RX LNA Active Bias Main RX
MRF9411	676-0003-618	Q221	RX LNA Main RX
MMBT918	676-0003-634	Q250	IF Amplifier Main RX
MSB1218A	676-0013-700	Q260	1st LO Amplifier Main RX
MRF9411	676-0003-618	Q261	1st LO Amplifier Main RX
MMBT918	676-0003-634	Q270	2nd LO Supply Switch
MUN5114T1	676-0013-032	Q30	Flash Voltage Switch
MSD1819A	676-0013-701	Q31	Flash Voltage Switch
MSB1218A	676-0013-700	Q320	Diversity LNA Bias
MRF9411	676-0003-618	Q321	Diversity LNA
MMBT918	676-0003-634	Q350	IF Amplifier Diversity RX
MSB1218A	676-0013-700	Q360	1st LO Amplifier Diversity RX
MRF9411	676-0003-618	Q361	1st LO Amplifier Diversity RX
MMBT918	676-0003-634	Q370	2nd LO Supply Switch
MJD42C	676-0002-603	Q40	9.6 V Regulator
MMBT3904	676-0003-658	Q41	9.6 V Regulator
MUN5213T1	676-0013-046	Q410	SCI Control Switch
MMBT4403	676-0003-612	Q50	5.5 V Regulator
MMBT4403	676-0003-612	Q51	5.5 V Regulator
MSB1218A	676-0013-700	Q510	Transmitter Driver Active Bias
MMBT3904	676-0003-658	Q52	5.5 V Regulator
MRF9411	676-0003-618	Q520	Transmitter Driver
MSA2111	676-0003-640	Q550	Buffer/Amp for Transmitter Driver
MUN5213T1	676-0013-046	Q600	TX_Enable
MMBT3904	676-0003-658	Q620	9.6PTx Antenna Switch
MMBT3904	676-0003-658	Q630	Power Control
MJD42C	676-0002-603	Q640	Power Control
MMBT3904	676-0003-658	Q650	Power Control
MMBT3904	676-0003-658	Q660	Power Control
MRF5812	676-0003-604	Q665	Transmitter 250 mW
MRF5003	676-0006-450	Q670	3 W Predriver
MRF5015	676-0006-150	Q680	15W Driver

TRANSISTOR, DIODE, AND IC FUNCTIONS (Continued)

RULE PART NUMBER: 2.1033 c (10)

<u>Manufacturer Part#</u>	<u>JDT Part#</u>	<u>References</u>	<u>Function</u>
MRF650	676-0004-402	Q690	50 W Final
MSB1218A	676-0013-700	Q70	Negative Voltage Regulator
MSB1218A	676-0013-700	Q71	Negative Voltage Regulator
MSB1218A	676-0013-700	Q72	Negative Voltage Regulator
MSD1819A	676-0013-701	Q73	Negative Voltage Regulator
MSD1819A	676-0013-701	Q74	Negative Voltage Regulator
MSD1819A	676-0013-701	Q805	Cap Multiplier on VCO
MUN5114T1	676-0013-032	Q820	VCO Pin Shift
MUN5213T1	676-0013-046	Q821	VCO Pin Shift
MMBT4403	676-0003-612	Q90	Main RX enable
NE85633	676-0003-636	Q900	VCO
NE85633	676-0003-636	Q902	VCO Amplifier
NE85633	676-0003-636	Q904	VCO Cascode Amplifier
NE85633	676-0003-636	Q906	VCO Buffer Amplifier
MUN5213T1	676-0013-046	Q91	Main RX enable
MMBT4403	676-0003-612	Q92	Diversity RX enable
MUN5213T1	676-0013-046	Q93	Diversity RX enable
MMBT4403	676-0003-612	Q94	TX Pre-Transmit Enable
MUN5213T1	676-0013-046	Q95	TX Pre-Transmit Enable
LP2951	644-2003-067	U10	5.0 V Regulator
MC14053B	644-3016-053	U110	Mod IN Narrow/Wide Band Switch
MC33172D	644-2019-017	U120	Audio Out Amp Main RX
MC33464	644-MC33464-	U20	MicroController Reset
MC33172D	644-2019-017	U208	Audio Out Amp Diversity RX
LRMS-2MH	644-0007-018	U250	First Mixer Main RX
SA676DK	644-2002-037	U260	IF IC Main RX
LRMS-2MH	644-0007-018	U350	First Mixer Diversity RX
SA676DK	644-2002-037	U360	IF IC Diversity RX
MC33172D	644-2019-017	U40	5.5, 9.6 V Regulator
MC74HC125	644-3766-125	U410	SCI Control
MC68HC908AZ60	644-5008-060	U420	MicroController
MC14053B	644-3016-053	U430	SPI Controller
LM50	644-2032-007	U440	Temp Sensor
MC33172D	644-2019-017	U450	Filter Adjust/ RSSI Compensation Voltage Amp
MC33172D	644-2019-017	U460	Filter Adjust/ RSSI Compensation Voltage Amp
MC33172D	644-2019-017	U600	Power Control
MC14051B	644-3016-051	U80	Negative Voltage Shift for VCO
SA7025DK	644-3954-027	U850	Synthesizer IC
SA676DK	644-2002-037	U860	IF IC Diversity RX
MC33172D	644-2019-017	U880	Modulation Input Amplifier
AD8403	644-0004-212	U890	Digital Pots (Mod Balance, Deviation Adj., P Cntrl)
AD8403	644-0004-212	U890	Fractional Spur Adjust
RO49PB38	621-0004-916	Y420	4.9152 MHz Microcontroller Crystal
618-7009-521	618-7009-521	Y890	17.5 MHz Temp. Comp. Crystal Oscillator (TCXO)

TRANSISTOR, DIODE, AND IC FUNCTIONS (continued)

RULE PART NUMBER: 2.1033 c (10)

GEMINI MODEM

Reference designator	Function	Type
D1	Diode,Dual Switching Sot-23	BAV70LT1
D2	Diode,Schotty Rectifier 1a 30v	MBRS130LT3
D3	Diode,Dual Switching Sot-23	BAV70LT1
D4	Diode,Schotty Rectifier 1a 30v	MBRS130LT3
D5	Diode,Dual Switching Sot-23	BAV70LT1
DS1	Led,3mm,Bicolor, 4 Stack	591-3001-1XX
DS2	Led,3mm,Bicolor, 4 Stack	591-3001-1XX
U1	Flash EEPROM Tsop 32 Pin 4 Megabit (Tsop-40)	AT29C040A-10TI
U2	RAM,CMOS,32K X 8, -40/85, SOP-28	TC55257DFL-85L
U3	Micropower Low Dropout Regulator With Shutdown	LT1129IST-3.3
U4	Dual D Type Flip-Flop So-14	74HC74AD
U5	5v Supervisory Circuits IC S0-8	ADM705AR/ MAX705ESA
U6	MICROPROCESSOR 10 Mhz QFP-100	Z84C1510FEC
U7	1.5a,500khz Stepdown Switching Regulat(S0-8)	LT1375IS8-5
U8	Octal Bidirectional Transceiver Sol-20	74LCX245
U9	Ic Octal3-St Sol-20	MC74LCX244DW
U10	Quad-Op Amp So-14	TLC2274I
U11	Stereo Codec Ssop-24	PCM3002E
U12	ADC 4 Channel, Tssop-16	AD7811YRU
U13	Digital Signal Processor	XC56303PV80
U14	Micropower Low Dropout Regulator With Shutdown	LT1129IST-3.3
U15	4 Drivers/4 Receivers Rs232 (Sol-24)	LT1134AISW
U16	MICROPROCESSOR 10 Mhz QFP-100	Z84C1510FEC
U17	4 Drivers/4 Receivers Rs232 (Sol-24)	LT1134AISW
U18	Hex Inverter Cmos(So-14)	74HCT04AD
U19	Quad 2-Input Or Gate (S0-14)	MC74VHC32AD
U20	Hex Inverter (So-14)	74VHC04
U21	MICROPROCESSOR 10 Mhz QFP-100	Z84C1510FEC
U22	4 Drivers/4 Receivers Rs232 (Sol-24)	LT1134AISW
X1	OSCILLATOR H-CMOS SMD 5V 19.6608mhz	F4101R
X2	OSCILLATOR 3.3V SMD 3.3V 12.288mhz	F4100R
G-8	GSM Receiver OEM board Ashtech (Orbitstar)	GPS G-8 OEM

TRANSMITTER TUNE UP PROCEDURE

RULE PART NUMBER: 2.1033 c (9)

TRANSMITTER TUNE UP PROCEDURE

The output power is controlled by a digital potentiometer which controls the supply voltage to the 250mW buffer/amp. The MDP Transceiver has a tuning procedure built into the software. The following instructions summarize the procedure for tuning the output power.

1. Connect the transceiver to be aligned to a DC power source capable of supplying 10 amps. Connect the output of the transceiver through a watt meter capable of measuring 50 Watts (10W for low power unit) and into a 50 ohm dummy load.
2. From the **Utilities** menu of the MDP 6000 Programmer software select **Tune Radio**. This brings up a box listings all possible tune-up parameters. Click in the box next to **Power Out Adjust**.
3. The transmitter keys up at the low end of the band and prompts the user to use the page-up and page-down keys to set the power to 40 Watts (10W for low power unit). The page-up, page-down keys vary the DAC value of the digital potentiometer. When complete the user clicks on OK, the DAC value is automatically stored. The software loads the next frequency to be set.
4. This process is repeated at four points across the band. Once the DAC value is determined for these four frequencies the processor interpolates the DAC value for frequencies in between the calibrated frequencies. This ensures equal power output across the entire RF band from 403-512MHz.

Deviation is controlled by a digital potentiometer which adjusts the amplitude of the modulating signal. The MDP Transceiver has a tuning procedure built into the software. The following instructions summarize the procedure for tuning the frequency deviation.

1. Connect the transceiver to be aligned to a DC power source capable of supplying 10 amps. Connect the output of the transceiver through a 50 ohm dummy load and into a modulation analyzer. Input a 880 mVrms, 1 KHz sine wave into the TX Mod input.
2. From the **Utilities** menu of the MDP 6000 Programmer software select **Tune Radio**. This brings up a box listings all possible tune-up parameters. Click in the box next to **Deviation Adjust**.
3. The transmitter keys up at the low end of the band and prompts the user to use the page-up and page-down keys to set the deviation to 5 KHz. The page-up, page-down keys vary the DAC value of the digital potentiometer. When complete the user clicks on OK, the DAC value is automatically stored. The software loads the next frequency to be set.
4. This process is repeated at four points across the band. Once the DAC value is determined for these four frequencies the processor interpolates the DAC value for frequencies in between the calibrated frequencies. This ensures constant deviation across the entire RF band from 403-512 MHz.

Note: The final deviation adjust is set on the Gemini modem which also has a digital potentiometer controlling the amplitude of the modulating signal before it reaches the MDP board. This deviation level is set to 4.0 KHz for 25 KHz channels and 2.5 KHz for 12.5 KHz channels with a 1 KHz modulating tone.

INSTRUCTION BOOK

RULE PART NUMBER: 2.1033 c (10)

The attached Service Manual for the GEMINI/PD product is a preliminary version.

NAME OF TEST: Transmitter Rated Power Output

RULE PART NUMBER: 2.1033 c (6)(7) and 2.1046 (a)

TEST RESULTS: See results below

TEST CONDITIONS: Standard Test Conditions, 25 C

TEST EQUIPMENT: Attenuator, BIRD Model / 100-A-MFN-20 / 20 dB / 100 Watt
Attenuator, BIRD Model / 50-A-MFN-03 / 3 dB / 50 Watt
Digital Voltmeter, Fluke Model 8012A
DC Power Source, Model HP6024A
Power Meter, HP 436A

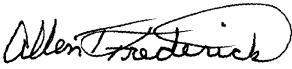
PERFORMED BY:  DATE: 9/30/98
Allen Frederick

TEST SET-UP:

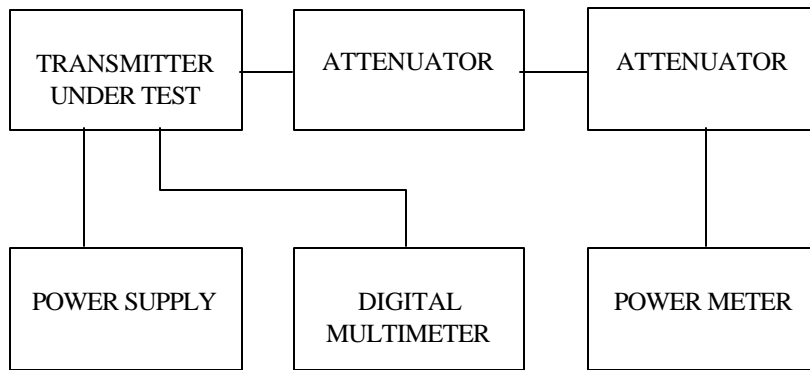

TEST RESULTS:

Frequency (MHz)	DC Voltage at Final (VDC)	DC Current into Final (ADC)	DC Power into Final (W)	RF Power Output (W)
450.000	13.1	5.47	71.66	50.0
450.000	13.1	2.9	37.99	13.0

NAME OF TEST: Transmitter Occupied Bandwidth

RULE PART NUMBER: 2.201, 2.202, 2.1033 c (14), 2.1049 (h), 2.1041

Necessary Bandwidth Measurement:

The Gemini/PD modem generates Differential Gaussian Frequency Shift Keying (DGFSK). The main CPU processes incoming binary data, applying Forward Error Correction (FEC), interleaving and scrambling, from it, generates an NRZ signal that is fed to the DSP processor for encoding and pulse shaping. That digital signal is digitally filtered (Gaussian pulse shaping) by the DSP then fed to the CODEC for digital to analog conversion. This DGFSK waveshape applied to the FM modulator will then produce a compact RF spectrum, when using proper frequency deviation, to fit inside the restrictive masks inherent to the intended channel bandwidth.

The necessary bandwidth calculation for this type of modulation is not covered by paragraphs (1), (2) or (3) from 2.202(c). Therefore, the approach outlined in (2.202(c)(4)) is applicable in this case.

The measurement explanations are provided in in the following 4 pages.

Necessary Bandwidth Measurement:

Peak deviation = ± 4 kHz
Modulator signal bit rate 19200 bps,

$B_n = 14980$ Hz

The corresponding emission designator prefix for necessary bandwidth = 15K0

Table 1 - Measurements results for the Gemini unit , 9600 bps BT= .3, 16000bps BT=.4 and 19200 bps BT= .3 and frequency deviations set to obtain specified values .

unit's software settings	measured data (kHz)		Emission designator
bit rate (data settings)	freq. dev	99% occupied BW	
9600 BT= .3	2.5	8.54 KHz	8K60
16000 BT= .4	4.0	15.26 KHz	15K3
19200 BT= .3	4.0	14.98 KHz	15K0

Spectrum efficiency (90.203 (j)(3)) requirement: 4800 bits per second per 6.25 kHz of channel bandwidth.

19200bps=4*4800bps, meets efficiency requirement for 25 kHz channel

9600bps=2*4800bps, meets efficiency requirement for 12.5 kHz channel

Occupied Bandwidth Measurement

1. Theory of Measurement

The way to define the **Occupied Bandwidth** is “the frequency bandwidth such that, below its lower and above its upper frequency limits, the mean powers radiated are each equal to 0.5 percent of the total mean power radiated by a given emission” (FCC 2.202), so the mathematics for it are:

$$0.005*TP=P_{(f1)}=\int_0^{f1} PSD_{(f)}df$$

$$0.995*TP=P_{(f2)}=\int_0^{f2} PSD_{(f)}df$$

$$OBW=f2-f1$$

where TP (total mean power) is

$$TP=\int_0^{+\infty} PSD_{(f)}df=(1/t)\int_{-\infty}^{+\infty} |z(t)|^2 dt$$

and PSD (power spectral distribution) is

$$PSD_{(f)}=|Z_{(f)}|^2+|Z_{(-f)}|^2 \quad 0 \leq f < 4$$

and expresses the positive frequency representation of the transmitter output power for z(t) signal.

By applying these mathematics to the measurements, it is possible to measure the Occupied Bandwidth using the RF signal’s trace provided by a digital spectrum analyzer and processed further by computational methods.

The Occupied Bandwidth measurement is in two parts relatively independent of each other. The first gives the RF spectrum profile, and the second calculates the frequency limits and they result in the Occupied bandwidth. While the first involves RF measurement instrumentation, the second is strictly a computational part related to measured trace.

Getting an equally-sampled RF power spectrum profile requires a Digital Spectrum Analyzer. In addition to the instrument’s usual requirements, a special attention must be paid to the analyzer’s span (bandwidth to be investigated).

This bandwidth must be large enough to contain all the power spectral components created by the transmitter. The frequency step, where the samples are picked, is directly dependent on the span’s value.

$$\Delta f = \text{span/number of points displayed}$$

The frequency resolution will determine the measurement accuracy. So for greater accuracy, less bandwidth will give better values because of the constant number of points that can be displayed. Taking into account the purpose of transmitter, an acceptable balance can be set. For channel-limited transmitters all the power spectral components can be found in main channel and a number of adjacent channels, upper and lower, from the main channel. The relation between these two requirements, number of channels and accuracy, is depicted by:

$$a(\%) \cong (2 \cdot k \cdot n / N) \cdot 100,$$

where a is desired accuracy, in percentage units, n is the number of channels in span, including main channel, N is displayed number of points and k= (authorized bandwidth) /channel bandwidth.

For usual spectrum analyzers $N \cong 500$, $k=0.8$ (20/25) for 25kHz channel transmitters or $k=0.9$ (11.25/12.5) for 12.5kHz channel transmitters, so $a \cong n/2.5$ (%) can estimate the expected precision for measurement.

All other requirements for spectrum analyzer are the same as they are for mask compliance determination.

The second part has computational requirements related to the trace's values processing.

The following operations must be performed over the trace's (x,y) points:

1. convert y value in dBm (or the analyzer's display y units) units power sample
2. convert y value in W units power sample,
3. add to total power every power sample and get total power value (W units for total power)
4. set low level (0.5% *total power)
5. detect x1-sample which pass low level (convert f1 integrals to sample summing)
6. convert (x1-1)-sample value in frequency units (the x-sample is already in occupied bandwidth),
7. store first frequency correspondent to (x1-1)-sample
8. set up level (99.5% *total power)
9. detect x2-sample which pass up level (convert f2 integrals to sample summing)
10. convert (x2)-sample value in frequency units (the x-sample is now out of occupied bandwidth),
11. store second frequency correspondent to (x2)-sample
12. read the frequency difference , this is **Occupied Bandwidth**, and display the result.

Standard calculation precision is all that is required. The main error factor being the y display resolution is covering calculation precision.

The absolute error for this measurement is $-0/+2\%$. It is not possible to decrease span bandwidth under 2 channels bandwidth because this will affect the significance of result by cutting off the power's spectral distribution edges.

2. Dataradio's Measurement Set-Up

For the above requirements, the occupied bandwidth of a transmitter was measured using an IFR AN930 A spectrum analyzer having adequate macrofunction to perform computational part. The number of power spectrum samples (N) is 500. Because in test results frequency deviation was also a parameter, measurement instruments were completed with an IFR COM-120 B for frequency deviation determination.

The measurement set-up is:

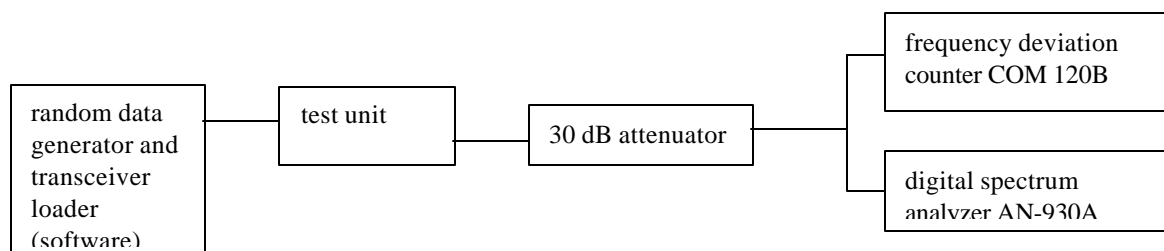

The AN-930 A spectrum analyzer's parameters are adjusted as follow:

- total span is adjusted at $2.8 \times$ channel space this means 70 kHz for 25 kHz channel and 35 kHz for 12.5 kHz channel. This setting will result in frequency sample step (f) of 140 Hz for 25 kHz channel and 70 Hz for 12.5 kHz channel.
- RBW is set to 300 Hz, this is better than 1% of total span bandwidth.
- video filter is set to 1Khz;
- all other parameter of the instrument are automatically adjusted to obtain calibrated measurements (sweep time 4s).
- central frequency and reference level are adjusted to the unmodulated carrier frequency and level.

The AN 930 A spectrum analyzer's Occupied Bandwidth macrofunction input parameters are:

- central frequency, same as above, the unmodulated carrier frequency.
- channel spacing, 25 kHz or 12.5 kHz according to the signal,
- percentage of Occupied Bandwidth 99%.

The macro operations are:

- the trace is read;
- follow all the computational steps required.

Each sample is converted from dBm to mW and add to total power (tpow) variable. Then are computed the limits of 0.5% and 99.5% by using variable remaining percent (RemPer), and in same time are stored sample number where these two percentage meet. Then are assigned to the markers the correspondent frequencies of numbers.

- Occupied Bandwidth is then displayed as Delta mode marker (difference between markers).
- return to operational mode.

NOTE 1: The computational part could be performed on every device featured with data acquisition.

NOTE 2: An approximation of the occupied bandwidth calculation can be performed by measuring at the points at which the spectrum, measured with a spectrum analyzer of 300 Hz resolution bandwidth, is 25dB down relative to the unmodulated carrier reference level.

Using this same measurement procedure the occupied bandwidth was determined for 16000bps and 9600bps.

NAME OF TEST: Transmitter Occupied Bandwidth
GEMINI Modem at 9600 bps
In Support of Emission Designator **8K60F1D**

RULE PART NUMBER: 2.201, 2.202, 2.1033 c (14), 2.1049 (h), 2.1041, 90.209 (b)(5), 90.210 (d)

MINIMUM STANDARD: Mask D
Sidebands and Spurious [Rule 90.210 (d)]
Authorized Bandwidth = 11.25 kHz [Rule 90.209(b) (5)]
Fo to 5.625 kHz Attenuation = 0 dB.
>5.625 kHz to 12.5 kHz Attenuation= 7.27(f_d -2.88kHz) dB.
>12.5 kHz Attenuation = Lesser of: 50+10log₁₀(P)
OR 70 dB

Attenuation = 0 dB at Fo to 5.625 kHz
Attenuation = 20 dB at 5.625 kHz and 70 dB at 12.5 kHz
Attenuation = 67 dB at > 12.5 kHz (50 Watts)
Attenuation = 60 dB at > 12.5 kHz (10 Watts)

TEST RESULTS: Meets minimum standard (see data on the following pages)

TEST CONDITIONS: Standard Test Conditions, 25 C

TEST EQUIPMENT: Attenuator, BIRD Model / 100-A-MFN-20 / 20 dB / 100 Watt
Attenuator, BIRD Model / 50-A-MFN-03 / 3 dB / 50 Watt
Digital Voltmeter, Fluke Model 8012A
DC Power Source, Model HP6024A
Modulation Analyzer, Model HP8901A
Spectrum Analyzer, Model HP8563E
Plotter, HP7470A

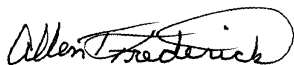

PERFORMED BY: _____ DATE: 10/21/98
Allen Frederick

TEST SET-UP:

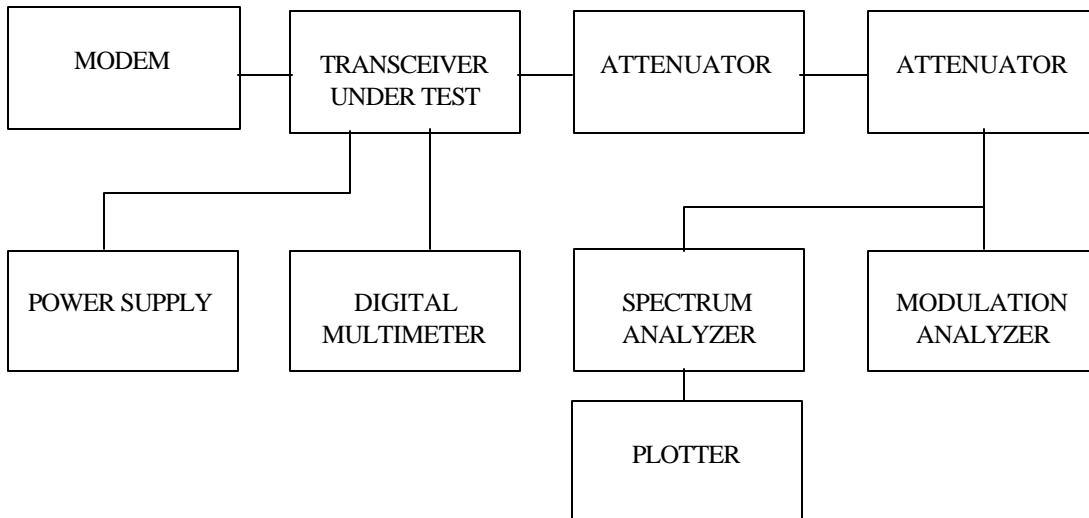

NAME OF TEST: Transmitter Occupied Bandwidth (Continued)
GEMINI Modem at 9600 bps
In Support of Emission Designator **8K60F1D**

MODULATION SOURCE DESCRIPTION:

The Gemini/PD modem generates Differential Gaussian Frequency Shift Keying (DGFSK). This digital modulation scheme is produced by the main CPU in conjunction with the DSP processor.

The main CPU processes incoming binary data, applying Forward Error Correction (FEC), interleaving and scrambling, from it, generates an NRZ signal that is fed to the DSP processor for encoding and pulse shaping. That digital signal is digitally filtered (Gaussian pulse shaping) by the DSP then fed to the CODEC for digital to analog conversion. This DGFSK waveshape applied to the FM modulator will then produce a compact RF spectrum, when using proper frequency deviation, to fit inside the restrictive masks inherent to the intended channel bandwidth.

The transmitter deviation level and digital filter cutoff frequency (which is based on the Gaussian “Bt” factor) are set according to the bit rate selected and channel bandwidth as follows:

Bit rate	Bt factor	Deviation	Occupied Bandwidth
9600 b/s	.3	± 2.5 KHz	8.6 KHz
16000 b/s	.4	± 4.0 KHz	15.3 KHz
19200 b/s	.3	± 4.0 KHz	15.0 KHz

TX Data Test Pattern:

The transmit “test data” pattern command produces a 2047 bit pseudo-random pattern. This pattern is generated by the internal software using the polynomial $X^{11}+X^9+1$ form and a 12-bit shift register. Initial value of the register is 111111111110 (FFE hex). The 2047 bit sequence is repeated thereafter as long is necessary to complete the test duration (55 sec). This pattern is applied to the DSP processor data input for encoding and pulse shaping as described above.

NECESSARY BANDWIDTH (Bn) CALCULATION

See Page 30 for emission designator determination.

The corresponding emission designator prefix for necessary bandwidth = **8K60**

TEST DATA: Refer to the following graphs:

MASK: D
SPECTRUM FOR EMISSION 8K60F1D
OUTPUT POWER: 2 Watts
9600 bps
PEAK DEVIATION = 2500 Hz
SPAN = 100 kHz

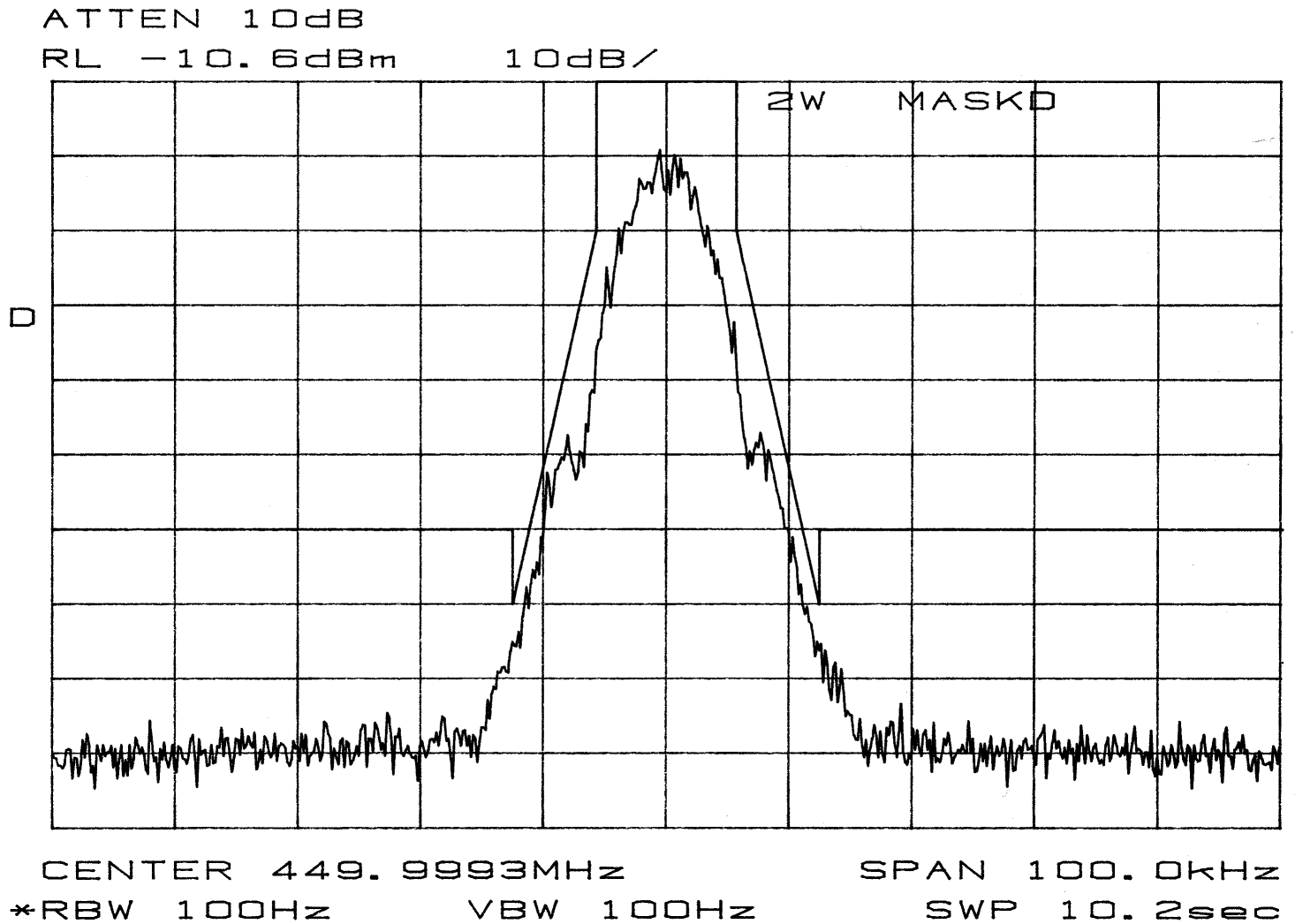

MASK: D
SPECTRUM FOR EMISSION 8K60F1D
OUTPUT POWER: 13 Watts
9600 bps
PEAK DEVIATION = 2500 Hz
SPAN = 100 kHz

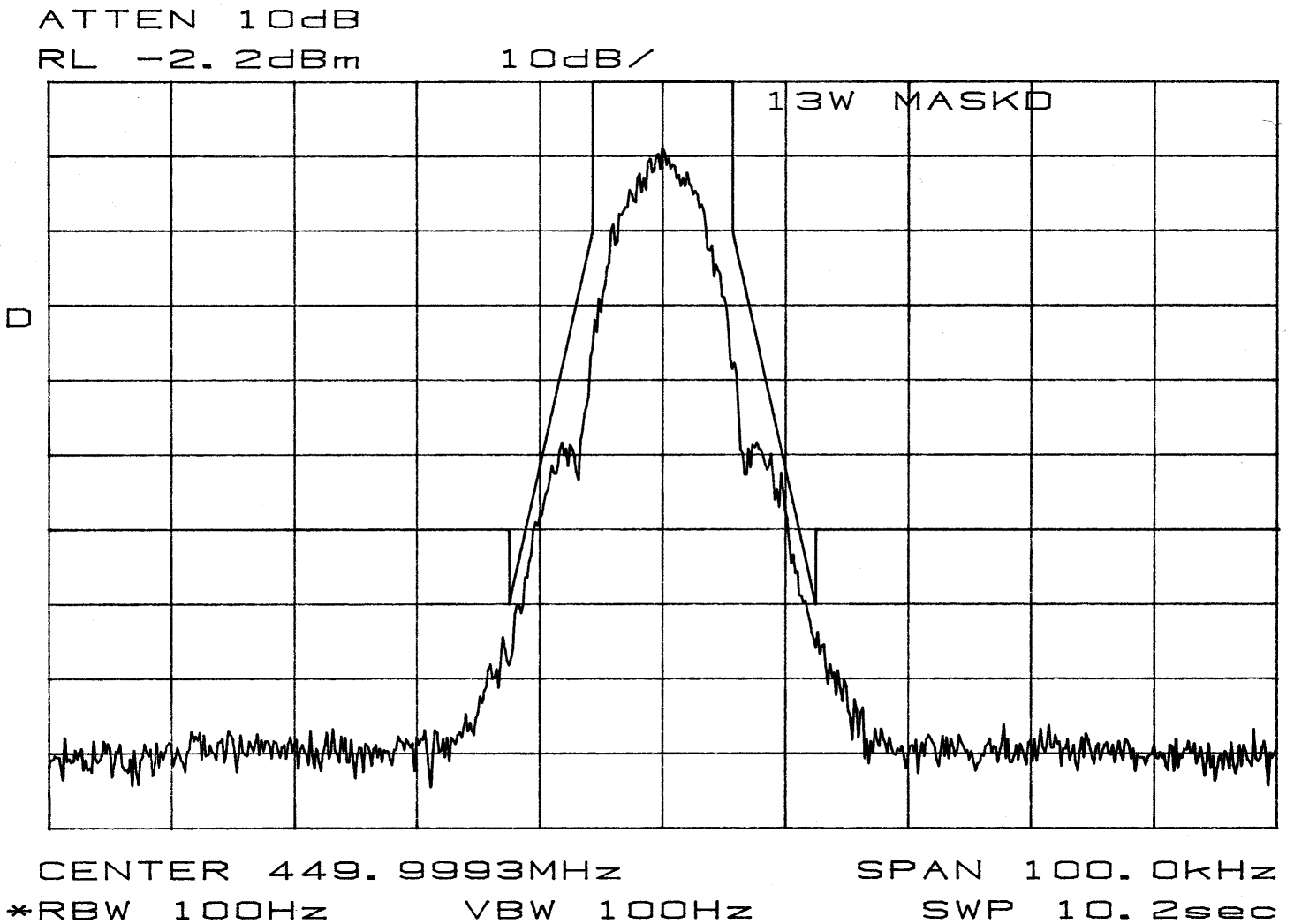

MASK: D
SPECTRUM FOR EMISSION 8K60F1D
OUTPUT POWER: 10 Watts
9600 bps
PEAK DEVIATION = 2500 Hz
SPAN = 100 kHz

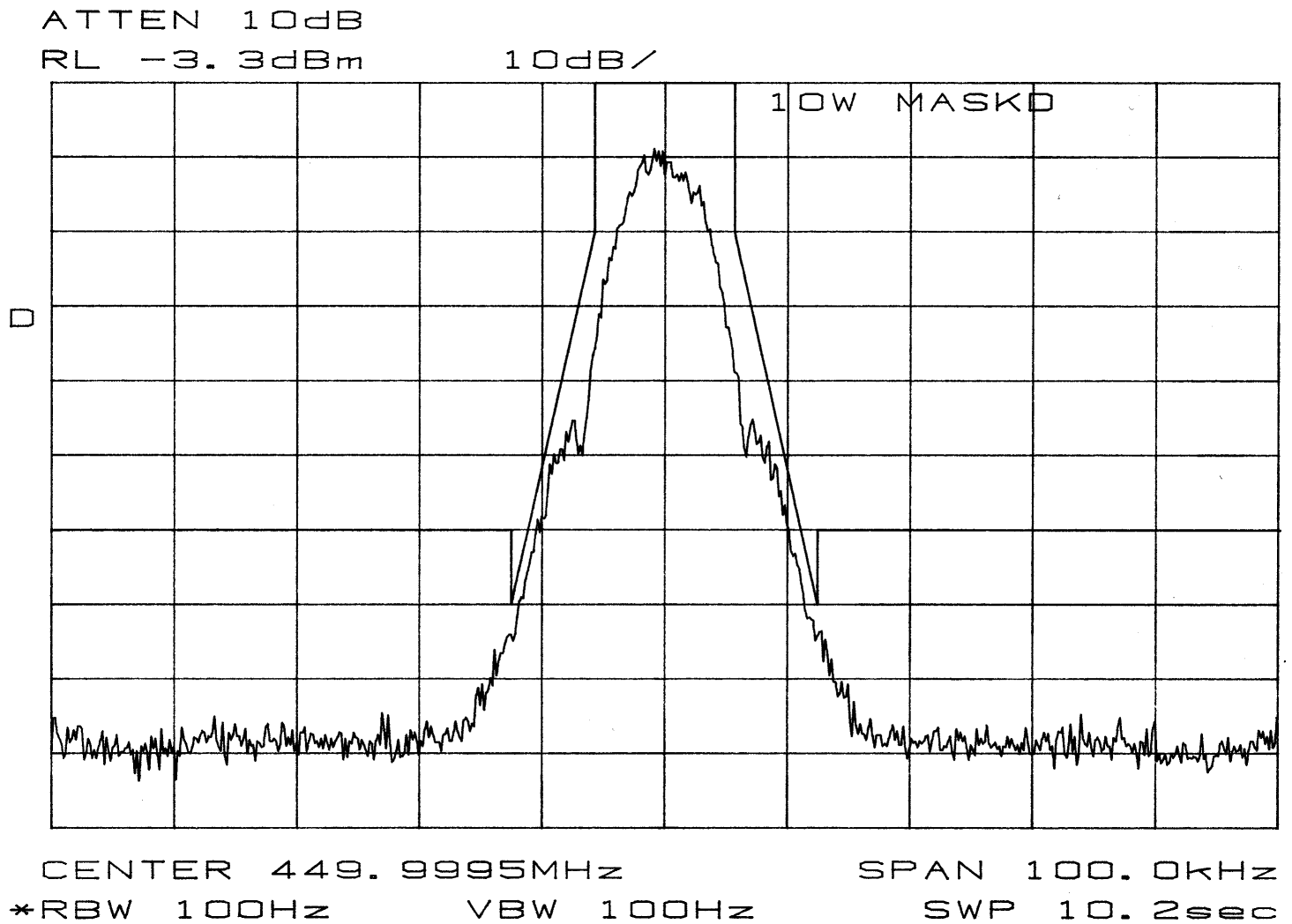

MASK: D
SPECTRUM FOR EMISSION 8K60F1D
OUTPUT POWER: 50 Watts
9600 bps
PEAK DEVIATION = 2500 Hz
SPAN = 100 kHz

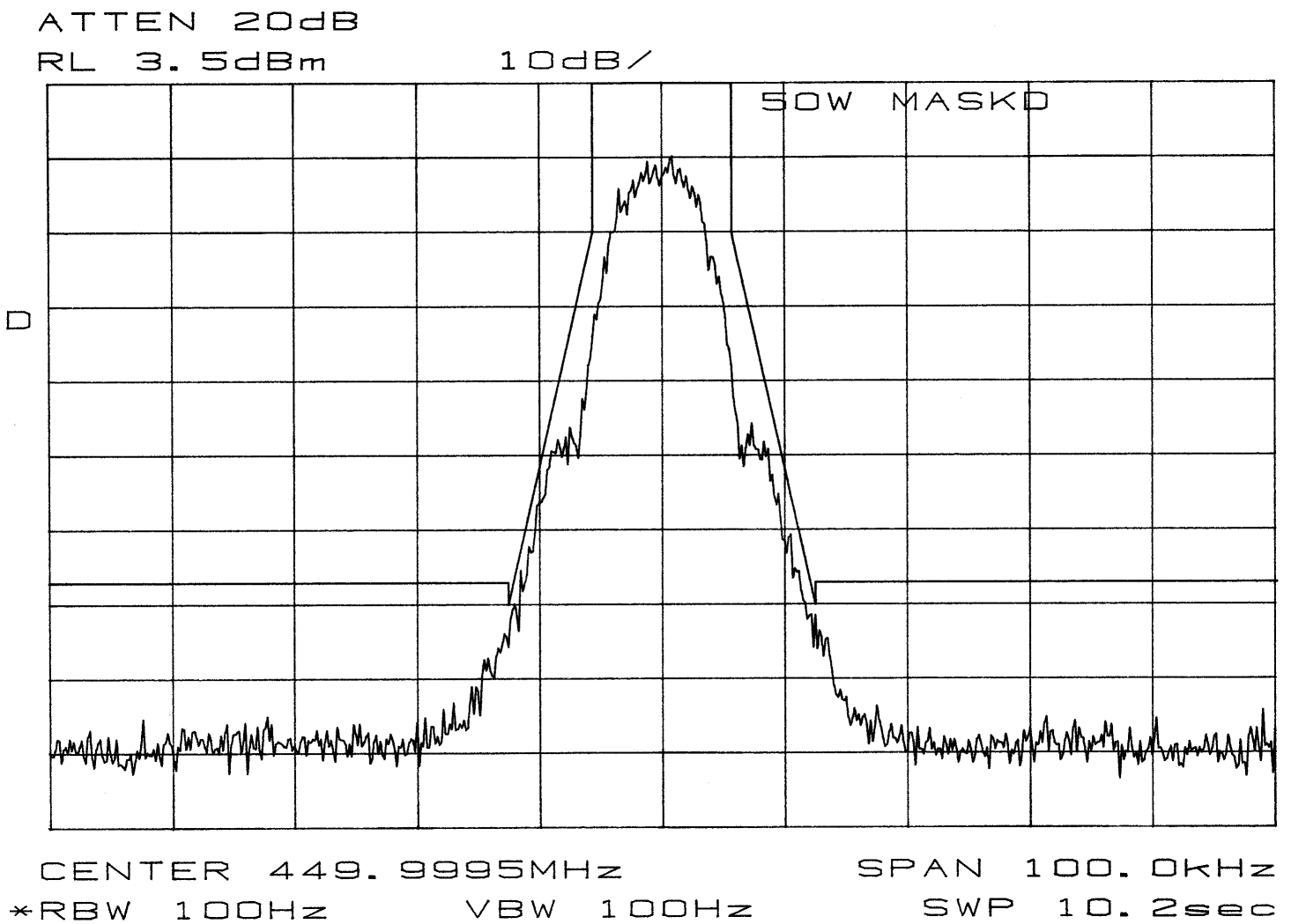

NAME OF TEST: Transmitter Occupied Bandwidth
GEMINI Modem at 16000 bps
In Support of Emission Designator **15K3F1D**

RULE PART NUMBER: 2.201, 2.202, 2.1033 c (14), 2.1049 (h), 2.1041, 90.209 (b)(5), 90.210 (b)

MINIMUM STANDARD: Mask B
Sidebands and Spurious [Rule 90.210 (b)]
Authorized Bandwidth = 20 kHz [Rule 90.209(b) (5)]
From Fo to 50% of Authorized BW Removed from Fo, down 0 dB.
From 50% to 100% removed, at least 25 dB.
From 100% to 250% removed, at least 35 dB.
Greater than 250% remove, at least $43 + 10\log_{10}(P)$ dB.

Fo to 10 kHz Attenuation = 0 dB
10 kHz to 20 kHz, Attenuation = 25 dB minimum
20 kHz to 50 kHz, Attenuation = 35 dB minimum
> 50 kHz, Attenuation = 60 dB minimum (50 watts)
> 50 kHz, Attenuation = 53 dB minimum (10 watt)

TEST RESULTS: Meets minimum standard (see data on the following pages)

TEST CONDITIONS: Standard Test Conditions, 25 C

TEST EQUIPMENT: Attenuator, BIRD Model / 100-A-MFN-20 / 20 dB / 100 Watt
Attenuator, BIRD Model / 50-A-MFN-03 / 3 dB / 50 Watt
Digital Voltmeter, Fluke Model 8012A
DC Power Source, Model HP6024A
Modulation Analyzer, Model HP8901A
Spectrum Analyzer, Model HP8563E
Plotter, HP7470A

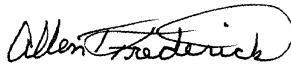

PERFORMED BY: _____ DATE: 10/21/98
Allen Frederick

TEST SET-UP:

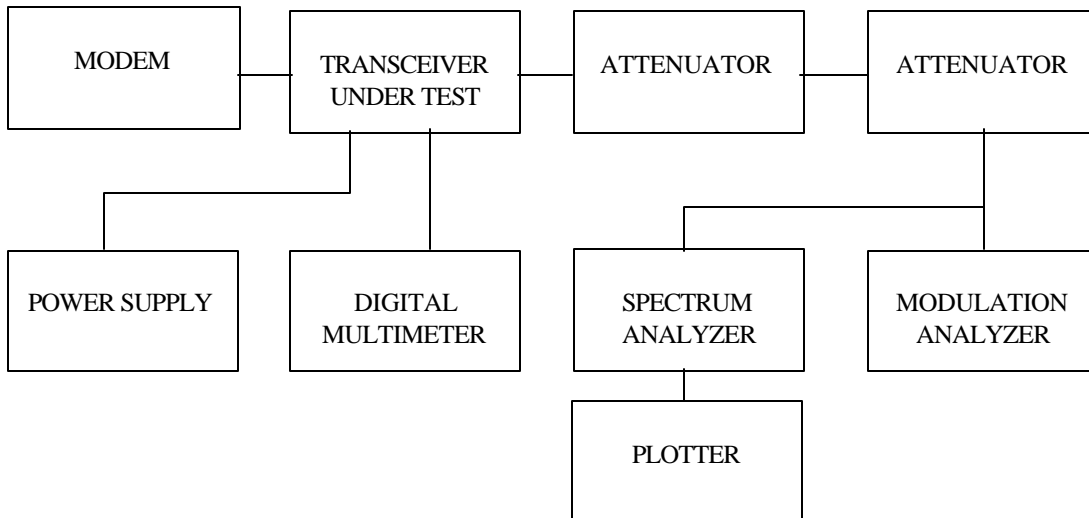

NAME OF TEST: Transmitter Occupied Bandwidth (Continued)
GEMINI Modem at 16000 bps
In Support of Emission Designator **15K3F1D**

MODULATION SOURCE DESCRIPTION:

The Gemini/PD modem generates Differential Gaussian Frequency Shift Keying (DGFSK). This digital modulation scheme is produced by the main CPU in conjunction with the DSP processor.

The main CPU processes incoming binary data, applying Forward Error Correction (FEC), interleaving and scrambling, from it, generates an NRZ signal that is fed to the DSP processor for encoding and pulse shaping. That digital signal is digitally filtered (Gaussian pulse shaping) by the DSP then fed to the CODEC for digital to analog conversion. This DGFSK waveshape applied to the FM modulator will then produce a compact RF spectrum, when using proper frequency deviation, to fit inside the restrictive masks inherent to the intended channel bandwidth.

The transmitter deviation level and digital filter cutoff frequency (which is based on the Gaussian “Bt” factor) are set according to the bit rate selected and channel bandwidth as follows:

Bit rate	Bt factor	Deviation	Occupied Bandwidth
9600 b/s	.3	± 2.5 KHz	8.6 KHz
16000 b/s	.4	± 4.0 KHz	15.3 KHz
19200 b/s	.3	± 4.0 KHz	15.0 KHz

TX Data Test Pattern:

The transmit “test data” pattern command produces a 2047 bit pseudo-random pattern. This pattern is generated by the internal software using the polynomial $X^{11}+X^9+1$ form and a 12-bit shift register. Initial value of the register is 111111111110 (FFE hex). The 2047 bit sequence is repeated thereafter as long is necessary to complete the test duration (55 sec). This pattern is applied to the DSP processor data input for encoding and pulse shaping as described above.

NECESSARY BANDWIDTH (Bn) CALCULATION

See Page 30 for emission designator determination.

The corresponding emission designator prefix for necessary bandwidth = **15K3**

TEST DATA: Refer to the following graphs:

MASK: B
SPECTRUM FOR EMISSION 15K3F1D
OUTPUT POWER: 2 Watts
16000 bps
PEAK DEVIATION = 4000 Hz
SPAN = 200 kHz

*ATTEN 20dB
RL -9.3dBm

10dB/

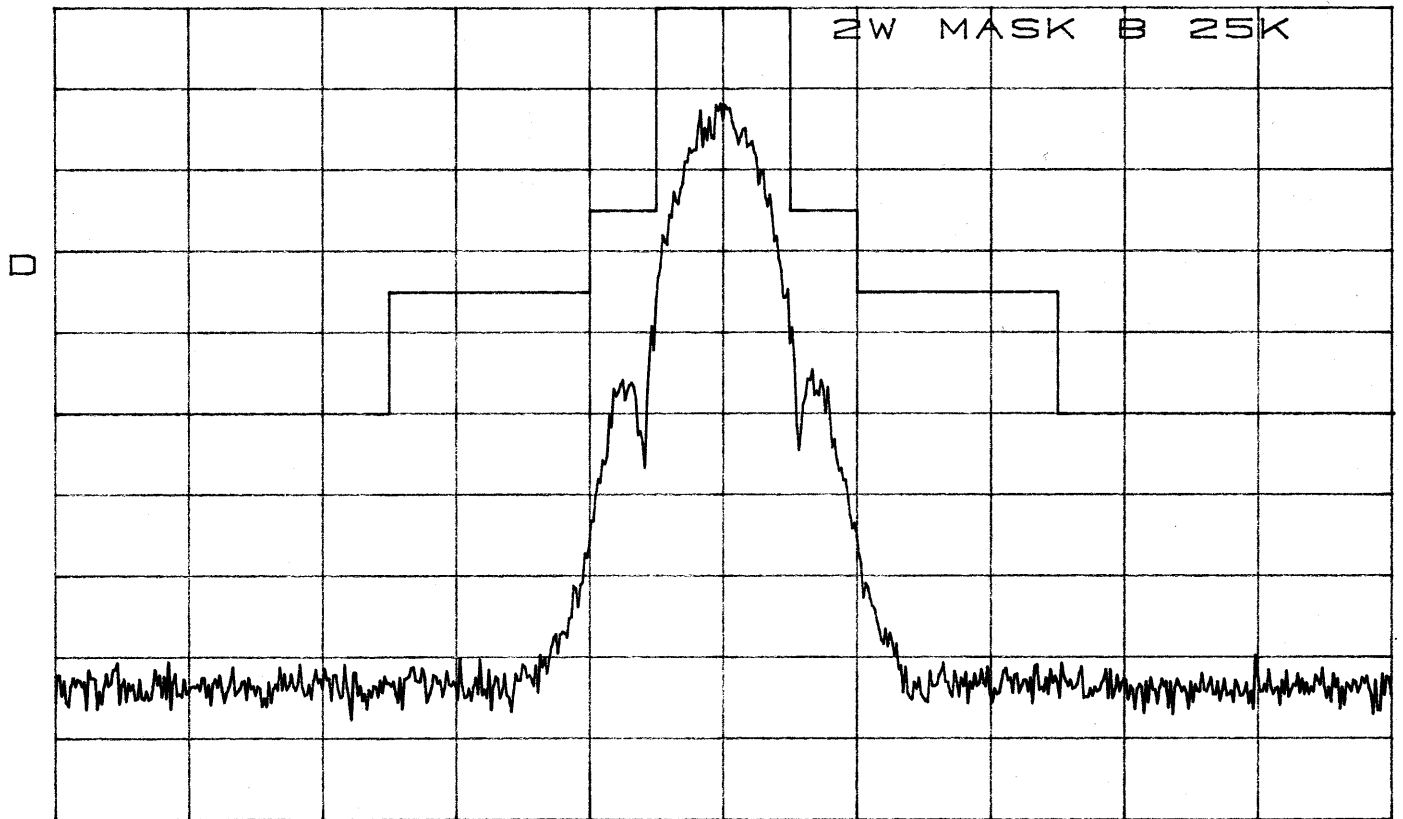

2W MASK B 25K

CENTER 449.9993MHz SPAN 200.0kHz
*RBW 100Hz VBW 100Hz SWP 20.3sec

MASK: B
SPECTRUM FOR EMISSION 15K3F1D
OUTPUT POWER: 13 Watts
16000 bps
PEAK DEVIATION = 4000 Hz
SPAN = 200 kHz

*ATTEN 20dB

RL -1.1dBm 10dB/

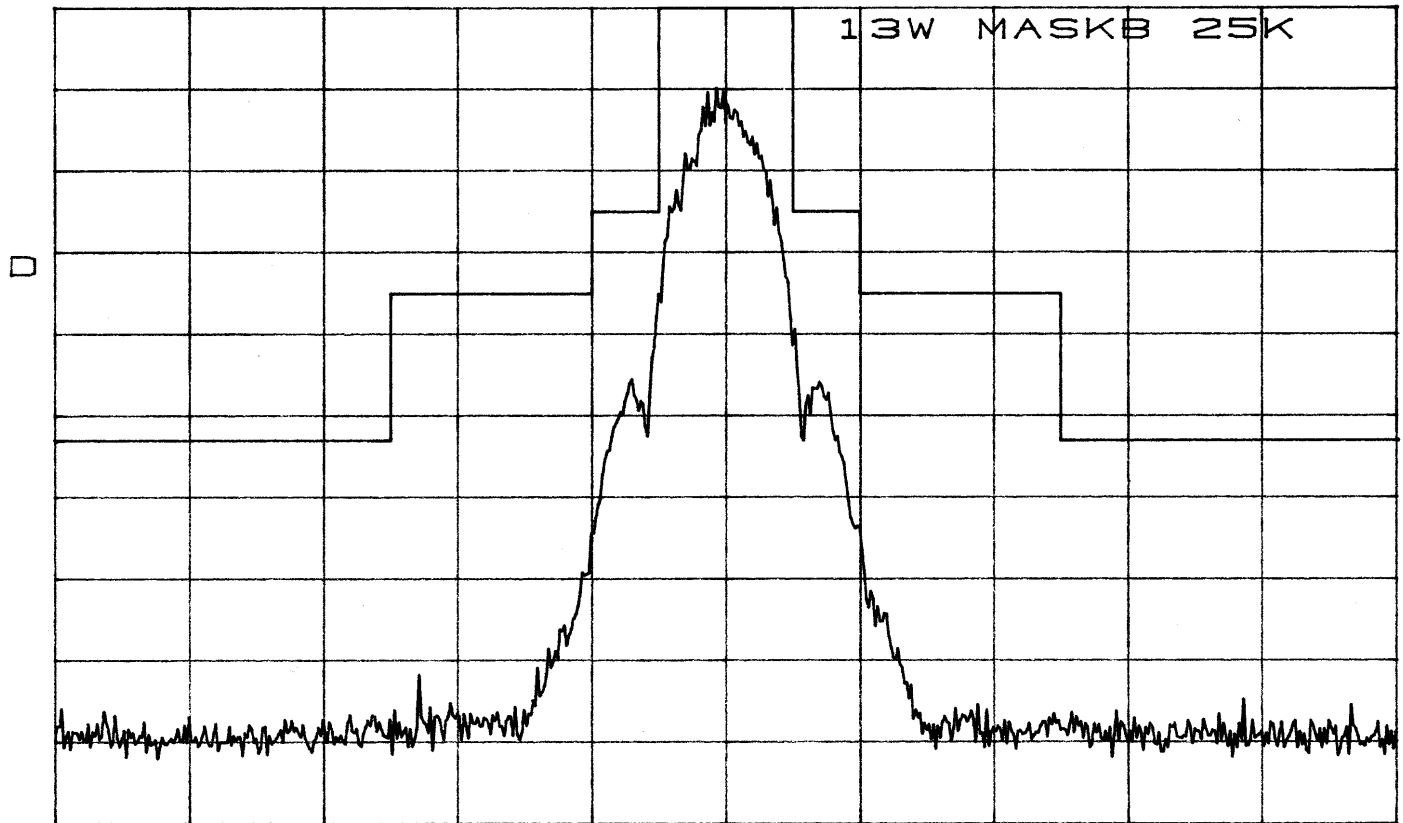

CENTER 449.9993MHz SPAN 200.0kHz
*RBW 100Hz VBW 100Hz SWP 20.3sec

MASK: B
SPECTRUM FOR EMISSION 15K3F1D
OUTPUT POWER: 10 Watts
16000 bps
PEAK DEVIATION = 4000 Hz
SPAN = 200 kHz

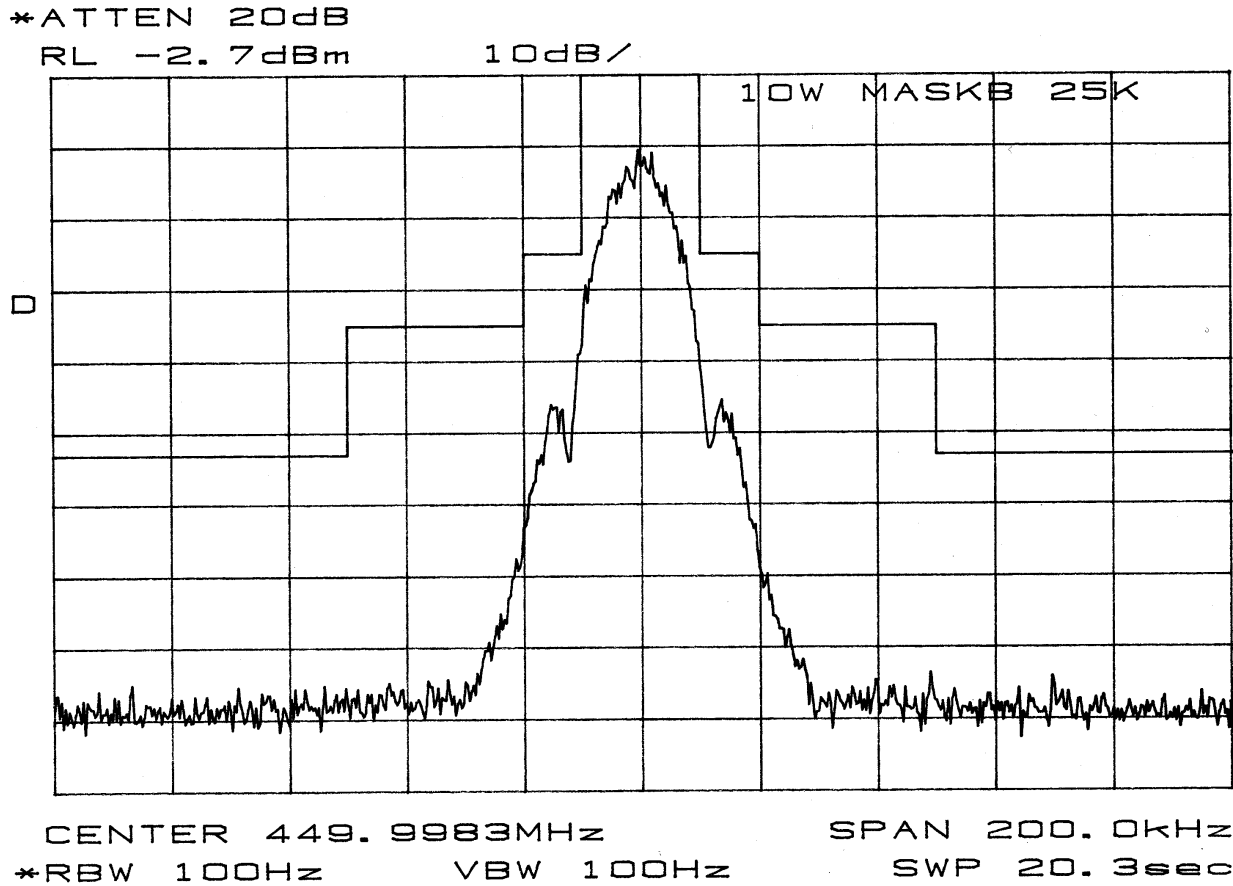

MASK: B
SPECTRUM FOR EMISSION 15K3F1D
OUTPUT POWER: 50 Watts
16000 bps
PEAK DEVIATION = 4000 Hz
SPAN = 200 kHz

*ATTEN 20dB
RL 4.7dBm

10dB/

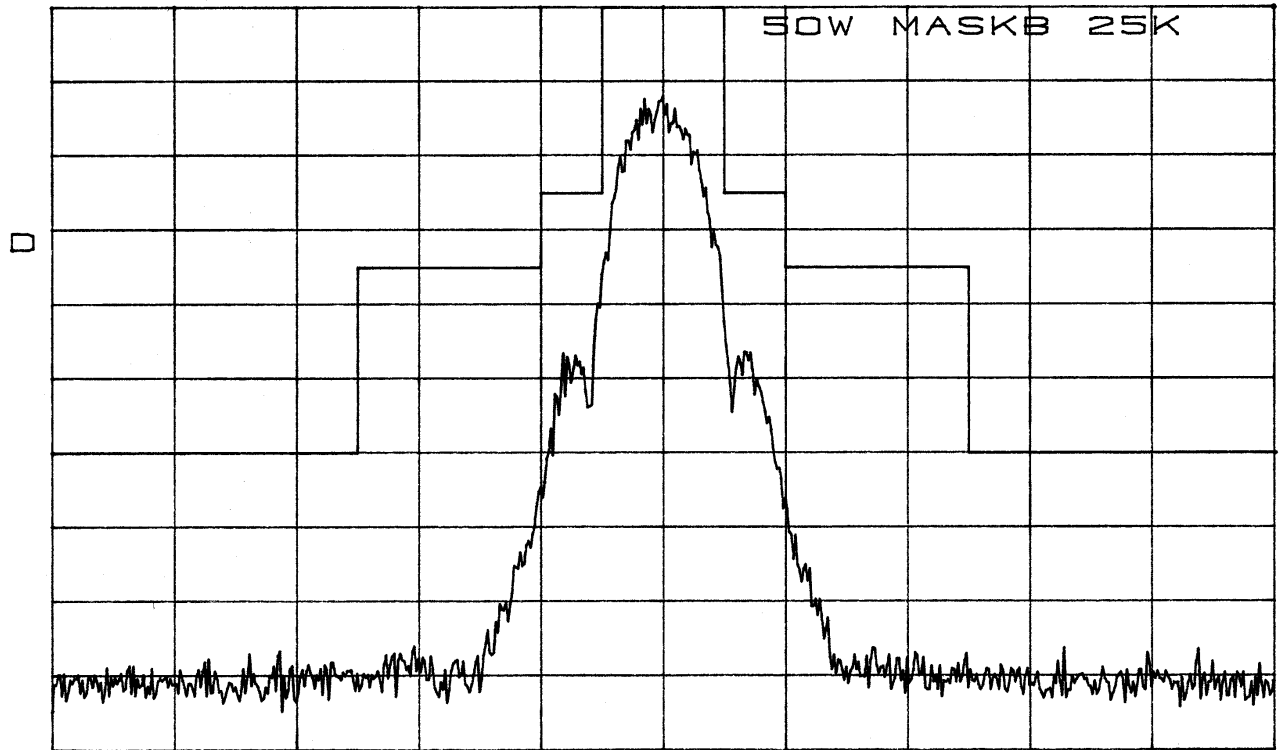

CENTER 449.9983MHz SPAN 200.0kHz
*RBW 100Hz VBW 100Hz SWP 20.3600

NAME OF TEST: Transmitter Occupied Bandwidth
GEMINI Modem at 19200 bps
In Support of Emission Designator **15K0F1D**

RULE PART NUMBER: 2.201, 2.202, 2.1033 c (14), 2.1049 (h), 2.1041, 90.209 (b)(5), 90.210 (b)

MINIMUM STANDARD: Mask B
Sidebands and Spurious [Rule 90.210 (b)]
Authorized Bandwidth = 20 kHz [Rule 90.209(b) (5)]
From Fo to 50% of Authorized BW Removed from Fo, down 0 dB.
From 50% to 100% removed, at least 25 dB.
From 100% to 250% removed, at least 35 dB.
Greater than 250% remove, at least $43 + 10\log_{10}(P)$ dB.

Fo to 10 kHz Attenuation = 0 dB
10 kHz to 20 kHz, Attenuation = 25 dB minimum
20 kHz to 50 kHz, Attenuation = 35 dB minimum
> 50 kHz, Attenuation = 60 dB minimum (50 watts)
> 50 kHz, Attenuation = 53 dB minimum (10 watt)

TEST RESULTS: Meets minimum standard (see data on the following pages)

TEST CONDITIONS: Standard Test Conditions, 25 C

TEST EQUIPMENT: Attenuator, BIRD Model / 100-A-MFN-20 / 20 dB / 100 Watt
Attenuator, BIRD Model / 50-A-MFN-03 / 3 dB / 50 Watt
Digital Voltmeter, Fluke Model 8012A
DC Power Source, Model HP6024A
Modulation Analyzer, Model HP8901A
Spectrum Analyzer, Model HP8563E
Plotter, HP7470A

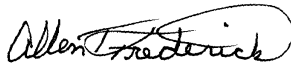

PERFORMED BY: _____ DATE: 10/21/98
Allen Frederick

TEST SET-UP:

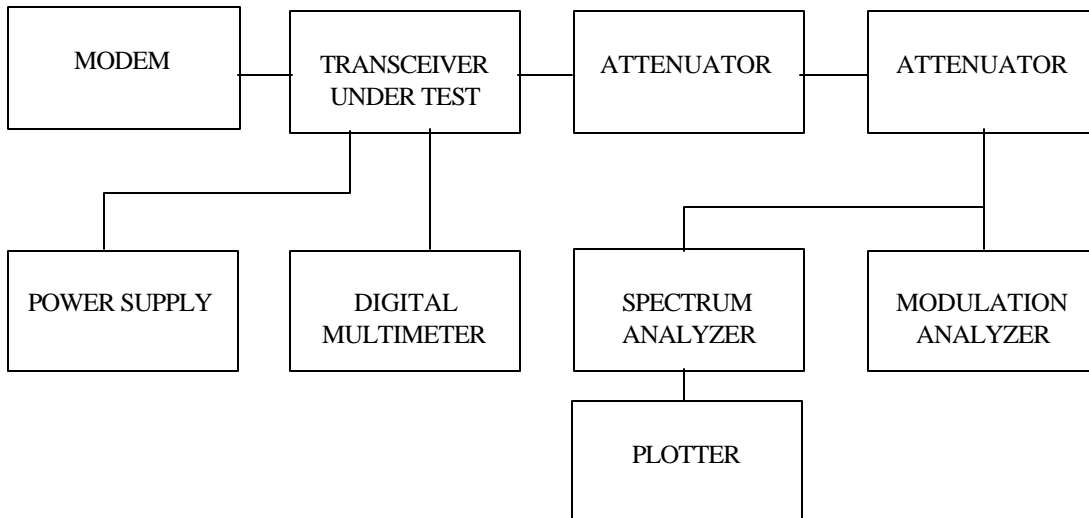

NAME OF TEST: Transmitter Occupied Bandwidth (Continued)
GEMINI Modem at 19200 bps
In Support of Emission Designator **15K0F1D**

MODULATION SOURCE DESCRIPTION:

The Gemini/PD modem generates Differential Gaussian Frequency Shift Keying (DGFSK). This digital modulation scheme is produced by the main CPU in conjunction with the DSP processor.

The main CPU processes incoming binary data, applying Forward Error Correction (FEC), interleaving and scrambling, from it, generates an NRZ signal that is fed to the DSP processor for encoding and pulse shaping. That digital signal is digitally filtered (Gaussian pulse shaping) by the DSP then fed to the CODEC for digital to analog conversion. This DGFSK waveshape applied to the FM modulator will then produce a compact RF spectrum, when using proper frequency deviation, to fit inside the restrictive masks inherent to the intended channel bandwidth.

The transmitter deviation level and digital filter cutoff frequency (which is based on the Gaussian “Bt” factor) are set according to the bit rate selected and channel bandwidth as follows:

Bit rate	Bt factor	Deviation	Occupied Bandwidth
9600 b/s	.3	± 2.5 KHz	8.6 KHz
16000 b/s	.4	± 4.0 KHz	15.3 KHz
19200 b/s	.3	± 4.0 KHz	15.0 KHz

TX Data Test Pattern:

The transmit “test data” pattern command produces a 2047 bit pseudo-random pattern. This pattern is generated by the internal software using the polynomial $X^{11}+X^9+1$ form and a 12-bit shift register. Initial value of the register is 111111111110 (FFE hex). The 2047 bit sequence is repeated thereafter as long is necessary to complete the test duration (55 sec). This pattern is applied to the DSP processor data input for encoding and pulse shaping as described above.

NECESSARY BANDWIDTH (Bn) CALCULATION

See Page 30 for emission designator determination.

The corresponding emission designator prefix for necessary bandwidth = **15K0**

TEST DATA: Refer to the following graphs:

MASK: B
SPECTRUM FOR EMISSION 15K0F1D
OUTPUT POWER: 2 Watts
19200 bps
PEAK DEVIATION = 4000 Hz
SPAN = 200 kHz

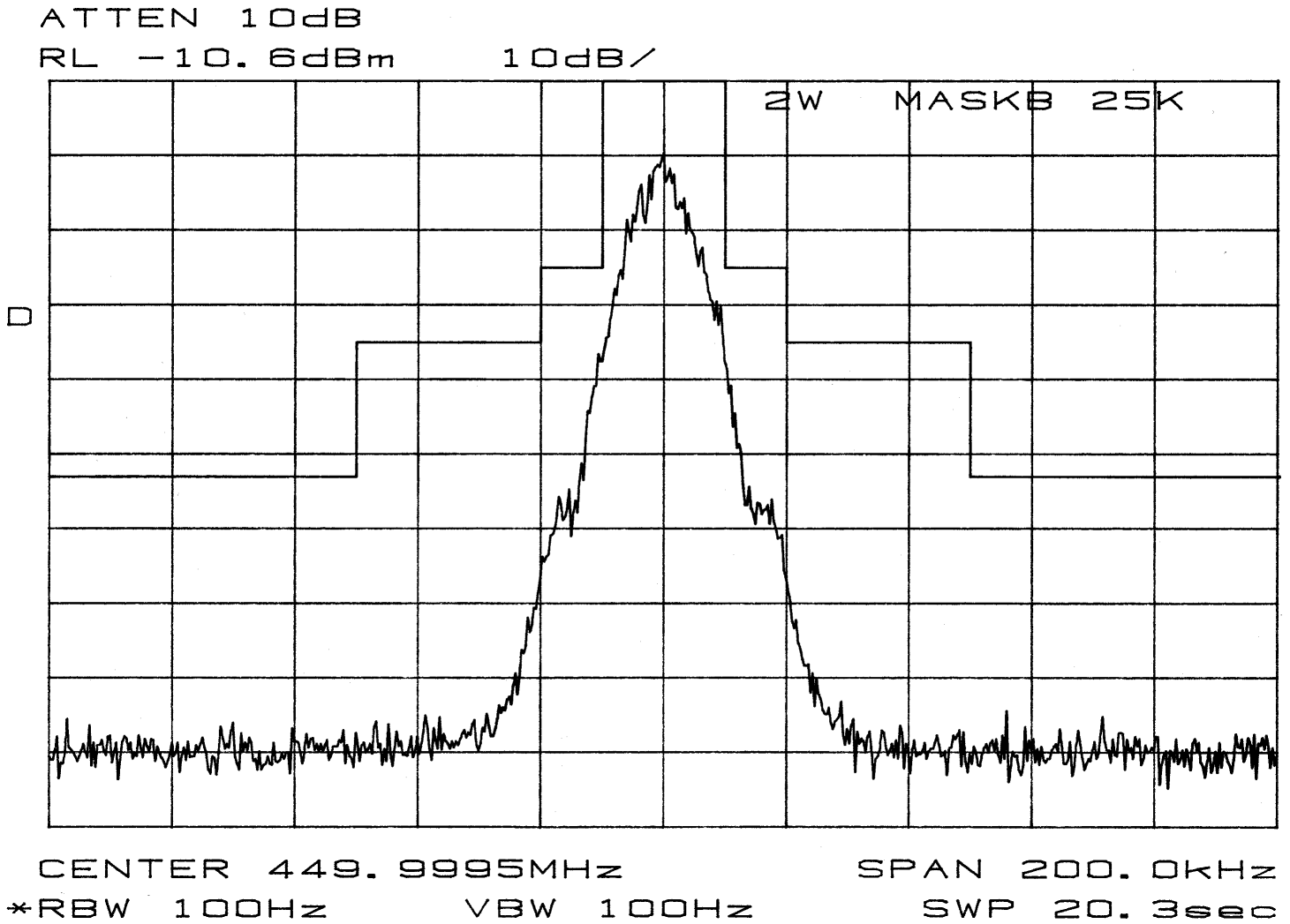

MASK: B
SPECTRUM FOR EMISSION 15K0F1D
OUTPUT POWER: 13 Watts
19200 bps
PEAK DEVIATION = 4000 Hz
SPAN = 200 kHz

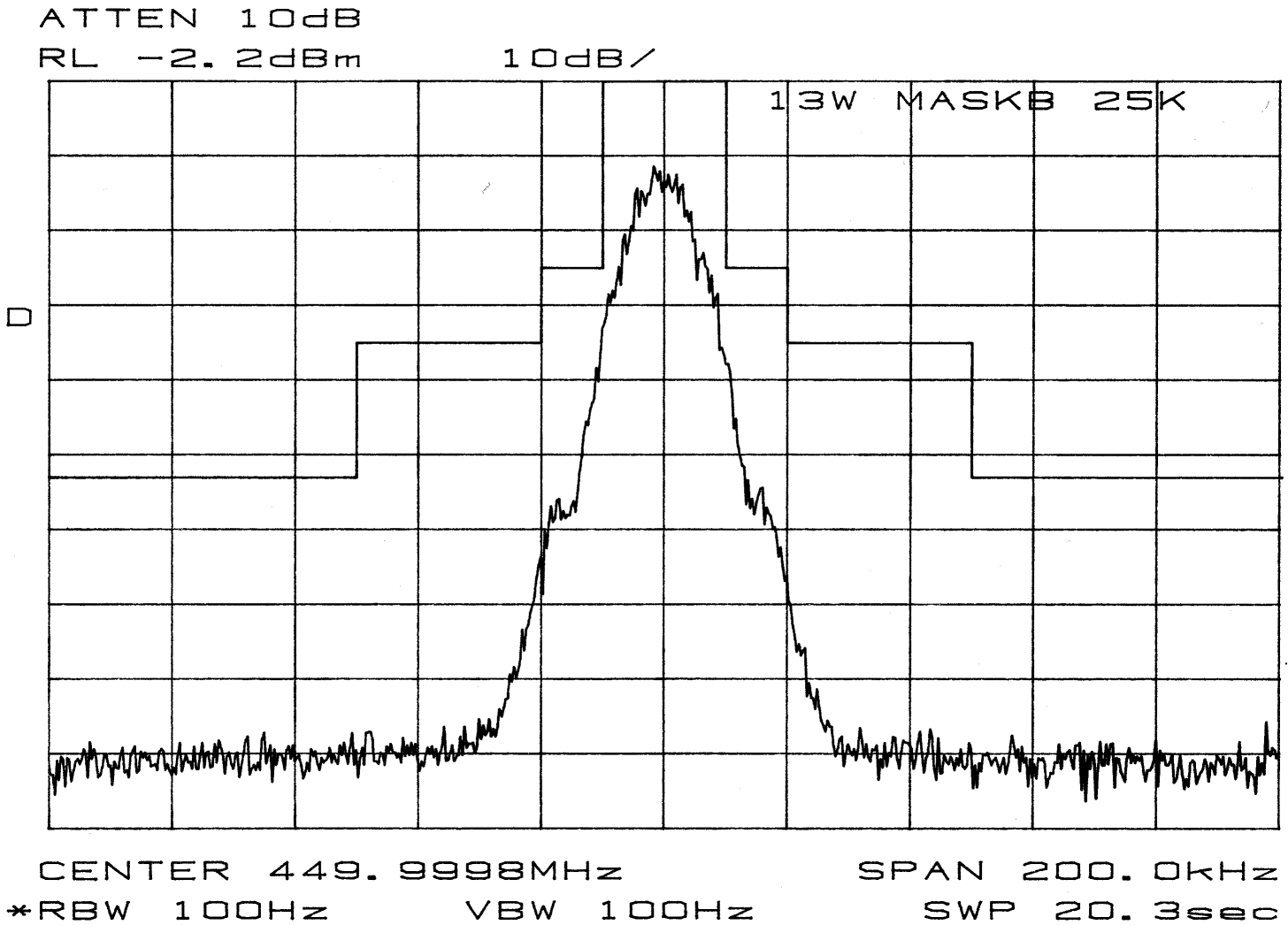

MASK: B
SPECTRUM FOR EMISSION 15K0F1D
OUTPUT POWER: 10 Watts
19200 bps
PEAK DEVIATION = 4000 Hz
SPAN = 200 kHz

ATTEN 10dB

RL -3.3dBm

10dB/

10W MASKB 25K

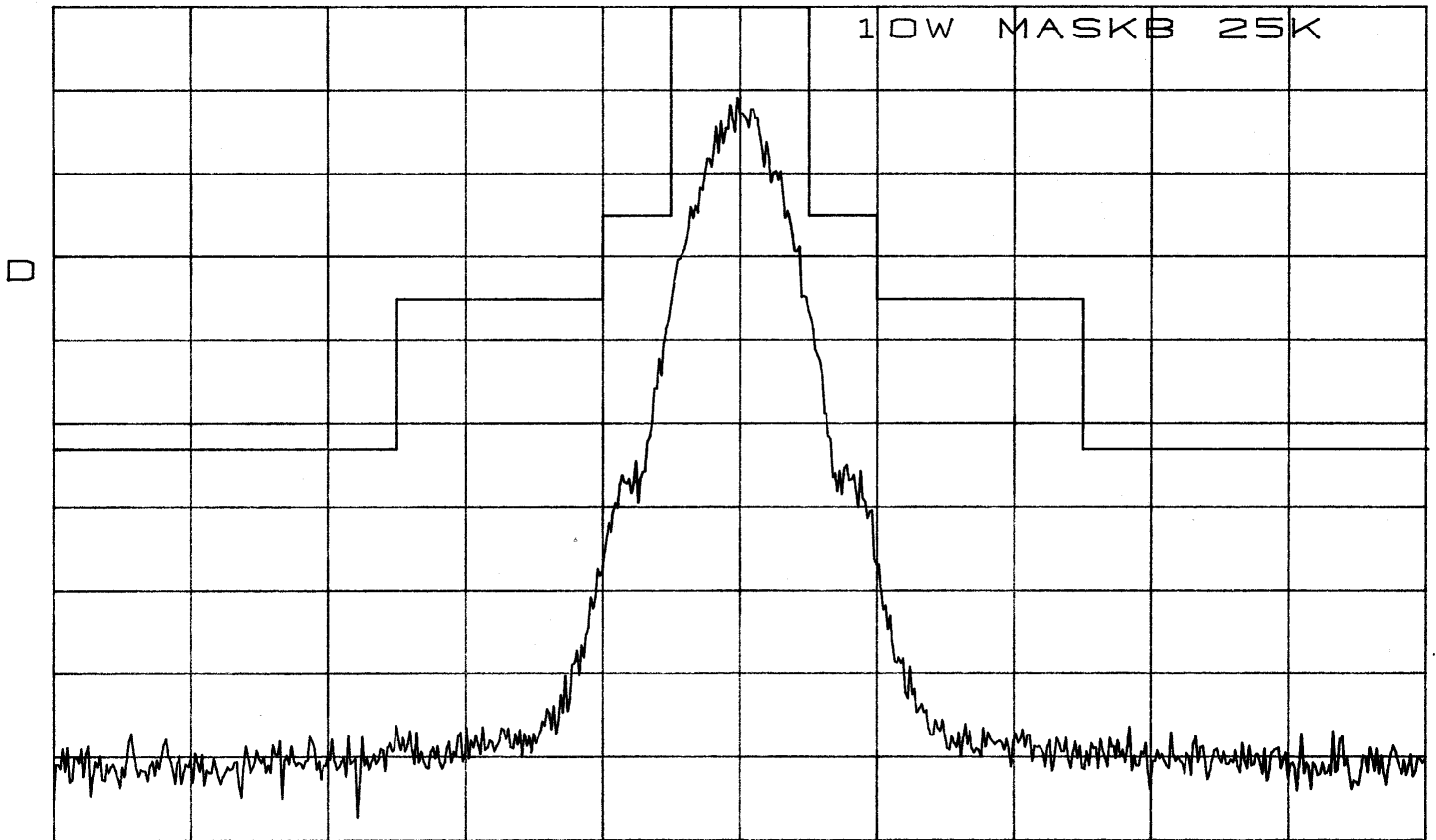

CENTER 449.9995MHz

SPAN 200.0kHz

*RBW 100Hz

VBW 100Hz

SWP 20.3sec

MASK: **B**
SPECTRUM FOR EMISSION **15K0F1D**
OUTPUT POWER: 50 Watts
19200 bps
PEAK DEVIATION = 4000 Hz
SPAN = 200 kHz

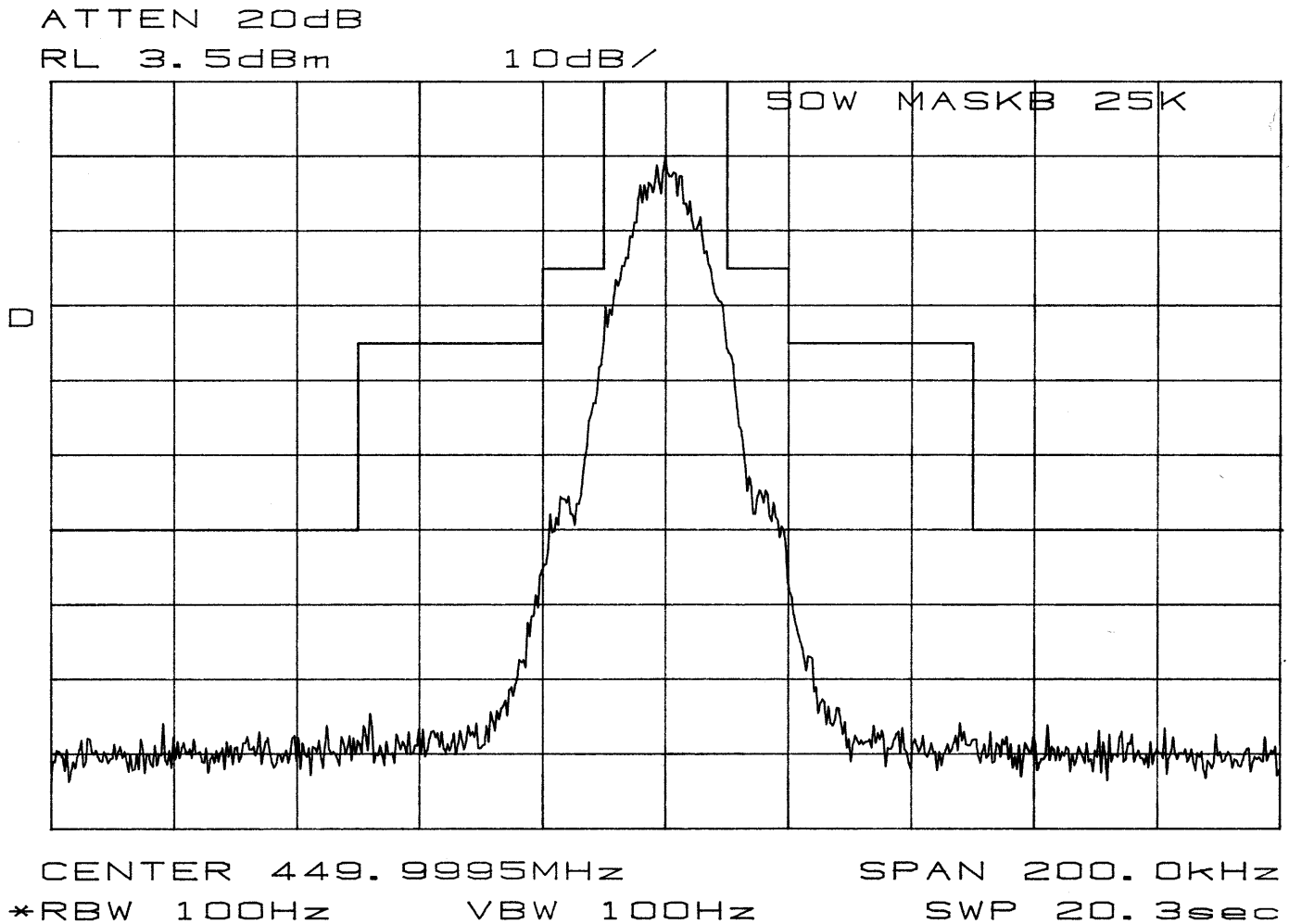

NAME OF TEST: Transmitter Spurious and Harmonic Outputs

RULE PART NUMBER: 2.1033 c (14), 2.1041, 2.1051, 90.210 (d)(3)

MINIMUM STANDARD: For 50 Watt: $50+10\text{Log}_{10}(50 \text{ Watts}) = 67 \text{ dBc}$
or 70 dBc whichever is the lesser attenuation.
For 10 Watt: $50+10\text{Log}_{10}(10 \text{ Watts}) = 60 \text{ dBc}$
or 70 dBc whichever is the lesser attenuation.

TEST RESULTS: Meets minimum standard (see data on the following page)

TEST CONDITIONS: Standard Test Conditions, 25 C
RF voltage measured at antenna terminals

TEST PROCEDURE: TIA/EIA - 603, 2.2.13

TEST EQUIPMENT: Attenuator, BIRD Model / 100-A-MFN-20 / 20 dB / 100 Watt
Attenuator, BIRD Model / 50-A-MFN-03 / 3 dB / 50 Watt
Digital Voltmeter, Fluke Model 8012A
DC Power Source, Model HP6024A
Spectrum Analyzer, Model HP8563E
Plotter, HP7470A
Reference Generator, Model HP83732B
Power Meter, Model HP436A
Audio Generator, Model HP8903B

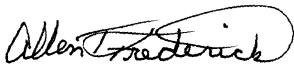
PERFORMED BY:  Date: 10/8/98
Allen Frederick

TEST SET-UP:

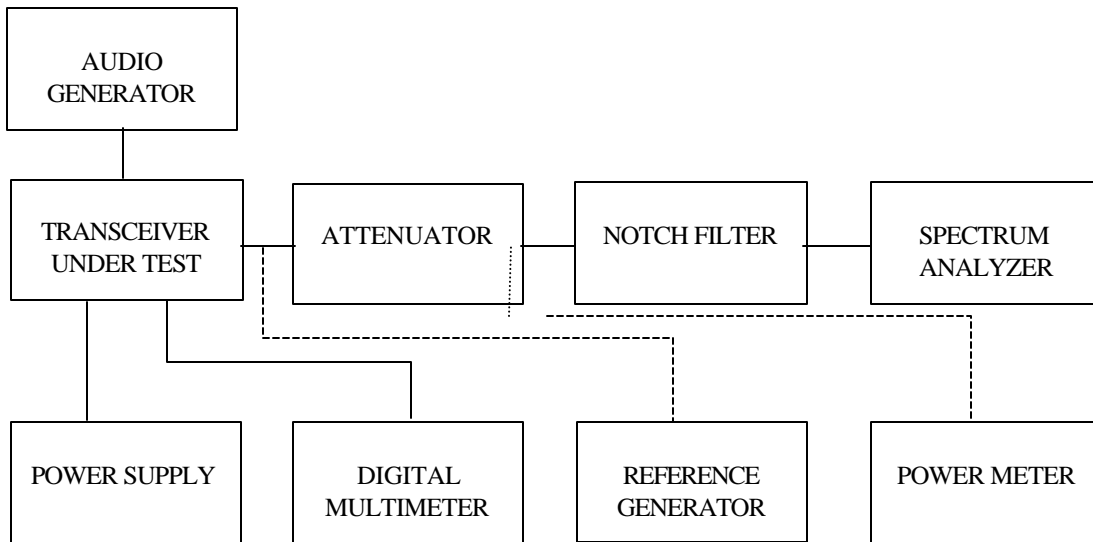

NAME OF TEST: Transmitter Spurious and Harmonic Outputs
(Continued)

MEASUREMENT PROCEDURE:

1. The transmitter carrier output frequency is 450.000 MHz. The reference oscillator frequency is 17.5000 MHz.
2. After carrier reference was established on spectrum analyzer, the notch filter was adjusted to null the carrier F_c to extend the range of the spectrum analyzer for harmonic measurements.
3. At each spurious frequency, Generator substitution was used to establish the true spurious level.
4. The spectrum was scanned to the 10th harmonic.

TEST DATA: See following four pages.

NAME OF TEST: Transmitter Spurious and Harmonic Outputs
(continued)

Power= **50 Watts**
46.99 dBm

Minimum Spec = **66.99 dBc**
Worse Case= 85.49 dBc

Spurious Frequency (MHz)	Substitution Generator (dBm)	dBc
190.883	-58.0	104.99
259.167	-55.5	102.49
359.458	-47.0	93.99
381.875	-52.0	98.99
409.075	-41.0	87.99
414.900	-54.5	101.49
418.050	-56.5	103.49
420.285	-47.0	93.99
420.408	-40.0	86.99
422.683	-40.0	86.99
422.850	-48.5	95.49
428.933	-52.0	98.99
432.517	-47.0	93.99
436.425	-51.0	97.99
463.600	-49.5	96.49
467.492	-46.5	93.49
471.142	-52.0	98.99
477.225	-45.5	92.49
477.367	-39.0	85.99
479.633	-39.5	86.49
479.867	-49.0	95.99
490.983	-41.0	87.99
504.567	-48.0	94.99
518.183	-46.0	92.99
520.317	-56.0	102.99
531.785	-50.5	97.49
900.000	-38.5	85.49
929.800	-48.0	94.99
1350.000	-50.0	96.99
1800.000	-50.5	97.49
2250.000	-43.5	90.49
2700.000	-43.0	89.99
3150.000	-57.0	103.99
3600.000	-58.0	104.99
4050.000	-58.0	104.99
4500.000	-48.5	95.49

*Bold face are harmonics of the Carrier

NAME OF TEST: Transmitter Spurious and Harmonic Outputs
(continued)

Power= 10 Watts
40.00 dBm

Minimum Spec = 60 dBc
Worse Case= 78.00 dBc

<u>Spurious Frequency (MHz)</u>	<u>Substitution Generator (dBm)</u>	<u>dBc</u>
68.180	-38.0	78.00
81.750	-45.5	85.50
190.867	-58.5	98.50
259.167	-54.0	94.00
381.892	-59.0	99.00
409.083	-54.5	94.50
418.067	-57.0	97.00
420.450	-49.5	89.50
422.683	-49.5	89.50
432.517	-49.5	89.50
436.417	-48.0	88.00
463.608	-55.0	95.00
467.500	-50.0	90.00
471.133	-53.0	93.00
477.217	-53.0	93.00
477.367	-41.0	81.00
479.583	-43.5	83.50
479.750	-50.0	90.00
482.000	-48.5	88.50
483.900	-52.5	92.50
485.183	-57.0	97.00
490.983	-44.5	84.50
504.567	-49.0	89.00
518.175	-43.0	83.00
520.325	-50.5	90.50
531.767	-50.0	90.00
900.000	-43.5	83.50
1350.000	-57.5	97.50
1800.000	-61.0	101.00
2250.000	-63.0	103.00
2700.000	-47.0	87.00
3150.000	-54.5	94.50
3600.000	-53.0	93.00
4050.000	-54.5	94.50
4500.000	-55.5	95.50

*Bold face are harmonics of the Carrier

NAME OF TEST: Transmitter Spurious and Harmonic Outputs
(continued)

Power= 13 Watts
41.14 dBm

Minimum Spec = 61.14 dBc
Worse Case= 74.14 dBc

<u>Spurious Frequency (MHz)</u>	<u>Substitution Generator (dBm)</u>	<u>dBc</u>
54.000	-50.0	91.14
190.000	-67.0	108.14
258.400	-66.0	107.14
394.860	-53.5	94.64
408.400	-44.0	85.14
422.660	-45.0	86.14
432.500	-54.0	95.14
436.430	-49.0	90.14
463.630	-46.0	87.14
467.500	-49.0	90.14
477.400	-42.0	83.14
490.700	-40.0	81.14
504.500	-45.0	86.14
518.200	-67.0	108.14
900.000	-40.0	81.14
1350.000	-33.0	74.14
1800.000	-56.0	97.14
2250.000	-35.5	76.64
2700.000	-64.0	105.14
3150.000	-58.0	99.14
3600.000	-70.0	111.14
4050.000	-74.0	115.14
4500.000	-63.5	104.64

*Bold face are harmonics of the Carrier

NAME OF TEST: Transmitter Spurious and Harmonic Outputs
(continued)

Power= 2 Watts
33.01 dBm

Minimum Spec = 53.01 dBc
Worse Case= 66.51 dBc

Spurious Frequency (MHz)	Substitution Generator (dBm)	dBc
54.550	-42.0	75.01
395.440	-43.5	76.51
409.070	-44.0	77.01
422.670	-52.0	85.01
432.540	-60.0	93.01
436.440	-58.0	91.01
463.650	-49.0	82.01
467.500	-47.5	80.51
477.370	-38.5	71.51
491.000	-39.0	72.01
504.550	-33.5	66.51
518.200	-53.0	86.01
900.000	-52.0	85.01
1350.000	-55.0	88.01
1800.000	-45.5	78.51
2250.000	-61.0	94.01
2700.000	-66.0	99.01
3150.000	-74.0	107.01
3600.000	-75.5	108.51
4050.000	-74.0	107.01
4500.000	-76.5	109.51

*Bold face are harmonics of the Carrier

NAME OF TEST: Field Strength of Spurious Radiation

RULE PART NUMBER: 2.1033 c (14), 2.1041, 2.1053, 90.210 (d)(3)

MINIMUM STANDARD: For 50 Watts: $50+10\text{Log}_{10}(50) = 67 \text{ dBc}$
For 10 Watts: $50+10\text{Log}_{10}(10) = 60 \text{ dBc}$
For 13 Watts: $50+10\text{Log}_{10}(13) = 61.14 \text{ dBc}$
For 2 Watts: $50+10\text{Log}_{10}(2) = 53 \text{ dBc}$

TEST RESULTS: Meets minimum standard (see data on the following page)

TEST CONDITIONS: Standard Test Conditions, 25 C

TEST PROCEDURE: TIA/EIA - 603, 2.2.12

TEST EQUIPMENT: Dipole Antenna Kit, Electro-Mechanics Model 3121C
Log Periodic Antenna, Model LPA-112
Reference Generator, Model HP83732A
Attenuator, BIRD Model / 100-A-MFN-20 / 20 dB / 100 Watt
Attenuator, BIRD Model / 50-A-MFN-03 / 3 dB / 50 Watt
Spectrum Analyzer, Model HP8563E
Power Meter, Model HP436A
Power Supply, Model HP-6024A

MEASUREMENT PROCEDURE: Radiated spurious attenuation was measured according to TIA/EIA Standard 603 Section 2.2.12

TEST SET-UP:

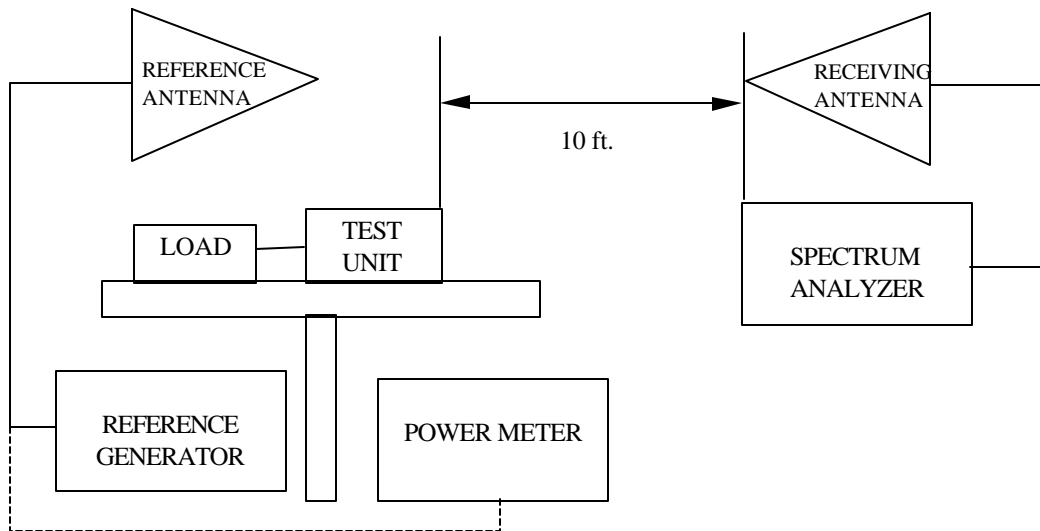

PERFORMED BY: Allen Frederick DATE: 10/8/98
Allen Frederick

NAME OF TEST: Spurious Radiation Attenuation
(Continued)

Frequency: 450 MHz
Power: 50 Watts
46.99 dBm

Spurious Frequency (MHz)	Polarization (Horz/Vert)	Spurious Level (dBm)	Substitution Generator (dBm)	Cable Loss (dB)	Antenna Gain (dBd)	Circular Polarization Correction (dB)	Spurious Attenuation dBc
900	H	-56.33	-20.00	5.50	-0.10	0.00	-72.59
	V	-60.67	-20.00	5.50	-0.10	0.00	-72.59
1350	H	-67.50	-20.50	6.33	1.20	3.00	-75.62
	V	-73.00	-25.50	6.33	1.20	3.00	-80.62
1800	H	-83.00	-39.00	7.00	1.20	3.00	-94.79
	V	-80.00	-37.00	7.00	1.20	3.00	-92.79
2250	H	-68.00	-22.50	8.33	1.20	3.00	-79.62
	V	-68.17	-21.50	8.33	1.20	3.00	-78.62
2700	H	-73.83	-27.50	9.17	1.20	3.00	-85.46
	V	-70.17	-24.00	9.17	1.20	3.00	-81.96
3150	H	-84.17	-36.50	10.17	1.20	3.00	-95.46
	V	-85.17	-36.50	10.17	1.20	3.00	-95.46
3600	H	-86.17	-38.00	11.67	1.20	3.00	-98.46
	V	-90.50	-41.00	11.67	1.20	3.00	-101.46
4050	H	-93.83	-39.00	12.50	1.20	3.00	-100.29
	V	-94.00	-38.00	12.50	1.20	3.00	-99.29
4500	H	-90.17	-40.00	12.67	1.20	3.00	-101.46
	V	-91.83	-39.50	12.67	1.20	3.00	-100.96

Frequency: 450 MHz
Power: 10 Watts
40.00 dBm

Spurious Frequency (MHz)	Polarization (Horz/Vert)	Spurious Level (dBm)	Substitution Generator (dBm)	Cable Loss (dB)	Antenna Gain (dBd)	Circular Polarization Correction (dB)	Spurious Attenuation dBc
900	H	-65.17	-29.00	5.50	-0.10	0.00	-74.60
	V	-67.33	-26.50	5.50	-0.10	0.00	-72.10
1350	H	-77.50	-31.00	6.33	1.20	3.00	-79.13
	V	-79.30	-32.00	6.33	1.20	3.00	-80.13
1800	H	-81.83	-37.50	7.00	1.20	3.00	-86.30
	V	-81.00	-37.50	7.00	1.20	3.00	-86.30
2250	H	-79.83	-34.00	8.33	1.20	3.00	-84.13
	V	-83.33	-36.00	8.33	1.20	3.00	-86.13
2700	H	-80.67	-34.00	9.17	1.20	3.00	-84.97
	V	-77.83	-31.00	9.17	1.20	3.00	-81.97
3150	H	-90.83	-43.00	10.17	1.20	3.00	-94.97
	V	-89.83	-41.00	10.17	1.20	3.00	-92.97
3600	H	-100.50	-52.00	11.67	1.20	3.00	-105.47
	V	-98.50	-49.00	11.67	1.20	3.00	-102.47
4050	H	-101.70	-46.00	12.50	1.20	3.00	-100.30
	V	-98.33	-42.50	12.50	1.20	3.00	-96.80
4500	H	-103.20	-53.00	12.67	1.20	3.00	-107.47
	V	-107.30	-55.00	12.67	1.20	3.00	-109.47

NAME OF TEST: Spurious Radiation Attenuation
(Continued)

Frequency: 450 MHz Min Spec 61.14 dBc
Power: 13 Watts
41.1 dBm

Spurious Frequency (MHz)	Polarization (Horz/Vert)	Spurious Level (dBm)	Substitution Generator (dBm)	Cable Loss (dB)	Antenna Gain (dBd)	Circular Polarization Correction (dB)	Spurious Attenuation dBc
900	H	-56.00	-20.00	5.50	-0.10	0.00	-66.70
	V	-57.67	-20.00	5.50	-0.10	0.00	-66.70
1350	H	-77.17	-34.50	6.33	1.20	3.00	-83.73
	V	-74.50	-32.83	6.33	1.20	3.00	-82.06
1800	H	-85.33	-40.50	7.00	1.20	3.00	-90.40
	V	-81.83	-36.00	7.00	1.20	3.00	-85.90
2250	H	-78.67	-30.50	8.33	1.20	3.00	-81.73
	V	-74.50	-24.83	8.33	1.20	3.00	-76.06
2700	H	-73.33	-22.00	9.17	1.20	3.00	-74.07
	V	-67.50	-15.17	9.17	1.20	3.00	-67.24
3150	H	-76.67	-23.00	10.17	1.20	3.00	-76.07
	V	-73.50	-19.50	10.17	1.20	3.00	-72.57
3600	H	-88.67	-30.50	11.67	1.20	3.00	-85.07
	V	-87.00	-30.00	11.67	1.20	3.00	-84.57
4050	H	-96.00	-36.50	12.50	1.20	3.00	-91.90
	V	-91.00	-30.67	12.50	1.20	3.00	-86.07
4500	H	-91.50	-30.50	12.67	1.20	3.00	-86.07
	V	-86.67	-26.00	12.67	1.20	3.00	-81.57

Frequency: 450 MHz Min Spec 53.01 dBc
Power: 2 Watts
33.0 dBm

Spurious Frequency (MHz)	Polarization (Horz/Vert)	Spurious Level (dBm)	Substitution Generator (dBm)	Cable Loss (dB)	Antenna Gain (dBd)	Circular Polarization Correction (dB)	Spurious Attenuation dBc
900	H	-75.67	-40.00	5.50	-0.10	0.00	-78.60
	V	-74.00	-37.00	5.50	-0.10	0.00	-75.60
1350	H	-77.33	-34.50	6.33	1.20	3.00	-75.63
	V	-78.67	-37.00	6.33	1.20	3.00	-78.13
1800	H	-85.83	-40.00	7.00	1.20	3.00	-81.80
	V	-84.67	-38.84	7.00	1.20	3.00	-80.64
2250	H	-86.83	-38.00	8.33	1.20	3.00	-81.13
	V	-87.67	-38.00	8.33	1.20	3.00	-81.13
2700	H	-80.67	-29.50	9.17	1.20	3.00	-73.47
	V	-81.17	-28.84	9.17	1.20	3.00	-72.81
3150	H	-89.00	-36.00	10.17	1.20	3.00	-80.97
	V	-85.33	-31.33	10.17	1.20	3.00	-76.30
3600	H	-102.00	-46.00	11.67	1.20	3.00	-92.47
	V	-100.20	-43.20	11.67	1.20	3.00	-89.67
4050	H	-102.00	-42.50	12.50	1.20	3.00	-89.80
	V	-103.00	-42.67	12.50	1.20	3.00	-89.97
4500	H	-99.80	-38.50	12.67	1.20	3.00	-85.97
	V	-98.50	-37.83	12.67	1.20	3.00	-85.30

CALCULATIONS FOR FIELD STRENGTH OF SPURIOUS RADIATION TESTS:

The transmitter carrier frequency was set to 450.000 MHz. The reference oscillator frequency of all of the transceivers is 17.50 MHz. The output of the transceivers was searched from 17.50 MHz to the tenth harmonic of the carrier frequencies. The tests were conducted with the transceiver/modem/GPS inside of the enclosure.

Because the antennas used for the measurements recorded above 1 GHz were not flat in gain and differed from a dipole, the generator output was corrected for gain at each spurious frequency. The cable loss in the measurements is the loss in the cable between the signal generator and the substitution antenna. An additional 3 dB correction was also made to the spurious responses measured above 1 GHz to correct for the 3 dB polarization loss in the reference path.

EXAMPLE:

At 900 MHz (450 MHz tuned), 50 Watts and horizontal polarization.

r = Substitution Gen - Cable Loss	-20.0 - 5.5	= -25.5
R = Reference Generator (dBm)	-25.5	
A = Antenna Gain (dB)	-.10	
P = Polarization Correction Factor (dB)	0.0	
R' (Corrected Reference (dBm)) = R + A - P =>	-25.5 + -.1 - 0.0	= -25.60 dBm
Po = Radiated Carrier Power (dBm)	50 Watts = 46.99 dBm	
Radiated Spurious Emission (dBc) = Po - R' =>	-25.60 - (+46.99)	= -72.59 dBc

NAME OF TEST: Frequency Stability with Variation in Ambient Temperature
RULE PART NUMBER: 2.1033 c (14), 2.1041, 2.1055(a), 90.213 (a)
MINIMUM STANDARD: Shall not exceed $\pm 0.000150\%$ from test frequency, or 1.50 ppm
TEST RESULTS: Meets minimum standard, see data on following page
TEST CONDITIONS: Standard Test Conditions, 25 C
TEST EQUIPMENT: Attenuator, BIRD Model / 100-A-MFN-20 / 20 dB / 100 Watt
Attenuator, BIRD Model / 50-A-MFN-03 / 3 dB / 50 Watt
Frequency Counter, HP 5383A
Digital Voltmeter, Model HP6656A
DC Power Source, Model HP6656A
Climate Chamber, TempGard III, Tenney Jr.



PERFORMED BY: _____ DATE: 9/15/98
Mike Dickinson

TEST SET-UP:

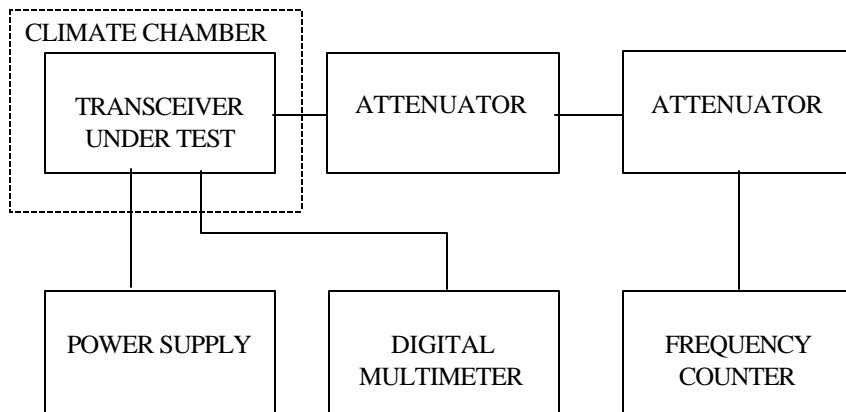

(Test data on next page)

NAME OF TEST: Frequency Stability with Variation in Ambient Temperature
(Continued)

Frequency Reference: 450000000 Hz
Tolerance Requirement: 1.5 ppm
Highest Variation (ppm): 0.360 ppm

450	Frequency (MHz)	Freq. Delta (Hz)	ppm from assigned frequency
-30	449.999838	-162	-0.360
-20	450.000009	9	0.020
-10	450.000060	60	0.133
0	450.000072	72	0.160
10	450.000128	128	0.284
20	450.000135	135	0.300
30	450.000128	128	0.284
40	450.000080	80	0.178
50	449.999961	-39	-0.087
60	449.999848	-152	-0.338

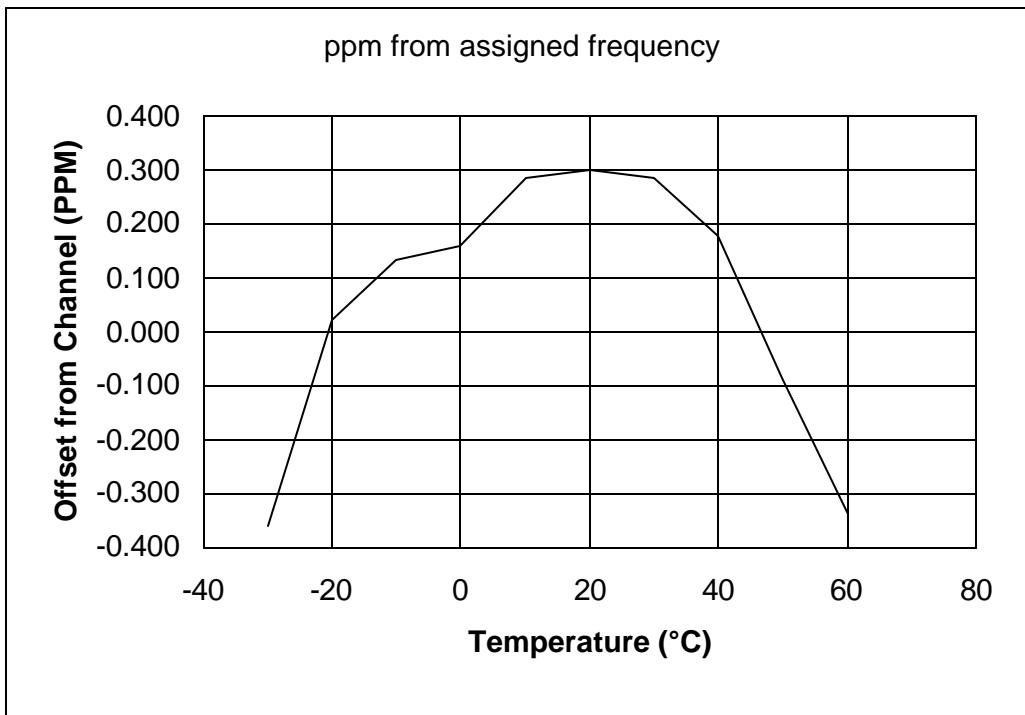

NAME OF TEST: Frequency Stability with Variation in Supply Voltage

RULE PART NUMBER: 2.1033 c (14), 2.1041, 2.1055(d), 90.213 (a)

MINIMUM STANDARD: Shall not exceed $\pm 0.000150\%$ from test frequency, 1.50 ppm for $\pm 15\%$ change in supply voltage

TEST RESULTS: Meets minimum standard, see data on following page

TEST CONDITIONS: Standard Test Conditions, 25 C

TEST EQUIPMENT: Attenuator, BIRD Model / 100-A-MFN-20 / 20 dB / 100 Watt
Attenuator, BIRD Model / 50-A-MFN-03 / 3 dB / 50 Watt
Frequency Counter, HP 5383A
Digital Voltmeter, Model HP6656A
DC Power Source, Model HP6656A



PERFORMED BY: _____ DATE: 9/15/98
Mike Dickinson

TEST SET-UP:

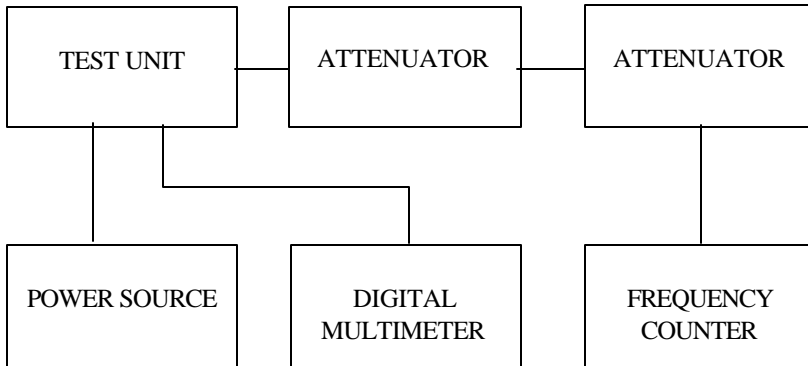

(Test data on next page)

NAME OF TEST: Frequency Stability with Variation in Supply Voltage
(Continued)

MEASUREMENTS TAKEN:

1.5 ppm Reference Oscillator

Frequency Reference: 450 MHz
Tolerance Requirement: 0.00015 %
Tolerance Requirement: 1.5 ppm
Highest Variation (ppm): 0.291 ppm

450	Frequency (MHz)	Freq. Delta % of assigned frequency)	Spec Limit (% of assigned frequency)	ppm from assigned frequency
10	450.000131	0.00003	0.00015	0.291
13	450.000130	0.00003	0.00015	0.289
16	450.000126	0.00003	0.00015	0.280

NAME OF TEST: Transient Frequency Behavior

RULE PART NUMBER: 90.214

TEST CONDITIONS: The transient test was performed with the transmitter transmitting just a carrier tone. Also supplied is a transient test which was conducted with the Gemini modem modulating the transmitter with 2400 Hz tone.

MINIMUM STANDARD: **12.5 kHz channel** (used worst case numbers from 403 to 512 MHz)
25 kHz channel (used worst case numbers from 403 to 512 MHz)

NOTE: Following plots were done using method TIA/EIA 603, 2.2.19. All plots show signal generator reference of +/- 12.5KHz so 25KHz channel minimum standard is also met since 12.5KHz minimum standard is the more strict standard.

TIME INTERVAL	MAX FREQ DIFFERENCE (kHz)	MAX FREQ DIFFERENCE (kHz)	TIME (ms)
	12.5KHz CH	25 kHz CH	
T1	+/- 12.5	+/- 25	10
T2	+/- 6.25	+/- 12.5	25
T3	+/- 12.5	+/- 25	10

TEST RESULTS: Meets minimum standards, see data on following pages

TEST CONDITIONS: RF Power Level = 2,13,10,50 Watts (see following plots)
Standard Test Conditions, 25 C

TEST PROCEDURE: TIA/EIA - 603, 2.2.19

TEST EQUIPMENT: Attenuator, BIRD Model / 100-A-MFN-20 / 20 dB / 100 Watt
Attenuator, BIRD Model / 50-A-MFN-03 / 3 dB / 50 Watt
Digital Voltmeter, Fluke Model 8012A
DC Power Source, Model HP6024A
Modulation Analyzer, Model HP8901A
RF Detector (Spectrum Analyzer), Model HP8563E
Plotter, Model HP2671G
Reference Generator, Fluke Model 6071A
Power Meter, Model HP436A
Power Combiner, Model MCL ZFSC-4-1
Oscilloscope, Model HP54503A
Directional Coupler, Model HP778D



PERFORMED BY:

Allen Frederick

Date: 10/2/98

NAME OF TEST: Transient Frequency Behavior (Continued)

TEST SET-UP:

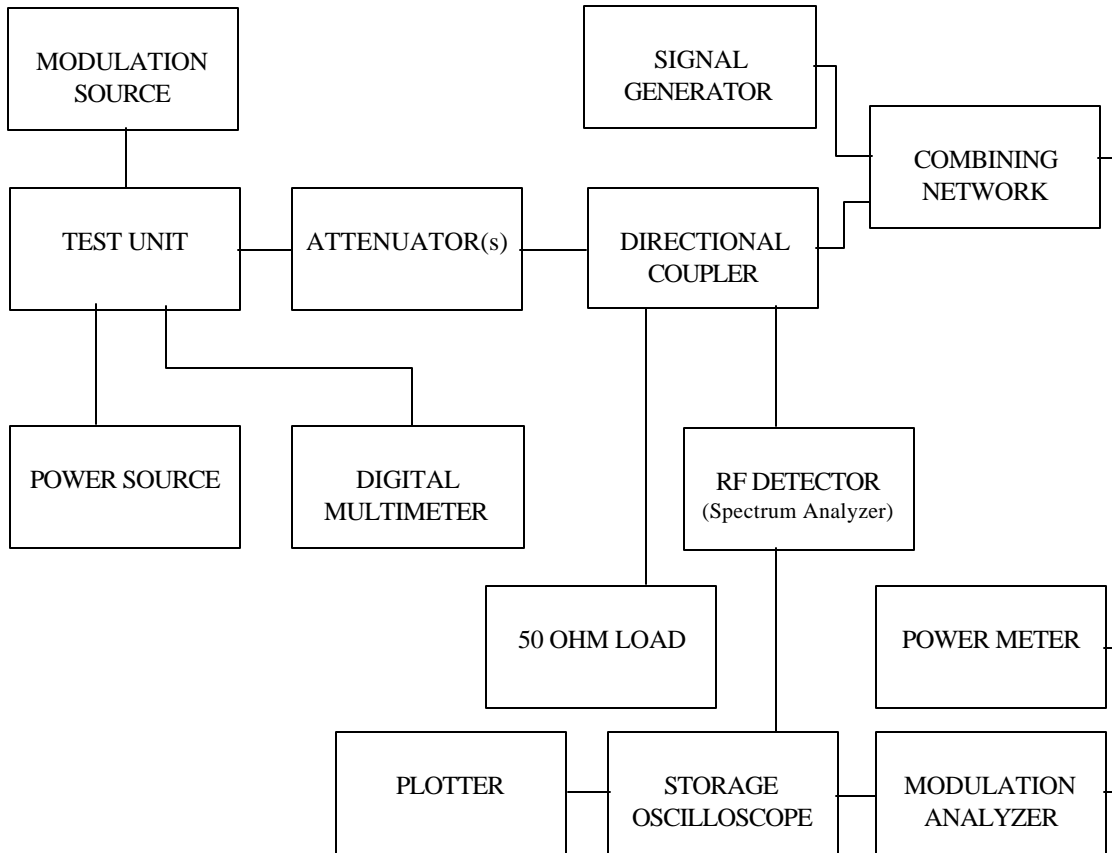

TRANSIENT FREQUENCY RESPONSE
Transceiver Unmodulated 10 Watts

KEY UP

hp awaiting trigger

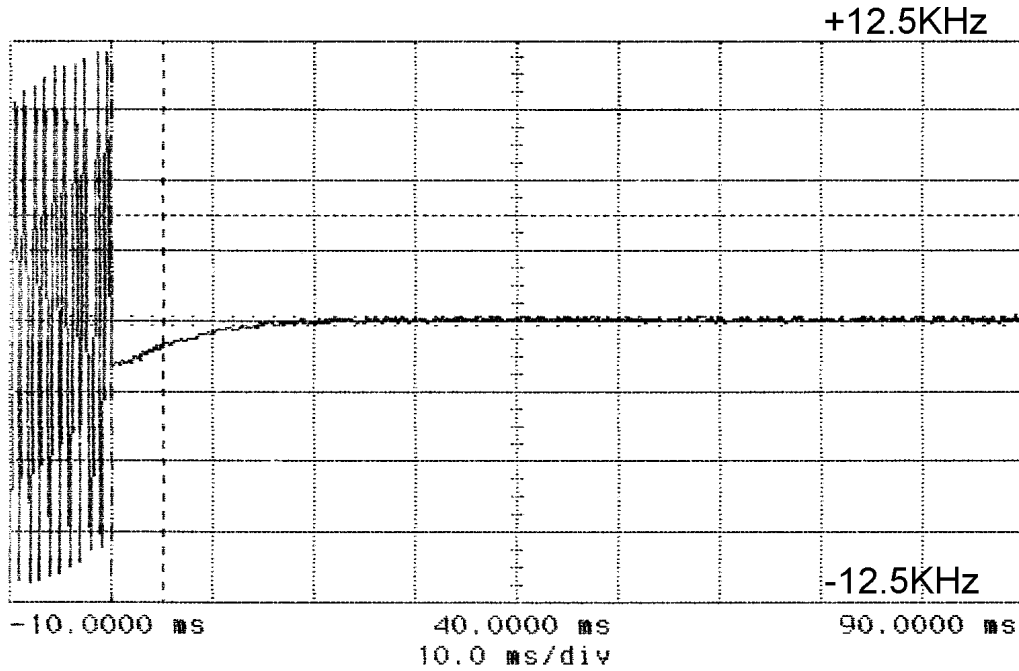

KEY DOWN

hp awaiting trigger

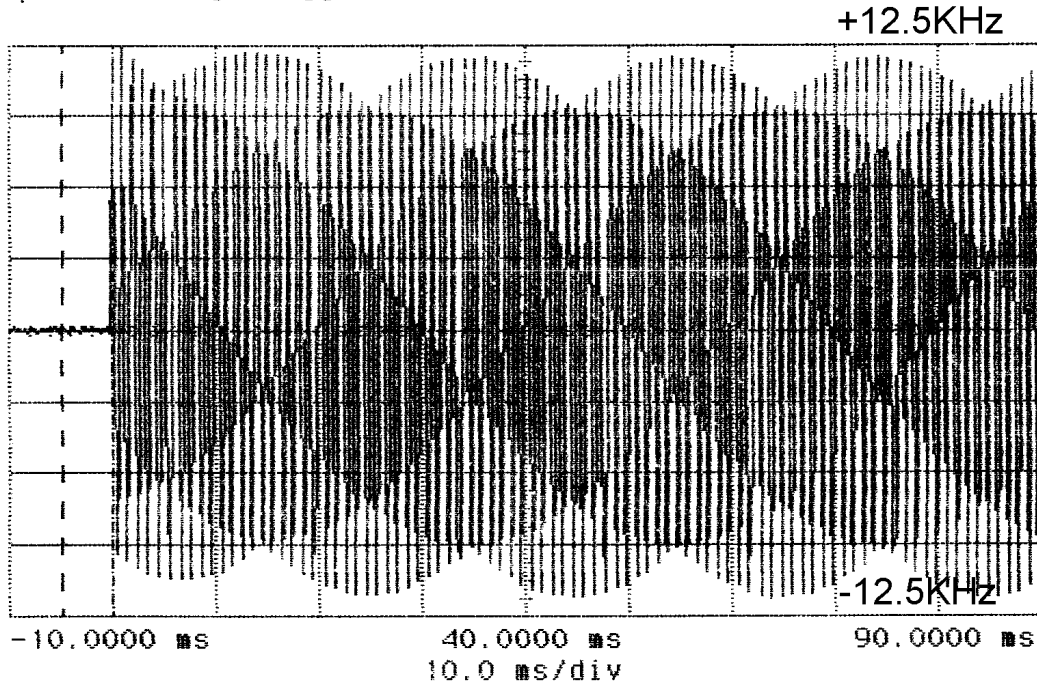

TRANSIENT FREQUENCY RESPONSE
Transceiver Modulated with 2400 Hz Tone: 10 Watts

KEY UP

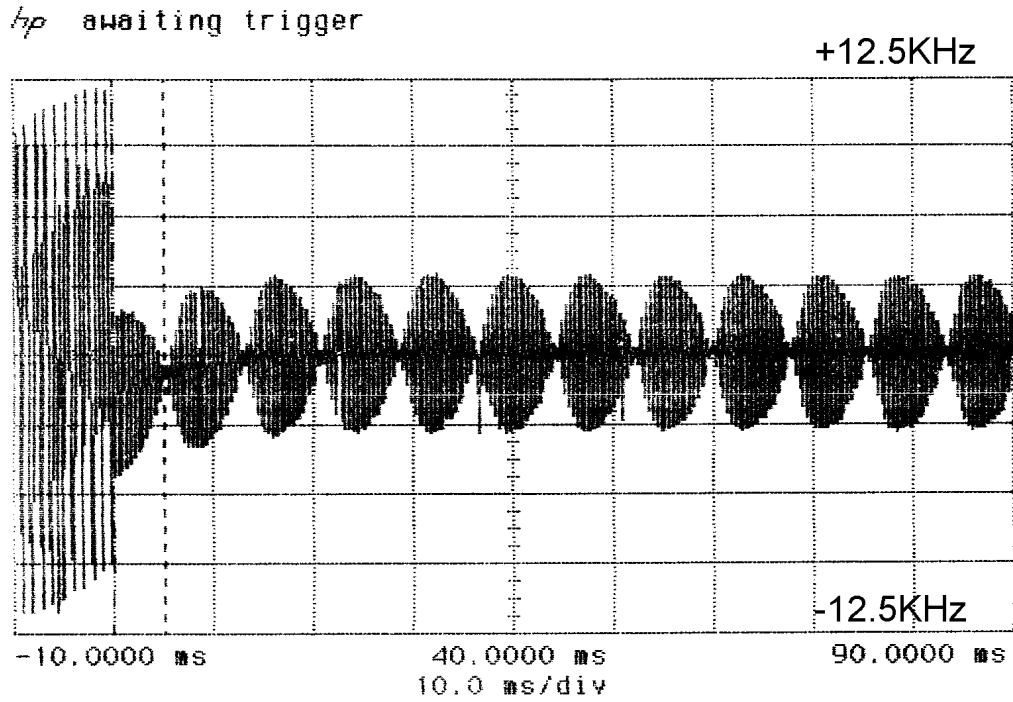

KEY DOWN

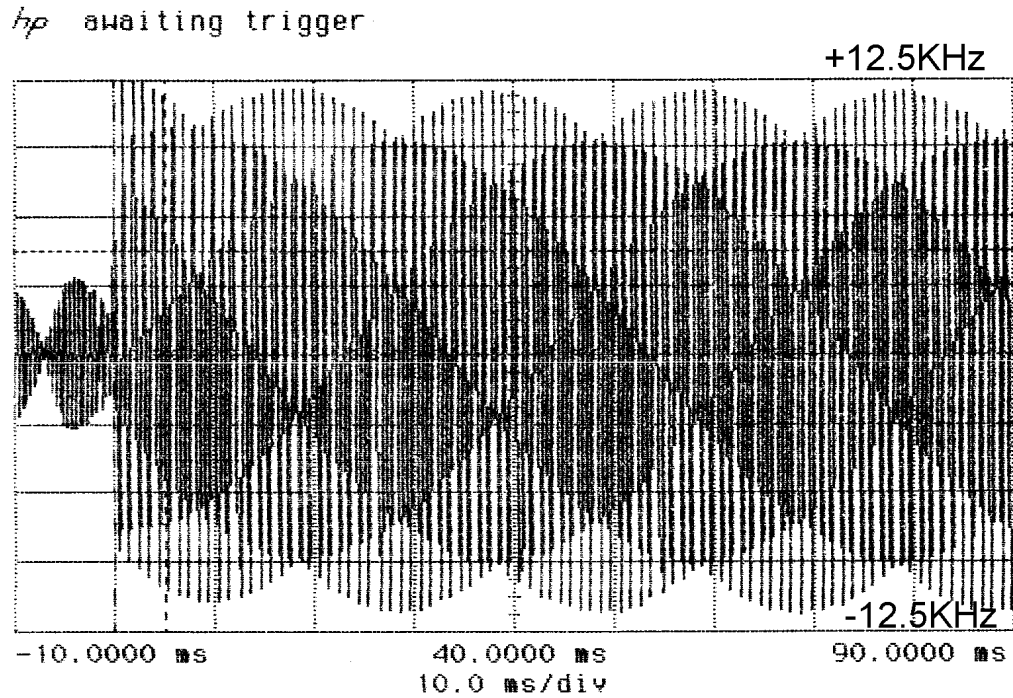

TRANSIENT FREQUENCY RESPONSE
Transceiver Unmodulated 50 Watts

KEY UP

hp awaiting trigger

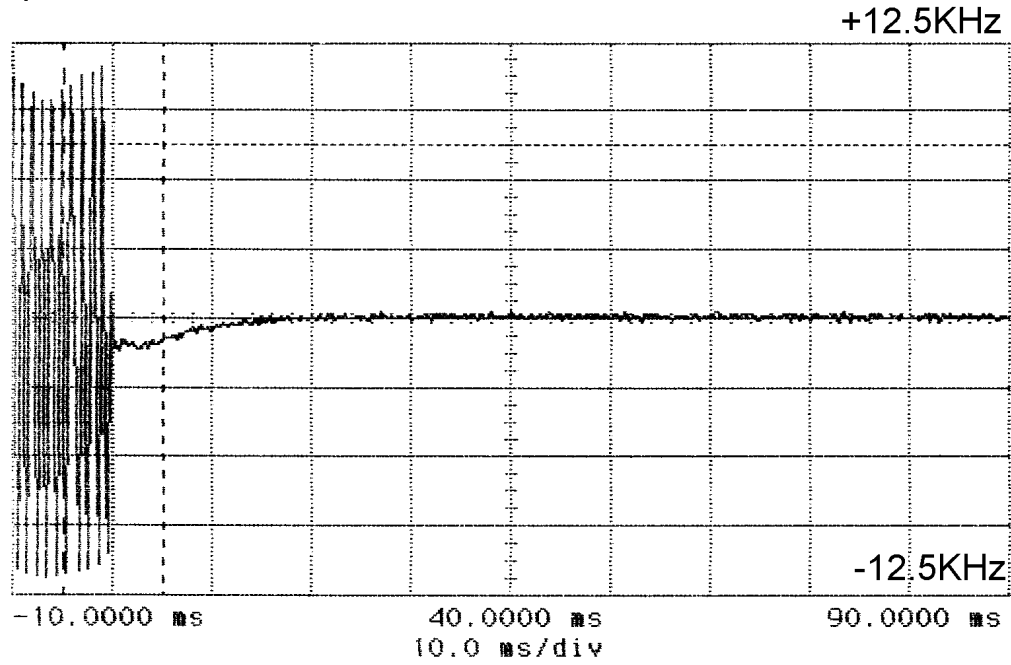

KEY DOWN

hp awaiting trigger

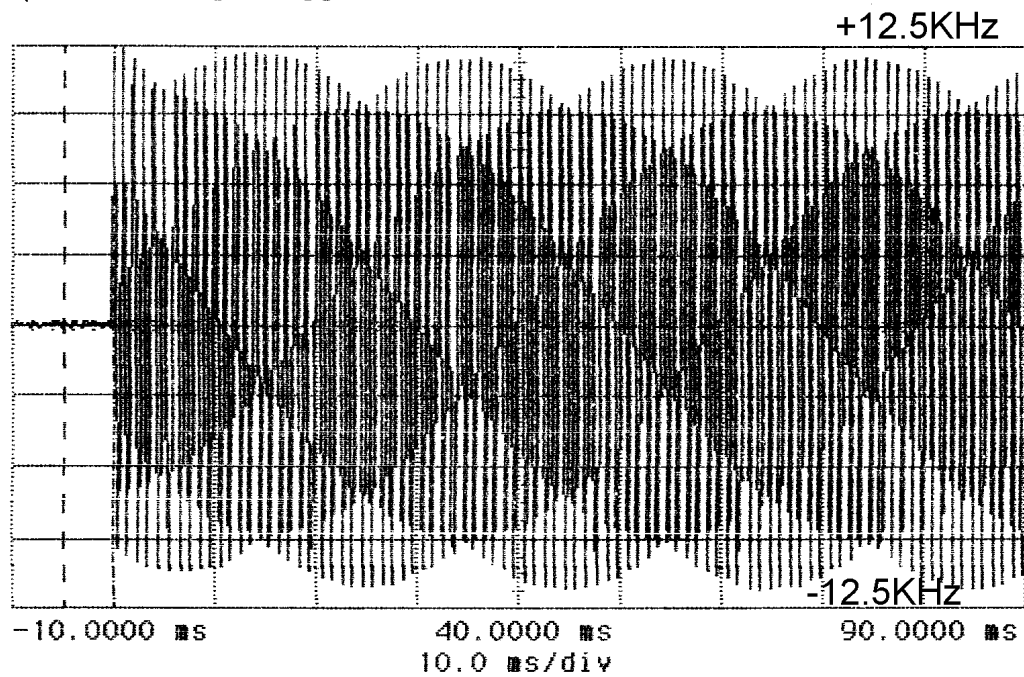

TRANSIENT FREQUENCY RESPONSE
Transceiver Modulated with 2400 Hz Tone: 50 Watts

KEY UP

hp awaiting trigger

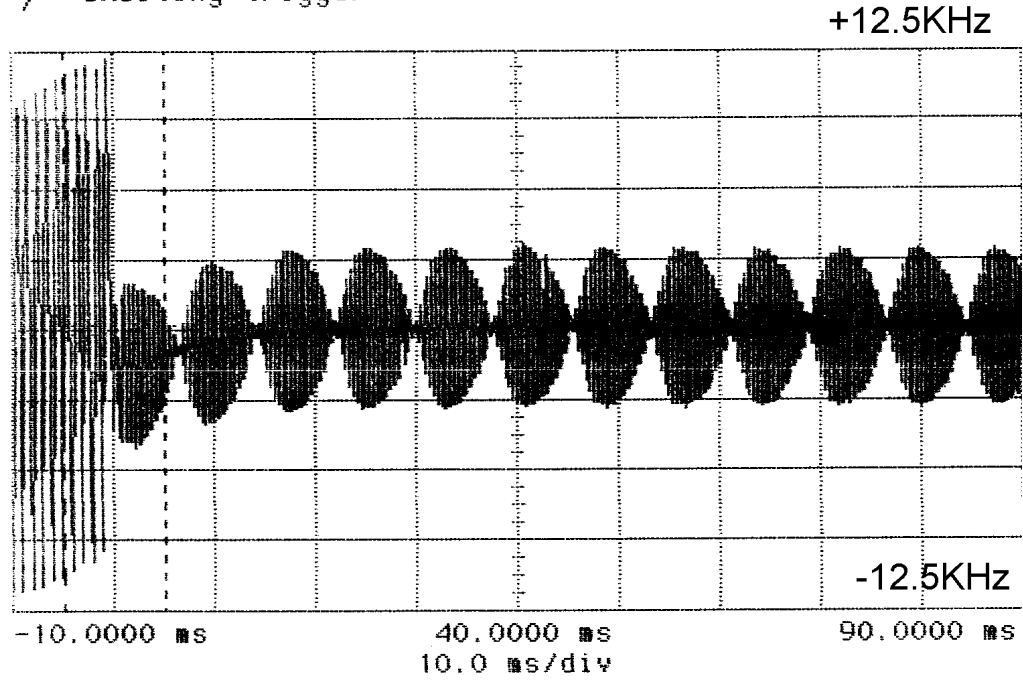

KEY DOWN

hp awaiting trigger

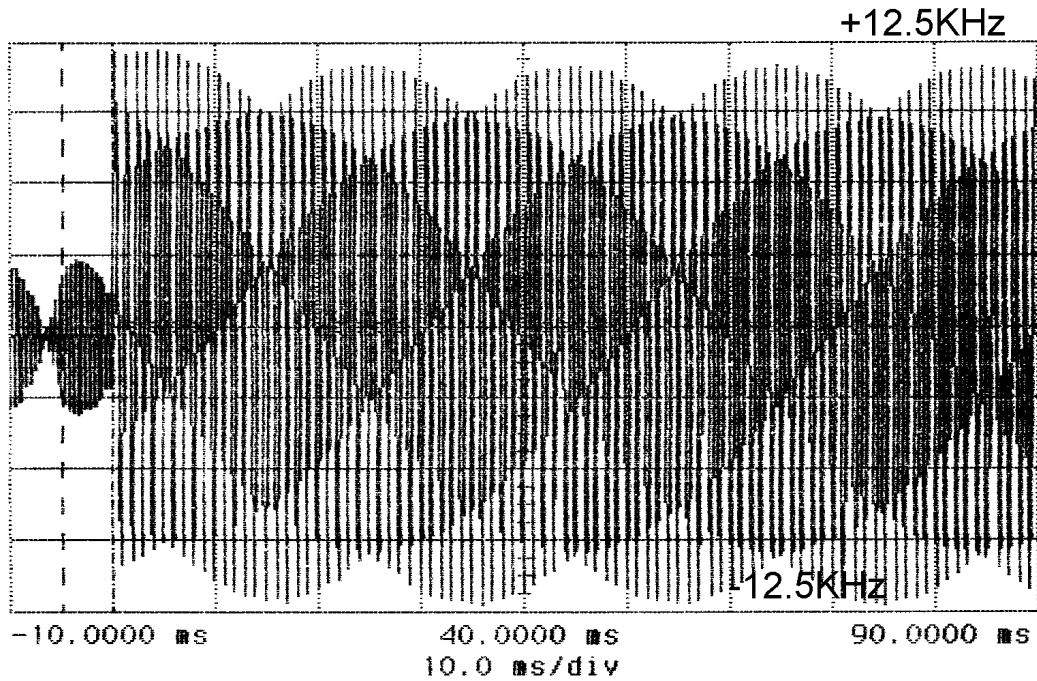

TRANSIENT FREQUENCY RESPONSE
Transceiver Unmodulated 2 Watts

KEY UP

hp awaiting trigger

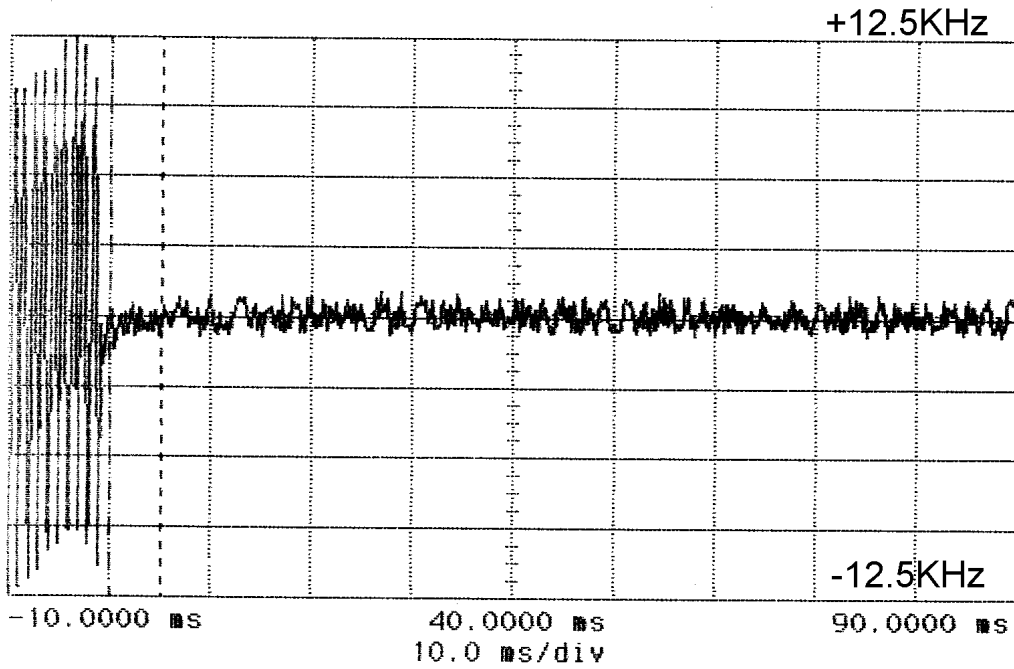

KEY DOWN

hp awaiting trigger

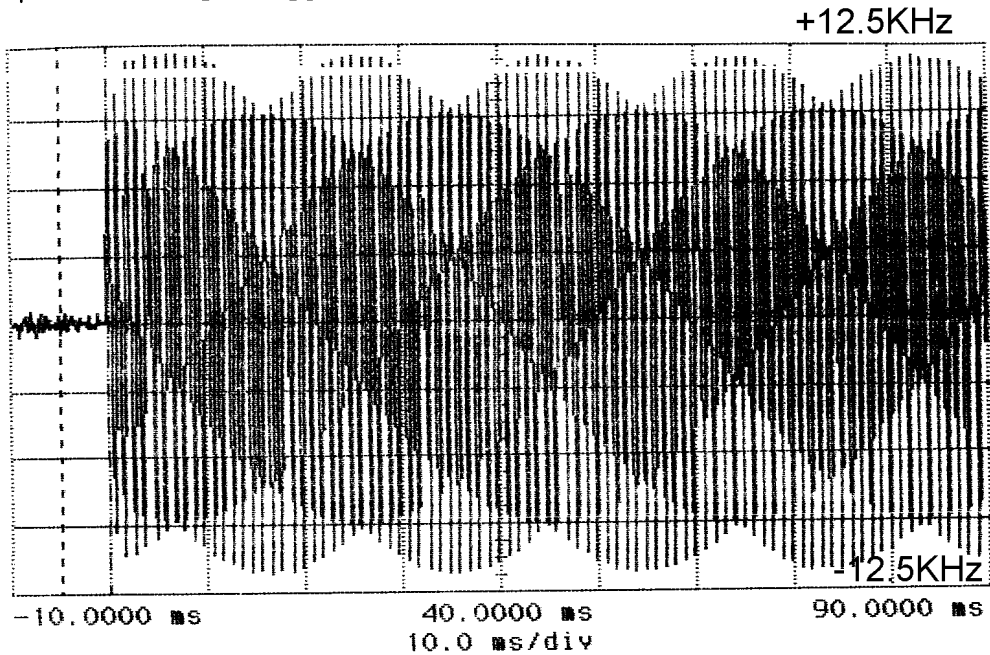

TRANSIENT FREQUENCY RESPONSE
Transceiver Unmodulated 13 Watts

KEY UP

hp awaiting trigger

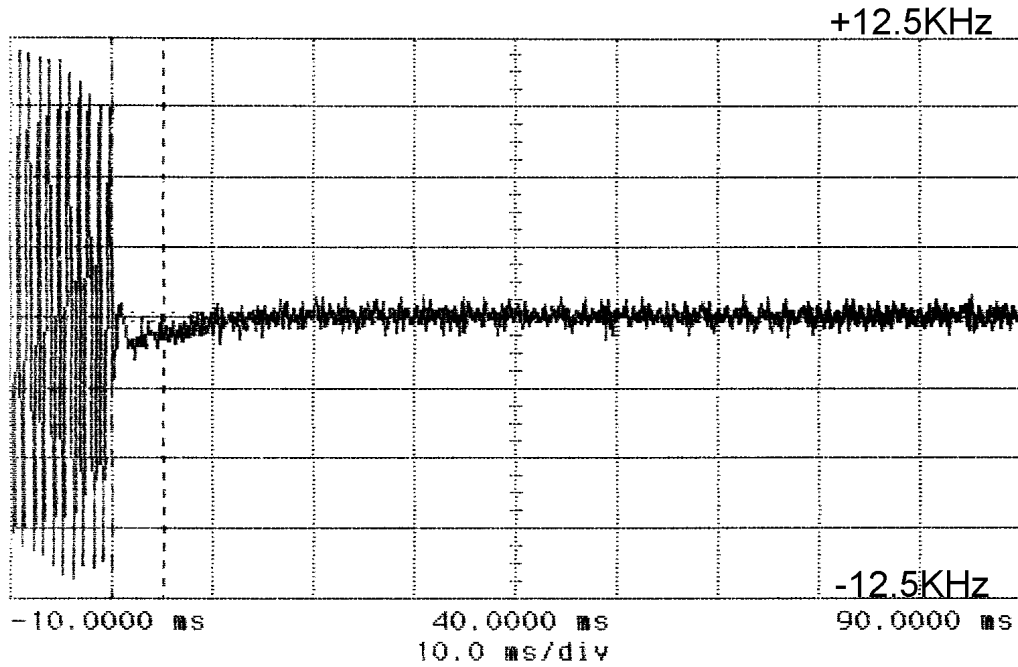

KEY DOWN

hp awaiting trigger

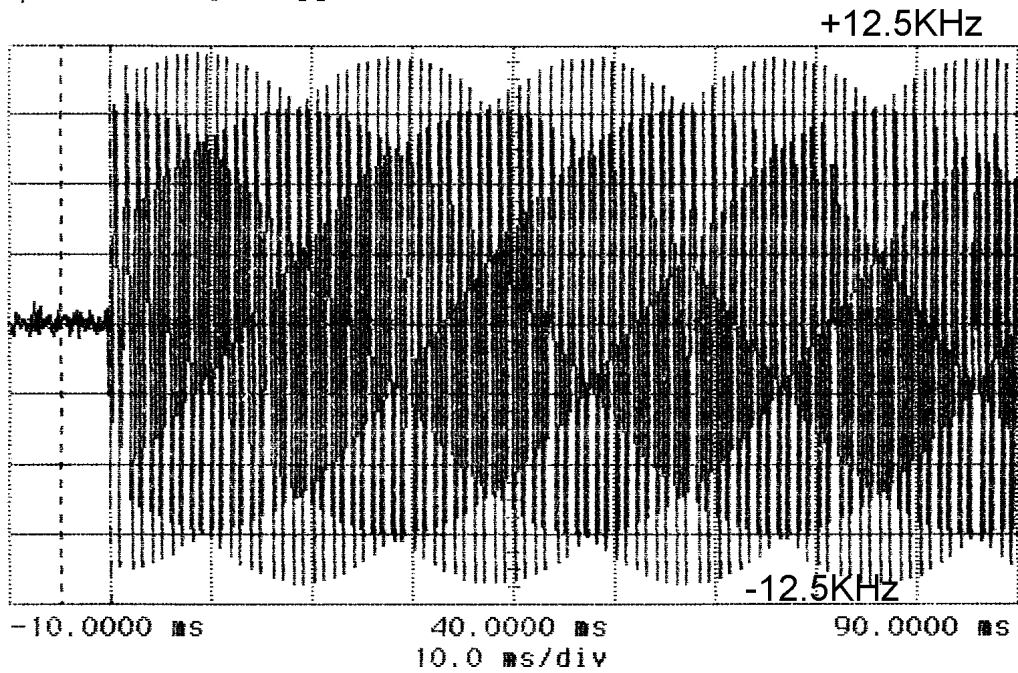

FCC LABEL:

RULE PART NUMBER: 2.1033 c (11)

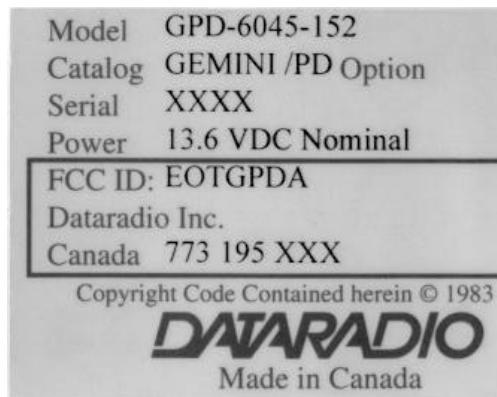

PHOTOGRAPHS:

RULE PART NUMBER: 2.1033 c (12)
Presented as annexed file.