

Production procedure			<i>DATARADIO Inc.</i>		Page 1 of 12
Authors: Michel Martin Nicolas Savard	Validated: M. Martin	Approved:	Procedure: 164-20006-031	Rev. date: 2000-07-24	Rev: 1.0
Radio Interface Bulletin					
Tait UHF Base Series II (diversity)					

Radio: UHF T800 Tait Series II Base Station (400-520MHz).

Interface type: DBA (DSP based on D212A PCB)

Product: Paragon PD

Channel Type : Half & full Channels

Note: This procedure includes the EEPROM module implementation into the receiver & exciter

1 PART LIST.....	1
2 MECHANICAL & ELECTRICAL INTERFACE.....	2
2.1 T857 EXCITER MODULE MODIFICATIONS REVISION 220-01398-03A.....	2
2.2 T857 EXCITER MODULE MODIFICATIONS REVISION 220-01398-04.....	3
2.2 T855 RECEIVER MODULE MODIFICATIONS.....	4
FIGURE 1- T857 EXCITER PCB (REV 220-01398-(03A & 04)), TOP SIDE (EEPROM MODULE) 1/2	5
FIGURE 2- T857 EXCITER PCB (REV 220-01398-(03A & 04)), BOTTOM SIDE (EEPROM MODULE) 2/2	5
FIGURE 3 - T857 EXCITER PCB (REV 220-01398-03A), TOP SIDE 1/1.....	6
FIGURE 4 - T857 EXCITER PCB (REV 220-01398-04),TOP SIDE 1/2.....	7
FIGURE 5 - T857 EXCITER PCB (REV 220-01398-(03A & 04), BOTTOM SIDE (FAST TXKEY SETTING) 2/2	7
FIGURE 6 - 855 RECEIVER PCB, TOP SIDE (EEPROM MODULE) 1/4.....	8
FIGURE 7 - 855 RECEIVER PCB, BOTTOM SIDE (EEPROM MODULE) 2/4	8
FIGURE 8 - T855 RECEIVER PCB, BOTTOM SIDE 3/4	9
FIGURE 9 - T855 RECEIVER PCB, TOP SIDE 4/4.....	9
FIGURE 10 – TYPICAL RADIO AND POWER SUPPLIES ASSEMBLY FRONT VIEW 1/2	10
FIGURE 11 - TYPICAL RADIO AND POWER SUPPLIES ASSEMBLY REAR VIEW 2/2	11
FIGURE 12 - INTERCONNECTIONS AND RIC SCHEMATIC 1/1	12

1 Part List

- Pozidriv screwdriver #1 and # 2.
- Torx T-10 screwdriver (# 99-10XTD)
- 1x Sharp blade
- 1x IF filter CFWS455DY (Murata): Full channel ONLY.
- T800-04-000 RSSI PCB
- 1x EEPROM module (Dataradio 050-03375-000)
- Paragon Radio Programming procedure 20160-54.00
- 1x piece of wire: gauge 26, 0.5” long
- 2x piece of wire: gauge 26, 1.5” long
- 1x piece of wire: gauge 26, 2.0” long

Production procedure			<i>DATARADIO Inc.</i>		Page 2 of 12
Authors: Michel Martin Nicolas Savard	Validated: M. Martin	Approved:	Procedure: 164-20006-031	Rev. date: 2000-07-24	Rev: 1.0
Radio Interface Bulletin					
Tait UHF Base Series II (diversity)					

2 Mechanical & Electrical Interface

Tait UHF T800 series II base station should contain:

- 2x T855-20 Receiver (25KHz channel) rev. **220-01396-03A** or T855-25 (12.5KHz channel)
- 2x RSSI option PCB T800-04-0000 installed in the T-855-2x module IF section.
- 1x T857-2x Exciter rev. **220-01398-03A & 220-01398-04**
- 1x T859 100W PA (available only in the 400-520 MHz band)
- 1x T800-22-00PD (include T800-50-0001 special backplane)

Note 1: The module pinout for both Series I and Series II chassis are compatible

Note 2: No modification required to backplane T800-50-0001

Note 3: After Module modification has been performed, refer to procedure 20160-54-00 (Series II Radio programming) and to procedure 20161-41a.00 (Paragon/PD mechanical assy.)

2.1 T857 Exciter module modifications revision 220-01398-03A

Note: modification below applies to exciter PCB rev. **220-01398-03A**

1. Unscrew Pozidriv screws #1 on the front panel to slide out the module
2. On each side of the module, unscrew the 14 Pozidriv #2 screws and remove both covers.
3. On the top side (handle side), locate and remove transformer T210 from the audio processor circuit. Refer to Figure 1 page 5.
4. On the top side (handle side), place and solder the EEPROM board at the same location of T210. Make sure not to invert the PCB position. Refer to Figure 1 page 5.
5. On the bottom side, cut the trace between pin 1 of T210 and the pad going to pin 4 of DRANGE connector (PL100) Refer to Figure 2 page 5
6. On the bottom side, solder a 2" wire (26AWG) from the +9 volt feedthrough (pad 230) to pin 1 of T210. Refer to Figure 2 page 5
7. Remove R291 (0 ohm res.), R259 (22K res.) and C265 (4u7 cap) (T-857 Audio Processor section. Refer to Figure 3 page 6
8. Solder a short wire (gauge 26, 0.5" long) from feedthrough connected to SK200 pin 3 to C265 negative side pad. Refer to Figure 3 page 6
9. Set the Exciter to the Fast Transmit Turnon mode (Fast TX Key) by soldering a zero ohm resistor at SL501. Refer to Figure 5 page 7
10. Re-align according to the Paragon production procedure.
11. Reinstall the covers and screws (note cover screws should be not torque over to 12lb-in).

Note 1: Feedthrough must be cleaned of any varnish or coating.

Note 2: The wide band audio i/p (TXA) will then be available at "CTCSS" connected to PL100 pin 8 (DB-15 connector).

Note 3: The BDLC has to be set to AC coupled

Production procedure			DATARADIO Inc.		Page 3 of 12
Authors: Michel Martin Nicolas Savard	Validated: M. Martin	Approved:	Procedure: 164-20006-031	Rev. date: 2000-07-24	Rev: 1.0
Radio Interface Bulletin					
Tait UHF Base Series II (diversity)					

2.2 T857 Exciter module modifications revision 220-01398-04

Note: modification below applies to exciter PCB **rev. 220-01390-04**

1. Unscrew Pozidriv screws #1 on the front panel to slide out the module
2. On each side of the module, unscrew the 14 Pozidriv #2 screws and remove both covers.
3. On the top side (handle side), locate and remove transformer T210 from the audio processor circuit.
Refer to Figure 1 page 5
4. On the top side (handle side), place and solder the EEPROM board at the same location of T210.
Make sure not to invert the PCB position. Refer to Figure 1 page 5
5. On the bottom side, cut the trace between pin 1 of T210 and the pad going to pin 4 of DRANGE connector (PL100) Refer to Figure 2 page 5
6. On the bottom side, solder a 2" wire (26AWG) from the +9 volt feedthrough (pad 230) to pin 1 of T210. Refer to Figure 2 page 5
7. Remove R291 (0 ohm res.), R259 (22K res.) and C265 (4u7 cap) (T-857 Audio Processor section).
Refer to Figure 4 page 7
8. Solder a short wire (gauge 26, 0.5" long) from feedthrough connected to SK200 pin 1 to C265 negative side pad (pad near of P290). Refer to Figure 4 page 7
9. Set the Exciter to the Fast Transmit Turnon mode (Fast TX Key) by soldering a zero ohm resistor at SL501. Refer to Figure 5 page 7
10. Re-align according to the Paragon production procedure.
11. Reinstall the covers and screws (note cover screws should be not torque over to 12lb-in).

Note 1: Feedthrough must be cleaned of any varnish or coating.

Note 2: The wide band audio i/p (TXA) will then be available at "CTCSS" connected to PL100 pin 8 (DB-15 connector).

Note 3: The BDLC has to be set to AC coupled

Production procedure			<i>DATARADIO Inc.</i>		Page 4 of 12
Authors: Michel Martin Nicolas Savard	Validated: M. Martin	Approved:	Procedure: 164-20006-031	Rev. date: 2000-07-24	Rev: 1.0
Radio Interface Bulletin					
Tait UHF Base Series II (diversity)					

2.2 T855 Receiver module modifications

Note: modification below applies to exciter PCB # 220-01396-03A

1. Unscrew Pozidriv screws #1 on the front panel to slide out the module
2. On each side of the module, unscrew the 14 Pozidriv #2 screws and remove both covers.
3. On the top side (handle side), locate and remove transformer T210 from the audio processor circuit. Refer to Figure 6 page 8
4. On the top side (handle side), place and solder the EEPROM board at the same location of T210. Make sure not to invert the PCB position. Figure 6 page 8
5. On the bottom side, cut the trace between pin 1 of T210 and the pad going to pin 4 of DRANGE connector (PL100) Refer to Figure 7 page 8
6. On the bottom side, solder a 1.5" wire (26AWG) from the +9 volts feedthrough (pad 201) to pin 4 of T210. Refer to Figure 7 page 8
7. Remove %R223, a 10 ohm resistor (T-855 Audio Processor section). Refer to Figure 8 page 9
8. Solder a 100 ohm resistor (0805 5%) to %R349 location (T-855 I-F section). Refer to Figure 8 page 9
9. **Full channel** RX (T855-20), remove the IF filter &XF302 (CFW455E) and replace it with a CFWS455DY (Murata). Refer to Figure 9 page 9
10. **Half channel** RX (T855-25), do NOT replace the IF filter. Keep the original one (i.e. CFW455G)
11. Install the RSSI PCB T800-04-0000 at SK320 & SK330. Add some silicone on the top, between the PCB and IF cavity's wall. Refer to Figure 9 page 9
12. Re-align according to the Paragon production procedure.
13. Reinstall cover and screws (note cover screws should be not torque over to 12lb-in).

Note 1: these steps must be done for the second receiver to.

Note 2: The wide band audio o/p (RXA) will then be available at "Audio 1" connected to PL100 pin 6 DB-15 (connector).

Note: See next pages for modification location details:

Production procedure			DATARADIO Inc.		Page 5 of 12
Authors: Michel Martin Nicolas Savard	Validated: M. Martin	Approved:	Procedure: 164-20006-031	Rev. date: 2000-07-24	Rev: 1.0
Radio Interface Bulletin					
Tait UHF Base Series II (diversity)					

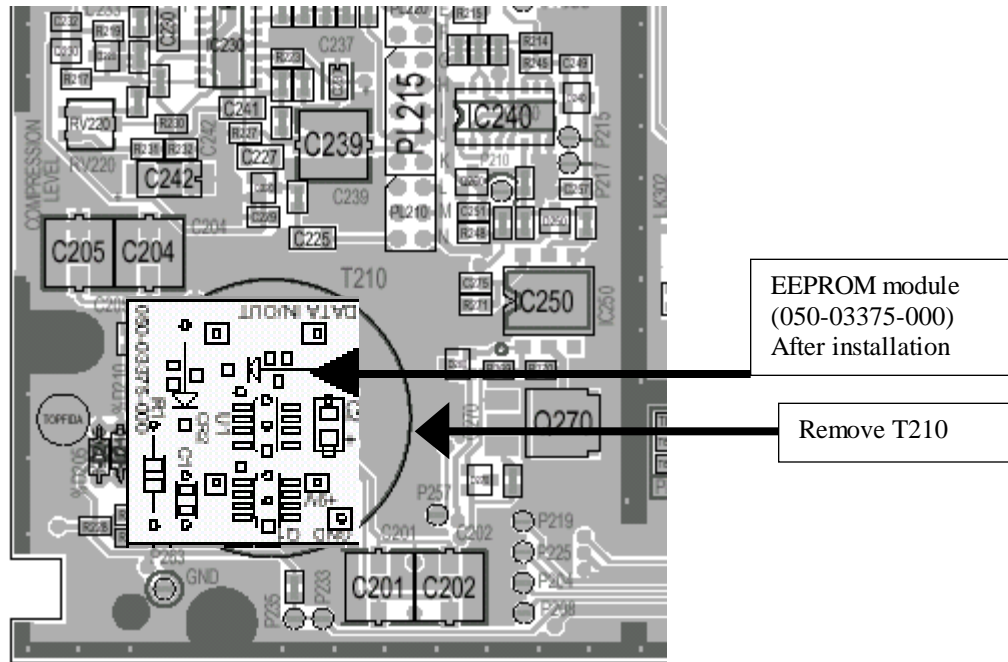

Figure 1- T857 Exciter PCB (rev 220-01398-(03A & 04)), Top Side (EEPROM module) 1/2

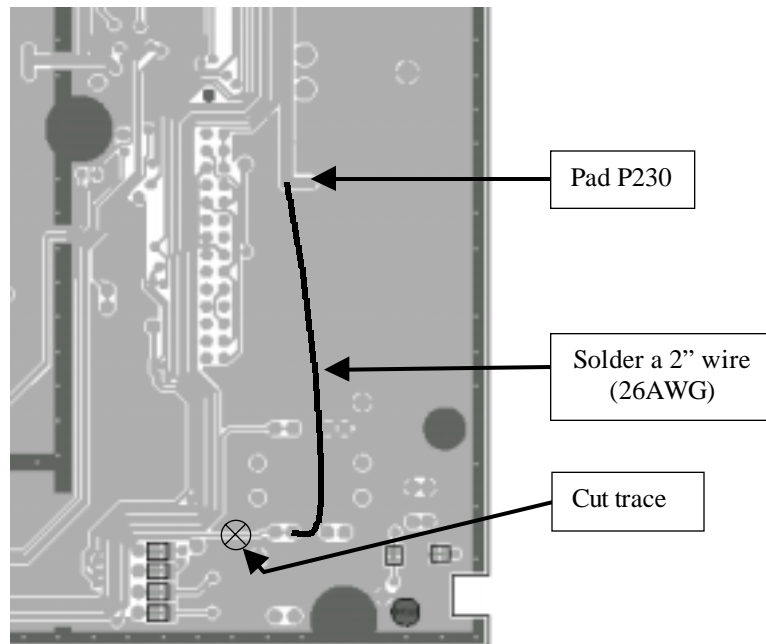

Figure 2- T857 Exciter PCB (rev 220-01398-(03A & 04)), Bottom side (EEPROM module) 2/2

Production procedure			DATARADIO Inc.		Page 6 of 12
Authors: Michel Martin Nicolas Savard	Validated: M. Martin	Approved:	Procedure: 164-20006-031	Rev. date: 2000-07-24	Rev: 1.0
Radio Interface Bulletin					
Tait UHF Base Series II (diversity)					

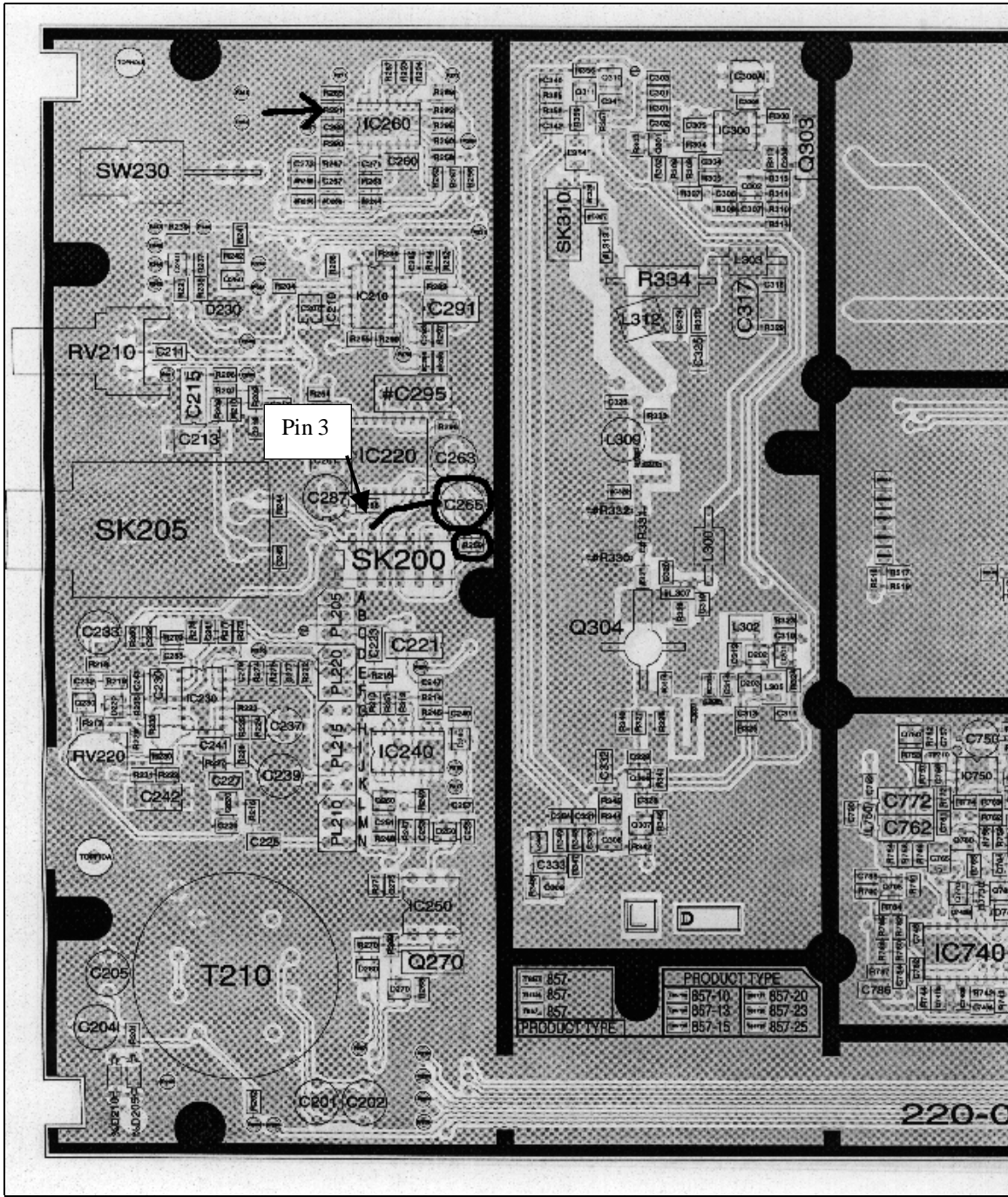

Figure 3 - T857 Exciter PCB (rev 220-01398-03A), Top Side 1/1

Production procedure			DATARADIO Inc.		Page 7 of 12
Authors: Michel Martin Nicolas Savard	Validated: M. Martin	Approved:	Procedure: 164-20006-031	Rev. date: 2000-07-24	Rev: 1.0
Radio Interface Bulletin					
Tait UHF Base Series II (diversity)					

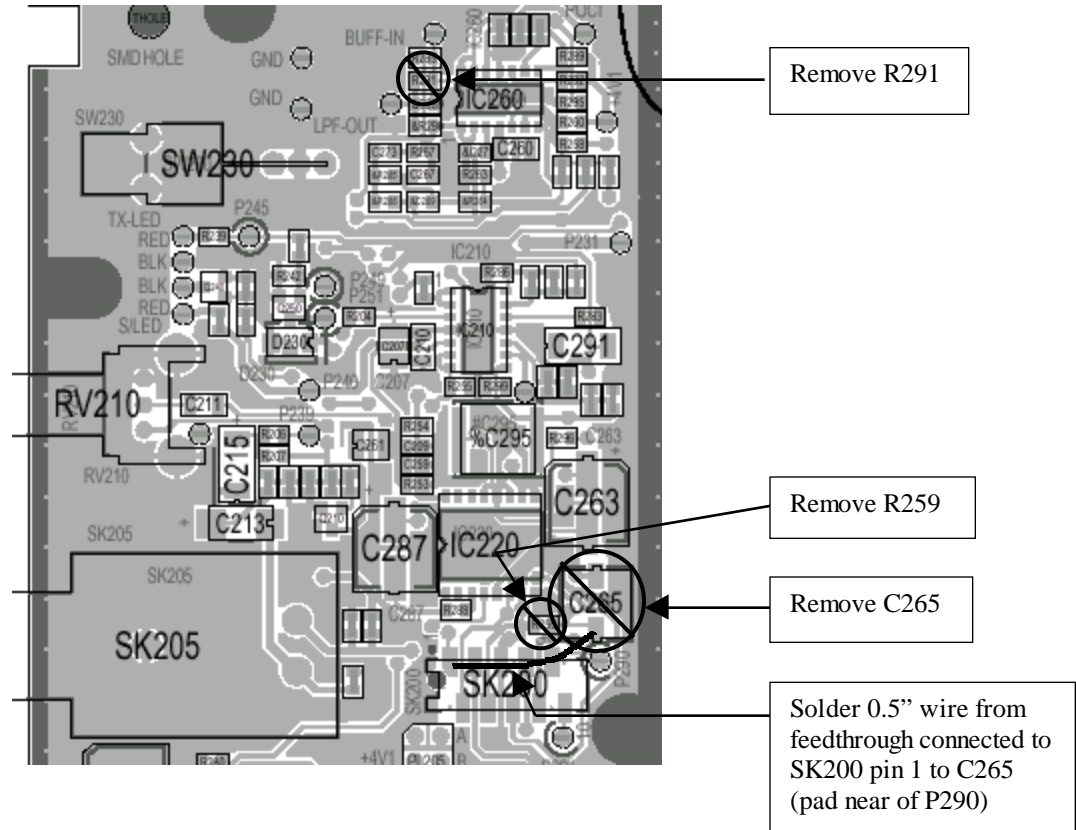

Figure 4 - T857 Exciter PCB (rev 220-01398-04), Top Side 1/2

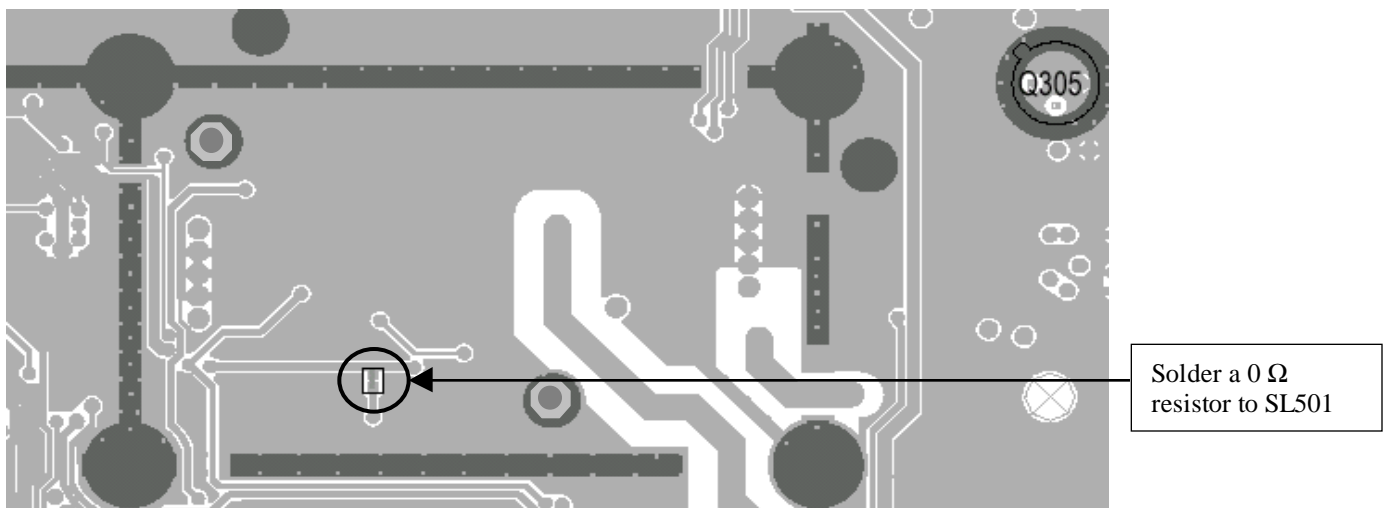
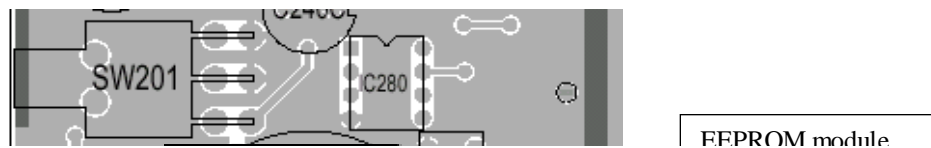

Figure 5 - T857 Exciter PCB (rev 220-01398-(03A &04), Bottom Side (fast Txkey setting) 2/2



Production procedure			<i>DATARADIO Inc.</i>		Page 8 of 12
Authors: Michel Martin Nicolas Savard	Validated: M. Martin	Approved:	Procedure: 164-20006-031	Rev. date: 2000-07-24	Rev: 1.0
Radio Interface Bulletin					
Tait UHF Base Series II (diversity)					

Figure 6 - 855 Receiver PCB, Top Side (EEPROM module) 1/4

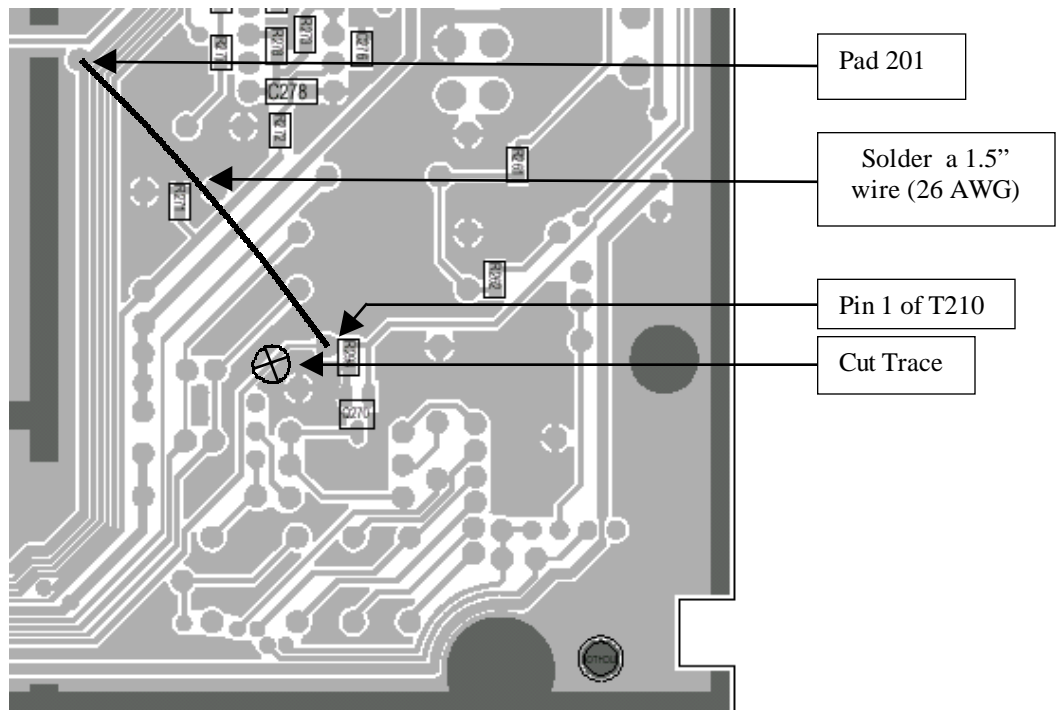

Figure 7 - 855 Receiver PCB, Bottom Side (EEPROM module) 2/4

Production procedure			<i>DATARADIO Inc.</i>		Page 9 of 12
Authors: Michel Martin Nicolas Savard	Validated: M. Martin	Approved:	Procedure: 164-20006-031	Rev. date: 2000-07-24	Rev: 1.0
Radio Interface Bulletin					
Tait UHF Base Series II (diversity)					

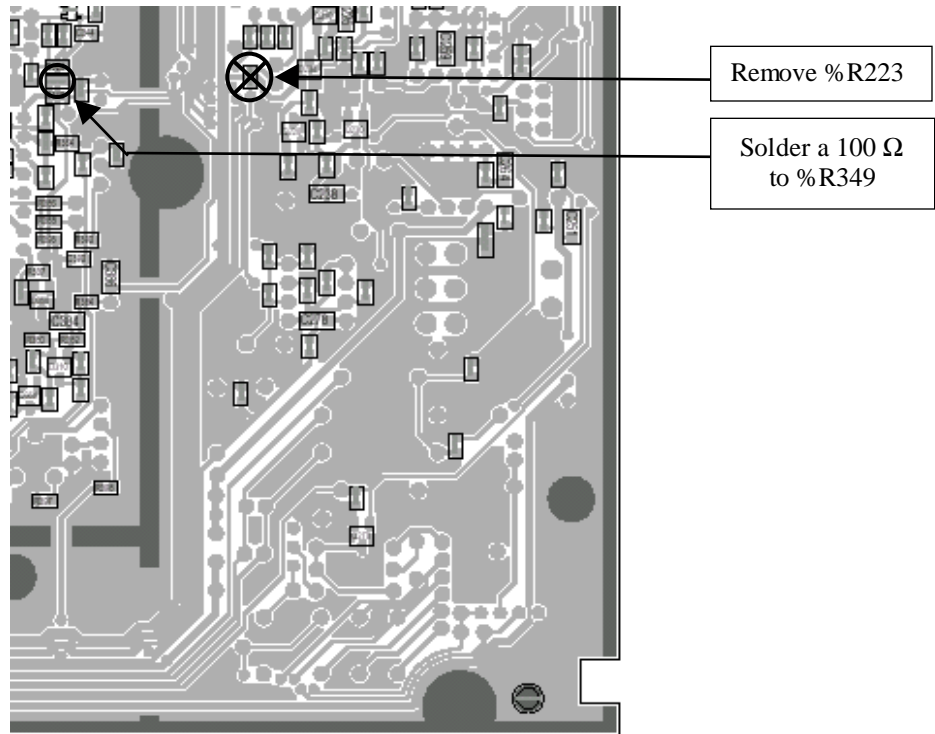

Figure 8 - T855 receiver PCB, Bottom Side 3/4

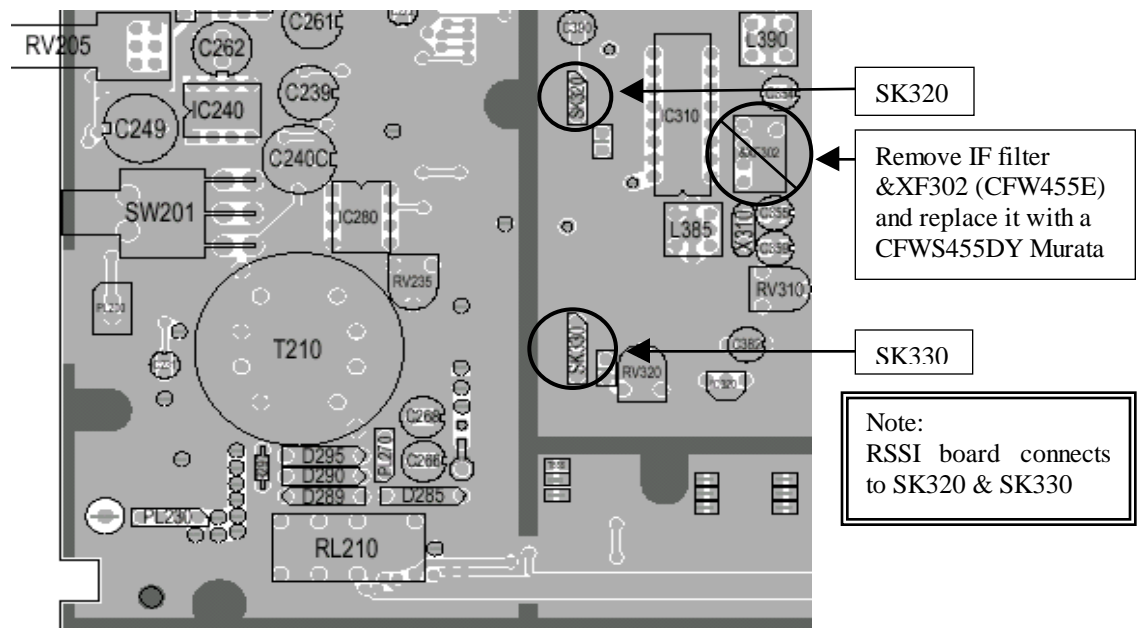

Figure 9 - T855 receiver PCB, Top Side 4/4

Production procedure			DATARADIO Inc.		Page 10 of 12
Authors: Michel Martin Nicolas Savard	Validated: M. Martin	Approved:	Procedure: 164-20006-031	Rev. date: 2000-07-24	Rev: 1.0
Radio Interface Bulletin					
Tait UHF Base Series II (diversity)					

FRONT VIEW

Air Flow

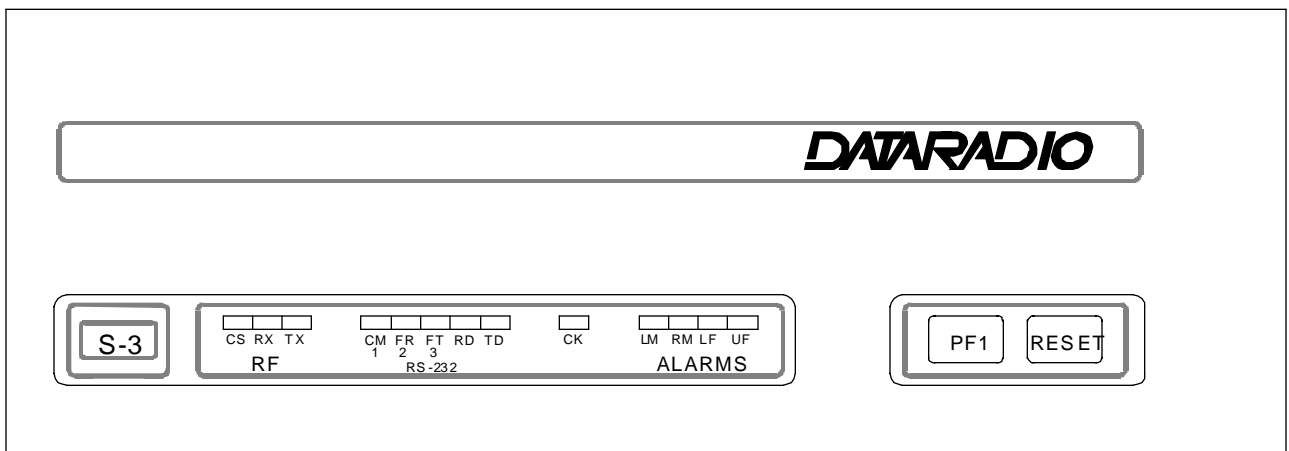
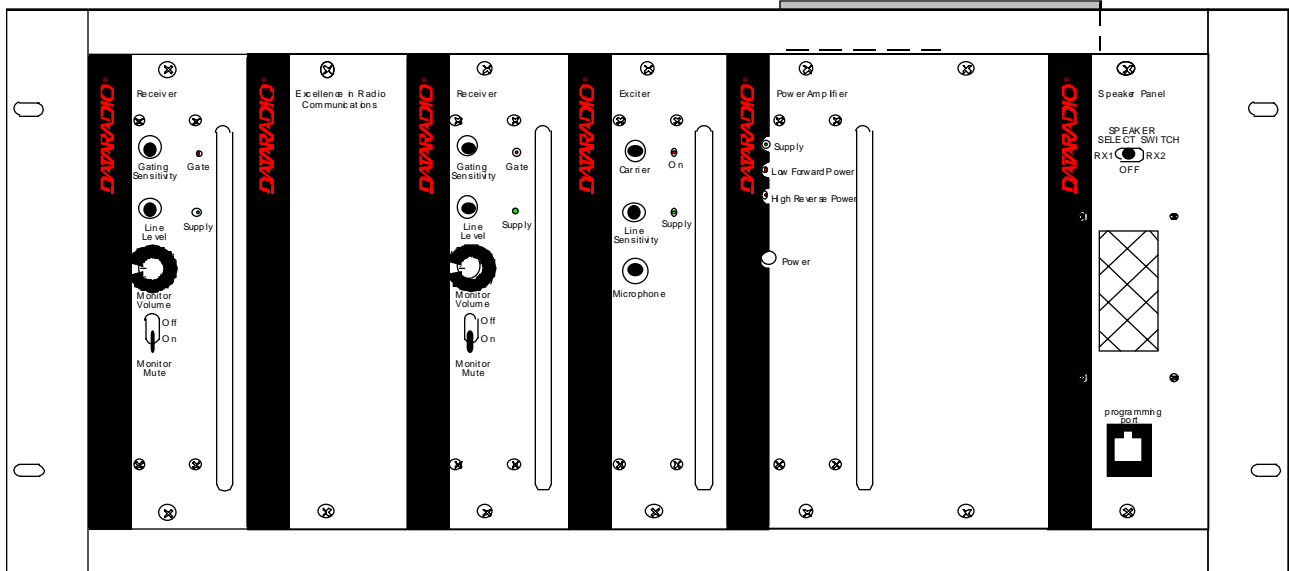

Figure 10 – Typical radio and power supplies assembly front view 1/2

Production procedure			DATARADIO Inc.		Page 11 of 12
Authors: Michel Martin Nicolas Savard	Validated: M. Martin	Approved:	Procedure: 164-20006-031	Rev. date: 2000-07-24	Rev: 1.0
Radio Interface Bulletin					
Tait UHF Base Series II (diversity)					

REAR VIEW

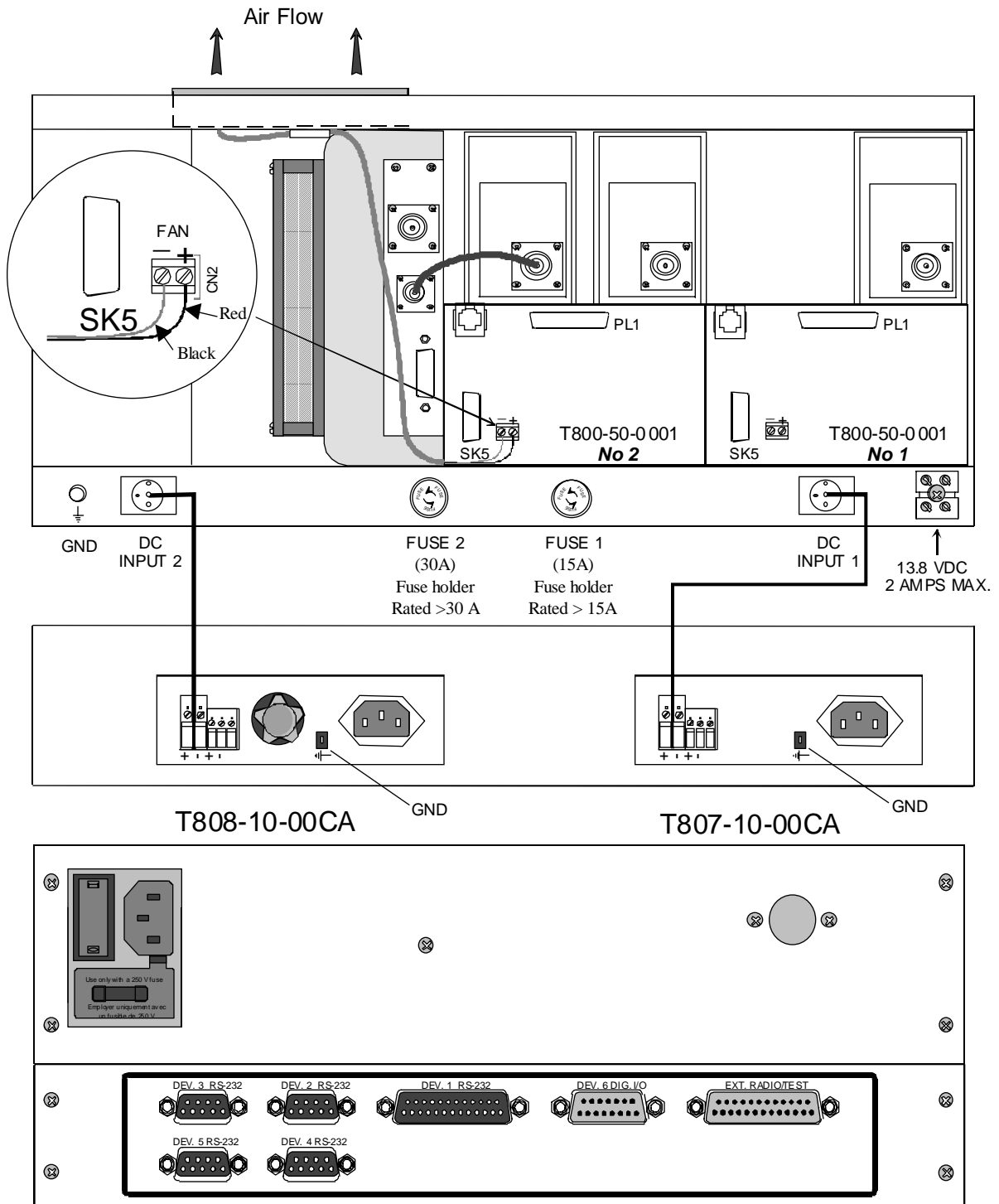
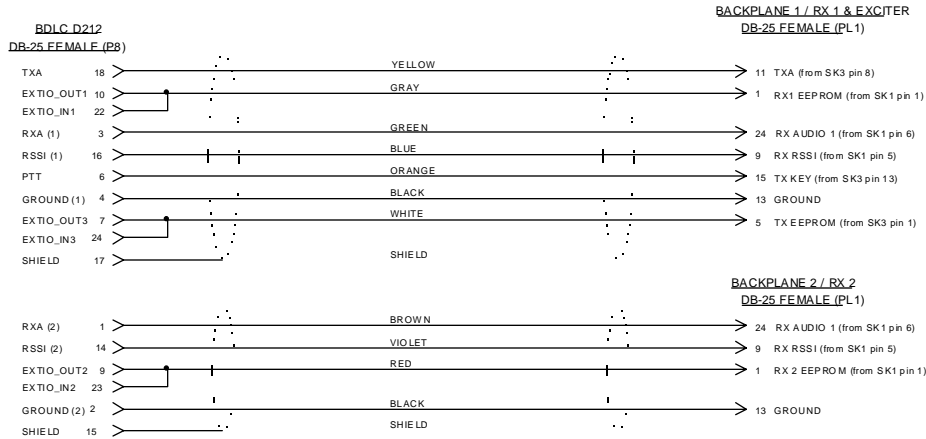

Figure 11 - Typical radio and power supplies assembly rear view 2/2

Interconnections

COMPANY CONFIDENTIAL:
THIS INFORMATION IS THE PROPERTY OF DATARADIO INC.
NO REPRODUCTION OR DISTRIBUTION WITHOUT PERMISSION.



ITEM	DESCRIPTION	P/N
1	DB25 FEMALE SOLDER CUP CONNECTOR	HAZ 25S-E
2	STRAIGHT-THROUGH PLASTIC HOOD AND GROMMET WITH 4/40 SCREW LOCKS	C88311004
3	SHIELDED 10 CONDUCTOR CABLE AWG #24	CSA CMG 60-C FT-4 LL61365 CSA AWM II A/B 105C 600 VOLTS #24 AWG RU AWM E107863 300 VOLTS VW-1 80C

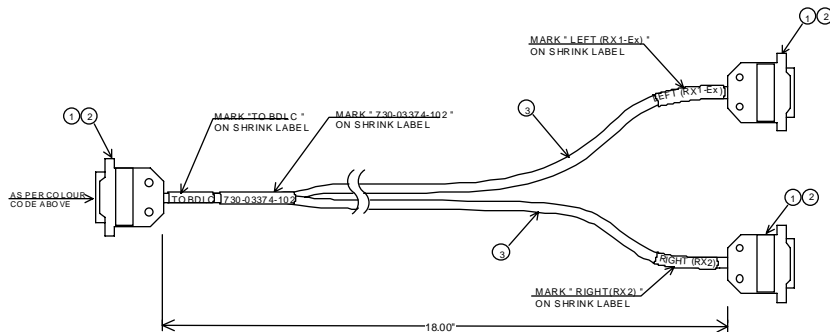

2	CHANGED 2 CONNECTORS (PL1) TO DB25 FEMALE	000505	
1	RELEASED	000412	
REV	DESCRIPTION	DATE	APPR
DATARADIO INC.			
DESIGNER M.MARTIN / F.RODRIGUEZ	GEN TOLERANCE 100" X.XXX - 0.00"	①	
DRAWN D. NGUYEN	MAT	SCALE	N.T.S.
CHECKED M.MARTIN / F.RODRIGUEZ	NEXT ASSY	DATE	000505
PARAGON / PD RADIO INTERFACE CABLE (FOR BACKPLANE T800-50-0001)			
SIZE B	PART No 730-03374-102	SHEET	1/1
DRAWING No 265-03374-102			

Figure 12 - Interconnections and RIC schematic 1/1