

Natural Gas Solutions

2.4GZ OpenWay Gas Module Installation Guide

Putting knowledge to work.

Identification

2.4GZ OpenWay Gas Module Installation Guide
DRAFT PUB-nnnn-xxx

Copyright

© 2007 Itron, Inc. All rights reserved.

Your company has the right to reproduce this contract document, provided that such reproduction shall be subject to the same use and disclosure restrictions contained in the Confidentiality and Non-Disclosure paragraphs in the Sales Contract.

Applicable Patents

U.S. Patent Numbers: TBD
Canadian Patent Numbers: TBD

Transportation Classification

Itron classifies and ships model 2.4GZ OpenWay Gas Modules as a non-hazardous material. The proper shipping name is **Lithium Batteries contain in Equipment, Class 9, UN3091, Packing Group II**.

The Federal Aviation Administration prohibits operating transmitters and receivers on all commercial aircraft. When powered, the 2.4GZ OpenWay Gas Module is considered an operating transmitter and receiver and cannot be shipped by air.

Compliance Statement

This device must be permanently mounted such that it retains a distance of 20 centimeters (7.9 inches) from all persons in order to comply with FCC and Industry Canada RF exposure levels.

Industry Canada

Operation is subject to the following two conditions: (1) this device may not cause interference, and (2) this device must accept any interference, including interference that may cause undesired operation of the device.

FCC

This device complies with Part 15 of the FCC Rules. Operation of this device is subject to the following two conditions: (1) this device may not cause harmful interference, and (2) this device must accept any interference received, including interference that may cause undesired operation.

Modification and Repairs

To ensure FCC and Industry Canada compliance and system performance, this device and antenna shall not be changed or modified in any way without the express written approval of Itron, Inc. Any unauthorized modification will void the user's authority to operate the equipment.

Meter Installation/Removal

In the event of malfunction, all repairs should be performed by Itron. It is the responsibility of users requiring service to report the need for service to Itron.

Related Documents

Endpoint-Link Programming Guide (TDC-XXXX)

Trademark Notice

OpenWay and Itron are both registered trademarks of Itron, Inc. All other product names and logos in this documentation are used for identification purposes only and may be trademarks or registered trademarks of their respective companies.

Suggestions

If you have comments or suggestions on how we may improve this documentation, send them to TechnicalCommunicationsManager@itron.com.

Support

If you have questions or comments about this application, contact Itron Technical Support:

- Mail: Itron, Inc. Attention: Customer Care, 2111 N Molter Road, Liberty Lake, WA 99019
- E-mail: support@itron.com
- Phone: 1 800 635 8725
-

Web Support

<http://eKnowledge.itron.com>

Itron Website

<http://www.itron.com>

Document Revision

The content of this publication was last edited on 5/30/2008.

Contents

Chapter 1 Getting Started	1
Specifications	1
Meter Compatibility List	2
Chapter 2 American Meter Installation	5
Chapter 3 American Meter Installation	7
Installation Prerequisites	7
Materials Supplied By Itron	7
Materials Supplied By You	7
Replacement Screws	7
Preinstallation Preparations	8
Installing the 2.4GZ OpenWay Gas Module	8
Remove the Existing Index	8
Assemble the OpenWay Gas Module	11
Program the OpenWay Gas Module	16
Attach the OpenWay Gas Module to the Meter	18
Chapter 4 Sensus Meter Installation	23
Chapter 5 Sensus Meter Installation	25
Installation Prerequisites	25
Materials Supplied By Itron	25
Materials Supplied By You	25
Replacement Screws	25
Preinstallation Preparations	26
Installing the 2.4GZ OpenWay Gas Module	26
Remove the Existing Index	26
Assemble the OpenWay Gas Module	28
Program the OpenWay Gas Module	30
Attach the OpenWay Gas Module to the Meter	31

CHAPTER 1

Getting Started

The 2.4GZ OpenWay Gas Module is Itron's latest module. OpenWay Gas Modules are radio-frequency (RF) devices that transmit meter data. The 2.4GZ can be read by OpenWay CENTRON electric meters and is part of the Itron OpenWay solution for combo gas and electric utilities.

This installation guide shows you how to install the 2.4GZ OpenWay Gas Module on meters from a variety of manufacturers. To ensure you have a meter that is compatible with the 2.4GZ OpenWay Gas Module, refer to the [Meter Compatibility List](#) on page 2.

An FCC or IC license is not required to read 2.4GZ OpenWay Gas Modules.

Specifications

The functional and operational specifications for the 2.4GZ OpenWay Gas Module are listed below.

Functional Specifications	Description
Power Source	Two "A" cell lithium batteries
Tamper Detection	Tilt tamper and magnetic tamper
FCC Compliance	Part 15 certified
Industry Canada Compliance	RSS-210 certified
Measurement Canada Approval	Pending
Intrinsic Safety	UL Class I, Division 1, Groups C and D pending
Product Identification	Numeric and barcoded and serial number
Construction Materials	Gray polycarbonate back plate with Santoprene® gasket; clear polycarbonate front cover; encapsulated electronics

Operational Specifications	Description
Operating Temperatures	-40° to 158° F (-40° to +70° C)
Operating Humidity	5 to 95percent relative humidity
Frequency Band	2.4 to 2.475 GHz ISM band
Modulation	Direct Sequence Spread Spectrum
Data Integrity	Verified in every data message

Meter Compatibility List

The following meters are compatible with the 2.4GZ OpenWay Gas Module. Due to continuous research, product improvements, and enhancements, Itron reserves the right to change this list at any time.

To ensure you have the latest Meter Compatibility list available, contact your Itron representative.

Mfgr.	Model	Desc.	Class	Comments	OpenWay Gas Module	Part No.
American/ Canadian	W75AL		Residential	Aluminum case Meters Only	2.4GZ	OWG-5000-001
American/ Canadian	AL-175		Residential	Aluminum case meters only	2.4GZ	OWG-5000-001
American/ Canadian	AC-175		Residential	Aluminum case meters only	2.4GZ	OWG-5000-001
American/ Canadian	AT-175		Residential	Aluminum case meters only	2.4GZ	OWG-5000-001
American/ Canadian	ALC-175		Residential	Aluminum case meters only	2.4GZ	OWG-5000-001
American/ Canadian	AT-210		Residential	Aluminum case meters only	2.4GZ	OWG-5000-001
American/ Canadian	AL-225	Canada only	Residential	Aluminum case meters only	2.4GZ	OWG-5000-001
American/ Canadian	AL-250		Residential	Aluminum case meters only	2.4GZ	OWG-5000-001
American/ Canadian	AR-250		Residential	Aluminum case meters only	2.4GZ	OWG-5000-001
American/ Canadian	AC-250		Residential	Aluminum case meters only	2.4GZ	OWG-5000-001
American/ Canadian	AT-250		Residential	Aluminum case meters only	2.4GZ	OWG-5000-001
American/ Canadian	AM-250		Residential	Aluminum case meters only	2.4GZ	OWG-5000-001
American/ Canadian	AL-310		Residential	Aluminum case meters only	2.4GZ	OWG-5000-001
American/ Canadian	AL-350		Residential	Aluminum case meters only	2.4GZ	OWG-5000-001
American/ Canadian	AT-350		Residential	Aluminum case meters only	2.4GZ	OWG-5000-001
American/ Canadian	AL-425		Residential	Aluminum case meters only	2.4GZ	OWG-5000-001

American/ Canadian	AC-630		Residential	Aluminum case meters only	2.4GZ	OWG-5000-001
American/ Canadian	5B 225		Residential	Aluminum case	2.4GZ	OWG-5000-001
Sensus/Invensys/ Equimeter/ Rockwell	R-175	11 Tooth	Residential	Compatible with 2 foot drive index; 1 foot drive has 24 teeth	2.4GZ	OWG-5000-002
Sensus/Invensys/ Equimeter/ Rockwell	R-200	11 Tooth	Residential		2.4GZ	OWG-5000-002
Sensus/Invensys/ Equimeter/ Rockwell	RT-200	11 Tooth	Residential		2.4GZ	OWG-5000-002
Sensus/Invensys/ Equimeter/ Rockwell	RT-230	11 Tooth	Residential		2.4GZ	OWG-5000-002
Sensus/Invensys/ Equimeter/ Rockwell	R-275	11 Tooth	Residential		2.4GZ	OWG-5000-002
Sensus/Invensys/ Equimeter/ Rockwell	RT-275	11 Tooth	Residential		2.4GZ	OWG-5000-002
Sensus/Invensys/ Equimeter/ Rockwell	R-315	11 Tooth	Residential		2.4GZ	OWG-5000-002
Sensus/Invensys/ Equimeter/ Rockwell	250	11 Tooth	Residential		2.4GZ	OWG-5000-002
Sensus/Invensys/ Equimeter/ Rockwell	310	11 Tooth	Residential		2.4GZ	OWG-5000-002
Sensus/Invensys/ Equimeter/ Rockwell	S-110	11 Tooth	Residential		2.4GZ	OWG-5000-002
Sensus/Invensys/ Equimeter/ Rockwell	S-200	11 Tooth	Residential		2.4GZ	OWG-5000-002
Sensus/Invensys/ Equimeter/ Rockwell	175-S	11 Tooth	Residential		2.4GZ	OWG-5000-002
Sensus/Invensys/ Equimeter/ Rockwell	RT-100	18 Tooth	Residential		2.4GZ	OWG-5000-004
Sensus/Invensys/ Equimeter/ Rockwell	S-190	11 Tooth	Residential		2.4GZ	OWG-5000-002
Sensus/ Invensys/ Equimeter/ Rockwell	S-120	11 Tooth	Residential		2.4GZ	OWG-5000-002
Sensus/Invensys/ Equimeter/ Rockwell	T-120	11 Tooth	Residential		2.4GZ	OWG-5000-002
Sensus/Invensys/ Equimeter/ Rockwell	T-110	11 Tooth	Residential		2.4GZ	OWG-5000-002

Sensus/Invensys/ Equimeter/ Rockwell	R-415	18 Tooth	Residential		2.4GZ	OWG-5000-004
Sensus/Invensys/ Equimeter/ Rockwell	RT-360	18 Tooth	Residential		2.4GZ	OWG-5000-004
Sensus/Invensys/ Equimeter/ Rockwell	MR8 (R-275 Metric)	16 Tooth	Residential		2.4GZ	OWG-5000-003
Sensus/Invensys/ Equimeter/ Rockwell	MR12 (R-415 Metric)	16 Tooth	Residential		2.4GZ	OWG-5000-003

CHAPTER 2

American Meter Installation

American Meter Installation

This chapter shows you how to install a 2.4GZ OpenWay Gas Module on an American meter.

Before installing the 2.4GZ OpenWay Gas Module, verify that you have:

- A compatible meter shown in the Meter Compatibility List.
- A compatible index. Itron 2.4GZ OpenWay Gas Modules can be used with standard dial and direct read (odometer) indexes.
- The list of materials defined under Installation Prerequisites in this chapter.

Installation Prerequisites

The following items are required to install the Itron 2.4GZ OpenWay Gas Module.

Materials Supplied By Itron

The following items are supplied by Itron:

- 2.4GZ OpenWay Gas Modules
- New tamper seals

Materials Supplied By You

You must supply the following items to install, initialize, and check the 2.4GZ OpenWay Gas Module on the meter.

- **Small and medium flat-blade or Phillips screwdrivers** Used to remove and tighten index and index-cover screws.
- **Side-cutting plier/wire snips** Used for cutting wire seals, if necessary.
- **Small putty knife** Used to remove all traces of old gaskets from the meter.
- **Meter seals, wire seals, and seal press** Used to secure the meter from tampering, if necessary.
- **11/32-inch nut driver or other blunt tool** Used to securely seat new tamper plugs over screw holes.
- **Replacement screws** Used to mount 2.4GZ OpenWay Gas Module assembly to meter and index to module assembly backplates.

Replacement Screws

Replacement screws used in this procedure are shown below.

For mounting 2.4GZ OpenWay Gas Module assemblies on meters:

- Use 1/4 - 20 x 5/8-inch slotted, Fillister head screws.

For mounting indexes on 2.4GZ OpenWay Gas Module backplates:

- Use 8 - 32 x 3/16-inch slotted, round head screws.

Preinstallation Preparations

Before installing the 2.4GZ OpenWay Gas Module on a meter, verify that:

- All Itron gas modules are 2.4GZ OpenWay Gas Modules for your brand of gas meters.
- The model numbers of all meters on which the 2.4GZ OpenWay Gas Modules will be installed are included in the Meter Compatibility List.

Installing the 2.4GZ OpenWay Gas Module

There are four major steps to installing the 2.4GZ OpenWay Gas Module on a meter:

- Remove the index
- Assemble the 2.4GZ OpenWay Gas Module
- Program the 2.4GZ OpenWay Gas Module
- Attach the 2.4GZ OpenWay Gas Module to the meter.



NOTE Properly dispose of all unused screws, old index covers, gaskets, tamper seals, and other left-over materials. Do not leave any materials on customer premises.

Remove the Existing Index

The first major step when installing a 2.4GZ OpenWay Gas Module on an American meter is to remove the existing index from the meter.

To Remove the Index

1. Remove any tamper seals from the meter.

2. Detach the index cover from the meter by removing the four screws holding it in place.



3. Examine the index cover screws you just removed. Verify that they are 5/8-inches long and are not corroded.
 - If the screws are the correct length, and are not corroded, keep them for later use.
 - If the screws are an incorrect length or are corroded, dispose of them properly. Use the screws listed in [Replacement Screws](#) on page 7.



TIP You can use the index cover you just removed as a temporary storage location for screws.

4. Unscrew one index mounting screw completely.

Hold one hand beneath the index to catch the screw when it falls out of the index assembly. If it does not fall out by itself, be sure to remove it.

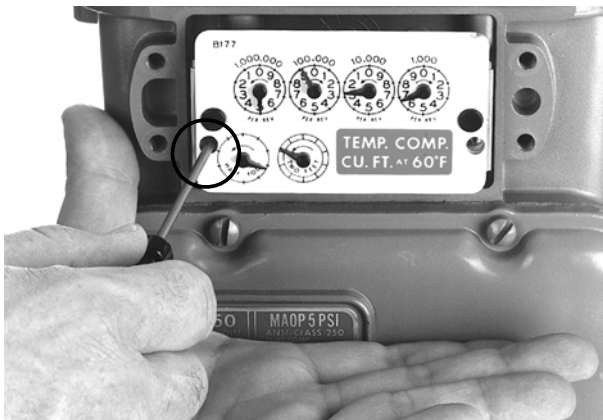

5. Unscrew the other index mounting screw.

While removing this screw, pull the index away from the meter to keep its backplate (1) against the back of the screwhead (2). This prevents the screw from falling out prematurely.

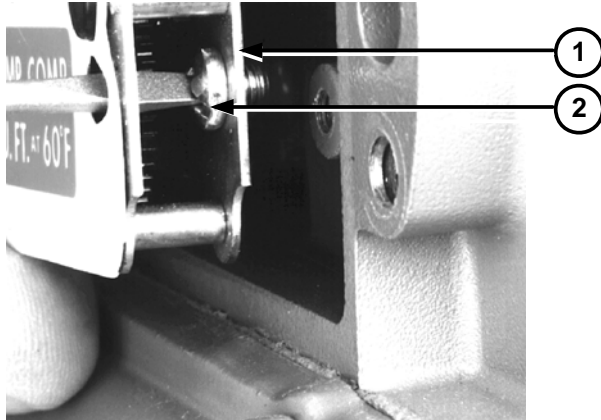

6. Remove the screw from the index once it is completely free of its hole.
7. Set the index aside for the moment. Place it where it will not be damaged; get filled with dirt, rain, or snow; or fall to the ground or floor. The index will be used later in this procedure.
8. Examine the index screws you just removed. Verify that they are 3/16-inch long and are not corroded.
 - If the screws are 3/16-inch long and are not corroded, keep them for later use.
 - If the screws are an incorrect length or are corroded, dispose of them properly. Use 8 - 32 x 3/16-inch screws as described in [Replacement Screws](#) on page 7 instead.
9. Use a putty knife or similar object to completely remove the old index gasket from the meter (if applicable). All traces of the gasket must be removed before the OpenWay Gas Module can be installed.

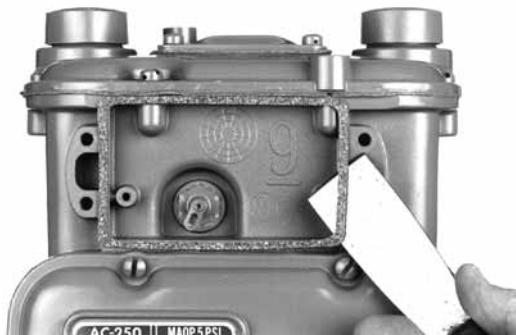

Assemble the OpenWay Gas Module

When installing a 2.4GZ OpenWay Gas Module, the next major step is to create the OpenWay Gas Module assembly by combining the module backplate and cover with the meter index. Follow the procedure below to do so.

To Assemble the OpenWay Gas Module

1. Obtain a new 2.4GZ OpenWay Gas Module.
2. Separate the module backplate (1) from the cover (2).

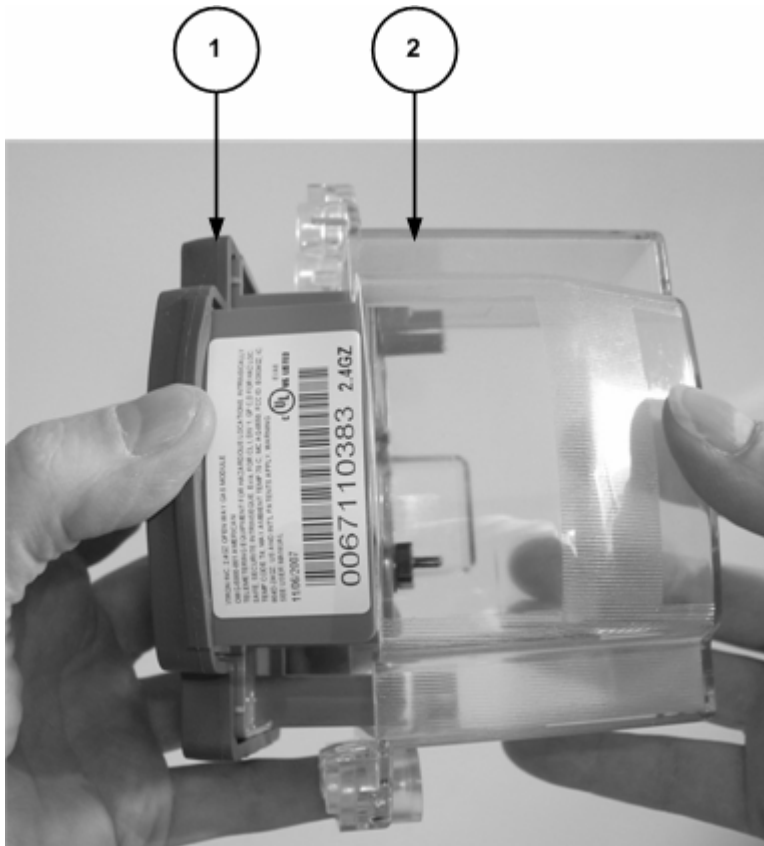

3. Set the new OpenWay Gas Module index cover aside for the moment. Place it where it will not be damaged; get filled with dirt, rain, or snow; or fall to the ground or floor. The index cover will be used later in this procedure.



IMPORTANT Before continuing with the installation, note the following information about American Meter indexes:

- Index wrigglers on one-foot meters have drive slots.

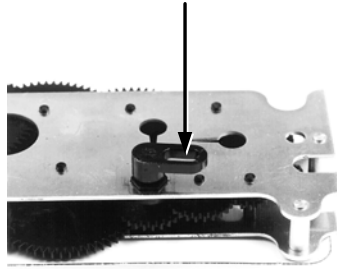

- Index wrigglers on two-foot meters have drive posts.

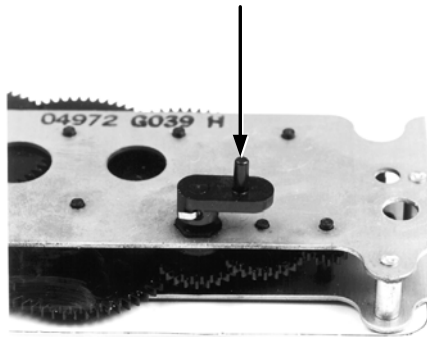

- An index may have mounting screw holes.



- An index may have mounting screw slots.

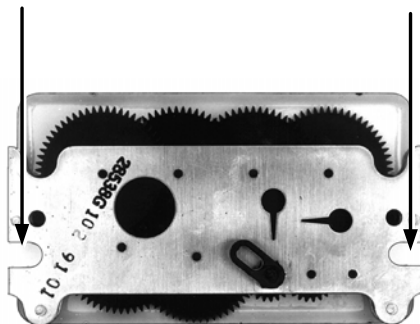

If the index has mounting screw *slots*, skip steps 4 and 5 below. Continue with step 6.

If the index has mounting screw *holes*, perform steps 4 and 5 below, and then skip steps 6 and 7.

4. If the index has mounting screw *holes*, place an index mounting screw (1) in the right-hand mounting screw hole (2). Use one 8 - 32 3/16-inch screw for this step (you can use an original mounting screw if it was the correct size and not corroded; otherwise, use the correct size replacement screw).

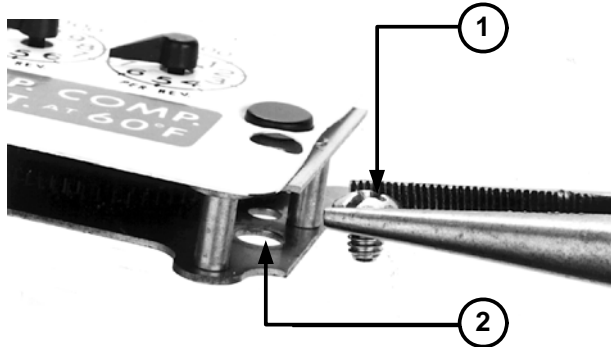

5. Attach the screw to the OpenWay Gas Module backplate's right-hand index mounting post just far enough to hold the screw and end of the index in place.

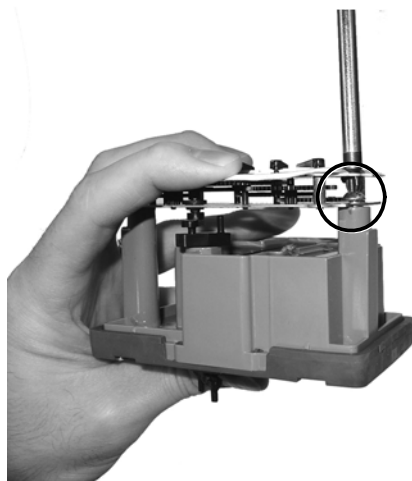

6. If the index has mounting screw *slots*, screw an index mounting screw (1) one to two turns into the OpenWay Gas Module backplate's right-hand index mounting post (2). Use one 8 - 32 x 3/16-inch screw for this step (you can use an original mounting screw if it was the correct size and not corroded; otherwise, use the correct size replacement screw).

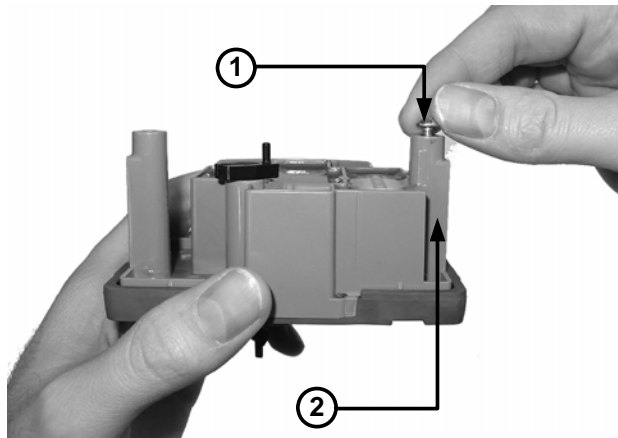

7. Place the index mounting screw slot under the screw head. *Do not* tighten the screw yet.



8. Attach the wiggler to the index and backplate.
 - If the index wiggler has a drive slot (1), place the backplate wiggler's drive post (2) in the index wiggler's drive slot.

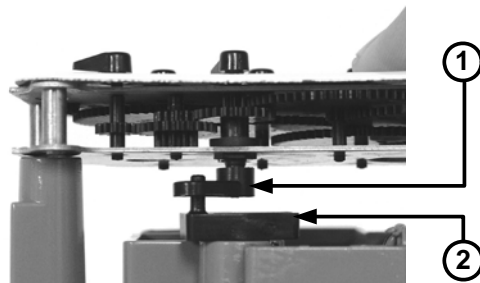

- If the index wiggler has a drive post (1), place the index wiggler's drive post in the backplate wiggler's drive slot (2).

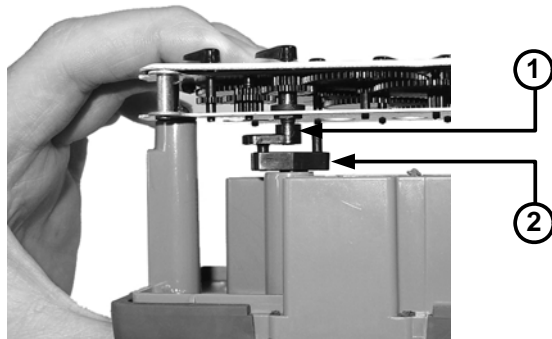

9. Install and tighten the left-hand index mounting screw (for indexes with either mounting screw slots or holes). Use one 8 - 32 x 3/16-inch screw for this step (you can use an original mounting screw if it was the correct size and not corroded; otherwise, use the correct size replacement screw).



10. Tighten the right-hand index mounting screw.
11. Slide the OpenWay Gas Module cover (1) over the index and backplate (2).

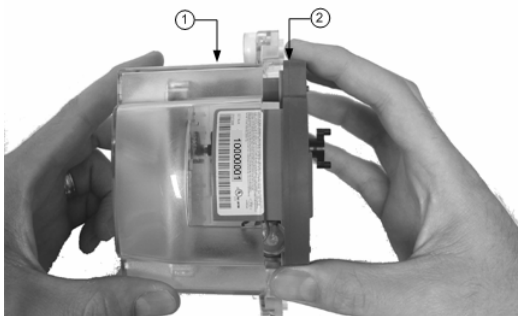

Next, program the OpenWay Gas Module.

Program the OpenWay Gas Module

Once the OpenWay Gas Module has been assembled, the module must be programmed using FieldPro on a laptop with a ZigBee dongle. Refer to FieldPro documentation for programming information.

IMPORTANT You must perform the following programming procedure for the OpenWay Gas Module to function properly.

When programming the OpenWay Gas Module, you must take note of the drive rate shown on the index of American meters.

Examples of 1-foot (1) and 2-foot (2) drive rates are shown below (a 0.05 cubic metre drive rate is not shown). Be sure to program the OpenWay Gas Module based on the drive rate indicated on the index.

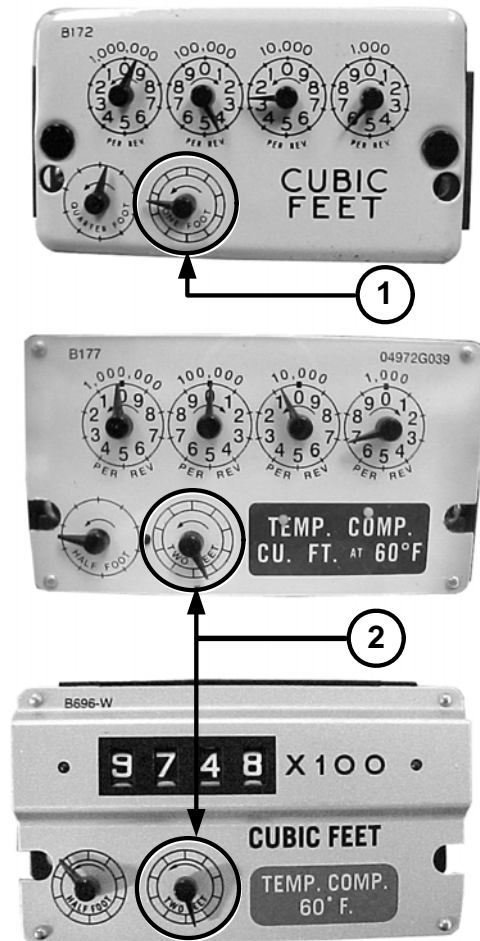

To Program the OpenWay Gas Module

NOTE Itron will be moving to this programming solution in early 2008

1. Using the FC200 and Belt Clip radio, program the reading of the index that was on the meter into the OpenWay Gas Module assembly.

During programming, the OpenWay Gas Module is programmed to the *nearest 100 cubic feet*; the last two digits (the tens and units) are programmed as zeros (0). Once programming is complete, however, the OpenWay Gas Module assembly can be read to the nearest cubic foot.

2. Slowly turn the OpenWay Gas Module drive wiggler two turns in the direction indicated on the index drive rate. This lets you verify the module is counting properly after assembly.



IMPORTANT Do not turn the drive wiggler faster than *one turn per second*.



3. Read the OpenWay Gas Module assembly using the FC200 and Belt Clip radio. Consult the *EndPoint-Link Programming Guide* or other applicable instructions for details on how to read an OpenWay Gas Module.
 - If this reading is higher than the one you programmed in step 1 above, the module assembly is counting correctly.

If the OpenWay Gas Module assembly reading is *not* higher than what was programmed in step 1, replace the module with a new one.

Attach the OpenWay Gas Module to the Meter

After the OpenWay Gas Module has been programmed and is reading correctly, follow the steps below to attach the module to the meter.

To Attach the OpenWay Gas Module to the Meter

1. **For 5B 225 Meters Only:** If you are installing the OpenWay Gas Module on a 5B 225 aluminum meter, cut 1/16-inch off each post of the module wriggler to prevent it from rubbing on the face of the nut that holds the wriggler in place. If you are not installing on a 5B 225 meter, continue to step 2 below.

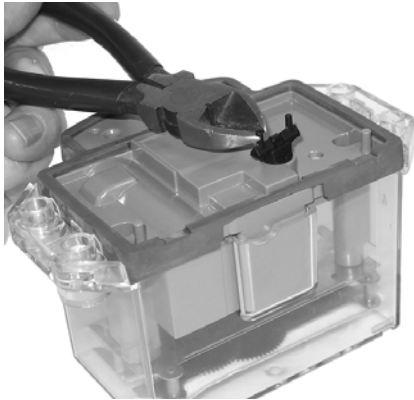

2. Set the wriggler to the desired position for mounting the OpenWay Gas Module assembly to the meter.
 - **For One-Foot Meters:** Align the OpenWay Gas Module assembly wriggler with the meter drive post (as shown below). Make sure the wriggler is perpendicular to the meter drive post.

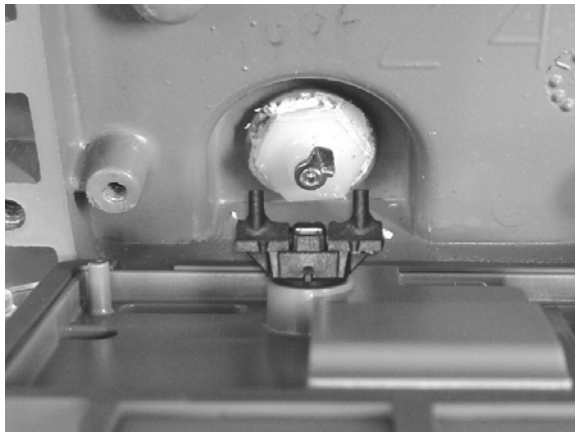

- **For Two-Foot Meters:** Align the OpenWay Gas Module assembly wiggler with the meter drive slot (as shown below). It is acceptable for the pin on the module wiggler to be installed inside or outside of the meter drive slot. For ease of assembly, Itron recommends that the pin on the OpenWay Gas Module wiggler be installed outside of the meter drive slot.

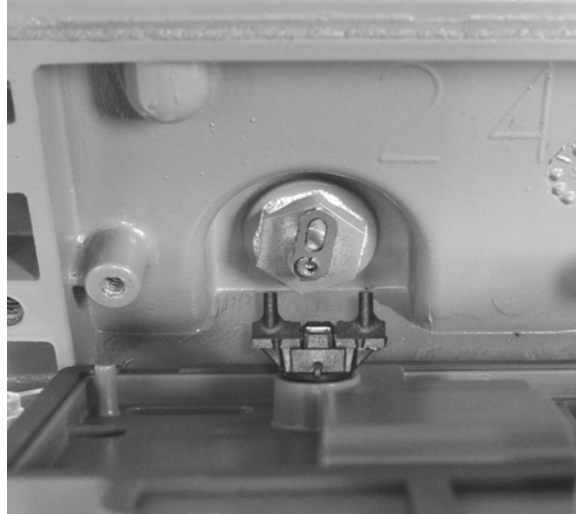

3. Gently place the OpenWay Gas Module assembly on the meter. Align the four screw holes on the module assembly with the holes on the meter.

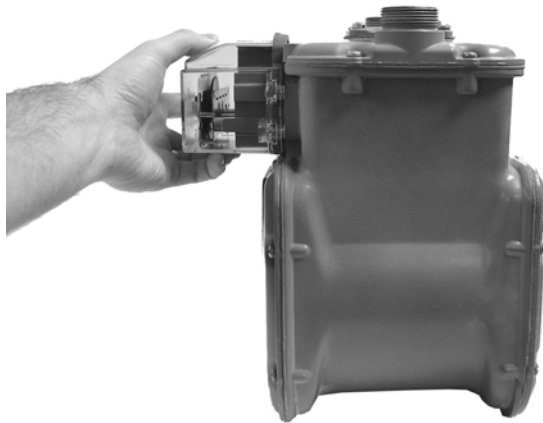

4. Install and tighten all OpenWay Gas Module assembly mounting screws, working in a diagonal pattern as shown below. Tighten the mounting screws to 15 to 20 inch-pounds of torque. Use the 1/4 - 20 x 5/8-inch screws for this step (you can use the original mounting screws if they were the correct size and not corroded; otherwise, use the correct size [Replacement Screws](#) on page 7).

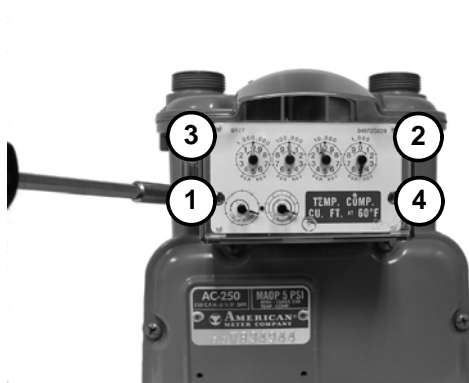

5. Place a new tamper seal over two of the mounting screws as shown below.

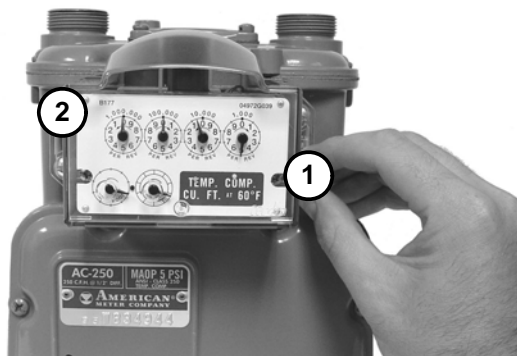

6. Press the new tamper seals into place using the 11/32-inch nut driver (or another similar blunt tool).

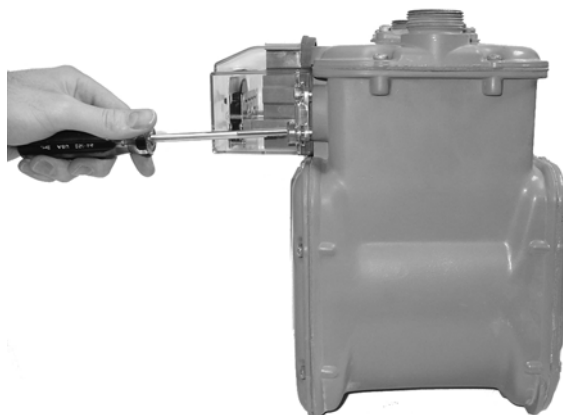

7. Complete any necessary paperwork. Make sure no excess material is left on the customer premises; dispose of it properly.

The OpenWay Gas Module is now installed on the meter.



CHAPTER 4

Sensus Meter Installation

CHAPTER 5

Sensus Meter Installation

This chapter shows you how to install a 2.4GZ OpenWay Gas Module on a Sensus meter. The instructions in this chapter apply to 11-tooth, 16-tooth, and 18-tooth Sensus endpoints.

Installation Prerequisites

The following items are required to install the Itron 2.4GZ OpenWay Gas Module.

Materials Supplied By Itron

The following items are supplied by Itron:

- 2.4GZ OpenWay Gas Modules
- New tamper seals

Materials Supplied By You

You must supply the following items to install, initialize, and check the 2.4GZ OpenWay Gas Module on the meter.

- **Small and medium flat-blade or Phillips screwdrivers** Used to remove and tighten index and index-cover screws.
- **Side-cutting plier/wire snips** Used for cutting wire seals, if necessary.
- **Small putty knife** Used to remove all traces of old gaskets from the meter.
- **Meter seals, wire seals, and seal press** Used to secure the meter from tampering, if necessary.
- **11/32-inch nut driver or other blunt tool** Used to securely seat new tamper plugs over screw holes.
- **Replacement screws** Used to mount 2.4GZ OpenWay Gas Module assembly to meter and index to module assembly backplates.

Replacement Screws

Replacement screws used in this procedure are shown below.

For mounting 2.4GZ OpenWay Gas Module assemblies on meters:

- Use 10 - 24 x 5/8-inch slotted, Fillister head screws.

For mounting indexes on 2.4GZ OpenWay Gas Module backplates:

- Use 6 - 32 x 5/8-inch slotted, round head screws.

Preinstallation Preparations

Before installing the 2.4GZ OpenWay Gas Module on a meter, verify that:

- All Itron gas modules are 2.4GZ OpenWay Gas Modules for your brand of gas meters.
- The model numbers of all meters on which the 2.4GZ OpenWay Gas Modules will be installed are included in the Meter Compatibility List.

Installing the 2.4GZ OpenWay Gas Module

There are four major steps to installing the 2.4GZ OpenWay Gas Module on a meter:

- Remove the index
- Assemble the 2.4GZ OpenWay Gas Module
- Program the 2.4GZ OpenWay Gas Module
- Attach the 2.4GZ OpenWay Gas Module to the meter.



NOTE Properly dispose of all unused screws, old index covers, gaskets, tamper seals, and other left-over materials. Do not leave any materials on customer premises.

Remove the Existing Index

The first major step when installing a 2.4GZ OpenWay Gas Module on a Sensus meter is to remove the existing index from the meter.

To Remove the Index

1. Remove any tamper seals from the meter.
2. Detach the index cover from the meter by removing the four screws holding it in place.

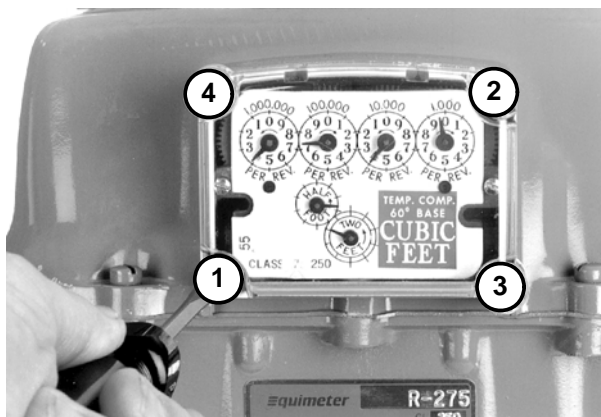

3. Examine the index cover screws you just removed. Verify that they are 5/8-inch long and are not corroded.
 - If the screws are 5/8-inch long and are not corroded, keep them for later use.
 - If they are an incorrect length or are corroded, dispose of them properly. Use 10 - 24 x 5/8-inch screws as described in [Replacement Screws](#) on page 25 instead.



TIP You can use the index cover you just removed as a temporary storage location for screws.

4. Unscrew one index mounting screw completely.

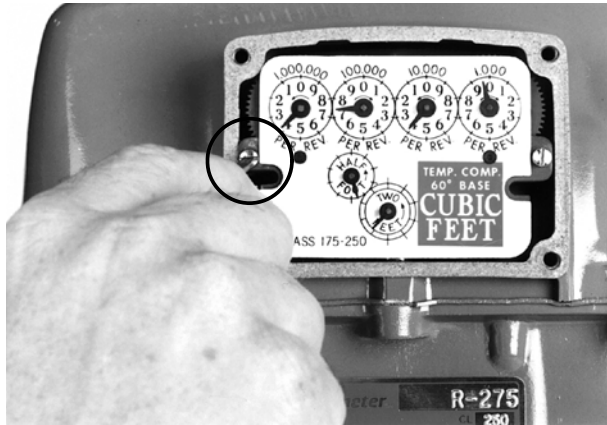

5. Remove the other index mounting screw.
6. Set the index aside for the moment. Place it where it will not be damaged; get filled with dirt, rain or snow; or fall to the ground or floor. The index will be used later in this procedure.
7. Examine the index screws you just removed. Verify that they are 5/8-inch long and are not corroded.
 - If the screws are 5/8-inch long and are not corroded, keep them for later use.
 - If the screws are an incorrect length or are corroded, dispose of them properly. Use 6 -32 x 5/8-inch screws as described in [Replacement Screws](#) on page 25 instead.

8. Use a putty knife or similar object to completely remove the old index gasket from the meter (if applicable). All traces of the gasket must be removed before the OpenWay Gas Module can be installed.

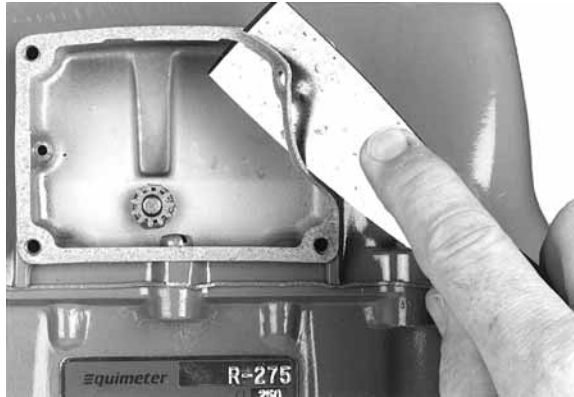

Assemble the OpenWay Gas Module

When installing a 2.4GZ OpenWay Gas Module, the next major step is to create the OpenWay Gas Module assembly by combining the module backplate and cover with the meter index. Follow the procedure below to do so.

To Assemble the OpenWay Gas Module

1. Obtain a new 2.4GZ OpenWay Gas Module.
2. Separate the OpenWay Gas Module backplate from the cover.
3. Place the index drive gear (1) in the backplate wiggler gear cup (2) of the OpenWay Gas Module (please note that the following example uses an 11-tooth drive gear; your index may have a 16- or 18-tooth drive gear, and you must use the appropriate 2.4GZ OpenWay Gas Module for your specific meter. See the [Meter Compatibility list](#) on page 2 for more information).

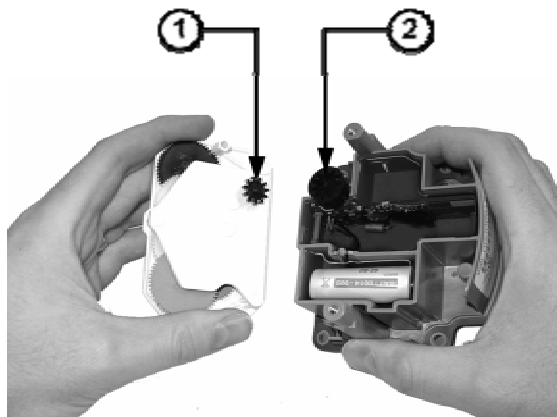

Once properly in place, the index drive gear and backplate wiggler cup should look similar to the following example.

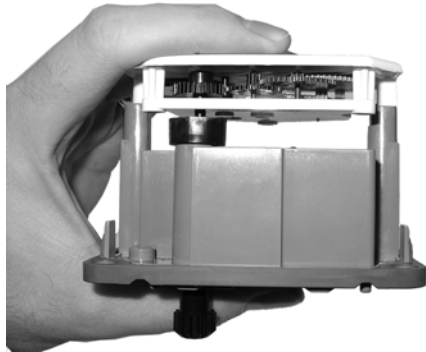

4. Attach the right-hand mounting screw to the index and meter, just far enough to hold the index in place. Use one 6 - 32 x 5/8-inch screw for this step (you can use an original mounting screw if it was the correct size and not corroded; otherwise, use the correct size [Replacement Screw](#) see "Replacement Screws" on page 25).



5. Install and tighten the left-hand index mounting screw.



6. Tighten the right-hand index mounting screw completely.

7. Slide the OpenWay Gas Module cover over the index and backplate.
8. Verify that the cover is installed correctly.



Once combined, the OpenWay Gas Module backplate, meter index, and OpenWay Gas Module cover create an OpenWay Gas Module Assembly.

Next, program the OpenWay Gas Module.

Program the OpenWay Gas Module

Once the OpenWay Gas Module has been assembled, the module must be programmed using FieldPro on a laptop with a ZigBee dongle. Refer to FieldPro documentation for programming information.



IMPORTANT You must perform the following programming procedure for the OpenWay Gas Module to function properly.

When programming the OpenWay Gas Module, you must take note of the drive rate shown on the index of Sensus meters. Sensus meters have a 2-foot drive rate, as indicated in the example below (1), or a 0.05 cubic metre drive (not shown).

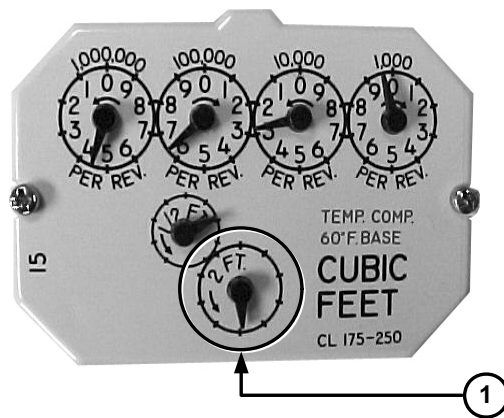

To Program the OpenWay Gas Module

NOTE Itron will be moving to this programming solution in early 2008

1. Using the FC200 and Belt Clip radio, program the reading of the index that was on the meter into the OpenWay Gas Module assembly.

During programming, the OpenWay Gas Module is programmed to the *nearest 100 cubic feet*; the last two digits (the tens and units) are programmed as zeros (0). Once programming is complete, however, the module assembly can be read to the nearest cubic foot.

2. Slowly turn the OpenWay Gas Module drive wiggler two turns in the direction indicated on the index drive rate. This lets you verify the module is counting properly after assembly.



IMPORTANT Do not turn the drive wiggler faster than *one turn per second*.

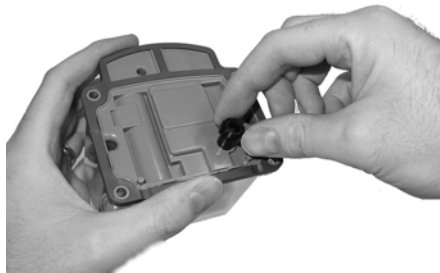

3. Read the OpenWay Gas Module assembly using the FC200 and Belt Clip radio. Consult the *EndPoint-Link Programming Guide* or other applicable instructions for details on how to read an OpenWay Gas Module.
 - If this reading is higher than the one you programmed in step 1 above, the ERT module assembly is counting correctly.
 - If the OpenWay Gas Module assembly reading is *not* higher than what was programmed in step 1, replace the module with a new one.

Attach the OpenWay Gas Module to the Meter

After the OpenWay Gas Module has been programmed and is reading correctly, follow the steps below to attach the module to the meter.

To Attach the OpenWay Gas Module to the Meter

1. Gently place the OpenWay Gas Module assembly against the front of the meter as shown. Make sure all four mounting screw holes in the 2.4GZ line up with the corresponding holes on the meter.



2. Insert the top-right cover mounting screw. Tighten the screw just enough to hold the 2.4GZ in place. Use the 10 - 24 x 5/8-inch screws for this and the following step (you can use the original mounting screws if they were the correct size and not corroded; otherwise, use the correct size as described in [Replacement Screws](#) on page 25).



3. Install and tighten the remaining three mounting screws. Tighten the mounting screws to 15 to 20 inch-pounds of torque.

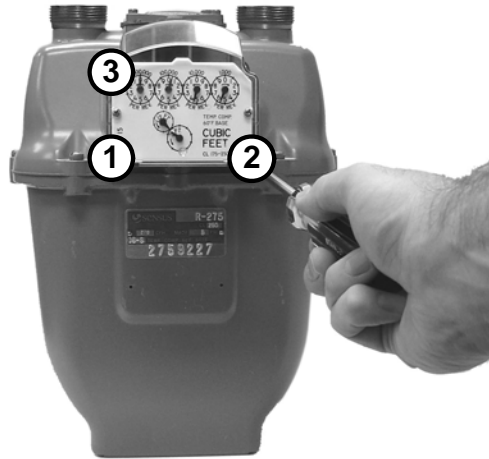

4. Tighten the top-right mounting screw.
5. Place a new tamper seal over two of the mounting screws as shown below.

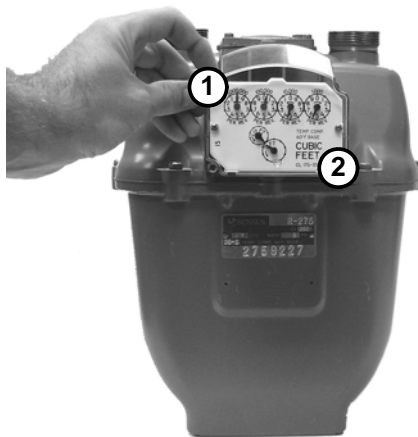

6. Press the new tamper seals into place using the 11/32-inch nut driver (or another similar blunt tool).

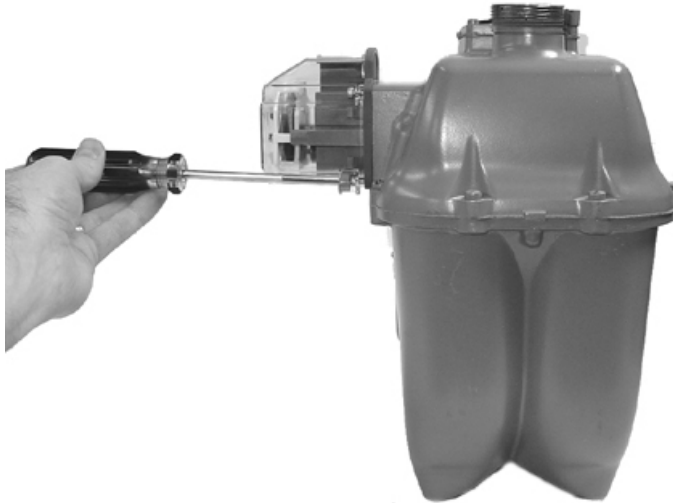

7. Complete any necessary paperwork. Make sure no excess material is left on the customer premises.

The OpenWay Gas Module is now installed on the meter.

