

TR-B12.EMv23M GAW, Engraving, Model #, Date code etching
 April 6, 2023 v1

B12 -Battery compartment
 Engraving: 0.3
 April 6, 2023 v1

TR-B12.EMv23M - buttons
 Silkscreen Print
 Feb 13, 2023

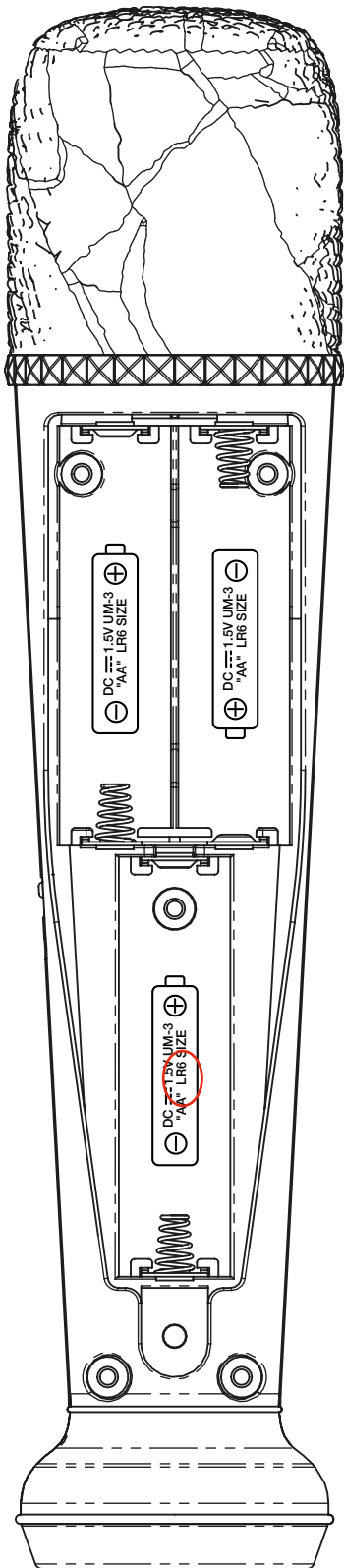
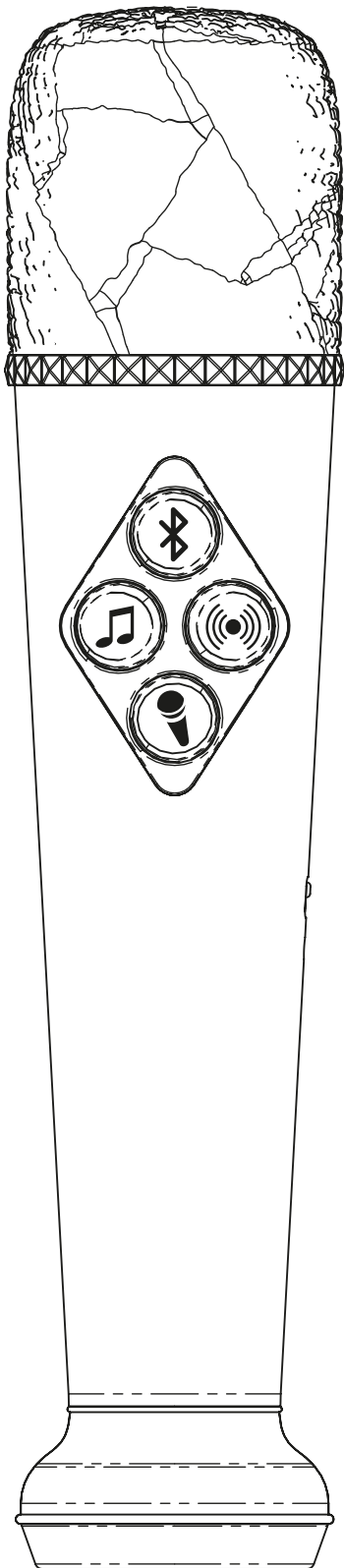
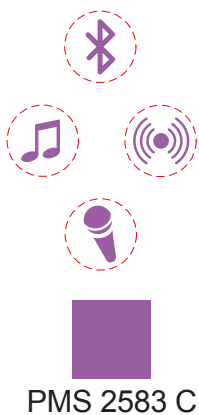

TR-B12.EMv23M

B12 -Battery door
 Engraving: 0.3
 April 6, 2023 v2

Feb 13, 2023
 Laser etching the
 model # and date code
 XXXXXX = six digits date code
 size: 7pt

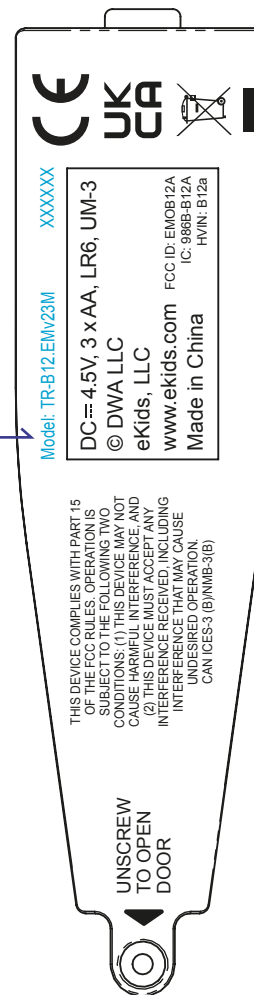

PROPERTY OF KIDDESIGNS

	1	2	3	4	5	6	7	8	9	10	11	12
2023												
2024												
2025												
2026												
2027												

XX-B12

B12 -front plastic
 Engraving: 0.3
 Jan 10, 2023

THIS DEVICE COMPLIES WITH PART 15
 OF THE FCC RULES. OPERATION IS
 SUBJECT TO THE FOLLOWING TWO
 CONDITIONS: (1) THIS DEVICE MUST
 NOT CAUSE HARMFUL INTERFERENCE
 AND (2) THIS DEVICE MUST ACCEPT ANY
 INTERFERENCE RECEIVED, INCLUDING
 INTERFERENCE THAT MAY CAUSE
 UNDESIRABLE OPERATION.
 CAN ICES-3 (B)/NMB-3(B)

UNSCREW
 TO OPEN
 DOOR