

Troubleshooting

If the unit does not respond:

- Make sure unit is completely charged.
- Use the extended wire of a paperclip or other thin tool to press in the Reset Button.
- To re-pair your device, press the Bluetooth Pairing Button on the back of the unit.

Note: The rechargeable battery can be replaced only by eKids Consumer Repair Department.

Maintenance

- It is important to keep the unit as dry and clean as possible. You may clean the cabinet with a cloth or sponge moistened with mild soap and water. Do not attempt to use strong cleansers or solvents, as they may cause damage.

FCC Information

FCC ID: EMO553N
IC: 986B-553N

This device complies with Part 15 of the FCC rules. Operation is subject to the following two conditions: (1) this device may not cause harmful interference, and (2) this device must accept any interference received, including interference that may cause undesired operation. This equipment complies with FCC radiation exposure limits set forth for an uncontrolled environment .

NOTE: This equipment has been tested and found to comply with the limits for a Class B digital device, pursuant to Part 15 of the FCC rules. These limits are designed to provide reasonable protection against harmful interference in a residential installation. This equipment generates, uses, and can radiate radio frequency energy and, if not installed and used in accordance with the instructions, may cause harmful interference to radio communications. However, there is no guarantee that interference will not occur in a particular installation. If this equipment does cause harmful interference to radio or television reception, which can be determined by turning the equipment off and on, the user is encouraged to try to correct the interference by one or more of the following measures:

- Reorient or relocate the receiving antenna.
- Increase the separation between the equipment and receiver.
- Connect the equipment into an outlet on a circuit different from that to which the receiver is connected.
- Consult the dealer or an experienced radio/TV technician for help.

WARNING: Changes or modifications to this unit not expressly approved by the party responsible for compliance could void the user's authority to operate the equipment.

CAN ICES-3 (B)/NMB-3(B)

Questions or Comments

- For questions or comments regarding this or other eKids products, please call our toll-free number: **1-888-TOP-TOYS**. Also visit our website: www.ekids.com

If problems persist, please do not attempt to repair unit; see warranty for factory service.

Limited One-Year Warranty

eKids, LLC warrants this product to be free from defects in workmanship and materials, under normal use and conditions, for a period of one (1) year from the date of original purchase.

Should this product fail to function in a satisfactory manner, it is best to first return it to the store where it was originally purchased. Should this fail to resolve the matter and service still be required by reason of any defect or malfunction during the warranty period, eKids will repair or, at its discretion, replace this product without charge. This decision is subject to verification of the defect or malfunction upon delivery of this product to the Factory Service Center authorized by Customer Service.

If service is required, please call Customer Service at 1-888-TOP-TOYS to obtain a Return Authorization Number and shipping instructions. A copy of the sales receipt is required to validate in-warranty coverage.

Disclaimer of Warranty

NOTE: This warranty is valid only if the product is used for the purpose for which it was designed. It does not cover (i) products which have been damaged by negligence or willful actions, misuse or accident, or which have been modified or repaired by unauthorized persons; (ii) cracked or broken cabinets, or units damaged by excessive heat; (iii) damage to digital media players, CD's or tape cassettes (if applicable); (iv) the cost of shipping this product to the Factory Service Center and its return to the owner.

This warranty is valid only in the United States of America and does not extend to owners of the product other than to the original purchaser. In no event will eKids or any of its affiliates, contractors, resellers, their officers, directors, shareholders, members or agents be liable to you or any third party for any consequential or incidental damages, any lost profits, actual, exemplary or punitive damages. (Some states do not allow limitations on implied warranties or exclusion of consequential damages, so these restrictions may not apply to you.) This warranty gives you specific legal rights, and you may also have other rights which vary from state to state.

Your acknowledgment and agreement to fully and completely abide by the above mentioned disclaimer of warranty is contractually binding to you upon your transfer of currency (money order, cashier's check, or credit card) for purchase of your eKids products.

© 2019 eKids, LLC
Questions? Visit www.ekids.com
or call 1-888-TOP-TOYS
1299 Main Street Rahway NJ 07065



Model: FR-553/TR-553

Bluetooth MP3 Karaoke with 2 Microphones

RF Exposure

This equipment complies with FCC radiation exposure limits set forth for an uncontrolled environment. This transmitter must not be co-located or operating in conjunction with any other antenna or transmitter.

**CHARGE
BEFORE
USE**

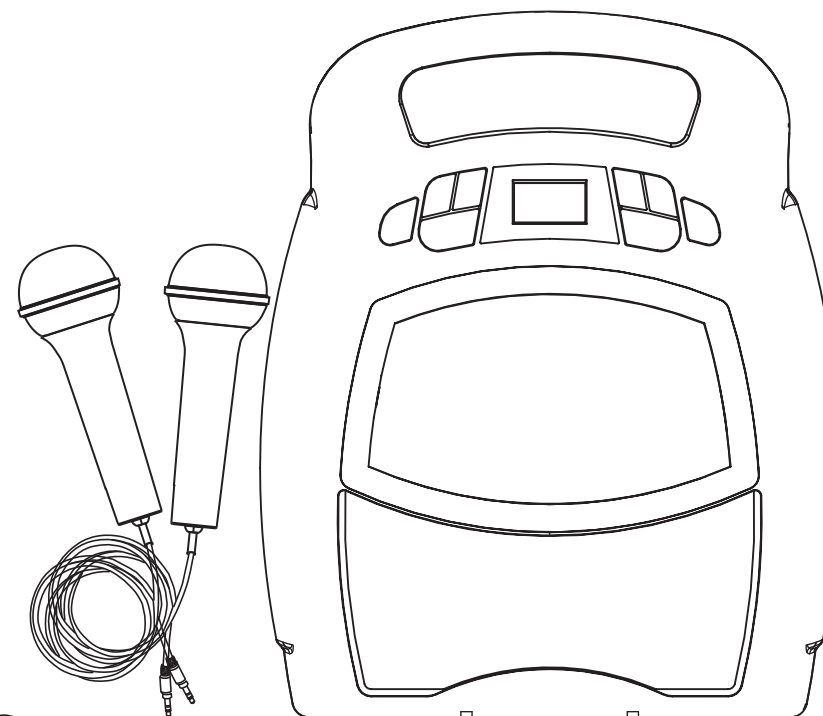

Important Message to Customers

Thank you for purchasing one of our top-quality electronic products. Please take a moment to read through these instructions to help you understand the safe and proper way to use this toy to extend its usability.

Keep these instructions for future reference as they contain important information.

Getting Started

There are three ways to listen to music with this unit:

- In USB Mode you can connect a flash drive to the unit and listen to your stored songs.
- In MP3 Mode you can transfer music from your computer to the unit via the micro USB Data Transfer port. The music will save to internal memory and you can listen to it directly from the unit itself.
- In Bluetooth Mode you can stream music from your smartphone or other Bluetooth device.

Note: When using USB Mode or Internal Memory Mode, this unit is compatible with .mp3 and .wav files ONLY.

This unit ships in Demo Mode for in-store demonstration purposes. Slide the Mode Switch to USB, MP3, or Bluetooth Mode to exit Demo Mode.

Charging The Unit

1. Connect the included micro USB cord to the micro USB charging port on the back of the unit.
2. Connect the standard USB plug end of the cord to a power USB port on a computer or other USB charging device. For first time use, charge unit for about 5 hours.

Charge via USB AC adaptor, computer USB port, or other powered USB port

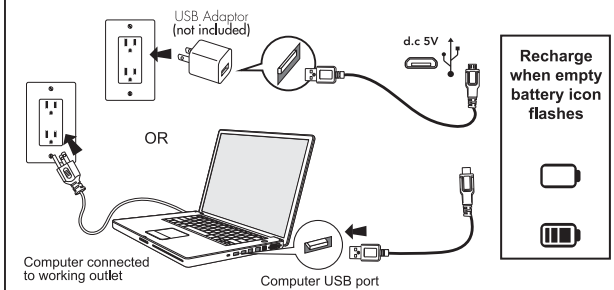

Using USB Mode

Make sure the Mode Switch is set to USB.

- When the unit is OFF, connect a USB flash drive to the USB port on the back of the unit.
- Press the Power Button to turn the unit ON. The "USB" icon will show on the top left of the display.
- When a USB drive is detected, the number of files on the USB drive will appear on the LCD display.
- Press Play, then use the "Forward" and "Reverse" buttons to advance through the numbers of files on the USB drive.
- Pressing "Play" will change the display to show a countdown time of the selected song file. After pressing "Play", the automatic play-all function will activate, and songs will play in the order they were stored. Press again to pause.

DISPLAY ICONS

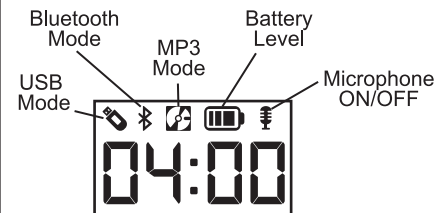

BACK OF UNIT

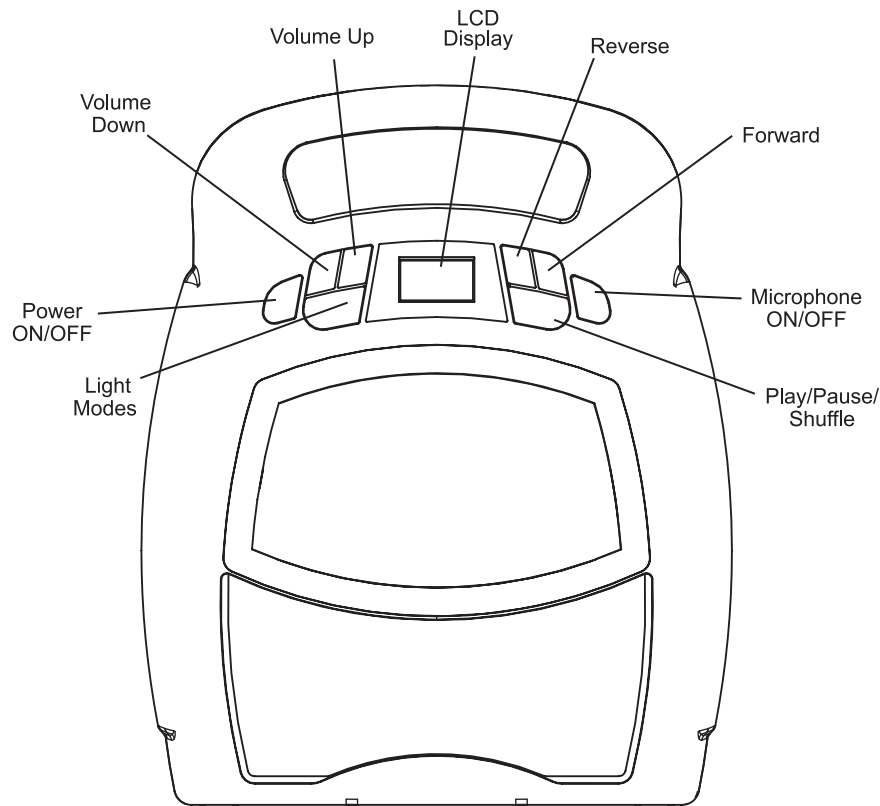
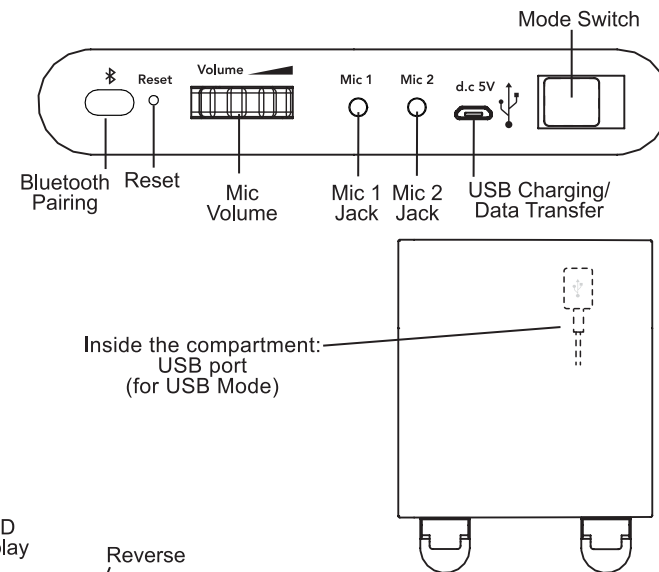

USING THE MICROPHONES

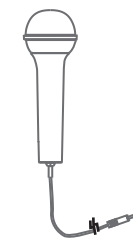

- Connect the microphones to Mic Jack 1 + 2 on the back of the unit.
- Press the Microphone ON/OFF button on the front of the unit.
- Control mic volume using the rotary dial on the back of the unit.

Using MP3 Mode

Make sure the Mode Switch is set to MP3 Mode and your USB flash drive is disconnected from the unit.

Storing Songs:

- Turn the unit ON, connect the micro USB cord to the Data Transfer port on the back of the unit. Connect the other end to a USB port on your computer.
- The unit should show up on your PC or Mac as a 'drive' or 'device'.
- Locate your music files on your PC or Mac (typically in the 'My Music' folder). **Note:** on some computers, your music files may be located elsewhere. Check your user manual for details.
- Select your desired songs (**.mp3 and .wav files are compatible**) and drag them onto the connected drive. When you are finished transferring files, 'eject' the device from your computer and disconnect the USB from the unit.

Playing Songs:

- The LCD display on the unit will show the number of songs stored. (ex: 100 songs would appear as "01:00").
- Use the "Forward" and "Reverse" buttons to advance through the numbers of files stored on the unit.
- After pressing "Play", the automatic play-all function will activate, and songs will play in the order they were stored.

Using Play/Pause/Shuffle

Press and hold to shuffle songs while playing music in USB Mode or MP3 Mode. 'SHU on' will flash on the display. Press and hold to disable shuffle. 'SHU off' will flash on the display.

Converting Files to MP3

iTunes music files are saved by default in .m4a format, and must be converted to .mp3 format to play on the unit in MP3 mode. Check the Help section in iTunes (or other music software program) to learn how to convert to .mp3 format.

Using Bluetooth Mode

- Select the "Bluetooth" position on the Mode Switch. The Bluetooth Mode icon will appear and 'bt' will flash on the LCD display while in pairing mode. Turn on your Bluetooth device and make it "discoverable" by turning on Bluetooth mode (check in Options or Settings).
- "BT-553" should appear in your device's Bluetooth menu. If "Not Connected" or a similar message appears, select "BT-553" to connect it.
- A voice prompt will confirm once your device is paired. Put your Bluetooth device in play mode to begin streaming music.
- Use the "Forward" "Reverse" and "Play/Pause" buttons on the unit to navigate tracks.
- Pairing automatically occurs in Bluetooth mode. Press the Bluetooth Pairing button on the back of the unit to re-pair.