

**ELECTROMAGNETIC EMISSIONS COMPLIANCE REPORT
INTENTIONAL RADIATOR CERTIFICATION TO
FCC PART 15 SUBPART C REQUIREMENT**

OF

Bluetooth MP3 Karaoke Player with Microphone

Model No.: DG-553, FR-553, XX-553 (X means A-Z, denote as color of the cabinet)

Trademark: KIDdesign, eKid

FCC ID: EMO553

Report No.: ES190221134E02

Issue Date: April 01, 2019

Prepared for

**SDI Technologies Inc.
1299, Main Street, Rahway, NJ 07065, U.S.A.**

Prepared by

EMTEK(SHENZHEN) CO., LTD.

**Bldg 69, Majialong Industry Zone, Nanshan District, Shenzhen,
Guangdong, China.**

TEL: 86-755-26954280

FAX: 86-755-26954282

**This report shall not be reproduced, except in full, without the written approval of
EMTEK(SHENZHEN) CO., LTD.**

VERIFICATION OF COMPLIANCE

Applicant:	SDI Technologies Inc. 1299, Main Street, Rahway, NJ 07065, U.S.A.
Manufacturer:	SDI Technologies Inc. 1299, Main Street, Rahway, NJ 07065, U.S.A.
Factory:	Harmonic Technology Co., Ltd. No. 8, Tianxin Street, Chung Kou Village, Shijie Town, Dongguan City, Guangdong Province.
Product Description:	Bluetooth MP3 Karaoke Player with Microphone
Trade Mark:	KIDdesign, eKid
Model Number:	DG-553, FR-553, XX-553 (X means A-Z, denote as color of the cabinet) (note: The models are the same except color of appearance and model number, here we prepare DG-553 for the full test)

We hereby certify that:

The above equipment was tested by EMTEK(SHENZHEN) CO., LTD. The test data, data evaluation, test procedures, and equipment configurations shown in this report were made in accordance with the procedures given in ANSI C63.10-2013 and the energy emitted by the sample EUT tested as described in this report is in compliance with conducted and radiated emission limits of FCC Rules Part 15.247(2018).

Date of Test : February 19, 2019 to March 18, 2019

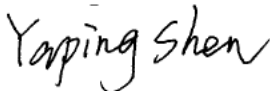
Prepared/Tested by : 
Yaping Shen/Editor

Reviewer : 
Joe Xia/Supervisor

Approved & Authorized Signer : 
Lisa Wang/Manager

Modified Information

Version	Summary	Revision Date	Report No.
Ver.1.0	Original Report	/	ES190221134E02

Table of Contents

1.	GENERAL INFORMATION.....	6
1.1	PRODUCT DESCRIPTION	6
1.2	TEST METHODOLOGY.....	6
1.3	TEST FACILITY	7
2.	SYSTEM TEST CONFIGURATION.....	8
2.1	EUT CONFIGURATION	8
2.2	EUT EXERCISE.....	8
2.3	TEST PROCEDURE.....	8
2.4	CONFIGURATION OF TESTED SYSTEM	9
2.5	RECEIVER INPUT BANDWIDTH.....	9
2.6	EXAMPLE OF A HOPPING SEQUENCE IN DATA MODE	10
2.7	EQUALLY AVERAGE USE OF FREQUENCIES AND BEHAVIOUR.....	10
3.	SUMMARY OF TEST RESULTS	11
4.	DESCRIPTION OF TEST MODES.....	12
5.	TEST SYSTEM UNCERTAINTY	13
6.	CONDUCTED EMISSIONS TEST	14
6.1	MEASUREMENT PROCEDURE:	14
6.2	TEST SET-UP (BLOCK DIAGRAM OF CONFIGURATION).....	14
6.3	MEASUREMENT EQUIPMENT USED:	14
6.4	MEASUREMENT RESULT:.....	15
6.5	CONDUCTED MEASUREMENT PHOTOS:	18
7.	RADIATED EMISSION TEST	19
7.1	MEASUREMENT PROCEDURE.....	19
7.2	TEST SET-UP (BLOCK DIAGRAM OF CONFIGURATION).....	21
7.3	MEASUREMENT EQUIPMENT USED:.....	22
7.4	RADIATED EMISSION LIMIT	23
7.5	MEASUREMENT RESULT	24
7.6	RADIATED MEASUREMENT PHOTOS:	32
8.	CHANNEL SEPARATION TEST	33
8.1	MEASUREMENT PROCEDURE.....	33
8.2	TEST SET-UP (BLOCK DIAGRAM OF CONFIGURATION).....	33
8.3	MEASUREMENT EQUIPMENT USED:.....	33
8.4	MEASUREMENT RESULTS:	33
9.	20DB BANDWIDTH TEST	40
9.1	MEASUREMENT PROCEDURE.....	40
9.2	TEST SET-UP (BLOCK DIAGRAM OF CONFIGURATION).....	40

9.3 MEASUREMENT EQUIPMENT USED:.....	40
9.4 MEASUREMENT RESULTS:.....	40
10. QUANTITY OF HOPPING CHANNEL TEST.....	47
10.1 MEASUREMENT PROCEDURE.....	47
10.2 TEST SET-UP (BLOCK DIAGRAM OF CONFIGURATION).....	47
10.3 MEASUREMENT EQUIPMENT USED:.....	47
10.4 MEASUREMENT RESULTS:	47
11. TIME OF OCCUPANCY (DWELL TIME) TEST.....	48
11.1 TEST DESCRIPTION.....	48
11.2 TEST SET-UP (BLOCK DIAGRAM OF CONFIGURATION).....	48
11.3 MEASUREMENT EQUIPMENT USED:.....	48
11.4 TEST REQUIREMENTS / LIMITS.....	48
11.5 TEST RESULT	49
12. MAXIMUM PEAK OUTPUT POWER TEST.....	51
12.1 MEASUREMENT PROCEDURE.....	51
12.2 TEST SET-UP (BLOCK DIAGRAM OF CONFIGURATION).....	51
12.3 MEASUREMENT EQUIPMENT USED:.....	51
12.4 MEASUREMENT RESULTS:.....	52
13. BAND EDGE TEST	58
13.1 MEASUREMENT PROCEDURE.....	58
13.2 TEST SET-UP (BLOCK DIAGRAM OF CONFIGURATION).....	59
13.3 MEASUREMENT EQUIPMENT USED:.....	59
13.4 MEASUREMENT RESULTS:	60
14. ANTENNA APPLICATION.....	76
14.1 ANTENNA REQUIREMENT	76
14.2 RESULT.....	76
15. PHOTOS OF EUT	76

1. GENERAL INFORMATION

1.1 Product Description

Characteristics	Description
Product Name	Bluetooth MP3 Karaoke Player with Microphone
Model number	DG-553
Input rating	DC 5V from adapter
Power Supply	AC 120V/60Hz for adapter
Kind of Device	Bluetooth Ver.4.2
Modulation	GFSK, $\pi/4$ -DQPSK, 8DPSK
Operating Frequency Range	2402-2480MHz
Number of Channels	79
Transmit Power Max(PK)	4.48dBm(0.002805W)
Antenna Type	Internal PCB antenna
Antenna Gain	0 dBi
Radio Software Version	V1.0
Radio Hardware version	V1.0

1.2 Test Methodology

Both conducted and radiated testing was performed according to the procedures in ANSI C63.10-2013. Radiated testing was performed at an antenna to EUT distance 3 meters.

1.3 Test Facility

Site Description

EMC Lab. : Accredited by CNAS, 2016.10.24
The certificate is valid until 2022.10.28
The Laboratory has been assessed and proved to be in compliance with CNAS-CL01:2006 (identical to ISO/IEC 17025:2005)
The Certificate Registration Number is L2291.

Accredited by TUV Rheinland Shenzhen 2016.5.19
The Laboratory has been assessed according to the requirements ISO/IEC 17025.

Accredited by FCC, August 03, 2017
Designation Number: CN1204
Test Firm Registration Number: 882943

Wireless Device Testing laboratories recognized by Innovation, Science and Economic Development Canada , 2018.09.12
The CAB identifier is CN0008.

Accredited by A2LA, July 31, 2017
The Certificate Number is 4321.01.

Name of Firm : EMTEK(SHENZHEN) CO., LTD.

Site Location : Bldg 69, Majialong Industry Zone, Nanshan District, Shenzhen, Guangdong, China.

2. System Test Configuration

2.1 EUT Configuration

The EUT configuration for testing is installed on RF field strength measurement to meet the Commissions requirement and operating in a manner which intends to maximize its emission characteristics in a continuous normal application.

2.2 EUT Exercise

The Transmitter was operated in the normal operating mode. The Tx frequency was fixed which was for the purpose of the measurements.

2.3 Test Procedure

2.3.1 Conducted Emissions

The EUT is placed on a turn table which is 0.8 m above ground plane. According to the requirements in Section 13.1.4.1 of ANSI C63.10-2013. Conducted emissions from the EUT measured in the frequency range between 0.15 MHz and 30MHz using CISPR Quasi-Peak and average detector mode.

2.3.2 Radiated Emissions

Below 1000MHz, The EUT was placed on a turn table which is 0.8m above ground plane. And above 1000MHz, The EUT was placed on a styrofoam table which is 1.5m above ground plane. The turn table shall rotate 360 degrees to determine the position of maximum emission level. EUT is set 3m away from the receiving antenna which varied from 1m to 4m to find out the highest emission. And also, each emission was to be maximized by changing the polarization of receiving antenna both horizontal and vertical. In order to find out the max. emission, the relative positions of EUT was fixed in a particular direction according to the requirements in Section 13.1.4.1 of ANSI C63.10-2013.

2.4 Configuration of Tested System

Fig. 2-1 Configuration of Tested System

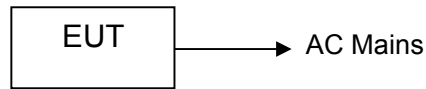

Table 2-1 Equipment Used in Tested System

Item	Equipment	Trademark	Model No.	FCC ID	Note
1.	Bluetooth MP3 Karaoke Player with Microphone	KIDdesign, eKid	DG-553	EMO553	<i>EUT</i>
2	Adapter	N/A	YSV6-0501000	N/A	<i>Support Equipment</i>

Note:

- (1) Unless otherwise denoted as EUT in 『Remark』 column , device(s) used in tested system is a support equipment.

2.5 Receiver Input Bandwidth

The input bandwidth of the receiver is 1.3MHZ, In every connection one Bluetooth device is the master and the other one is slave.The master determines the hopping sequence. The slave follows this sequence. Both devices shift between RX and and TX time slot according to the clock of the master. Additionally the type of connection(e.g. single of multislot packet)is set up at the beginning of the connection. The master adapts its hopping frequency and its TX/RX timing according to the packet type of the connection. Also the slave of the connection will use these settings .Repeating of a packet has no influence on the hopping sequence. The hopping sequence generated by the master of the connection will be followed in any case. That means, a repeated packet wil lnot be send on the same frequency, it is send on the next frequency of the hopping sequence.

2.6 Example of a Hopping Sequence in Data Mode

Example of a 79 hopping sequence in data mode:
40,21,44,23,42,53,46,55,48,33,52,35,50,65,54,67
56,37,60,39,58,69,62,71,64,25,68,27,66,57,70,59
72,29,76,31,74,61,78,63,01,41,05,43,03,73,07,75
09,45,13,47,11,77,15,00,64,49,66,53,68,02,70,06
01,51,03,55,05,04

2.7 Equally Average Use of Frequencies and Behaviour

The generation of the hopping sequence in connection mode depends essentially on two input values:

1. LAP/UAP of the master of the connection.
2. Internal master clock

The LAP(lower address part) are the 24 LSB's of the 48 BD_ADDRESS.

The BD_ADDRESS is an unambiguous number of every Bluetooth unit. The UAP(upper address part) are the 24MSB's of the 48 BD_ADDRESS .

The internal clock of a Bluetooth unit is derived from a free running clock which is never adjusted and is never turned off. For ehavior zation with other units only offset are used. It has no relation to the time of the day. Its resolution is at least half the RX/TX slot length of 312 .5us.The clock has a cycle of about one day (23h30) In most case it is implemented as 28 bit counter For the deriving of the hopping sequence the entire. LAP(24 bits), 4LSB's(4bits)(Input 1)and the 27MSB's of the clock(Input 2) are used. With this input values different mathematical procedures(permutations, additions, XOR-operations)are performed to generate te Sequence. This will be done at the beginning of every new transmission.

Regarding short transmissions the Bluetooth system has the following behavior:

The first connection between the two devices is established, a hopping sequence was generated. For Transmitting the wanted data the complete hopping sequence was not used. The connection ended.The second connection will be established. A new hopping sequence is generated.

Due to the fact the Bluetooth clock has a different value, because the period between the two transmission is longer(and it Cannot be shorter) than the minimum resolution of the clock (312 .5us). The hopping sequence will always Differ from the first one

3. Summary of Test Results

FCC Rules	Description Of Test	Result
§15.207	AC Power Conducted Emission	Compliant
§15.247(d),§15.209	Radiated Emission	Compliant
§15.247(a)(1)	Channel Separation test	Compliant
§15.247(a)(1)	20dB Bandwidth	Compliant
§15.247(a)(1)(iii)	Quantity of Hopping Channel	Compliant
§15.247(a)(1)(iii)	Time of Occupancy(Dwell Time)	Compliant
§15.247(b)	Max Peak output Power test	Compliant
§15.247(d)	Band edge test	Compliant
§15.203	Antenna Requirement	Compliant

4. Description of test modes

The EUT has been tested under its typical operating condition for EUT tested alone. Pre-defined engineering program for regulatory testing used to control the EUT for staying in continuous transmitting. Only the worst case data were reported.

The EUT has been associated with peripherals pursuant to ANSI C63.10-2013 and configuration operated in a manner tended to maximize its emission characteristics in a typical application. Frequency range investigated: radiation (9 KHz to the 10th harmonics of the highest fundamental frequency or to 40 GHz, whichever is lower).

For Radiated: The EUT's antenna was pre-tested under the following modes:

Test Mode	Description
Mode A	X-Y axis
Mode B	Y-Z axis
Mode C	X-Z axis

From the above modes, the worst case was found in Mode A. Therefore only the test data of the mode was recorded in this report.

The EUT has been tested under TX operating condition.

This EUT is a FHSS system, were conducted to determine the final configuration from all possible combinations. We use software control the EUT, Let EUT hopping on and transmit with highest power, all the modes GFSK, $\pi/4$ -DQPSK, 8DPSK have been tested. 79 Channels are provided by EUT. The 3 channels of lower, medium and higher were chosen for test.

Channel	Frequency(MHz)
1	2402
40	2441
79	2480

5. TEST SYSTEM UNCERTAINTY

The following measurement uncertainty levels have been estimated for tests performed on the apparatus:

Parameter	Uncertainty
Radio Frequency	$\pm 1 \times 10^{-5}$
Maximum Peak Output Power Test	$\pm 1.0\text{dB}$
Conducted Emissions Test	$\pm 2.0\text{dB}$
Radiated Emission Test	$\pm 2.0\text{dB}$
Power Density	$\pm 2.0\text{dB}$
Occupied Bandwidth Test	$\pm 1.0\text{dB}$
Band Edge Test	$\pm 3\text{dB}$
All emission, radiated	$\pm 3\text{dB}$
Antenna Port Emission	$\pm 3\text{dB}$
Temperature	$\pm 0.5^\circ\text{C}$
Humidity	$\pm 3\%$

Remark: The coverage Factor (k=2), and measurement Uncertainty for a level of Confidence of 95%

6. Conducted Emissions Test

6.1 Measurement Procedure:

1. The EUT was placed on a table, which is 0.8m above ground plane.
2. Maximum procedure was performed on the six highest emissions to ensure EUT compliance.
3. Repeat above procedures until all frequency measured was complete.

6.2 Test SET-UP (Block Diagram of Configuration)

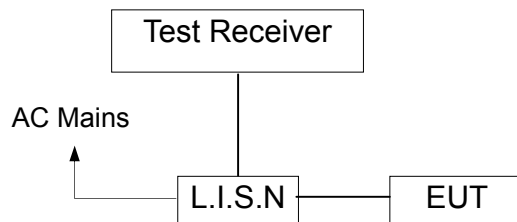

6.3 Measurement Equipment Used:

Conducted Emission Test Site						
EQUIPMENT TYPE	MFR	MODEL NUMBER	SERIAL NUMBER	Characteristics	Last Cal.	Due date
Test Receiver	Rohde & Schwarz	ESCS30	100018	9kHz~3GHz	05/16/2018	05/15/2019
L.I.S.N	Rohde & Schwarz	ENV216	100017	9KHz-300MHz	05/16/2018	05/15/2019
RF Switching Unit	CDS	RSU-M2	38401	9KHz-300MHz	05/16/2018	05/15/2019
Coaxial Cable	CDS	79254	46107086	9kHz~3GHz	05/16/2018	05/15/2019

6.4 Measurement Result:

Operation Mode:	TX	Test Date :	March 11, 2019
Frequency Range:	0.15MHz~30MHz	Temperature :	26°C
Test Result:	PASS	Humidity :	57 %
Test By:	Yaping Shen		

Pass.

Conducted emission at both 120V & 240V, and emission at 120V represents the worst case. All the modulation modes were tested the data of the worst mode (8DPSK TX 2402MHz) are recorded in the following pages and the others modulation methods do not exceed the limits.

Please refer to the following data.

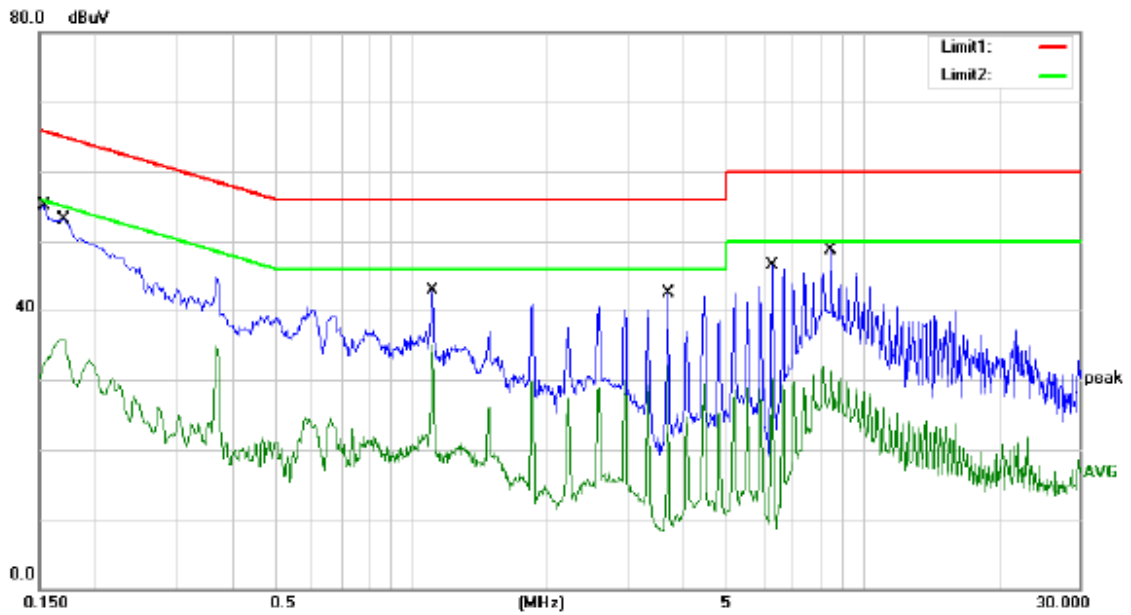

Site site #1 Phase: **L1** Temperature: 25
 Limit: (CE)FCC PART 15 C_QP Power: AC 120V/60Hz Humidity: 55 %
 Mode: TX2402
 Note:

No.	Mk.	Freq.	Reading Level	Correct Factor	Measurement	Limit	Over	Detector	Comment
		MHz	dBuV	dB	dBuV	dBuV	dB		
1	*	0.1540	45.18	10.01	55.19	65.78	-10.59	QP	
2		0.1540	22.69	10.01	32.70	55.78	-23.08	AVG	
3		0.1700	43.13	10.02	53.15	64.96	-11.81	QP	
4		0.1700	25.95	10.02	35.97	54.96	-18.99	AVG	
5		1.1140	32.71	10.18	42.89	56.00	-13.11	QP	
6		1.1140	25.02	10.18	35.20	46.00	-10.80	AVG	
7		3.7020	32.33	10.18	42.51	56.00	-13.49	QP	
8		3.7020	21.99	10.18	32.17	46.00	-13.83	AVG	
9		6.2820	36.28	10.19	46.47	60.00	-13.53	QP	
10		6.2820	19.85	10.19	30.04	50.00	-19.96	AVG	
11		8.4940	38.43	10.20	48.63	60.00	-11.37	QP	
12		8.4940	21.16	10.20	31.36	50.00	-18.64	AVG	

*:Maximum data x:Over limit !:over margin Comment: Factor build in receiver. Operator: Lin
 *:Maximum data x:Over limit !:over margin Comment: Factor build in receiver. Operator: Yaping shen

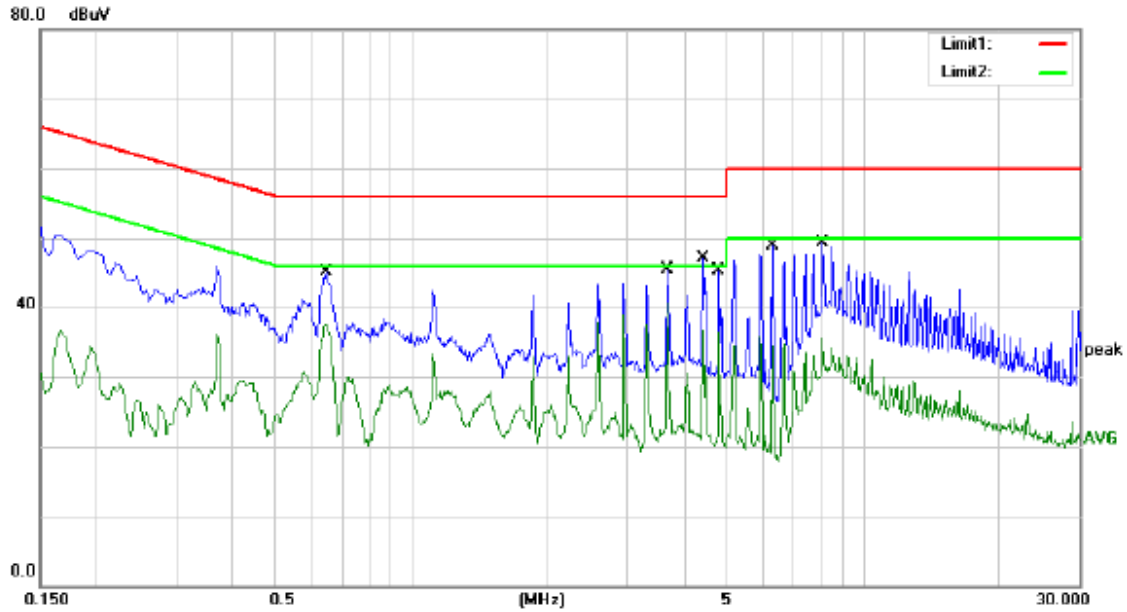

Site site #1 Phase: **N** Temperature: 25
 Limit: (CE)FCC PART 15 C_QP Power: AC 120V/60Hz Humidity: 55 %
 Mode: TX2402
 Note:

No.	Mk.	Freq.	Reading Level	Correct Factor	Measurement	Limit	Over	Detector	Comment
		MHz	dBuV	dB	dBuV	dBuV	dB		
1		0.6460	34.85	10.18	45.03	56.00	-10.97	QP	
2		0.6460	27.26	10.18	37.44	46.00	-8.56	AVG	
3		3.6780	35.41	10.18	45.59	56.00	-10.41	QP	
4	*	3.6780	30.57	10.18	40.75	46.00	-5.25	AVG	
5		4.4260	36.94	10.18	47.12	56.00	-8.88	QP	
6		4.4260	26.42	10.18	36.60	46.00	-9.40	AVG	
7		4.7860	35.22	10.18	45.40	56.00	-10.60	QP	
8		4.7860	26.25	10.18	36.43	46.00	-9.57	AVG	
9		6.2660	38.66	10.19	48.85	60.00	-11.15	QP	
10		6.2660	24.22	10.19	34.41	50.00	-15.59	AVG	
11		8.1220	39.02	10.20	49.22	60.00	-10.78	QP	
12		8.1220	25.29	10.20	35.49	50.00	-14.51	AVG	

*:Maximum data v:Over limit f:over margin Comment: Factor build in receiver. Operator: Lin
 *:Maximum data x:Over limit l:over margin Comment: Factor build in receiver. Operator: Yaping shen

6.5 Conducted Measurement Photos:



7. Radiated Emission Test

7.1 Measurement Procedure

1. The testing follows the guidelines in Spurious Radiated Emissions of ANSI C63.10-2013.
2. Below 1000MHz, The EUT was placed on a turn table which is 0.8m above ground plane. And above 1000MHz, The EUT was placed on a styrofoam table which is 1.5m above ground plane.
3. The EUT was set 3 meters from the interference receiving antenna, which was mounted on the top of a variable height antenna tower.
4. For each suspected emission, the EUT was arranged to its worst case and then tune the Antenna tower (From 1m to 4m) and turntable (from 0 degree to 360 degree) to find the maximum reading. A pre-amp and a high pass filter are used for the test in order to get better signal level to comply with the guidelines.
5. Set to the maximum power setting and enable the EUT transmit continuously.
6. Final measurement (Above 1GHz): The frequency range will be divided into different sub ranges depending of the frequency range of the used horn antenna. The EMI Receiver set to peak and average mode and a resolution bandwidth of 1MHz. The measurement will be performed in horizontal and vertical polarization of the measuring antenna and while rotating the EUT in its vertical axis in the range of 0 degree to 360 degree in order to have the antenna inside the cone of radiation.
7. Test Procedure of measurement (For Above 1GHz):
 - 1) Monitor the frequency range at horizontal polarization and move the antenna over all sides of the EUT(if necessary move the EUT to another orthogonal axis).
 - 2) Change the antenna polarization and repeat 1) with vertical polarization.
 - 3) Make a hardcopy of the spectrum.
 - 4) Measure the frequency of the detected emissions with a lower span and resolution bandwidth to increase the accuracy and note the frequency value.
 - 5) Change the analyser mode to Clear/ Write and found the cone of emission.
 - 6) Rotate and move the EUT, so that the measuring distance can be enlarged to 3m and the antenna will be still inside the cone of emission.
 - 7) Measure the level of the detected frequency with the correct resolution bandwidth, with the antenna polarization and azimuth and the peak and average detector, which causes the maximum emission.
 - 8) Repeat steps 1) to 7) for the next antenna spot if the EUT is larger than the antenna beamwidth.

Use the following spectrum analyzer settings:

When spectrum scanned from 30MHz to 1GHz setting resolution bandwidth 120KHz and video bandwidth 300KHz:

EMI Test Receiver	Setting
Attenuation	Auto
RB	120KHz
VB	300KHz
Detector	QP
Trace	Max hold

When spectrum scanned above 1GHz setting resolution bandwidth 1MHz, video bandwidth 3MHz:

EMI Test Receiver	Setting
Attenuation	Auto
RB	1MHz
VB	3MHz
Detector	Peak
Trace	Max hold

When spectrum scanned above 1GHz setting resolution bandwidth 1MHz, video bandwidth 10Hz:

EMI Test Receiver	Setting
Attenuation	Auto
RB	1MHz
VB	10Hz
Detector	Average
Trace	Max hold

7.2 Test SET-UP (Block Diagram of Configuration)

(A) Radiated Emission Test Set-Up, Frequency Below 30MHz

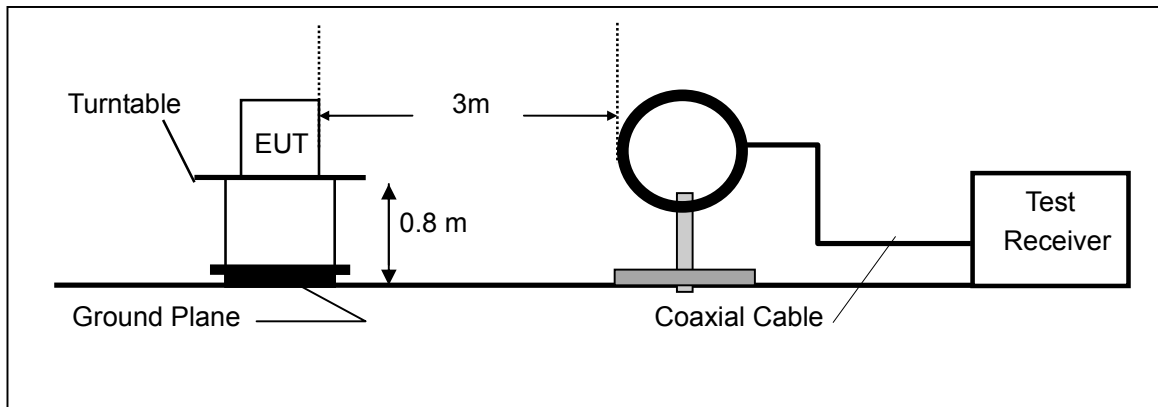

(B) Radiated Emission Test Set-Up, Frequency Below 1000MHz

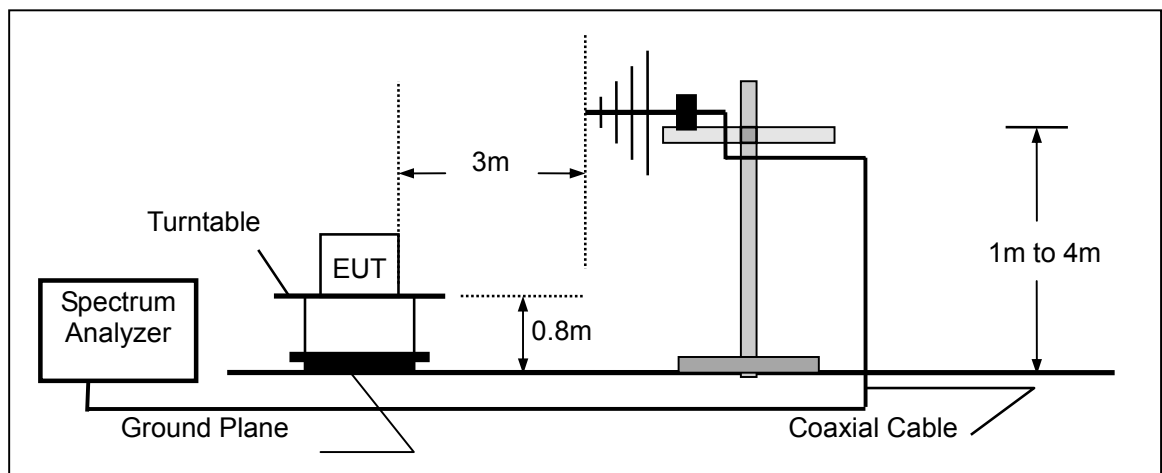

(C) Radiated Emission Test Set-Up, Frequency above 1000MHz

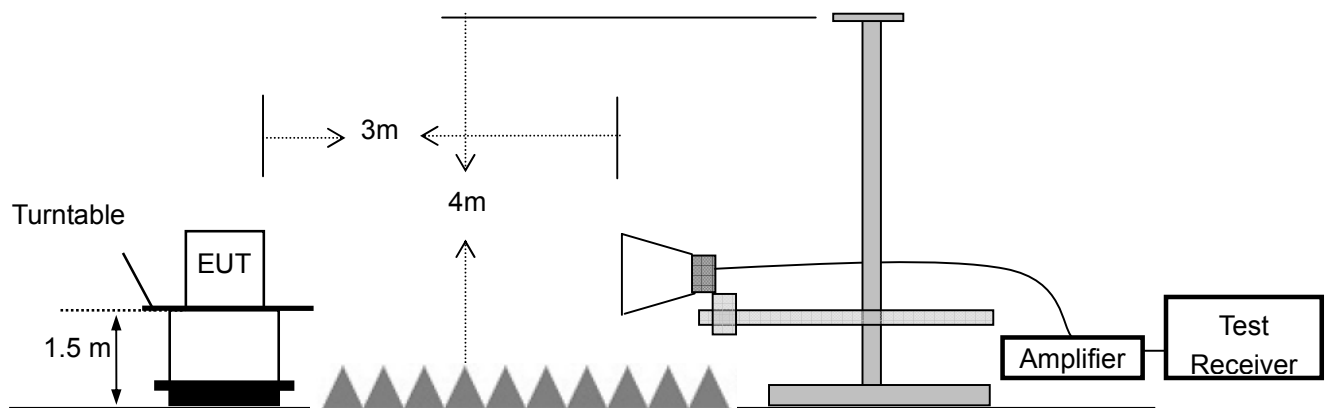

7.3 Measurement Equipment Used:

Item	Equipment	Manufacturer	Model No.	Serial No.	Characteristics	Last Cal.	Cal. Interval
1.	Test Receiver	Rohde & Schwarz	ESCI	1166.5950.03	9KHz-3GHz	05/16/2018	1 Year
2.	Loop Antenna	Schwarzbeck	FMZB 1519	012	9 KHz -30MHz	05/16/2018	1 Year
3.	Bilog Antenna	Schwarzbeck	VULB9163	000141	25MHz-2GHz	05/16/2018	1 Year
4.	Power Amplifier	CDS	RSU-M352	818	1MHz-1GHz	05/16/2018	1 Year
5.	Power Amplifier	HP	8447F	OPT H64	1GHz-26.5GHz	05/16/2018	1 Year
6.	Color Monitor	SUNSPO	SP-140A	N/A	--	05/16/2018	1 Year
7.	Single Line Filter	JIANLI	XL-3	N/A	--	05/16/2018	1 Year
8.	Single Phase Power Line Filter	JIANLI	DL-2X100B	N/A	--	05/16/2018	1 Year
9.	3 Phase Power Line Filter	JIANLI	DL-4X100B	N/A	--	05/16/2018	1 Year
10.	DC Power Filter	JIANLI	DL-2X50B	N/A	--	05/16/2018	1 Year
11.	Cable	Schwarzbeck	PLF-100	549489	9KHz-3GHz	05/16/2018	1 Year
12.	Cable	Rosenberger	CIL02	A0783566	9KHz-3GHz	05/16/2018	1 Year
13.	Cable	Rosenberger	RG 233/U	525178	9KHz-3GHz	05/16/2018	1 Year
14.	Signal Analyzer	Rohde & Schwarz	FSV30	103040	9KHz-40GHz	05/16/2018	1 Year
15.	Horn Antenna	Schwarzbeck	BBHA9120D	9120D-1272	1GHz-18GHz	05/16/2018	1 Year
16.	Horn Antenna	Schwarzbeck	BBHA 9170	BBHA9170399	14GHz-26.5GHz	05/16/2018	1 Year
17.	Power Amplifier	LUNAR EM	LNA1G18-40	J10100000081	1GHz-26.5GHz	05/16/2018	1 Year
18.	Cable	H+S	CBL-26	N/A	1GHz-26.5GHz	05/16/2018	1 Year
19.	Cable	H+S	CBL-26	N/A	1GHz-26.5GHz	05/16/2018	1 Year
20.	Cable	H+S	CBL-26	N/A	1GHz-26.5GHz	05/16/2018	1 Year

7.4 Radiated Emission Limit

The emissions from an intentional radiator shall not exceed the field strength levels specified in the following table 15.209(a):

Frequencies (MHz)	Field Strength (micровolts/meter)	Measurement Distance (meters)
0.009~0.490	2400/F(KHz)	300
0.490~1.705	24000/F(KHz)	30
1.705~30.0	30	30
30~88	100	3
88~216	150	3
216~960	200	3
Above 960	500	3

15.205 Restricted bands of operation

MHz	MHz	MHz	GHz
0.090 - 0.110	16.42 - 16.423	399.9 - 410	4.5 - 5.15
¹ 0.495 - 0.505	16.69475 - 16.69525	608 - 614	5.35 - 5.46
2.1735 - 2.1905	16.80425 - 16.80475	960 - 1240	7.25 - 7.75
4.125 - 4.128	25.5 - 25.67	1300 - 1427	8.025 - 8.5
4.17725 - 4.17775	37.5 - 38.25	1435 - 1626.5	9.0 - 9.2
4.20725 - 4.20775	73 - 74.6	1645.5 - 1646.5	9.3 - 9.5
6.215 - 6.218	74.8 - 75.2	1660 - 1710	10.6 - 12.7
6.26775 - 6.26825	108 - 121.94	1718.8 - 1722.2	13.25 - 13.4
6.31175 - 6.31225	123 - 138	2200 - 2300	14.47 - 14.5
8.291 - 8.294	149.9 - 150.05	2310 - 2390	15.35 - 16.2
8.362 - 8.366	156.52475 - 156.52525	2483.5 - 2500	17.7 - 21.4
8.37625 - 8.38675	156.7 - 156.9	2690 - 2900	22.01 - 23.12
8.41425 - 8.41475	162.0125 - 167.17	3260 - 3267	23.6 - 24.0
12.29 - 12.293	167.72 - 173.2	3332 - 3339	31.2 - 31.8
12.51975 - 12.52025	240 - 285	3345.8 - 3358	36.43 - 36.5
12.57675 - 12.57725	322 - 335.4	3600 - 4400	(²)

Remark 1. Emission level in dBuV/m=20 log (uV/m)

- :
- Measurement was performed at an antenna to the closed point of EUT distance of meters.
 - Only spurious frequency is permitted to locate within the Restricted Bands specified in provision of § 15.205, and the emissions located in restricted bands also comply with 15.209 limit.

7.5 Measurement Result

Operation Mode:	TX	Test Date :	March 17, 2019
Test By:	Yaping Shen	Temperature :	25°C
Test Result:	PASS	Humidity :	59 %
Measured Distance:	3m		

Below 30MHz:

Freq. (MHz)	Ant.Pol. H/V	Emission Level (dBuV/m)	Limit 3m (dBuV/m)	Over (dB)
--	--	--	--	--

Note: The low frequency, which started from 9KHz-30MHz, was pre-scanned and the result which was 20dB lower than the limit line per 15.31(o) was not reported.

Below 1000MHz:

Pass.

All the modulation modes were tested the data of the worst mode (8DPSK TX2441 MHz) are recorded in the following pages and the others modulation methods do not exceed the limits.

Please refer to the following data.

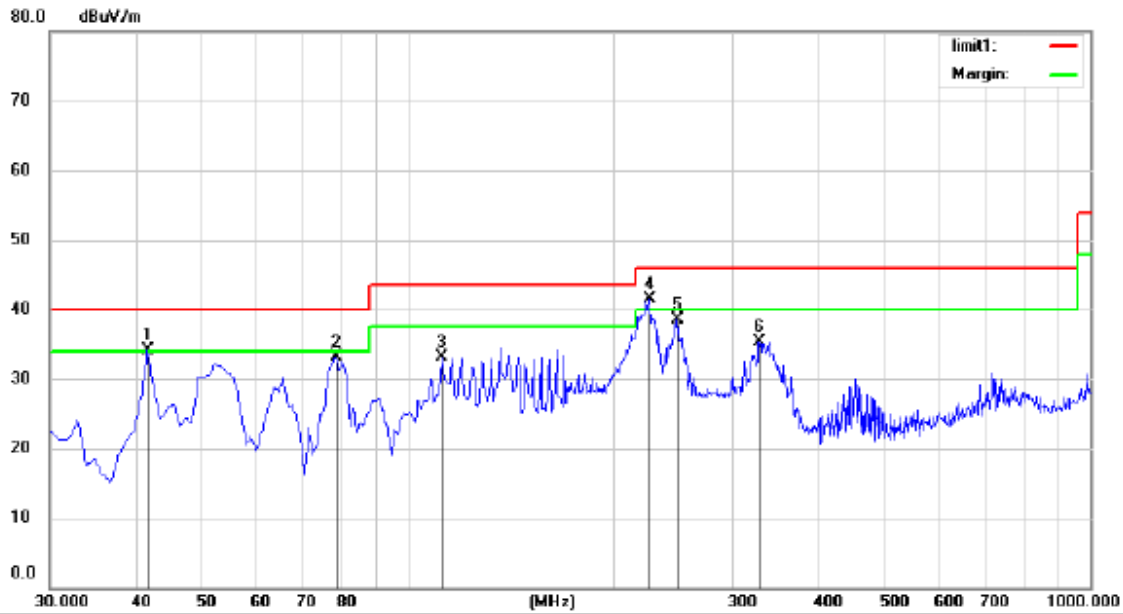

Site Chamber #1 Polarization: *Horizontal* Temperature: 28
 Limit: (RE)FCC PART 15 C 3m Power: Battery 3.7V Humidity: 55 %

Mode: TX2441

Note:

No.	Mk.	Freq.	Reading Level	Correct Factor	Measurement	Limit	Over	Antenna Height	Table Degree	
		MHz	dBuV	dB	dBuV/m	dBuV/m	dB	cm	degree	Comment
1	!	41.6400	50.31	-16.25	34.06	40.00	-5.94			QP
2		78.5000	54.54	-21.52	33.02	40.00	-6.98			QP
3		112.4500	51.92	-18.76	33.16	43.50	-10.34			QP
4	*	225.9400	58.12	-16.55	41.57	46.00	-4.43			QP
5		248.2500	54.07	-15.57	38.50	46.00	-7.50			QP
6		326.8200	48.39	-13.03	35.36	46.00	-10.64			QP

*:Maximum data x:Over limit !:over margin Comment: Factor build in receiver. Operator: Yaping shen

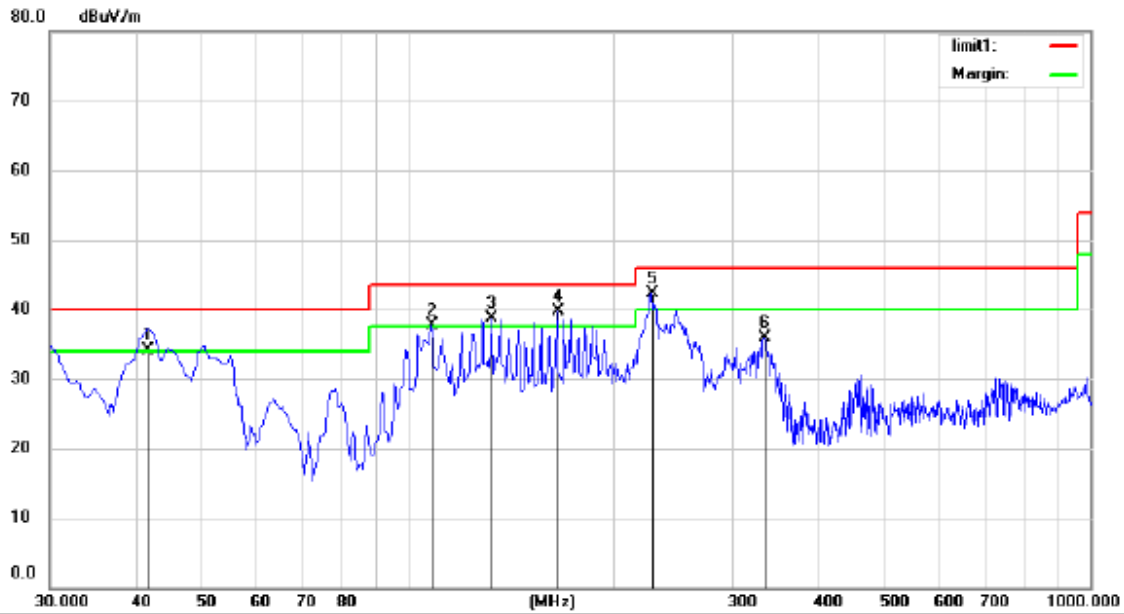

Site: Chamber #1 Polarization: **Vertical** Temperature: 26
 Limit: (RE)FCC PART 15 C 3m Power: Battery 3.7V Humidity: 55 %

Mode: TX2441
 Note:

No.	Mk.	Freq. MHz	Reading Level dBuV	Correct Factor dB	Measure- ment dBuV/m	Limit dBuV/m	Over dB	Antenna Height cm	Table Degree	Detector	Comment
1	!	41.6400	50.32	-16.25	34.07	40.00	-5.93			QP	
2	!	108.5700	56.67	-19.00	37.67	43.50	-5.83			QP	
3	!	132.8200	57.74	-19.04	38.70	43.50	-4.80			QP	
4	!	165.8000	59.93	-20.31	39.62	43.50	-3.88			QP	
5	*	227.8800	58.79	-16.45	42.34	46.00	-3.66			QP	
6		333.6100	49.44	-13.59	35.85	46.00	-10.15			QP	

! : Maximum data x : Over limit ! : over margin Comment: Factor build in receiver. Operator: Yaping shen

Above 1000MHz~10th Harmonics:

Please refer to the following data.

Operation Mode: GFSK (CH1: 2402MHz) Test Date : March 17, 2019

Freq. (MHz)	Ant. Pol. H/V	Reading Level(dBuV/m)		Correct Factor dB	Emission Level(dBuV/m)		Limit 3m(dBuV/m)		Margin(dB)	
		PK	AV		PK	AV	PK	AV	PK	AV
4804	V	96.08	75.57	-32.3	63.78	43.27	74	54	-10.22	-10.73
7206	V	97.81	78.28	-37.25	60.56	41.03	74	54	-13.44	-12.97
9608	V	99.01	79.94	-39.8	59.21	40.14	74	54	-14.79	-13.86
12010	V	96.19	77.25	-40.5	55.69	36.75	74	54	-18.31	-17.25
14412	V	97.03	78.09	-41.7	55.33	36.39	74	54	-18.67	-17.61
16814	V	95.11	76.08	-40	55.11	36.08	74	54	-18.89	-17.92
4804	H	94.82	74.98	-31.4	63.42	43.58	74	54	-10.58	-10.42
7206	H	95.96	76.81	-35.5	60.46	41.31	74	54	-13.54	-12.69
9608	H	97.48	78.53	-38.3	59.18	40.23	74	54	-14.82	-13.77
12010	H	95.45	76.69	-39	56.45	37.69	74	54	-17.55	-16.31
14412	H	97.34	78.28	-42	55.34	36.28	74	54	-18.66	-17.72
16814	H	94.57	75.34	-39.3	55.27	36.04	74	54	-18.73	-17.96

Operation Mode: GFSK (CH40: 2441MHz) Test Date : March 17, 2019

Freq. (MHz)	Ant. Pol. H/V	Reading Level(dBuV/m)		Correct Factor dB	Emission Level(dBuV/m)		Limit 3m(dBuV/m)		Margin(dB)	
		PK	AV		PK	AV	PK	AV	PK	AV
4882	V	95.87	76.28	-32.3	63.57	43.98	74	54	-10.43	-10.02
7323	V	97.79	78.07	-37.2	60.59	40.87	74	54	-13.41	-13.13
9764	V	99.03	79.39	-39.6	59.43	39.79	74	54	-14.57	-14.21
12205	V	99.16	80.06	-40.5	58.66	39.56	74	54	-15.34	-14.44
14646	V	97.31	78.42	-41	56.31	37.42	74	54	-17.69	-16.58
17087	V	96.85	77.63	-41.1	55.75	36.53	74	54	-18.25	-17.47
4882	H	94.97	74.82	-31.6	63.37	43.22	74	54	-10.63	-10.78
7323	H	96.32	76.53	-35.7	60.62	40.83	74	54	-13.38	-13.17
9764	H	96.62	76.91	-38.3	58.32	38.61	74	54	-15.68	-15.39
12205	H	95.37	75.82	-39	56.37	36.82	74	54	-17.63	-17.18
14646	H	97.362	77.58	-42	55.36	35.58	74	54	-18.64	-18.42
17087	H	96.78	76.85	-41.5	55.28	35.35	74	54	-18.72	-18.65

Operation Mode: GFSK (CH79: 2480MHz) Test Date : March 17, 2019

Freq. (MHz)	Ant. Pol. H/V	Reading Level(dBuV/m)		Correct Factor dB	Emission Level(dBuV/m)		Limit 3m(dBuV/m)		Margin(dB)	
		PK	AV		PK	AV	PK	AV	PK	AV
4960	V	95.19	75.92	-32.3	62.89	43.62	74	54	-11.11	-10.38
7440	V	98.76	79.03	-37.2	61.56	41.83	74	54	-12.44	-12.17
9920	V	99.27	79.58	-39.6	59.67	39.98	74	54	-14.33	-14.02
12400	V	98.04	78.54	-40.7	57.34	37.84	74	54	-16.66	-16.16
14880	V	97.58	77.65	-41	56.58	36.65	74	54	-17.42	-17.35
17360	V	96.46	77.51	-41.1	55.36	36.41	74	54	-18.64	-17.59
4960	H	94.35	74.83	-31.6	62.75	43.23	74	54	-11.25	-10.77
7440	H	96.94	77.78	-35.7	61.24	42.08	74	54	-12.76	-11.92
9920	H	97.66	78.57	-38.1	59.56	40.47	74	54	-14.44	-13.53
12400	H	96.69	77.52	-39	57.69	38.52	74	54	-16.31	-15.48
14880	H	98.33	79.61	-42	56.33	37.61	74	54	-17.67	-16.39
17360	H	96.73	78.06	-41.5	55.23	36.56	74	54	-18.77	-17.44

Operation Mode: Pi/4-DQPSK (CH1: 2402MHz) Test Date : March 17, 2019

Freq. (MHz)	Ant. Pol. H/V	Reading Level(dBuV/m)		Correct Factor dB	Emission Level(dBuV/m)		Limit 3m(dBuV/m)		Margin(dB)	
		PK	AV		PK	AV	PK	AV	PK	AV
4804	V	94.65	75.51	-32.3	62.35	43.21	74	54	-11.65	-10.79
7206	V	97.91	78.79	-37.2	60.71	41.59	74	54	-13.29	-12.41
9608	V	99.14	80.28	-39.8	59.34	40.48	74	54	-14.66	-13.52
12010	V	97.19	78.16	-40.5	56.69	37.66	74	54	-17.31	-16.34
14412	V	98.07	79.22	-41.7	56.37	37.52	74	54	-17.63	-16.48
16814	V	95.85	76.93	-40	55.85	36.93	74	54	-18.15	-17.07
4804	H	93.73	75.02	-31.6	62.13	43.42	74	54	-11.87	-10.58
7206	H	96.08	77.86	-35.5	60.58	42.36	74	54	-13.42	-11.64
9608	H	97.73	79.62	-38.3	59.43	41.32	74	54	-14.57	-12.68
12010	H	95.72	77.45	-39.4	56.32	38.05	74	54	-17.68	-15.95
14412	H	97.61	79.57	-42	55.61	37.57	74	54	-18.39	-16.43
16814	H	94.44	76.68	-39.3	55.14	37.38	74	54	-18.86	-16.62

Operation Mode: Pi/4-DQPSK (CH40: 2441MHz) Test Date : March 17, 2019

Freq. (MHz)	Ant. Pol.	Reading Level(dBuV/m)		Correct Factor dB	Emission Level(dBuV/m)		Limit 3m(dBuV/m)		Margin(dB)	
		PK	AV		PK	AV	PK	AV	PK	AV
4882	V	94.86	75.92	-32.3	62.56	43.62	74	54	-11.44	-10.38
7323	V	98.87	80.05	-37.2	61.67	42.85	74	54	-12.33	-11.15
9764	V	98.41	79.38	-39.8	58.61	39.58	74	54	-15.39	-14.42
12205	V	96.88	77.96	-40.5	56.38	37.46	74	54	-17.62	-16.54
14646	V	97.25	78.34	-41	56.25	37.34	74	54	-17.75	-16.66
17087	V	97.03	77.96	-41.1	55.93	36.86	74	54	-18.07	-17.14
4882	H	94.08	75.15	-31.6	62.48	43.55	74	54	-11.52	-10.45
7323	H	97.19	78.23	-35.5	61.69	42.73	74	54	-12.31	-11.27
9764	H	97.82	78.79	-38.3	59.52	40.49	74	54	-14.48	-13.51
12205	H	95.36	76.58	-39	56.36	37.58	74	54	-17.64	-16.42
14646	H	97.68	78.84	-42	55.68	36.84	74	54	-18.32	-17.16
17087	H	96.67	77.98	-41.4	55.27	36.58	74	54	-18.73	-17.42

Operation Mode: Pi/4-DQPSK (CH79: 2480MHz) Test Date : March 17, 2019

Freq. (MHz)	Ant. Pol.	Reading Level(dBuV/m)		Correct Factor dB	Emission Level(dBuV/m)		Limit 3m(dBuV/m)		Margin(dB)	
		PK	AV		PK	AV	PK	AV	PK	AV
4960	V	94.67	75.88	-32.3	62.37	43.58	74	54	-11.63	-10.42
7440	V	97.46	78.87	-37.2	60.26	41.67	74	54	-13.74	-12.33
9920	V	99.33	80.14	-39.8	59.53	40.34	74	54	-14.47	-13.66
12400	V	98.89	80.16	-40.5	58.39	39.66	74	54	-15.61	-14.34
14880	V	97.25	78.82	-41	56.25	37.82	74	54	-17.75	-16.18
17360	V	96.51	77.23	-41.1	55.41	36.13	74	54	-18.59	-17.87
4960	H	93.93	75.38	-31.6	62.33	43.78	74	54	-11.67	-10.22
7440	H	95.28	76.19	-35.5	59.78	40.69	74	54	-14.22	-13.31
9920	H	96.95	77.66	-38.3	58.65	39.36	74	54	-15.35	-14.64
12400	H	95.82	76.63	-39	56.82	37.63	74	54	-17.18	-16.37
14880	H	97.43	78.72	-42	55.43	36.72	74	54	-18.57	-17.28
17360	H	96.76	78.04	-41.5	55.26	36.54	74	54	-18.74	-17.46

Operation Mode: 8DPSK (CH1: 2402MHz) Test Date : March 17, 2019

Freq. (MHz)	Ant. Pol. H/V	Reading Level(dBuV/m)		Correct Factor dB	Emission Level(dBuV/m)		Limit 3m(dBuV/m)		Margin(dB)	
		PK	AV		PK	AV	PK	AV	PK	AV
4804	V	94.67	75.56	-32.3	62.37	43.26	74	54	-11.63	-10.7
7206	V	97.38	78.92	-37.2	60.18	41.72	74	54	-13.82	-12.3
9608	V	99.22	80.33	-39.8	59.42	40.53	74	54	-14.58	-13.5
12010	V	97.88	79.07	-40.5	57.38	38.57	74	54	-16.62	-15.4
14412	V	97.99	79.34	-41.7	56.29	37.64	74	54	-17.71	-16.4
16814	V	95.83	76.85	-40	55.83	36.85	74	54	-18.17	-17.2
4804	H	94.15	74.98	-31.6	62.55	43.38	74	54	-11.45	-10.6
7206	H	95.98	77.19	-35.5	60.48	41.69	74	54	-13.52	-12.3
9608	H	97.56	78.61	-38.3	59.26	40.31	74	54	-14.74	-13.7
12010	H	97.51	78.67	-39	58.51	39.67	74	54	-15.49	-14.3
14412	H	99.39	80.58	-42	57.39	38.58	74	54	-16.61	-15.4
16814	H	94.76	75.69	-39.3	55.46	36.39	74	54	-18.54	-17.6

Operation Mode: 8DPSK (CH40: 2441MHz) Test Date : March 17, 2019

Freq. (MHz)	Ant. Pol. H/V	Reading Level(dBuV/m)		Correct Factor dB	Emission Level(dBuV/m)		Limit 3m(dBuV/m)		Margin(dB)	
		PK	AV		PK	AV	PK	AV	PK	AV
4882	V	95.05	75.94	-32.3	62.75	43.64	74	54	-11.25	-10.36
7323	V	98.78	79.59	-37.2	61.58	42.39	74	54	-12.42	-11.61
9764	V	98.26	79.08	-39.8	58.46	39.28	74	54	-15.54	-14.72
12205	V	96.87	78.12	-40.5	56.37	37.62	74	54	-17.63	-16.38
14646	V	96.49	77.93	-41	55.49	36.93	74	54	-18.51	-17.07
17087	V	96.32	77.55	-41.1	55.22	36.45	74	54	-18.78	-17.55
4882	H	94.28	75.17	-31.6	62.68	43.57	74	54	-11.32	-10.43
7323	H	95.95	76.86	-35.5	60.45	41.36	74	54	-13.55	-12.64
9764	H	96.72	77.99	-38.3	58.42	39.69	74	54	-15.58	-14.31
12205	H	95.81	76.58	-39	56.81	37.58	74	54	-17.19	-16.42
14646	H	97.66	78.42	-42	55.66	36.42	74	54	-18.34	-17.58
17087	H	96.83	77.86	-41.5	55.33	36.36	74	54	-18.67	-17.64

Operation Mode: 8DPSK (CH79: 2480MHz) Test Date : March 17, 2019

Freq. (MHz)	Ant. Pol.	Reading Level(dBuV/m)		Correct Factor dB	Emission Level(dBuV/m)		Limit 3m(dBuV/m)		Margin(dB)	
		PK	AV		PK	AV	PK	AV	PK	AV
4960	V	94.68	75.57	-32.3	62.38	43.27	74	54	-11.62	-10.73
7440	V	98.42	78.56	-37.2	61.22	41.36	74	54	-12.78	-12.64
9920	V	99.36	80.01	-39.8	59.56	40.21	74	54	-14.44	-13.79
12400	V	96.89	78.32	-40.5	56.39	37.82	74	54	-17.61	-16.18
14880	V	96.37	77.63	-41	55.37	36.63	74	54	-18.63	-17.37
17360	V	96.34	77.29	-41.1	55.24	36.19	74	54	-18.76	-17.81
4960	H	94.07	74.95	-31.6	62.47	43.35	74	54	-11.53	-10.65
7440	H	96.08	77.23	-35.5	60.58	41.73	74	54	-13.42	-12.27
9920	H	97.72	78.62	-38.3	59.42	40.32	74	54	-14.58	-13.68
12400	H	95.76	76.51	-39	56.76	37.51	74	54	-17.24	-16.49
14880	H	97.61	78.75	-42	55.61	36.75	74	54	-18.39	-17.25
17360	H	96.87	77.66	-41.5	55.37	36.16	74	54	-18.63	-17.84

Other harmonics emissions are lower than 20dB below the allowable limit.

- Note:**
- (1) All Readings are Peak Value and AV.
 - (2) Emission Level= Reading Level+ Probe Factor +Cable Loss.
 - (3) The average measurement was not performed when the peak measured data under the limit of average detection.
 - (4) Measuring frequencies from 1GHz to 25GHz.

7.6 Radiated Measurement Photos:

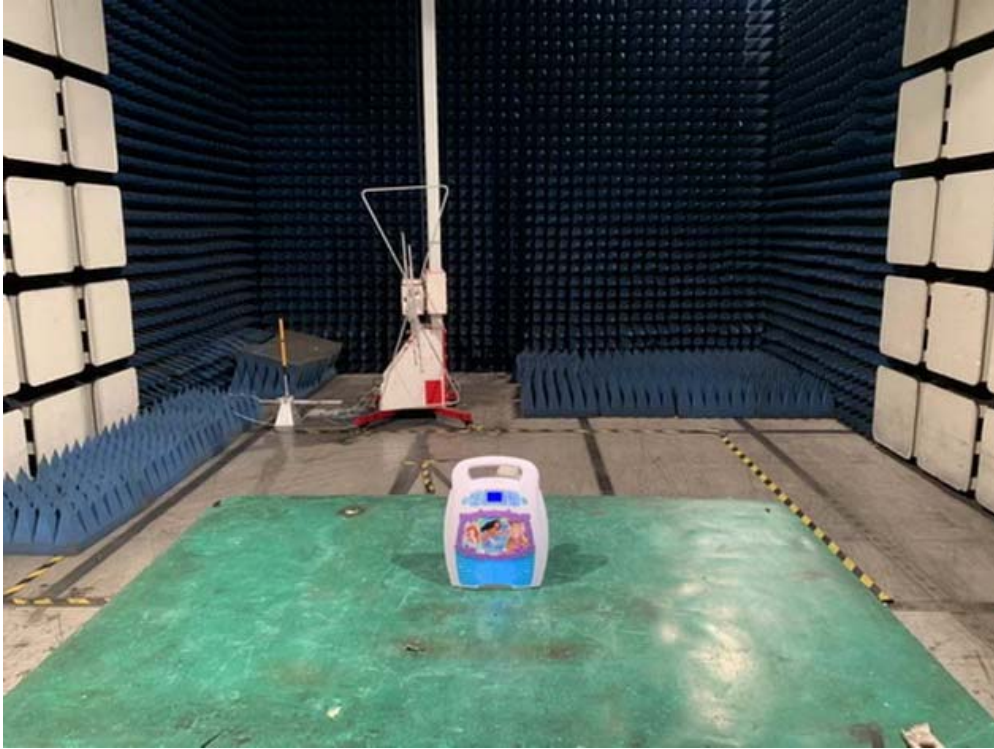

8. Channel Separation test

8.1 Measurement Procedure

The EUT was operating in hopping mode or could be controlled its channel. Printed out the test result from the spectrum by hard copy function.

8.2 Test SET-UP (Block Diagram of Configuration)

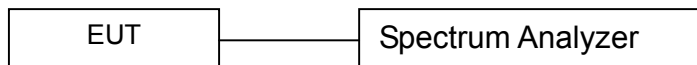

8.3 Measurement Equipment Used:

EQUIPMENT TYPE	MFR	MODEL NUMBER	SERIAL NUMBER	Characteristics	LAST CAL.	CAL DUE.
Spectrum Analyzer	Rohde & Schwarz	FSV30	1321.3008K	10Hz-30GHz	05/16/2018	05/15/2019
Coaxial Cable	CDS	79254	46107086	10Hz-30GHz	05/16/2018	05/15/2019
Antenna Connector	ARTHUR-YANG	2244-N1TG1	N/A	10Hz-30GHz	05/16/2018	05/15/2019

Remark: The temporary antenna connector is soldered on the PCB board in order to perform conducted tests and this temporary antenna connector is listed in the equipment list.

8.4 Measurement Results:

Refer to attached data chart.

Spectrum Detector: PK	Test Date : March 18, 2019
Test By: Yaping Shen	Temperature : 24°C
Test Result: PASS	Humidity : 56 %
Modulation: GFSK	

Channel number	Channel frequency (MHz)	Separation Read Value (kHz)	Separation Limit 2/3 20dB Down BW(kHz)
1	2402	1003	>747
40	2441	1003	>744
79	2480	1003	>753

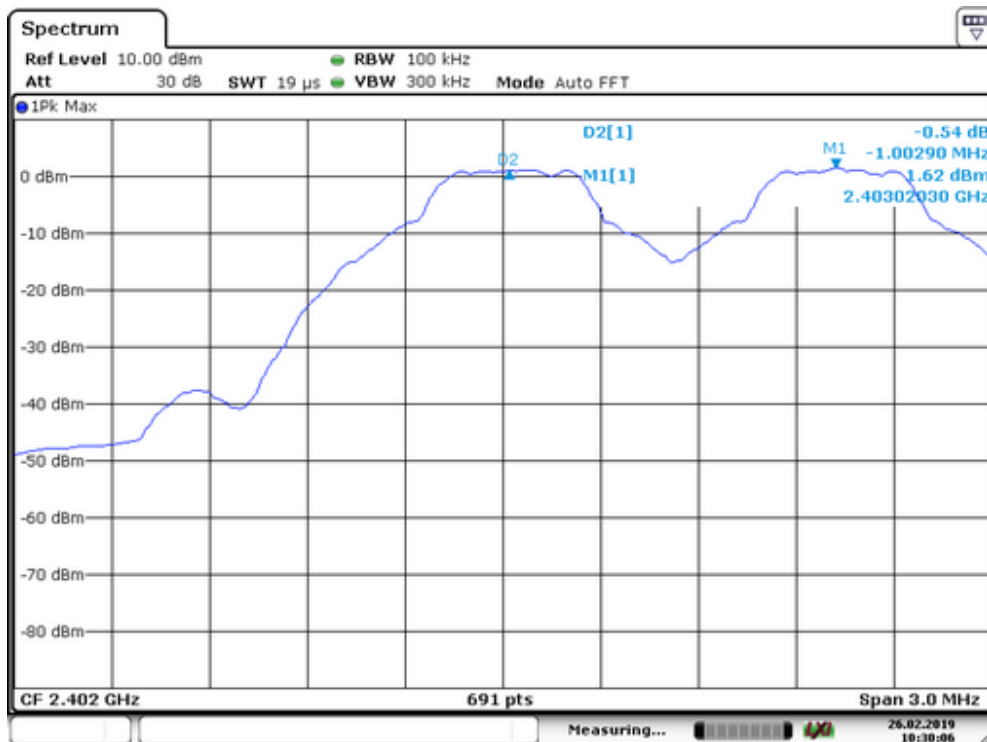

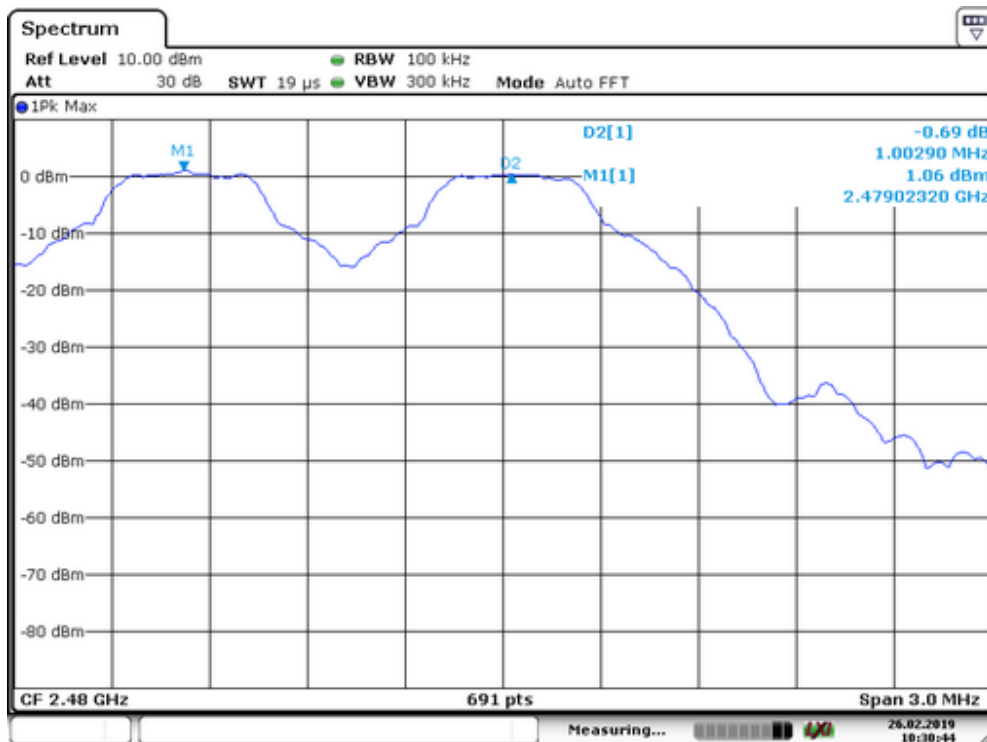
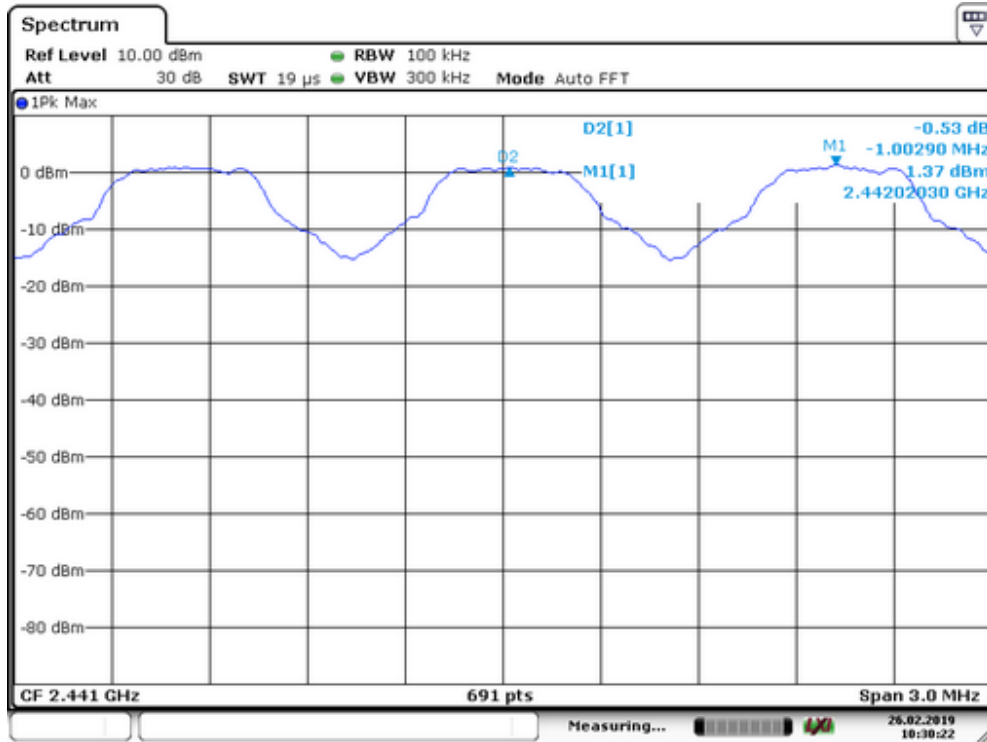

Spectrum Detector: PK	Test Date : March 18, 2019
Test By: Yaping Shen	Temperature : 24°C
Test Result: PASS	Humidity : 56 %
Modulation: Π/4-DQPSK	

Channel number	Channel frequency (MHz)	Separation Read Value (kHz)	Separation Limit 2/3 20dB Down BW(kHz)
1	2402	1003	>935
40	2441	1003	>935
79	2480	1003	>935

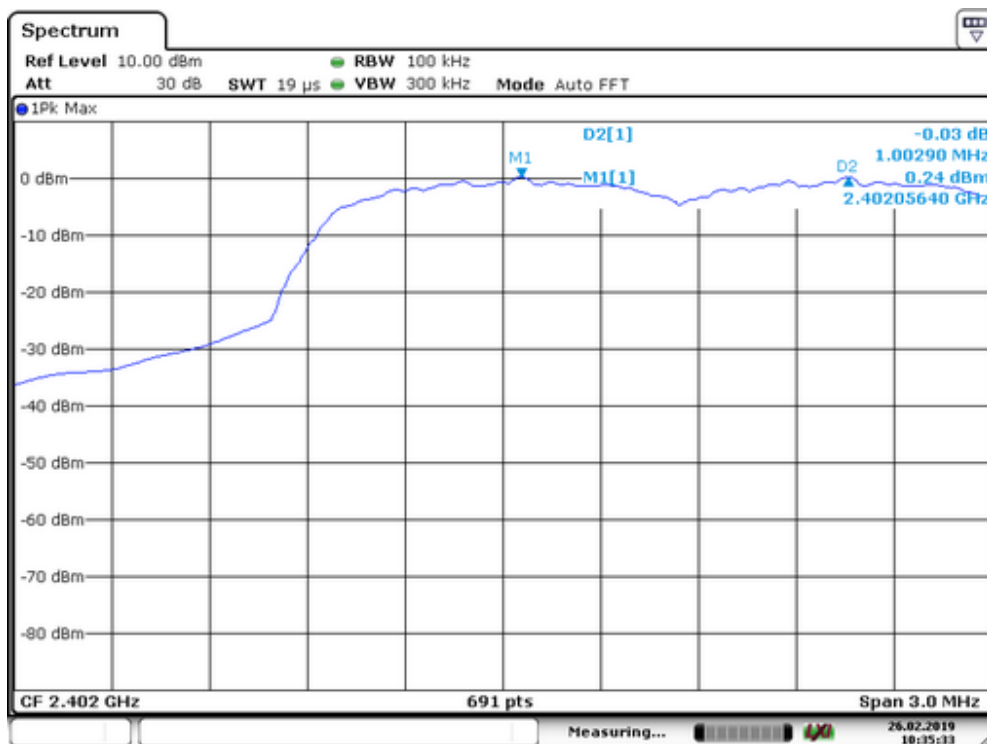

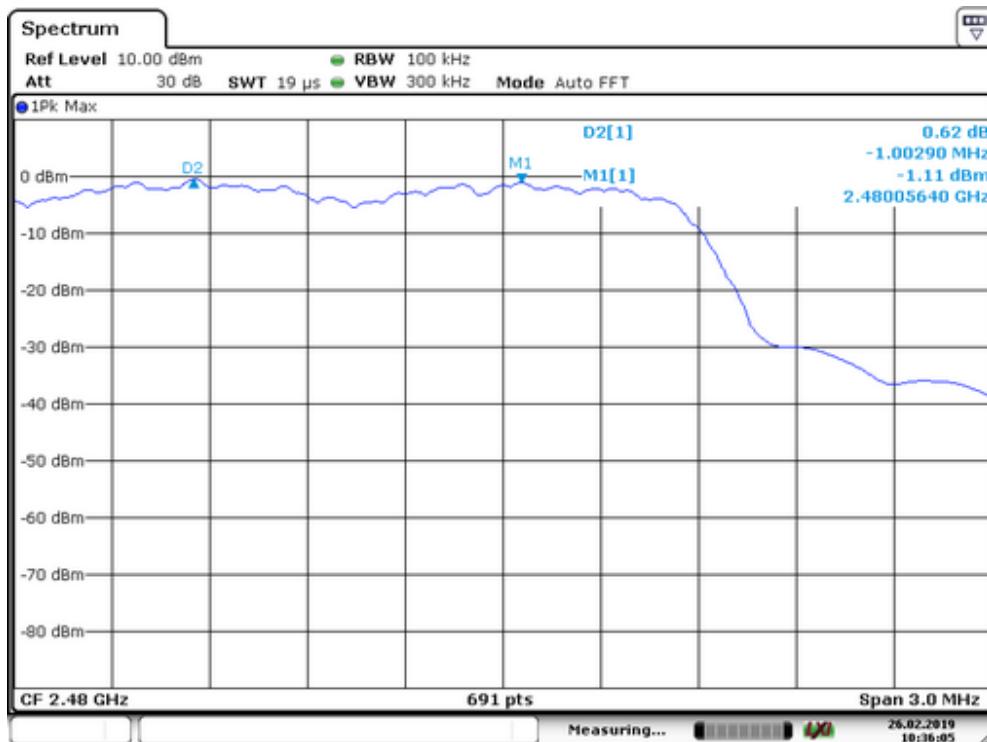
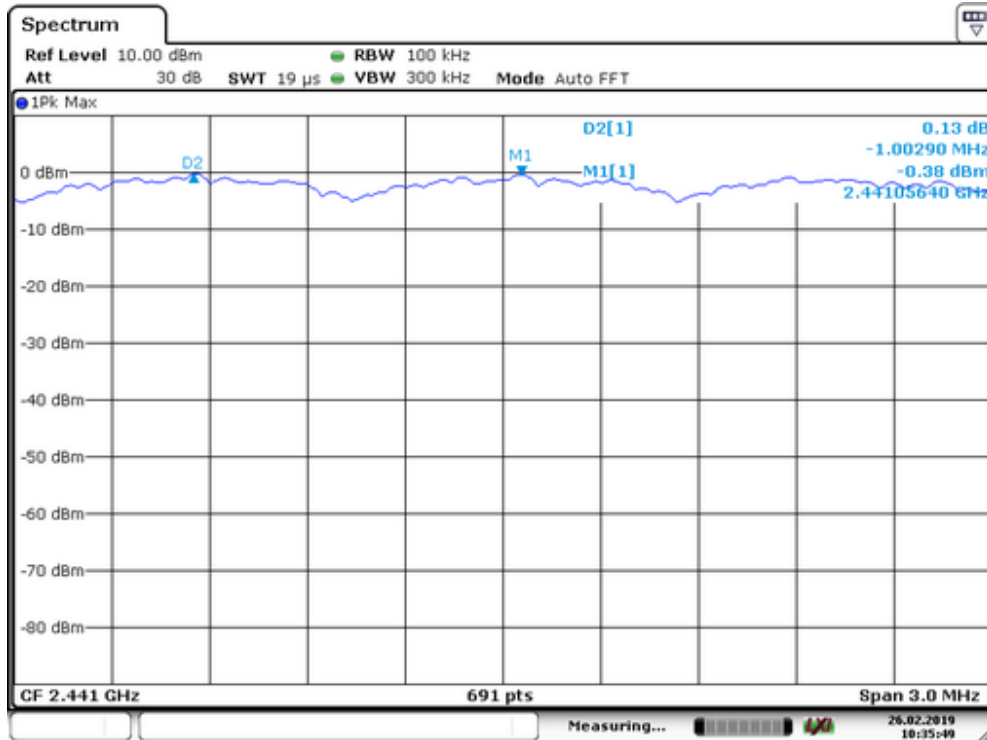

Spectrum Detector: PK	Test Date : March 18, 2019
Test By: Yaping Shen	Temperature : 24°C
Test Result: PASS	Humidity : 56 %
Modulation: 8DPSK	

Channel number	Channel frequency (MHz)	Separation Read Value (kHz)	Separation Limit 2/3 20dB Down BW(kHz)
1	2402	1003	>943
40	2441	1003	>938
79	2480	1003	>938

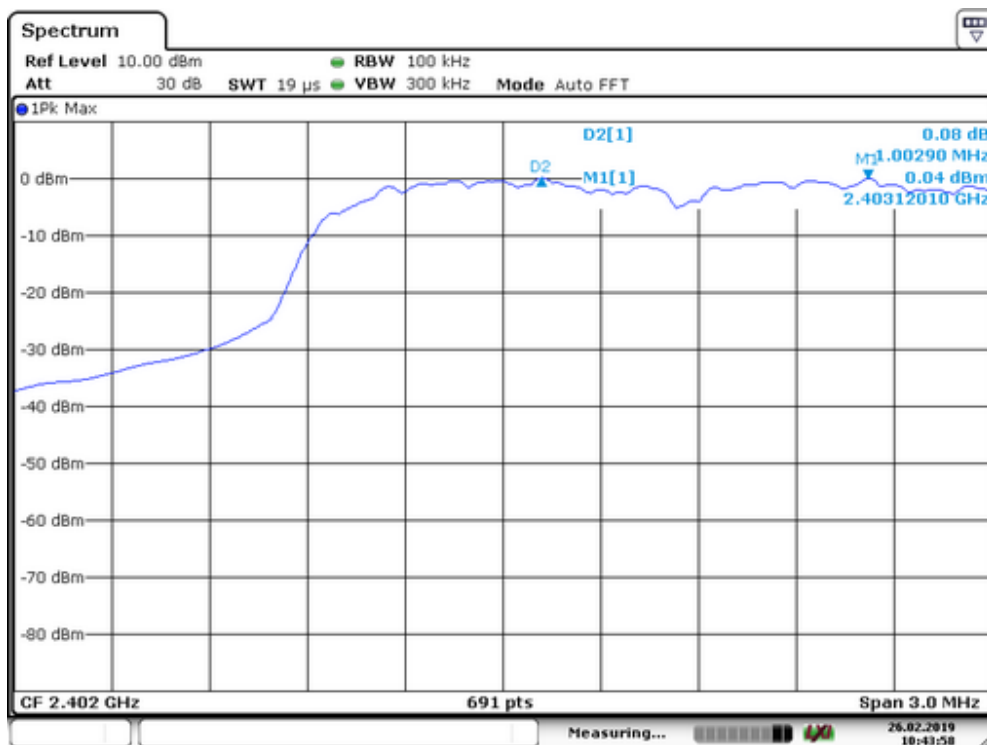

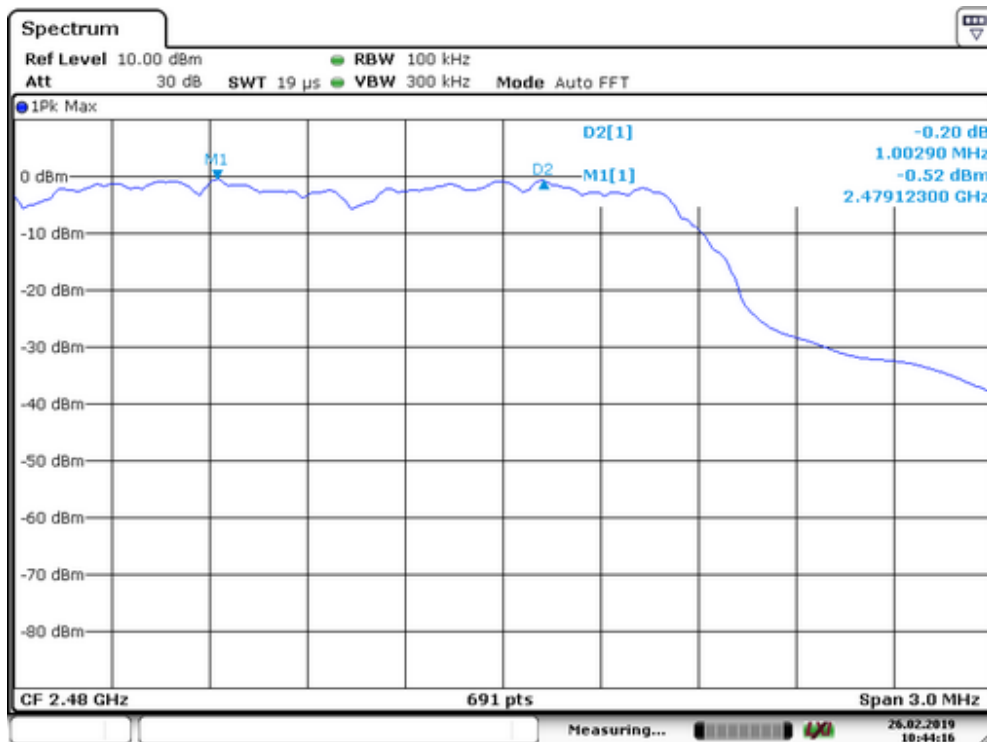
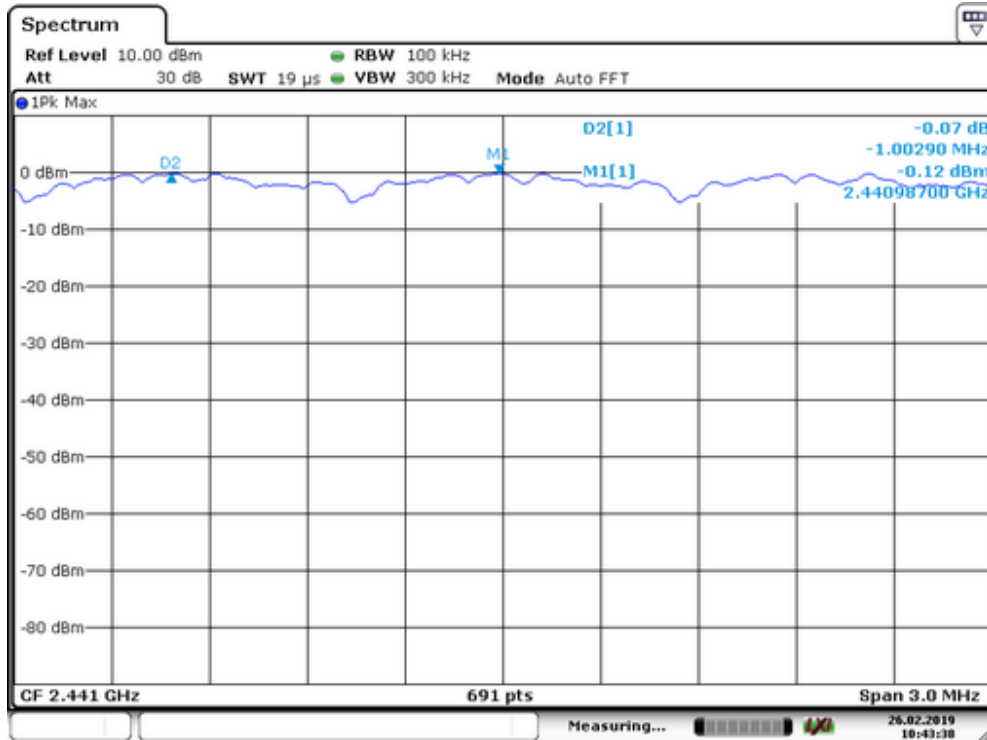

9. 20dB Bandwidth test

9.1 Measurement Procedure

The EUT was operating in hopping mode or could be controlled its channel. Printed out the test result from the spectrum by hard copy function.

9.2 Test SET-UP (Block Diagram of Configuration)

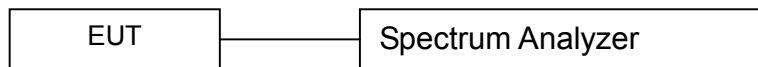

9.3 Measurement Equipment Used:

EQUIPMENT TYPE	MFR	MODEL NUMBER	SERIAL NUMBER	Characteristics	LAST CAL.	CAL DUE.
Spectrum Analyzer	Rohde & Schwarz	FSV30	1321.3008K	10Hz-30GHz	05/16/2018	05/15/2019
Coaxial Cable	CDS	79254	46107086	10Hz-30GHz	05/16/2018	05/15/2019
Antenna Connector	ARTHUR-YANG	2244-N1TG1	N/A	10Hz-30GHz	05/16/2018	05/15/2019

Remark: The temporary antenna connector is soldered on the PCB board in order to perform conducted tests and this temporary antenna connector is listed in the equipment list.

9.4 Measurement Results:

Refer to attached data chart.

Spectrum Detector:	PK	Test Date :	March 18, 2019
Test By:	Yaping Shen	Temperature :	24°C
Test Result:	PASS	Humidity :	56 %
Modulation:	GFSK		

Channel number	Channel frequency (MHz)	20dB Down BW(kHz)
1	2402	1120
40	2441	1116
79	2480	1129

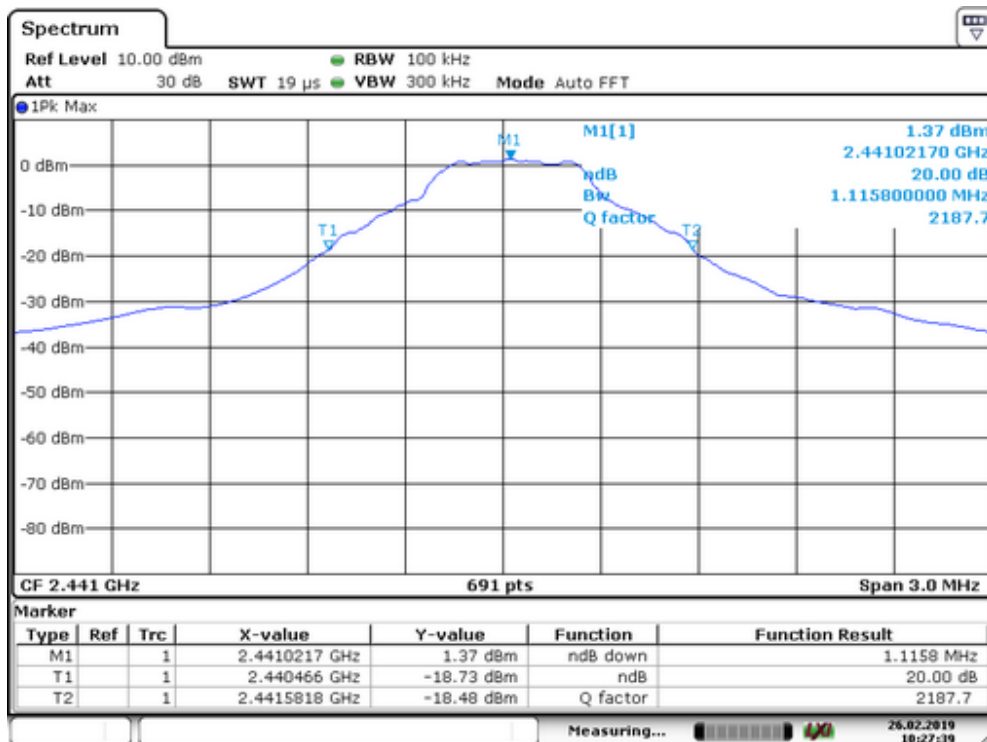
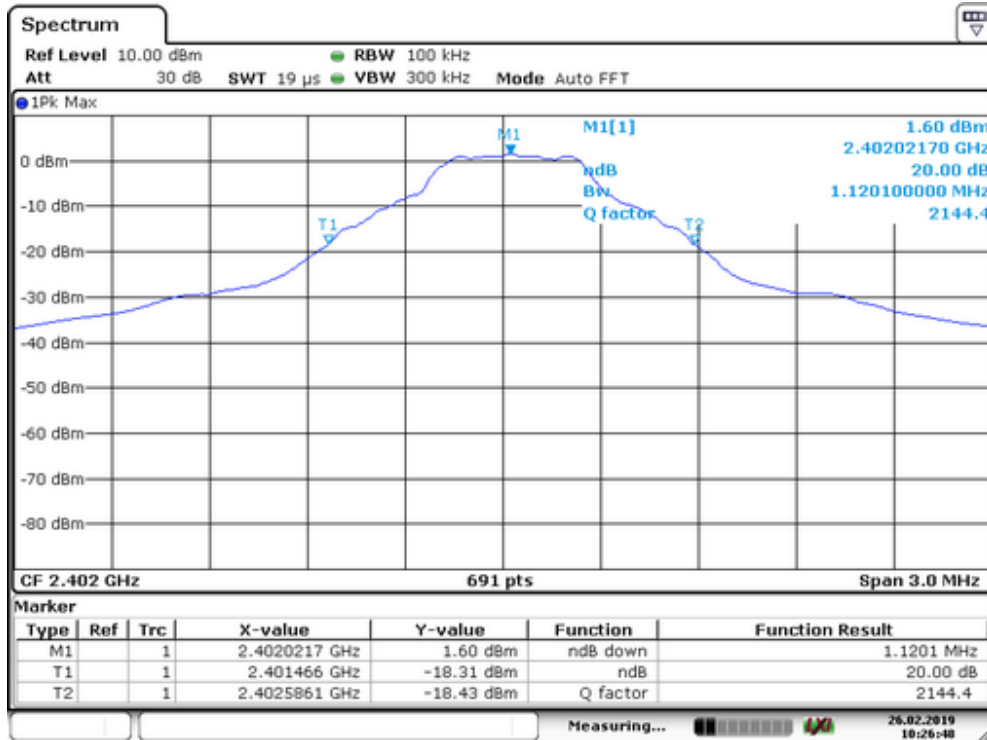

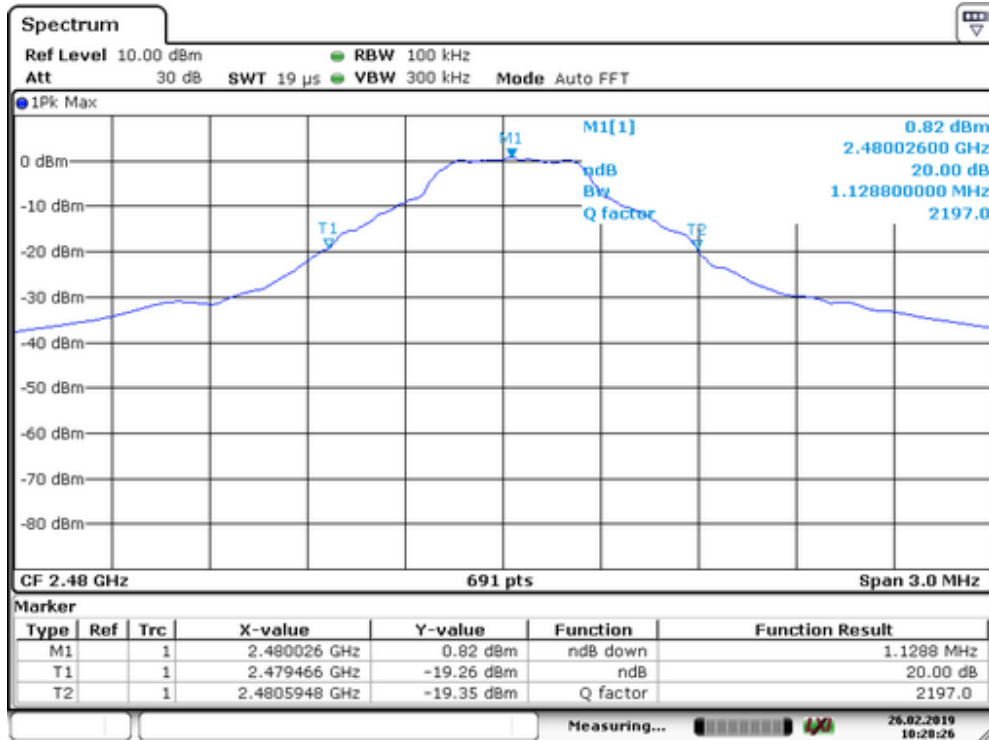

Spectrum Detector: PK	Test Date : March 18, 2019
Test By: Yaping Shen	Temperature : 24°C
Test Result: PASS	Humidity : 56 %
Modulation: $\Pi/4$ -DQPSK	

Channel number	Channel frequency (MHz)	20dB Down BW(kHz)
1	2402	1402
40	2441	1402
79	2480	1402

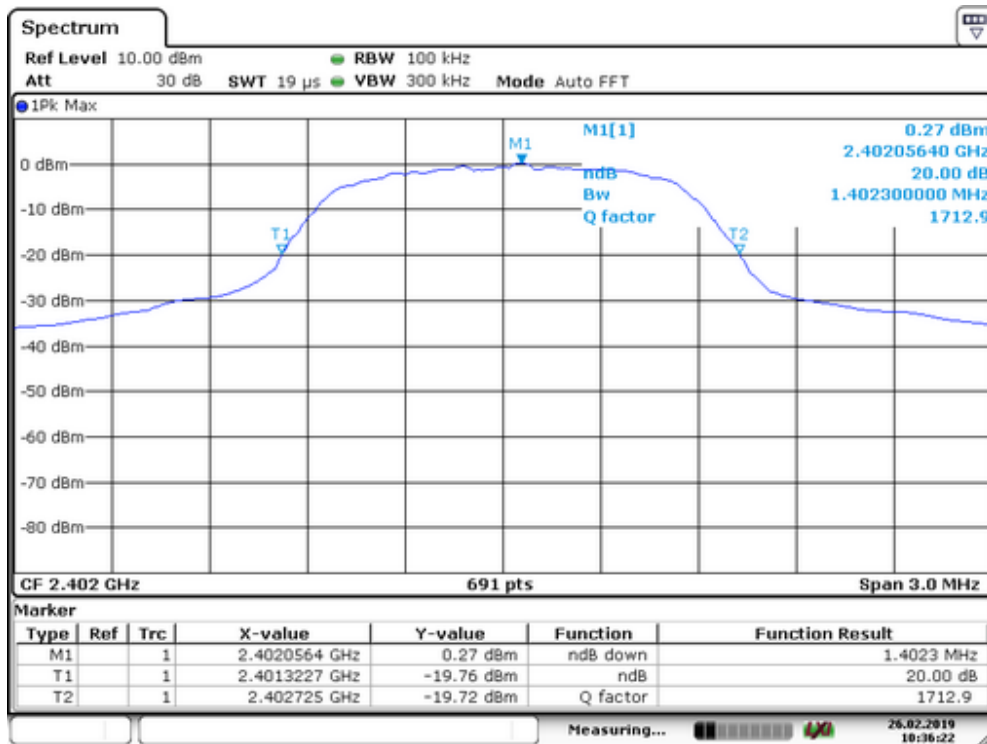

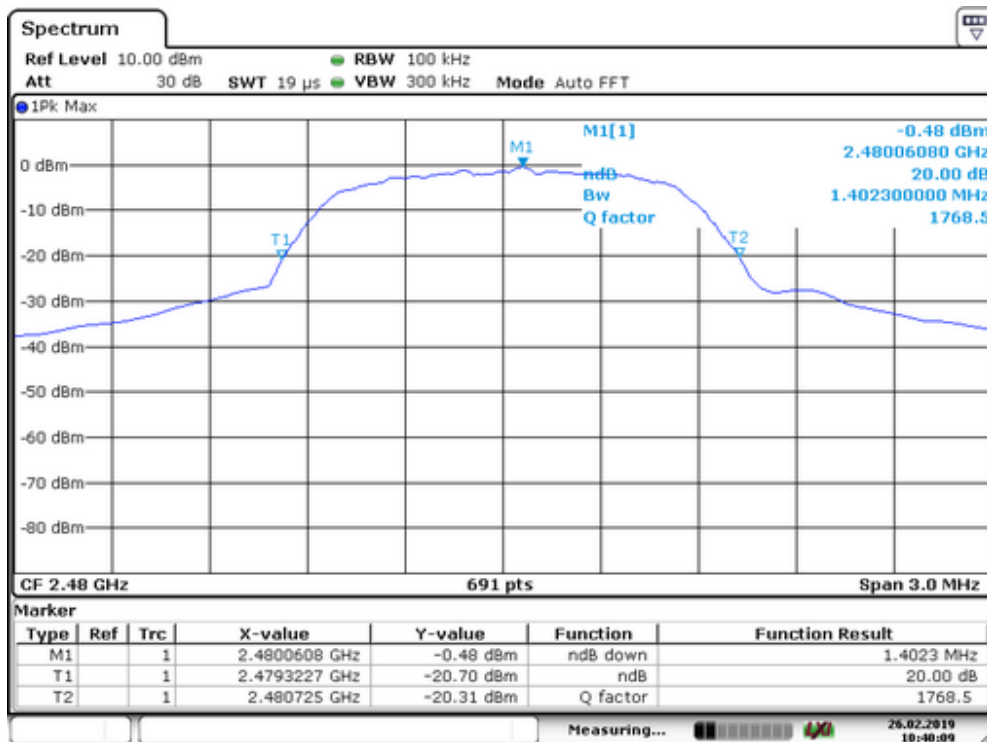
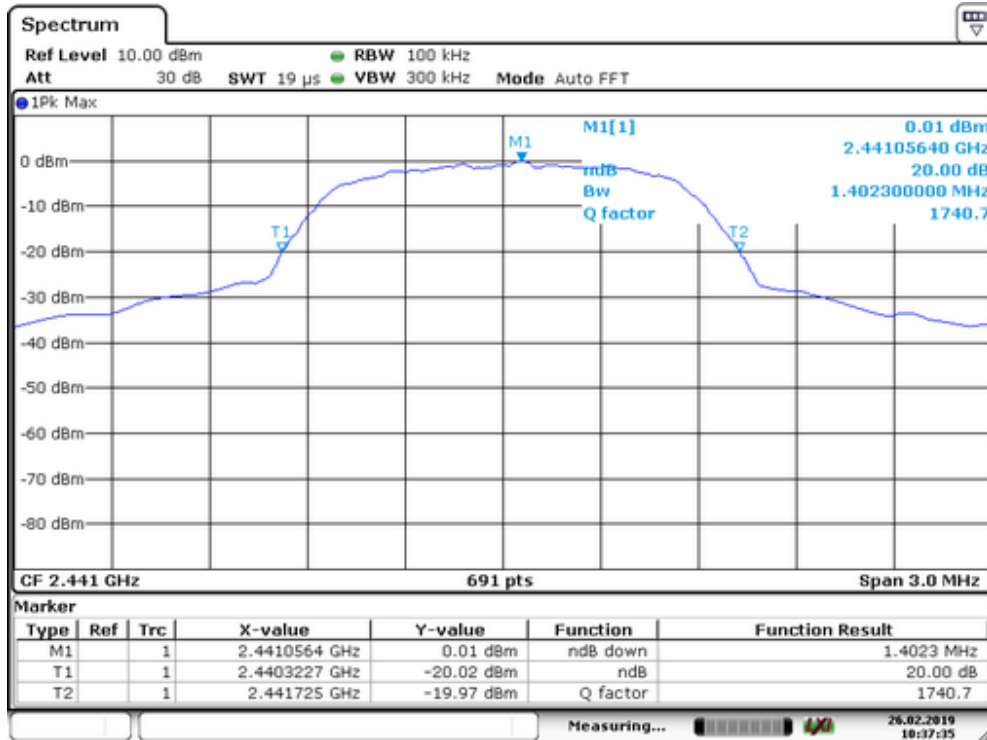

Spectrum Detector: PK	Test Date : March 18, 2019
Test By: Yaping Shen	Temperature : 24°C
Test Result: PASS	Humidity : 56 %
Modulation: 8DPSK	

Channel number	Channel frequency (MHz)	20dB Down BW(kHz)
1	2402	1415
40	2441	1407
79	2480	1407

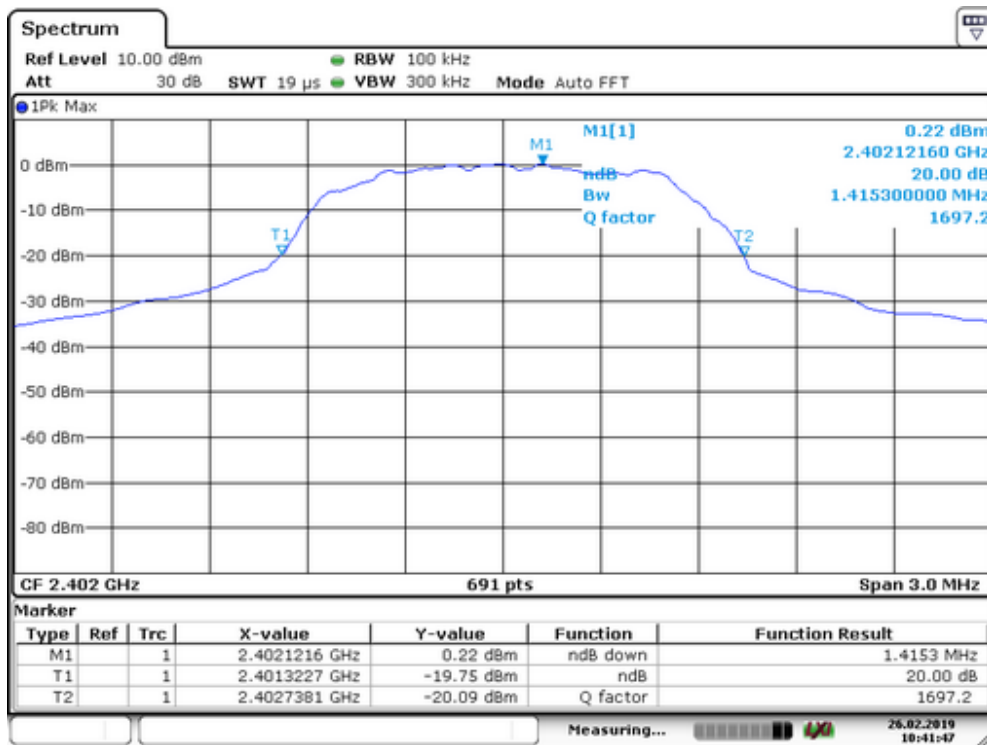

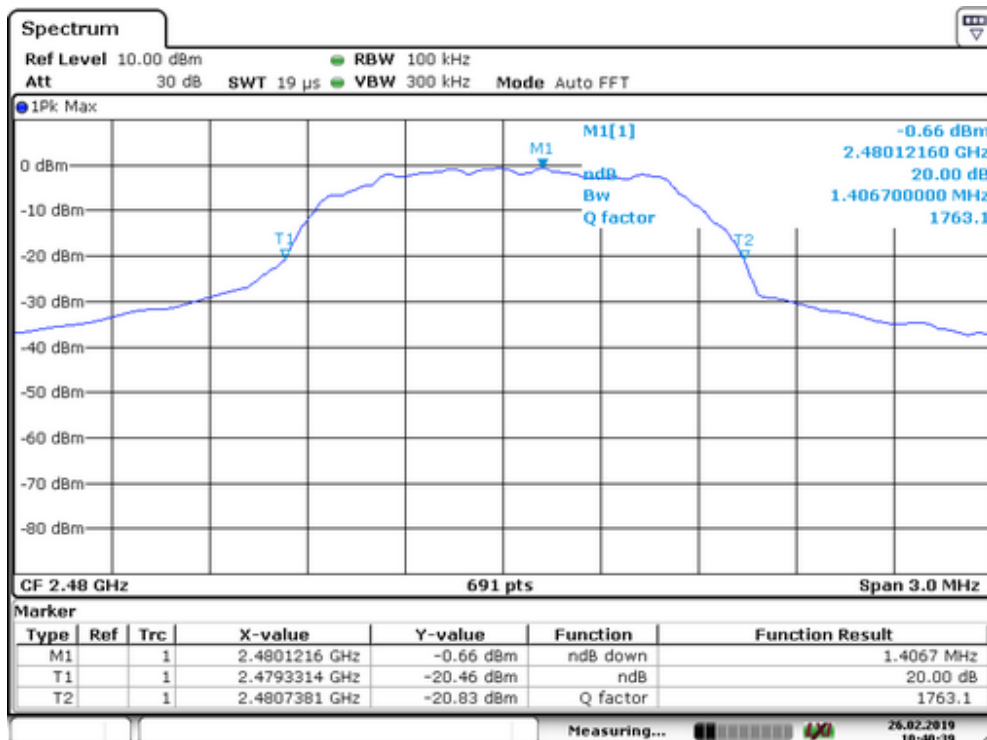
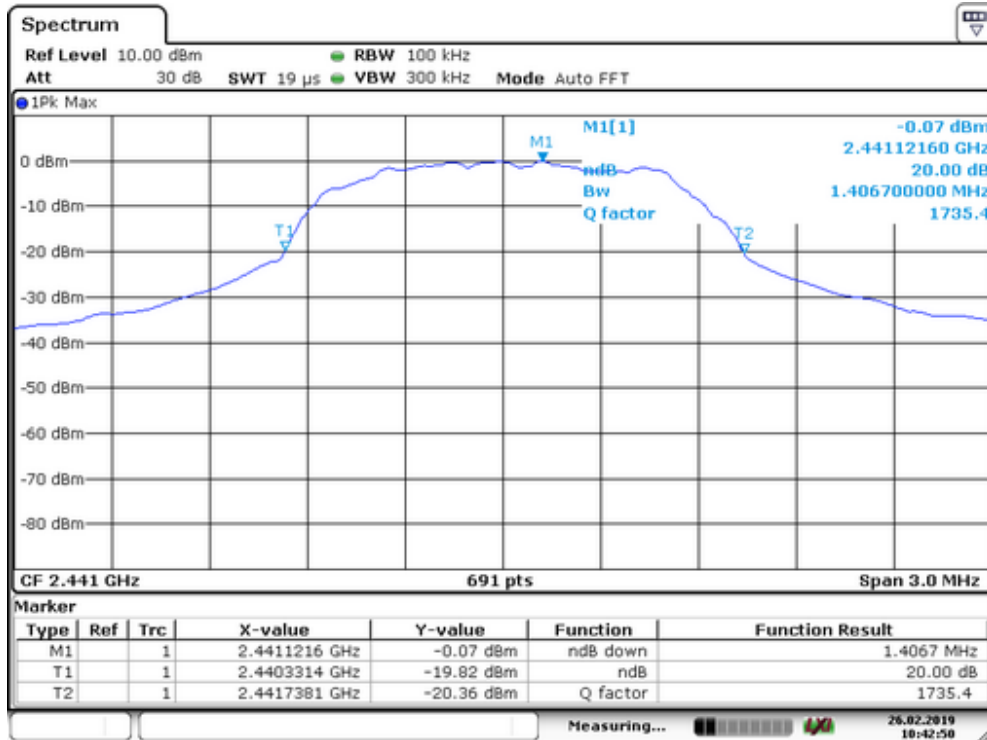

10. Quantity of Hopping Channel Test

10.1 Measurement Procedure

The EUT was operating in hopping mode or could be controlled its channel. Printed out the test result from the spectrum by hard copy function.

10.2 Test SET-UP (Block Diagram of Configuration)

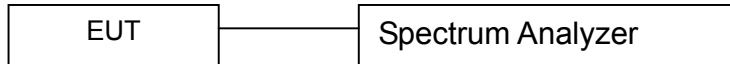

10.3 Measurement Equipment Used:

EQUIPMENT TYPE	MFR	MODEL NUMBER	SERIAL NUMBER	Characteristics	LAST CAL.	CAL DUE.
Spectrum Analyzer	Rohde & Schwarz	FSV30	1321.3008K	10Hz-30GHz	05/16/2018	05/15/2019
Coaxial Cable	CDS	79254	46107086	10Hz-30GHz	05/16/2018	05/15/2019
Antenna Connector	ARTHUR-YANG	2244-N1TG1	N/A	10Hz-30GHz	05/16/2018	05/15/2019

Remark: The temporary antenna connector is soldered on the PCB board in order to perform conducted tests and this temporary antenna connector is listed in the equipment list.

10.4 Measurement Results:

Refer to attached data chart.

Worst Test Mode	GFSK	Test Date :	March 18, 2019
Test By:	Yaping Shen	Temperature :	24 °C
Test Result:	PASS	Humidity :	56 %

Hopping Channel Frequency Range	Quantity of Hopping Channel	Quantity of Hopping Channel
2402-2480	79	> 15

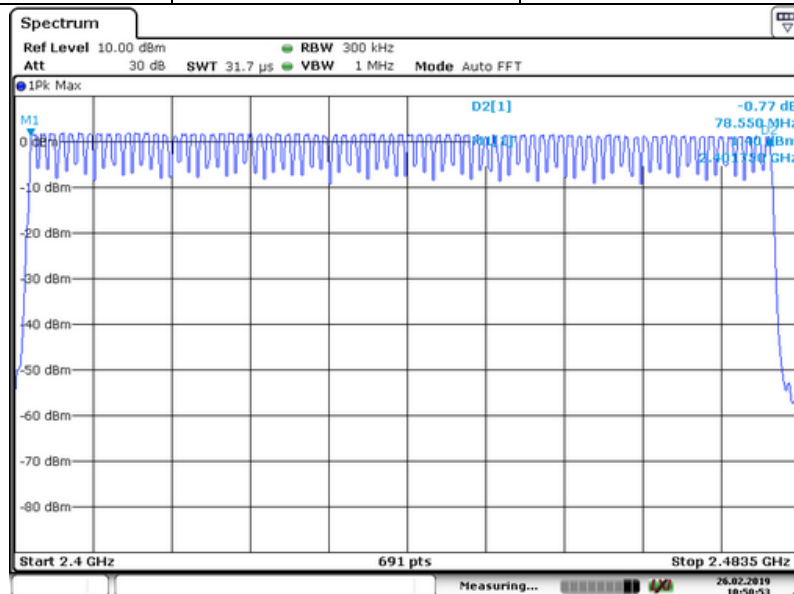

11. Time of Occupancy (Dwell Time) test

11.1 Test Description

The Equipment Under Test (EUT) was set up to perform the dwell time measurements. The EUT was connected to the spectrum analyzer via a short coax cable. The dwell time is calculated by:

$$\text{Dwell time} = \text{time slot length} * \text{hop rate} / \text{number of hopping channels} * 31.6\text{s}$$

with:

- hop rate = $1600 * 1/\text{s}$ for DH1 packets = 1600 s^{-1}
- hop rate = $1600/3 * 1/\text{s}$ for DH3 packets = 533.33 s^{-1}
- number of hopping channels = 79
- $31.6 \text{ s} = 0.4 \text{ seconds multiplied by the number of hopping channels} = 0.4 \text{ s} * 79$

The highest value of the dwell time is reported.

11.2 Test SET-UP (Block Diagram of Configuration)

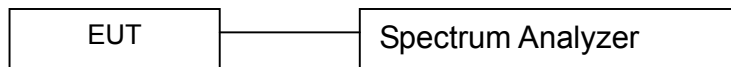

11.3 Measurement Equipment Used:

EQUIPMENT TYPE	MFR	MODEL NUMBER	SERIAL NUMBER	Characteristics	LAST CAL.	CAL DUE.
Spectrum Analyzer	Rohde & Schwarz	FSV30	1321.3008K	10Hz-30GHz	05/16/2018	05/15/2019
Coaxial Cable	CDS	79254	46107086	10Hz-30GHz	05/16/2018	05/15/2019
Antenna Connector	ARTHUR-YANG	2244-N1TG1	N/A	10Hz-30GHz	05/16/2018	05/15/2019

Remark: The temporary antenna connector is soldered on the PCB board in order to perform conducted tests and this temporary antenna connector is listed in the equipment list.

11.4 Test Requirements / Limits

FCC Part 15, Subpart C, §15.247 (a) (1) (iii)

Frequency hopping systems in the 2400-2483.5 MHz band shall use at least 15 channels. The average time of occupancy on any channel shall not be greater than 0.4 seconds within a period of 0.4 seconds multiplied by the number of hopping channels employed. Since the Bluetooth technology uses 79 channels this period is calculated to be 31.6seconds. Refer to attached data chart.

Modulation:	GFSK	Test Date :	March 18, 2019
Test By:	Yaping Shen	Temperature :	24 °C
Test Result:	PASS	Humidity :	56 %

11.5 Test result

Mode	Number of transmission in a 31.6(79 Hopping*0.4)	Length of transmissions time(msec)	Result (msec)	Limit (msec)
DH1	$1600/(2*79) \times 31.6 = 320$	0.399	127.68	400
DH3	$1600/(4*79) \times 31.6 = 160$	1.657	265.12	400
DH5	$1600/(6*79) \times 31.6 = 106.67$	2.942	313.82	400

Remark: The results of worst cased was recorded.

DH1:

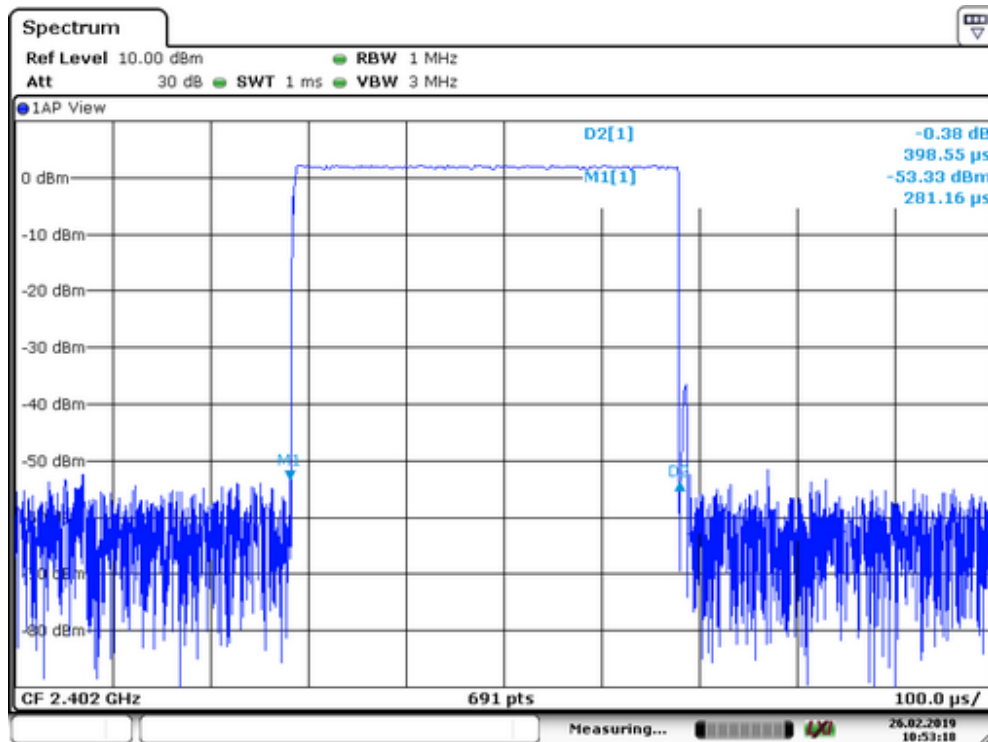

DH3:

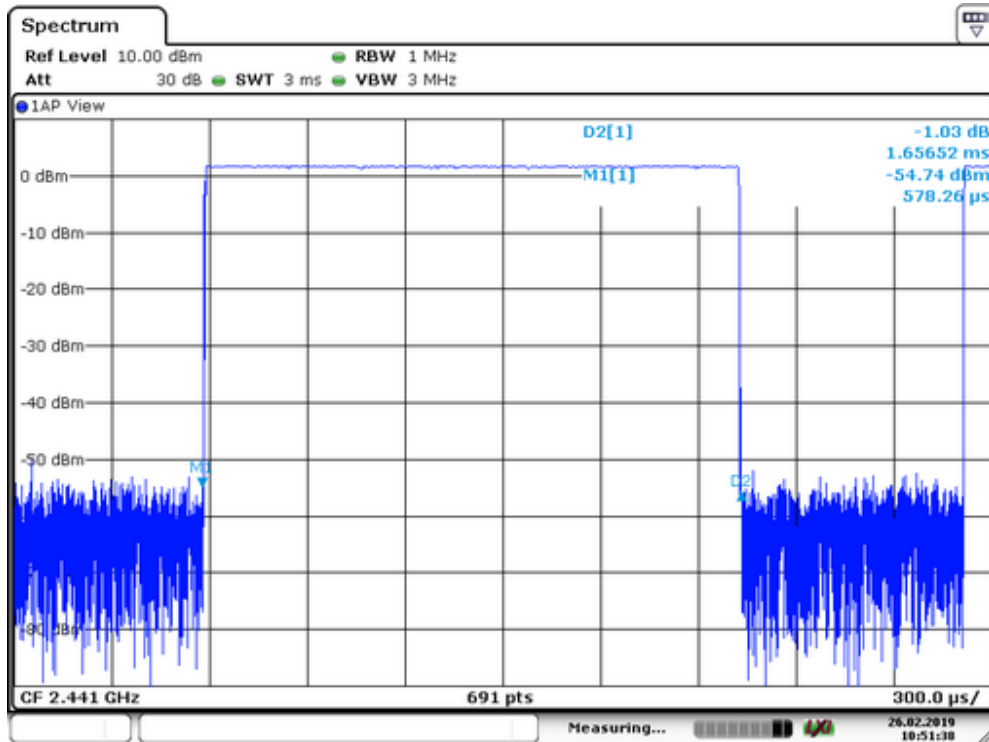

DH5:

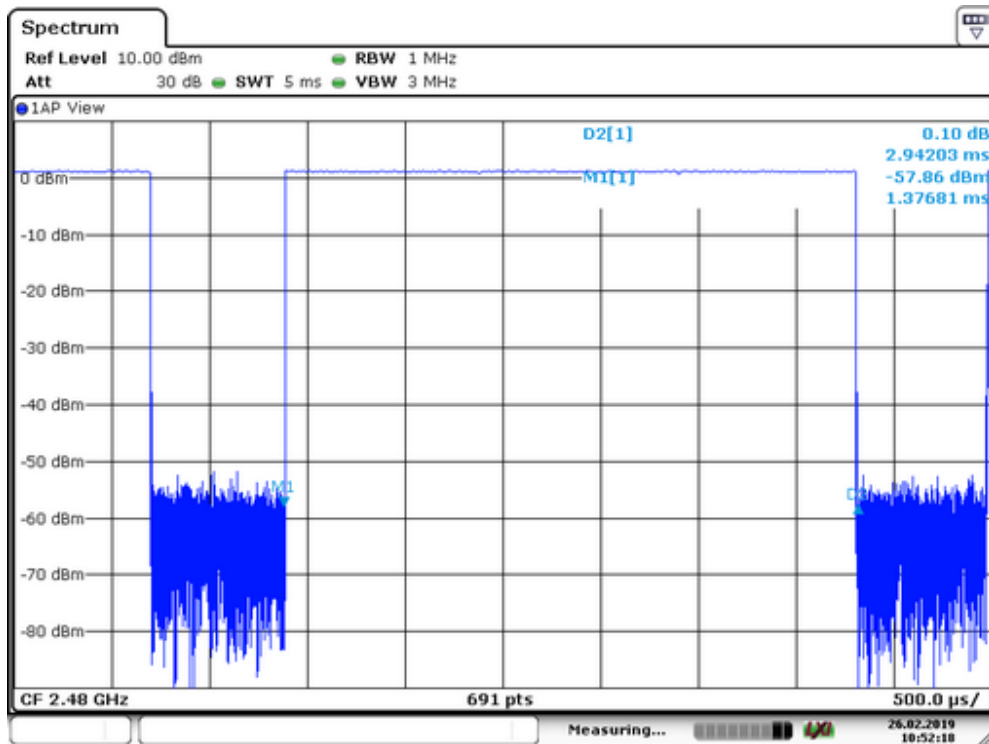

12. MAXIMUM PEAK OUTPUT POWER TEST

12.1 Measurement Procedure

- a. Check the calibration of the measuring instrument(SA) using either an internal calibrator or a known signal from an external generator.
- b. Turn on the EUT and connect it to measurement instrument. Then set it to any one convenient frequency within its operating range. Set a reference level on the measuring instrument equal to the highest peak value.
- c. The center frequency of the spectrum analyzer is set to the fundamental frequency and using proper RBW and VBW setting.
- d. Measure the captured power within the band and recording the plot.
- e. Repeat above procedures until all frequencies required were complete.

12.2 Test SET-UP (Block Diagram of Configuration)

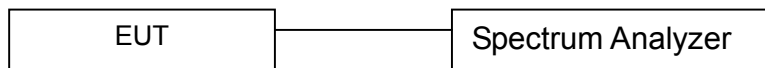

12.3 Measurement Equipment Used:

EQUIPMENT TYPE	MFR	MODEL NUMBER	SERIAL NUMBER	Characteristics	LAST CAL.	CAL DUE.
Spectrum Analyzer	Rohde & Schwarz	FSV30	1321.3008K	10Hz-30GHz	05/16/2018	05/15/2019
Coaxial Cable	CDS	79254	46107086	10Hz-30GHz	05/16/2018	05/15/2019
Antenna Connector	ARTHUR-YANG	2244-N1TG1	N/A	10Hz-30GHz	05/16/2018	05/15/2019

Remark: The temporary antenna connector is soldered on the PCB board in order to perform conducted tests and this temporary antenna connector is listed in the equipment list.

12.4 Measurement Results:

Refer to attached data chart.

Spectrum Detector:	PK	Test Date :	March 18, 2019
Test By:	Yaping Shen	Temperature :	24 °C
Test Result:	PASS	Humidity :	56 %
Modulation:	GFSK		

Channel number	Channel Frequency (MHz)	Peak Power output(dBm)	Peak Power output(mW)	Peak Power Limit(mW)	Pass/Fail
01	2402	1.89	1.545	1000	PASS
40	2441	1.66	1.466	1000	PASS
79	2480	1.16	1.306	1000	PASS

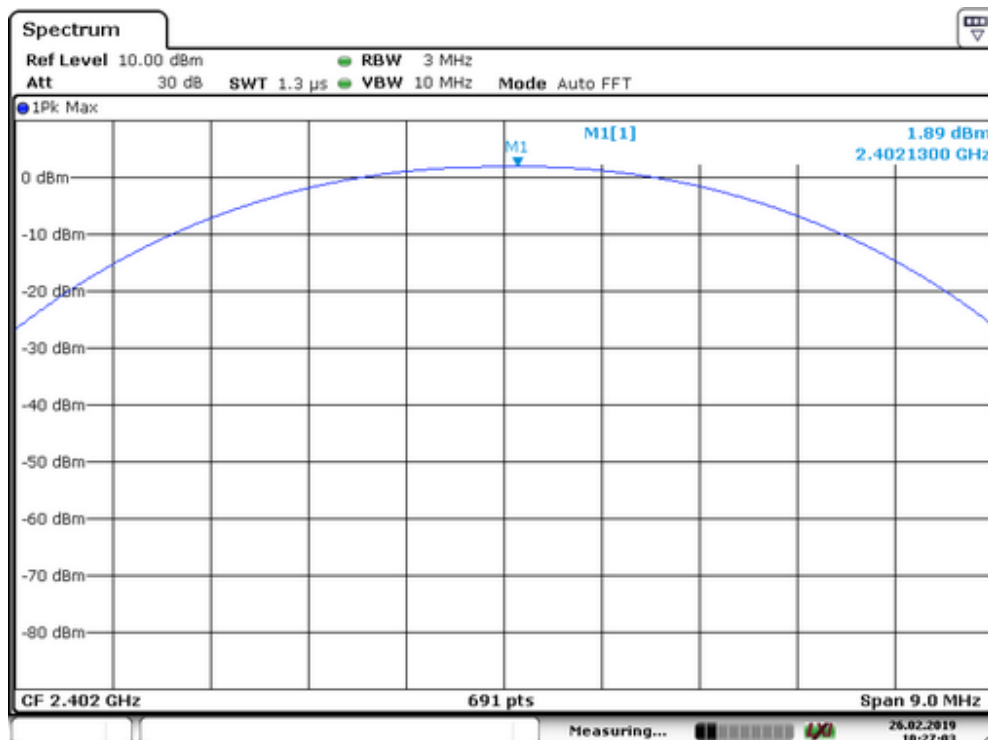

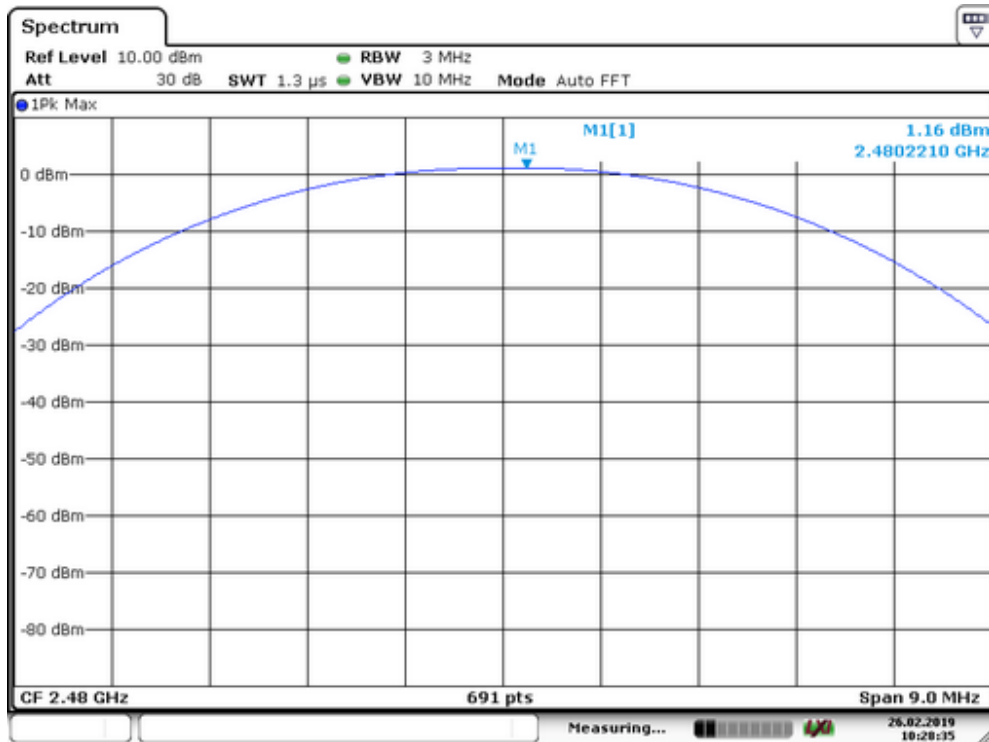
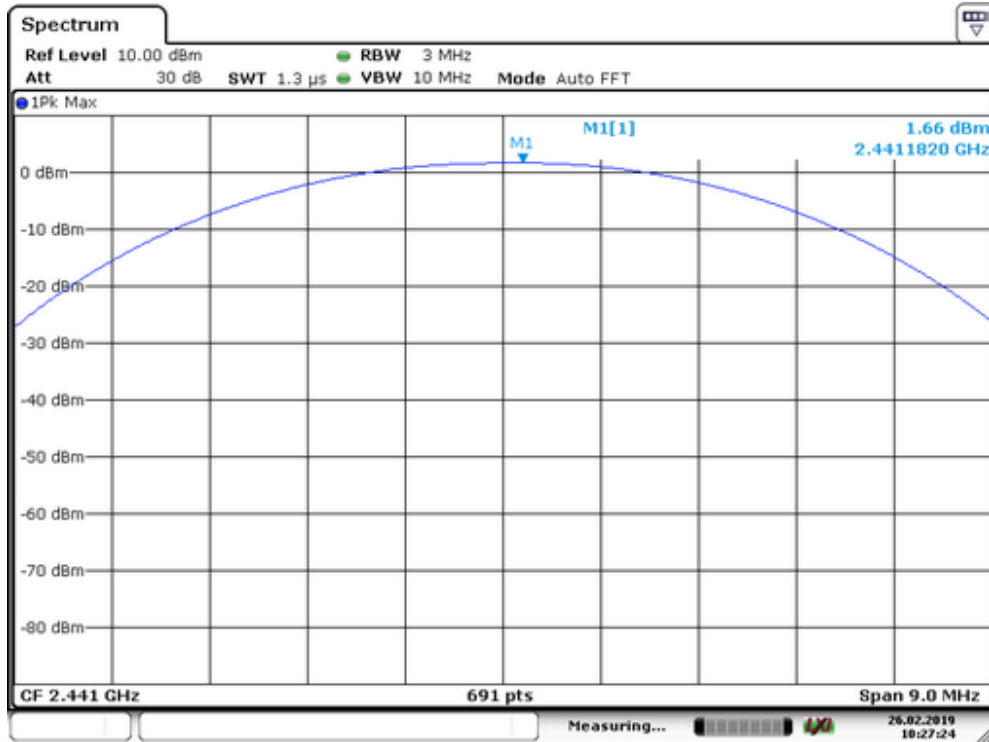

Spectrum Detector: PK Test Date : March 18, 2019
 Test By: Yaping Shen Temperature : 24 °C
 Test Result: PASS Humidity : 56 %
 Modulation: Π/4-DQPSK

Channel number	Channel Frequency (MHz)	Peak Power output(dBm)	Peak Power output(mW)	Peak Power Limit(mW)	Pass/Fail
01	2402	4.01	2.518	125	PASS
40	2441	3.76	2.377	125	PASS
79	2480	3.03	2.009	125	PASS

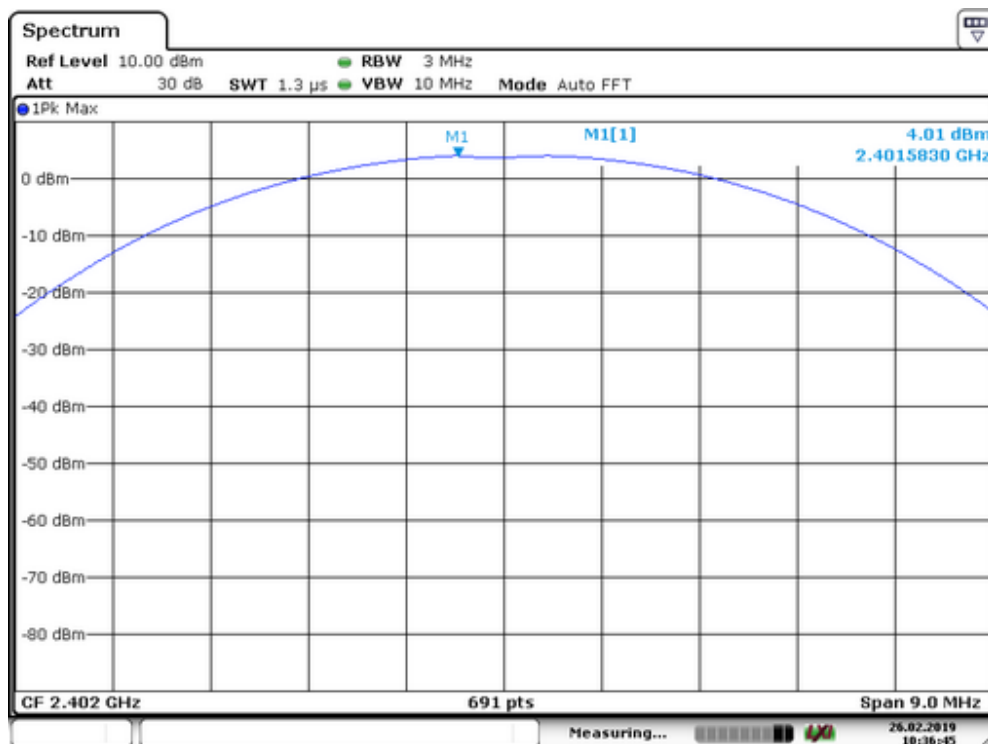

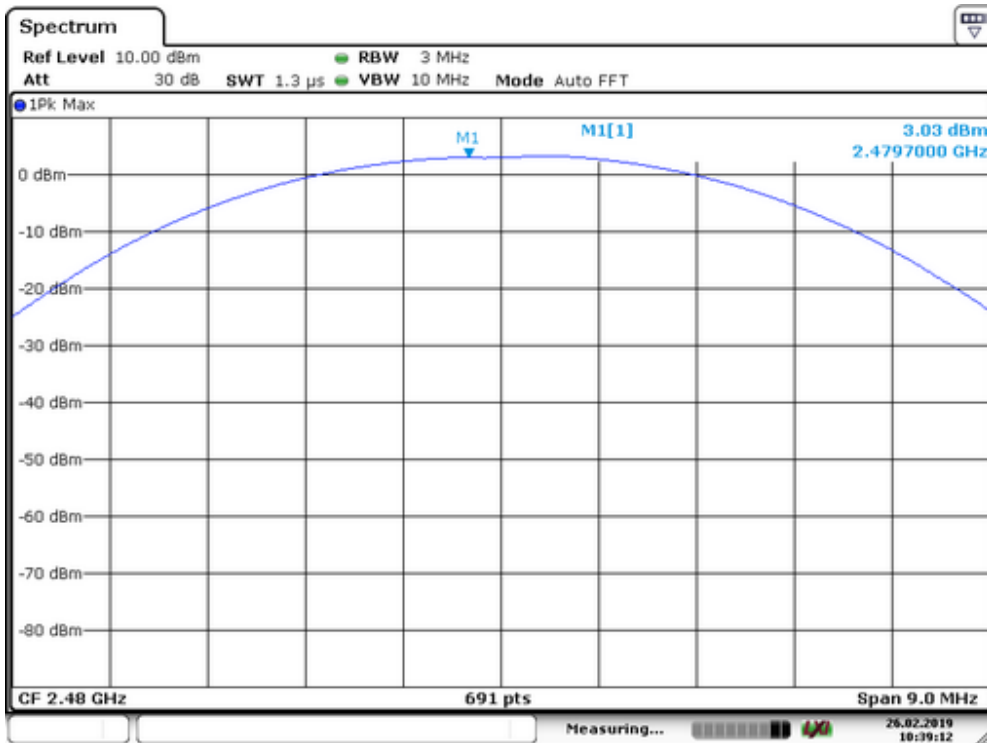
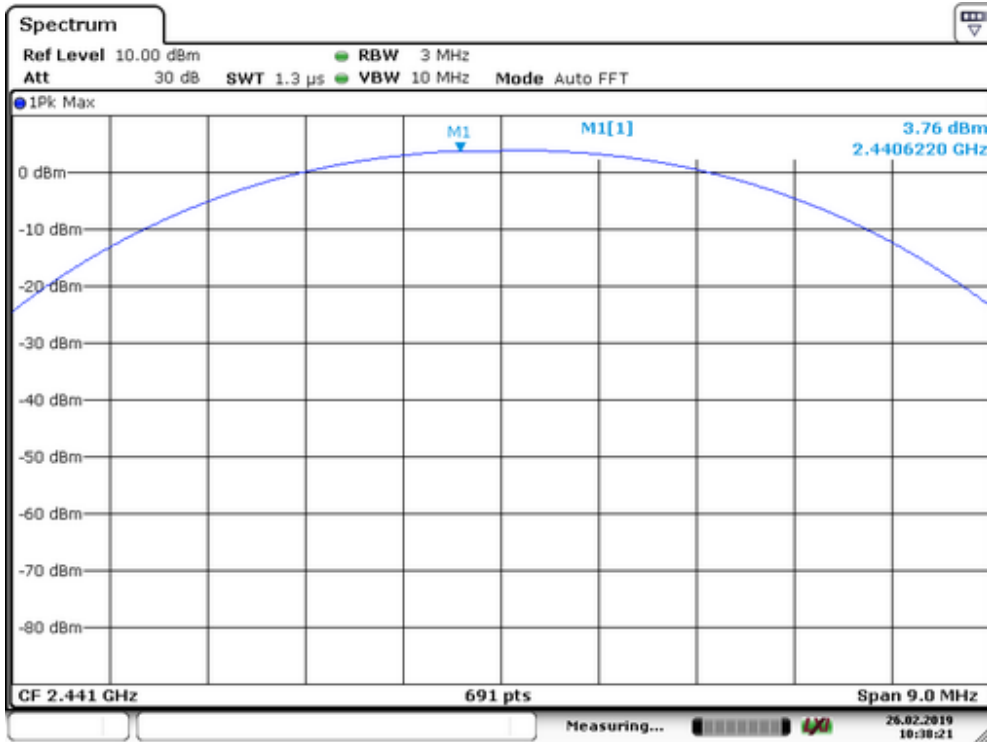

Spectrum Detector: PK Test Date : March 18, 2019
 Test By: Yaping Shen Temperature : 24 °C
 Test Result: PASS Humidity : 56 %
 Modulation: 8DPSK

Channel number	Channel Frequency (MHz)	Peak Power output(dBm)	Peak Power output(mW)	Peak Power Limit(mW)	Pass/Fail
01	2402	4.33	2.710	125	PASS
40	2441	3.93	2.472	125	PASS
79	2480	4.48	2.805	125	PASS

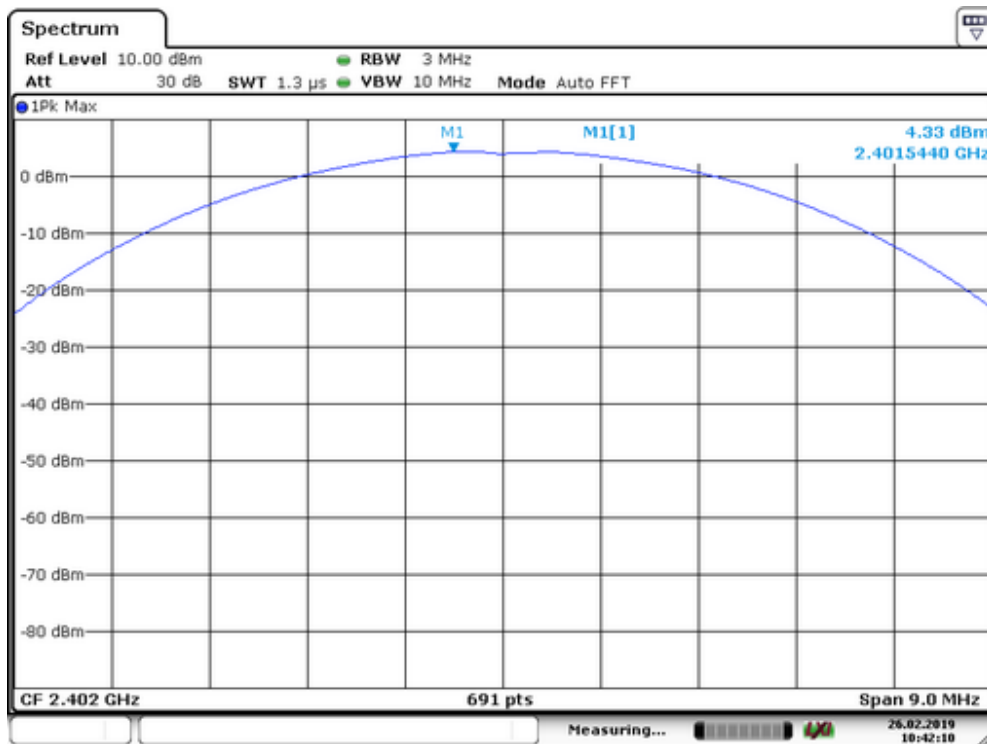

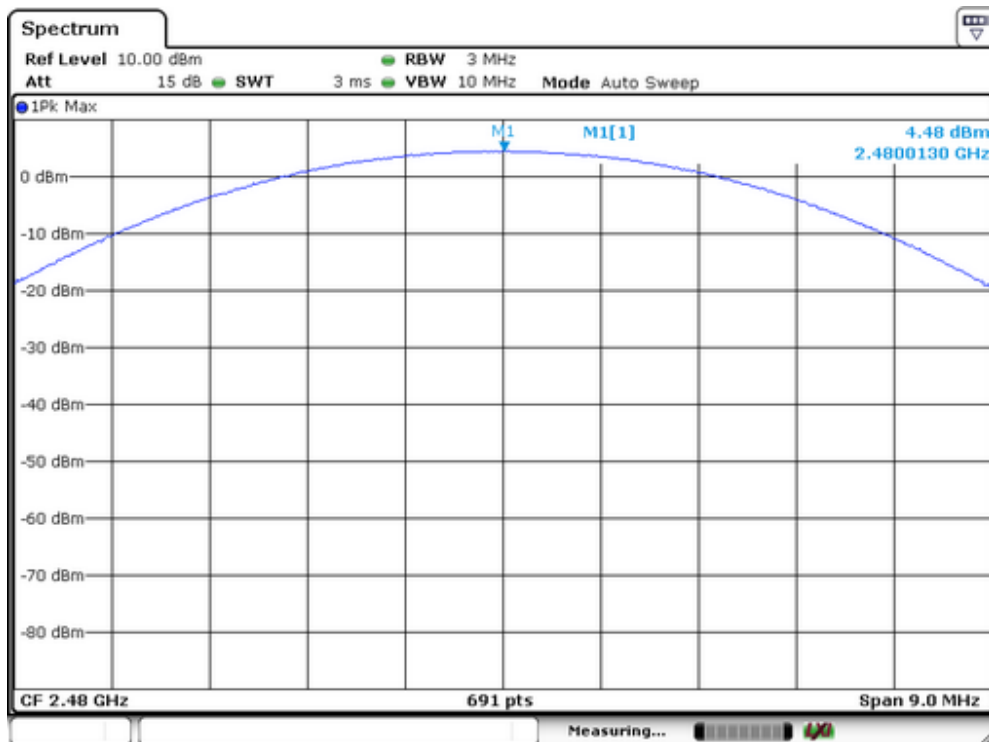
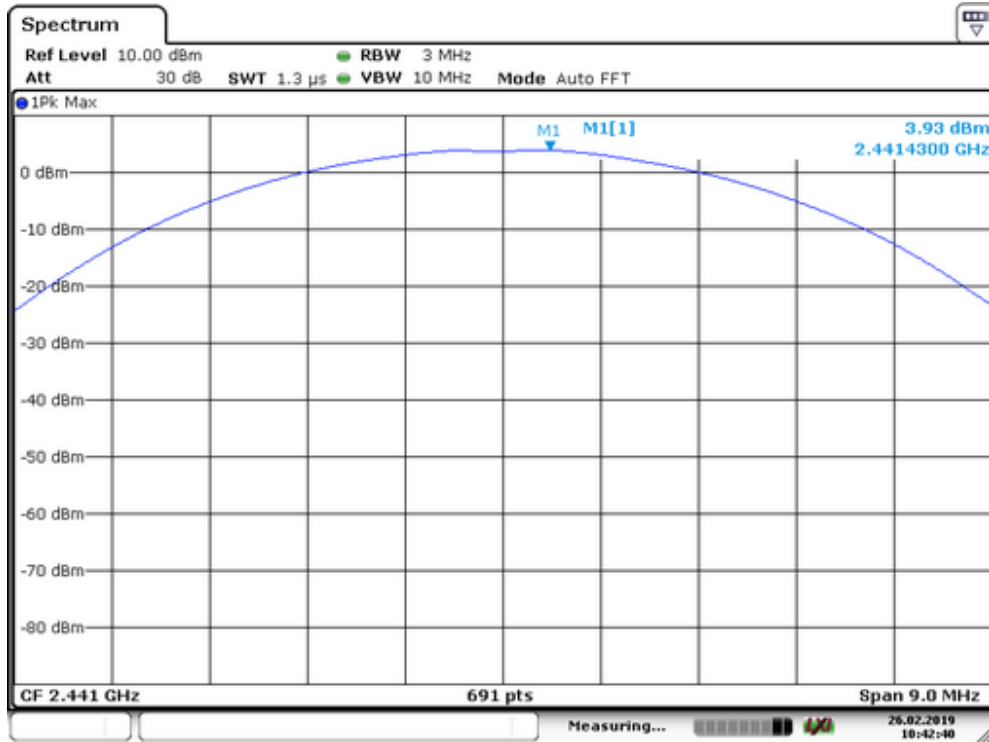

13. Band EDGE test

13.1 Measurement Procedure

For Conducted Test

1. The transmitter output is connected to a spectrum analyzer. The resolution bandwidth is set to 100KHz. The video bandwidth is set to 300KHz.
2. The spectrum from 30MHz to 26 GHz is investigated with the transmitter set to the lowest, middle, and highest channels.

EMI Test Receiver	Setting
Attenuation	Auto
RBW	100KHz
VBW	300KHz
Detector	Peak
Trace	Max hold

For Radiated emission Test

The EUT was placed on a styrofoam table which is 1.5m above ground plane.

The measurement procedure at the ban edges was simplified by performing the measurement in just one plot. Both, the in-band-emission and the unwanted emission were be encompassed by the span. After trace stabilization, the maximum peak was be determined by a peak detector and the value was marked by an appropriate limit line. The second limit line, which is 20dB below the first, marks the limit for the emissions in the unrestricted band. A maximum-peak-detector marks the highest emission in the unrestricted band next to the band edge.

The measurements were performed at the lower end of the 2.4GHz band.

Use the following spectrum analyzer settings:

For Restricted Band, When spectrum scanned above 1GHz setting resolution bandwidth 1MHz, video bandwidth 3MHz:

EMI Test Receiver	Setting
Attenuation	Auto
RBW	1MHz
VBW	3MHz
Detector	Peak
Trace	Max hold

For Non-Restricted Band, When spectrum scanned above 1GHz setting resolution bandwidth 100KHz, video bandwidth 300KHz:

EMI Test Receiver	Setting
Attenuation	Auto
RBW	100KHz
VBW	300KHz
Detector	Peak
Trace	Max hold

13.2 Test SET-UP (Block Diagram of Configuration)

For Conducted Test

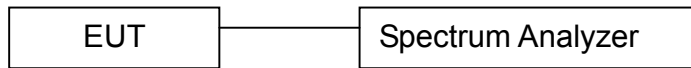

For Radiated emission Test

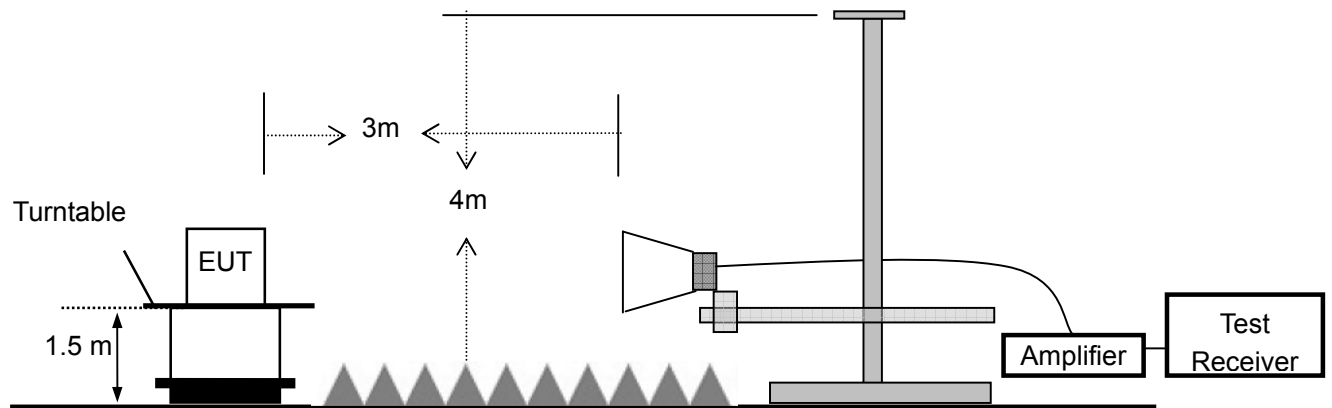

13.3 Measurement Equipment Used:

For Conducted Test

EQUIPMENT TYPE	MFR	MODEL NUMBER	SERIAL NUMBER	Characteristics	LAST CAL.	CAL DUE.
Spectrum Analyzer	Rohde & Schwarz	FSV30	1321.3008K	10Hz-30GHz	05/16/2018	05/15/2019
Coaxial Cable	CDS	79254	46107086	10Hz-30GHz	05/16/2018	05/15/2019
Antenna Connector	ARTHUR-YANG	2244-N1TG1	N/A	10Hz-30GHz	05/16/2018	05/15/2019

Remark: The temporary antenna connector is soldered on the PCB board in order to perform conducted tests and this temporary antenna connector is listed in the equipment list.

For Radiated emission Test

Item	Equipment	Manufacturer	Model No.	Serial No.	Characteristics	Last Cal.	Cal. Interval
1	Signal Analyzer	Rohde & Schwarz	FSV30	103040	9KHz-40GHz	05/16/2018	1 Year
2	Horn Antenna	Schwarzbeck	BBHA9120D	9120D-1272	1GHz-18GHz	05/16/2018	1 Year
3	Power Amplifier	LUNAR EM	LNA1G18-40	J101000000 81	1GHz-26.5GHz	05/16/2018	1 Year
4	Cable	H+S	CBL-26	N/A	1GHz-26.5GHz	05/16/2018	1 Year
5	Cable	H+S	CBL-26	N/A	1GHz-26.5GHz	05/16/2018	1 Year
6	Cable	H+S	CBL-26	N/A	1GHz-26.5GHz	05/16/2018	1 Year

13.4 Measurement Results:

Refer to attached data chart.

Spectrum Detector: PK Test Date : March 18, 2019
 Test By: Yaping Shen Temperature : 24 °C
 Test Result: PASS Humidity : 56 %

1. Conducted Test

For Non-Hopping Mode:

Frequency (MHz)	Modulation	Peak Power Output(dBm)	Result of Band edge(dBc)	Band edge Limit(dBc)
2402.03	GFSK	1.61	43.92	>20dBc
2402.06	pi/4-DQPSK	0.26	41.21	>20dBc
2402.11	8DPSK	0.19	40.39	>20dBc
2480.03	GFSK	0.89	50.35	>20dBc
2480.06	pi/4-DQPSK	-0.45	47.92	>20dBc
2480	8DPSK	-0.54	47.80	>20dBc

Test plots of GFSK

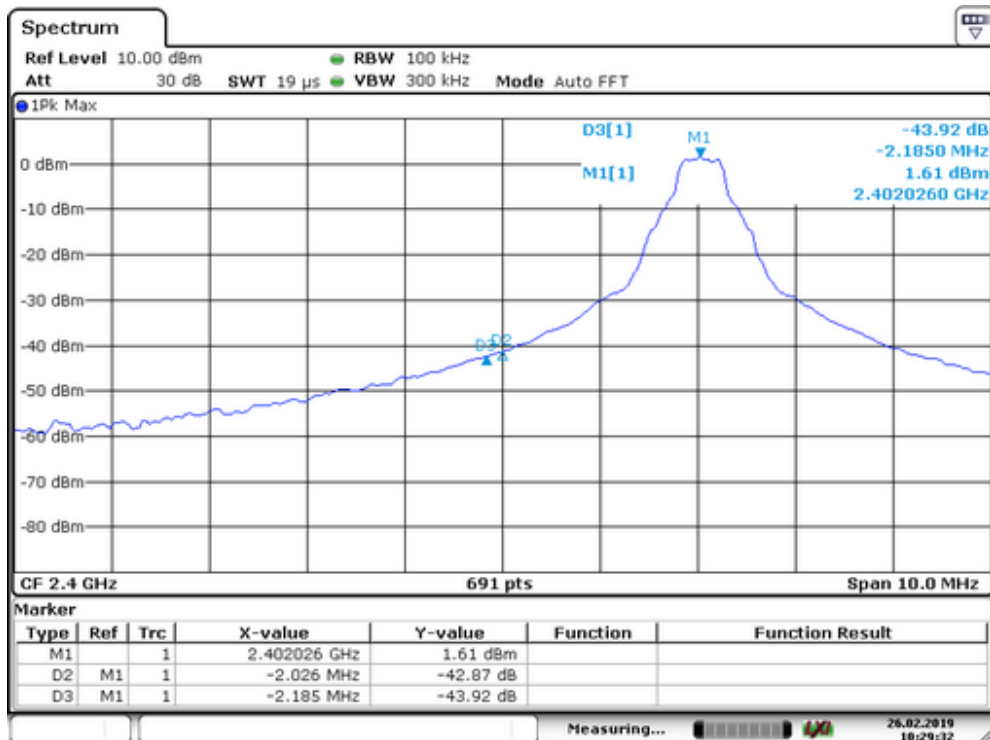

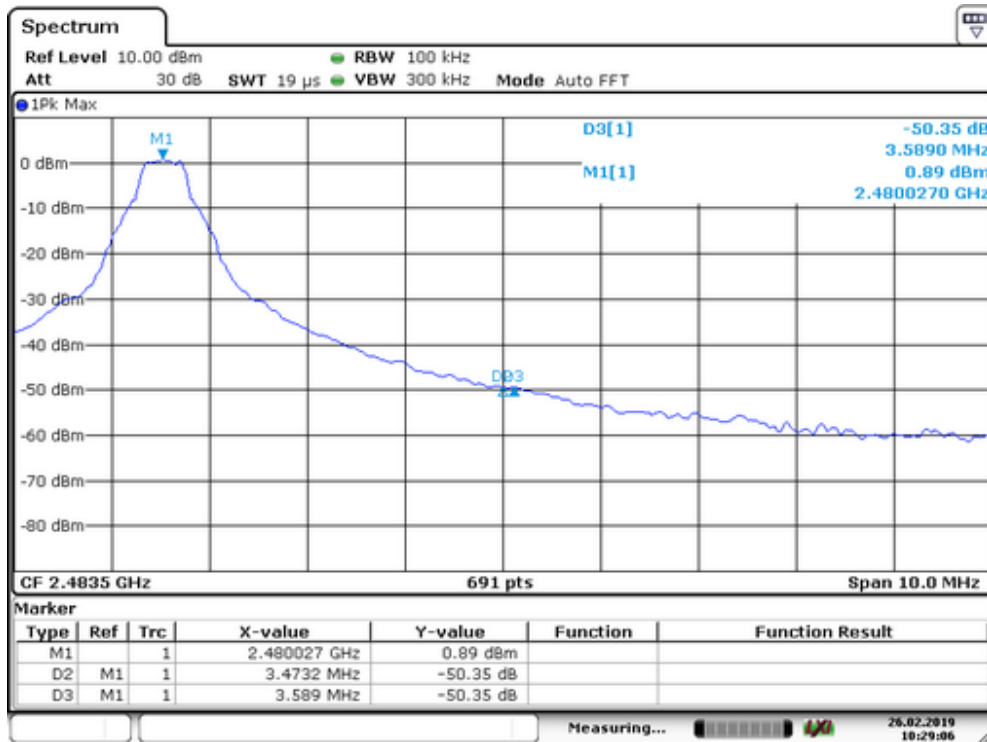

Test plots of pi/4-DQPSK

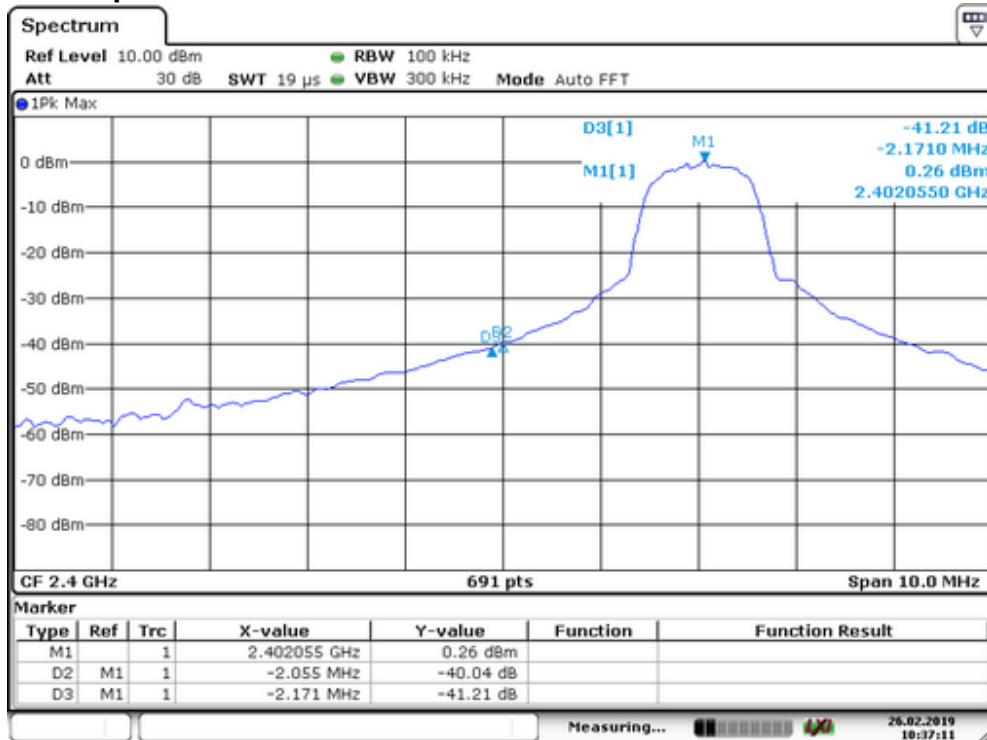

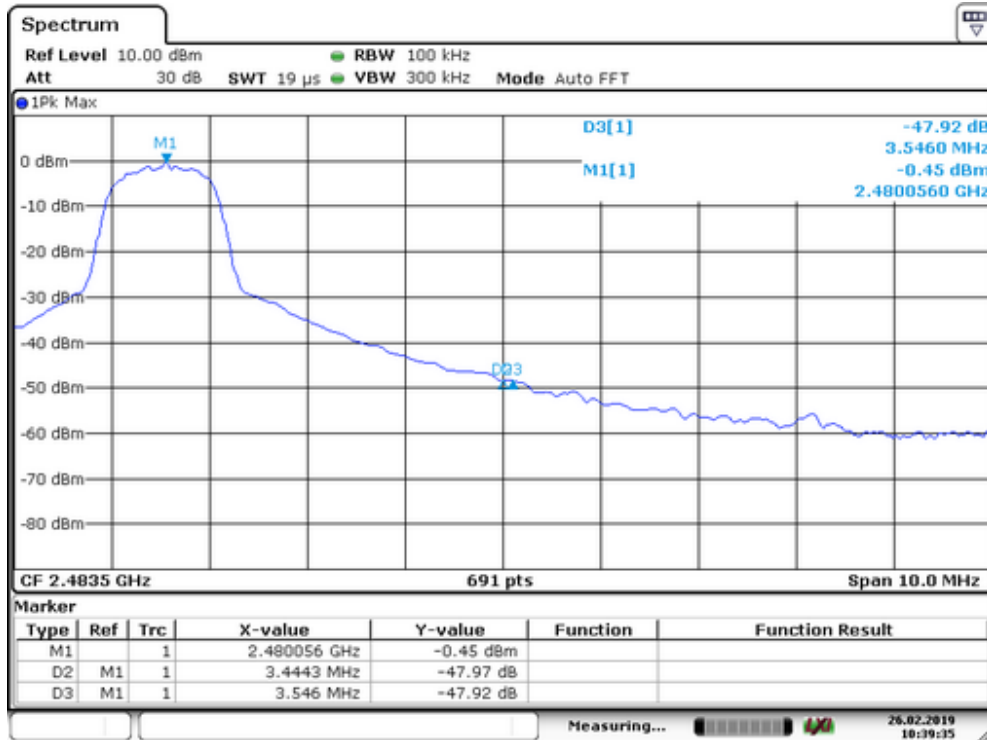

Test plots of 8DPSK

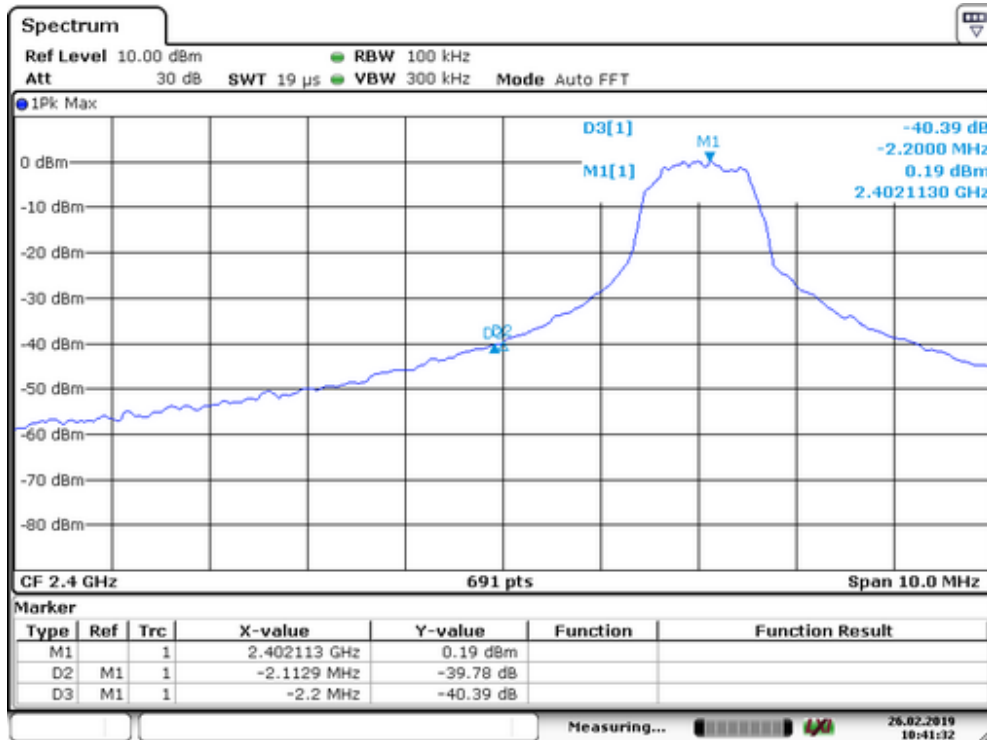

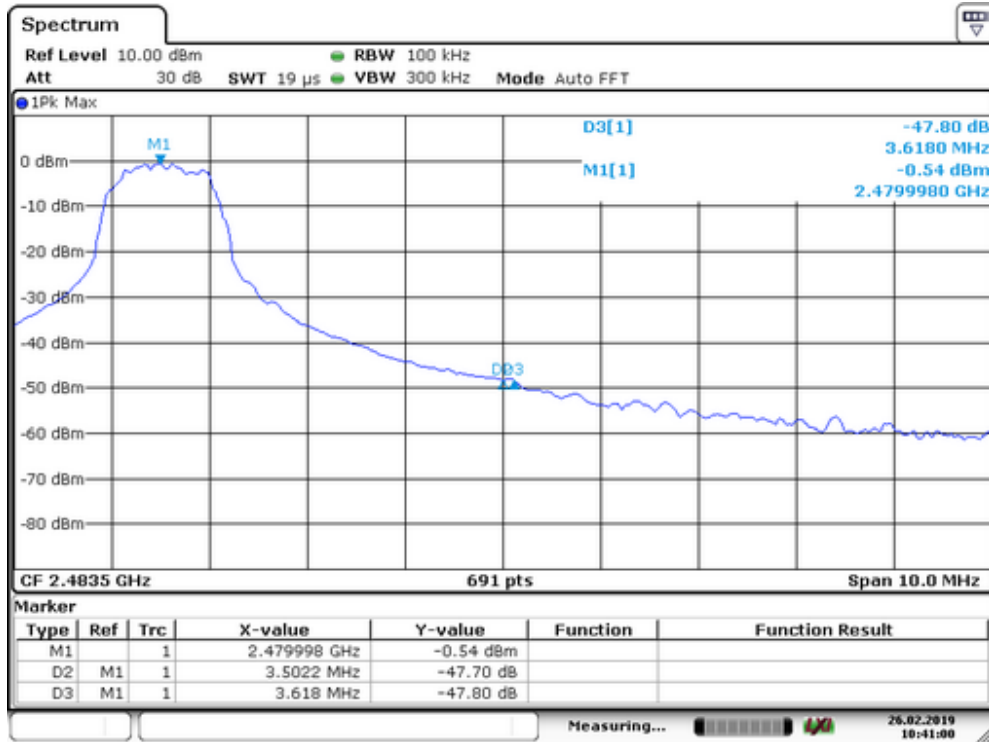

For Hopping Mode:

Frequency (MHz)	Modulation	Peak Power Output(dBm)	Result of Band edge(dBc)	Band edge Limit(dBc)
2402.03	GFSK	1.62	42.6	>20dBc
2402	pi/4-DQPSK	-0.70	48.82	>20dBc
2405	8DPSK	0.19	41.39	>20dBc
2479.09	GFSK	0.50	58.06	>20dBc
2479.09	pi/4-DQPSK	-1.16	48.85	>20dBc
2479.12	8DPSK	-4.75	57.16	>20dBc

Test plots of GFSK

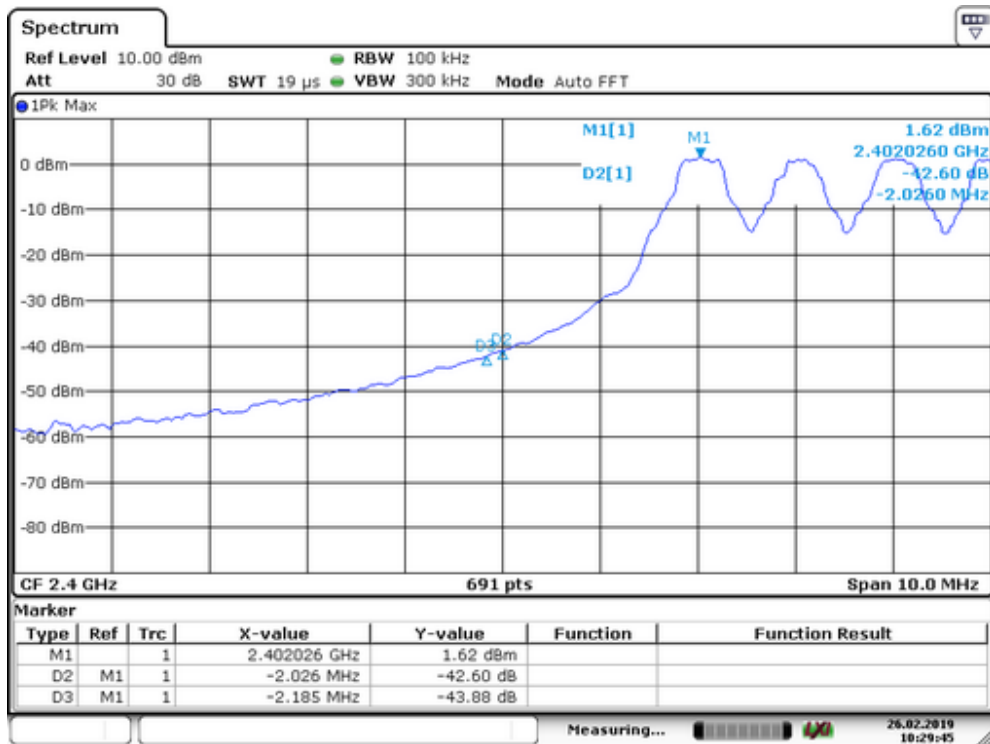

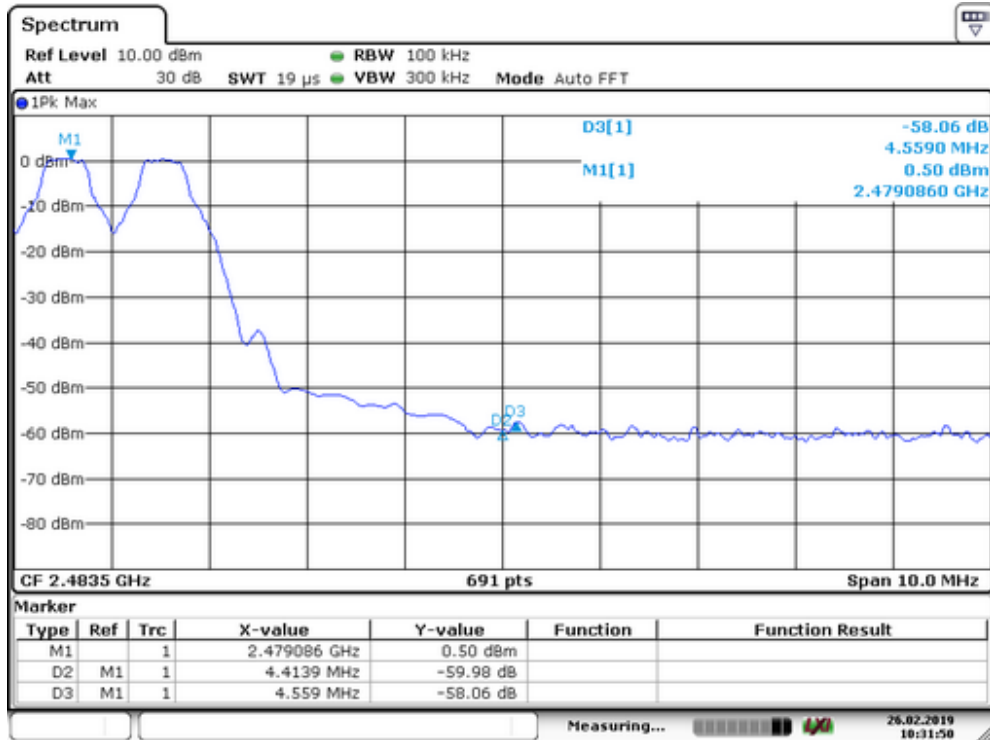

Test plots of pi/4-DQPSK

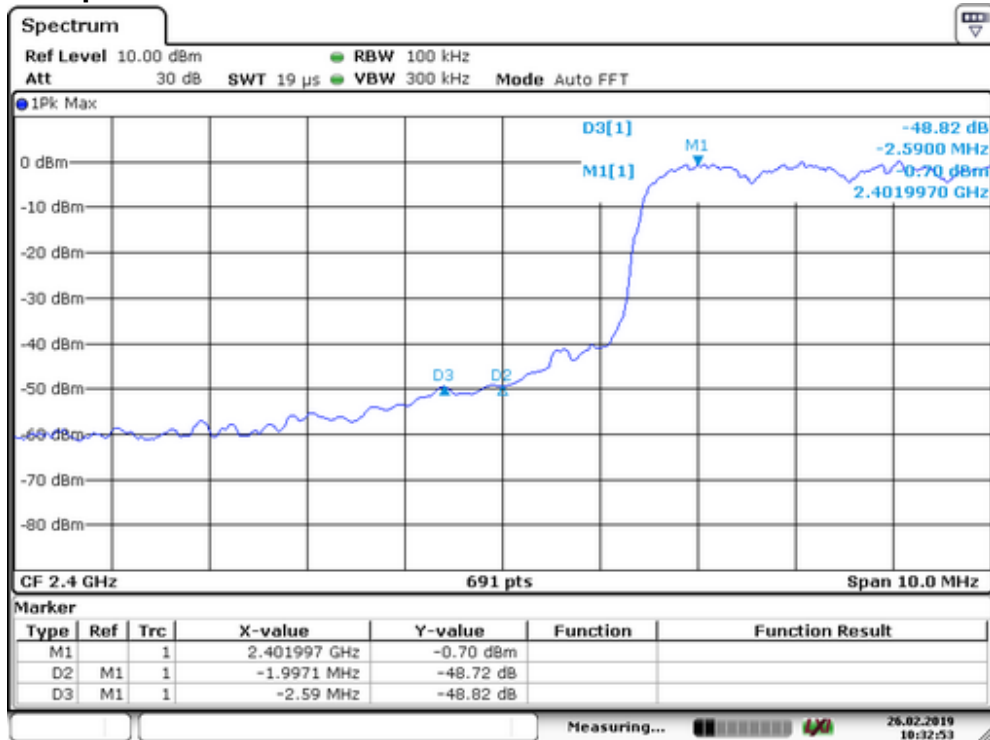

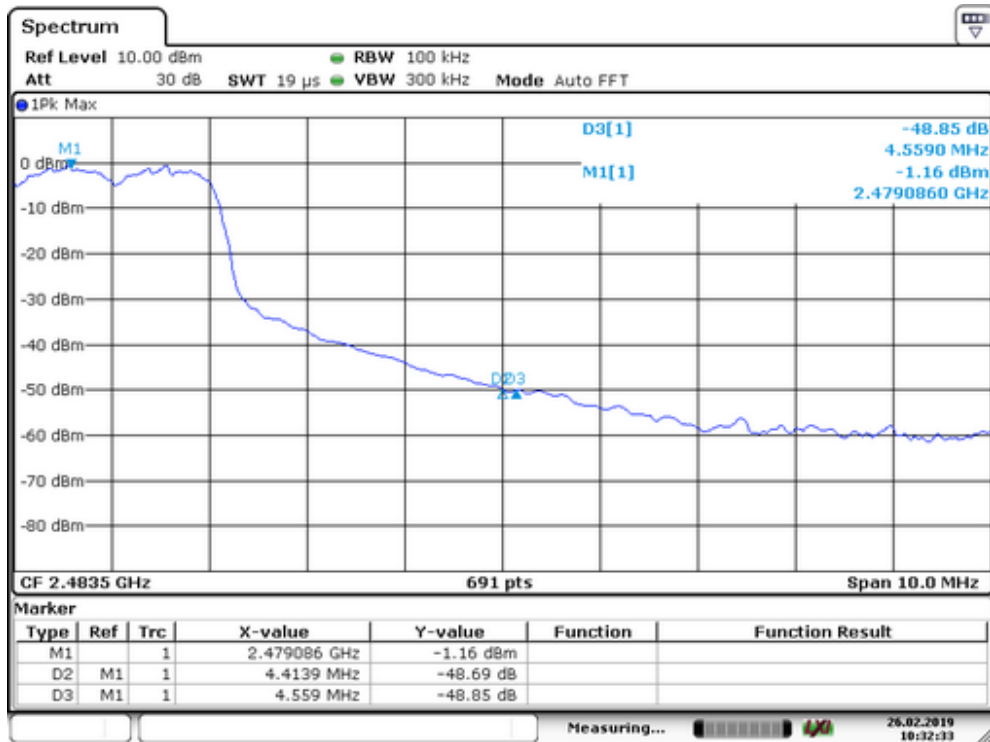

Test plots of 8DPSK

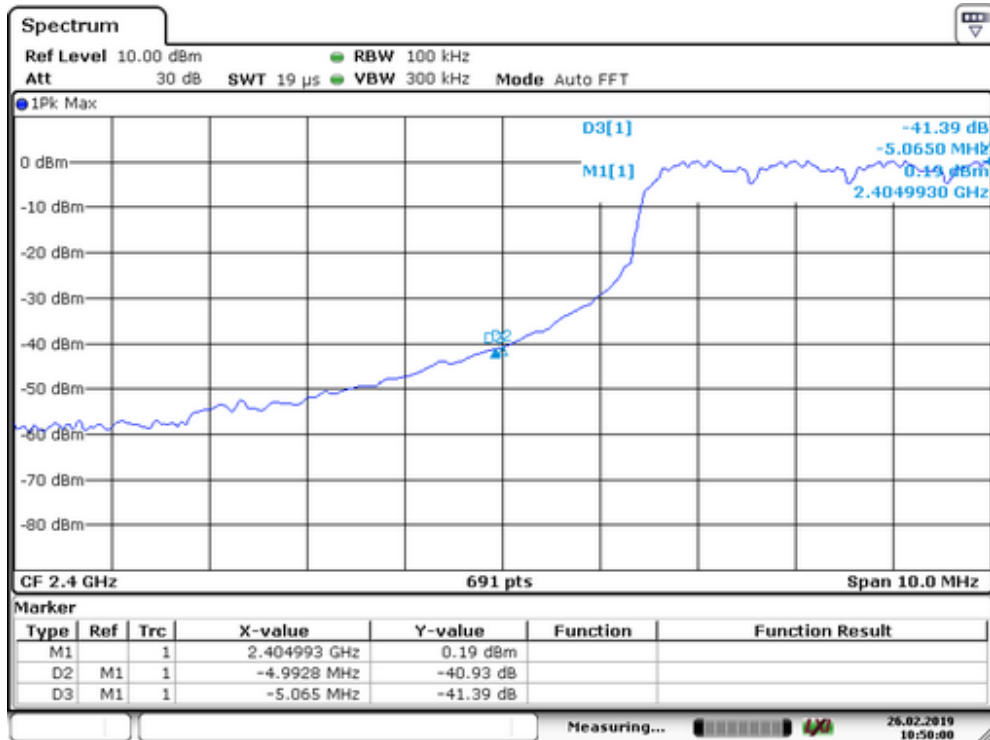

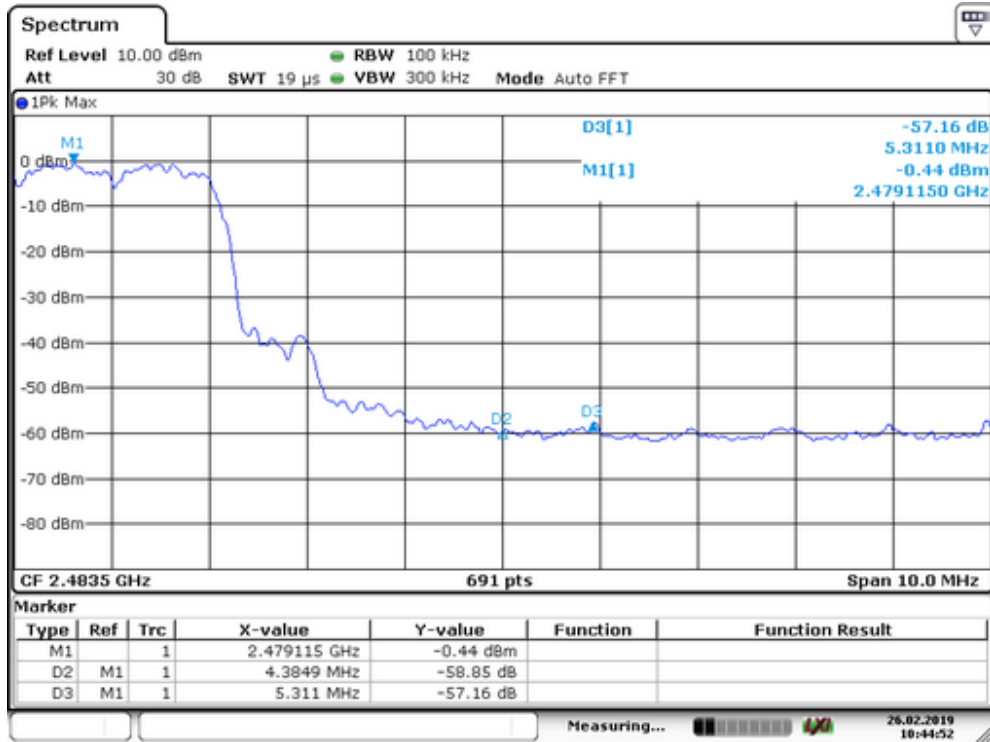

2. Radiated emission Test
Worst test modulation 8DPSK
For Non-Hopping Mode:

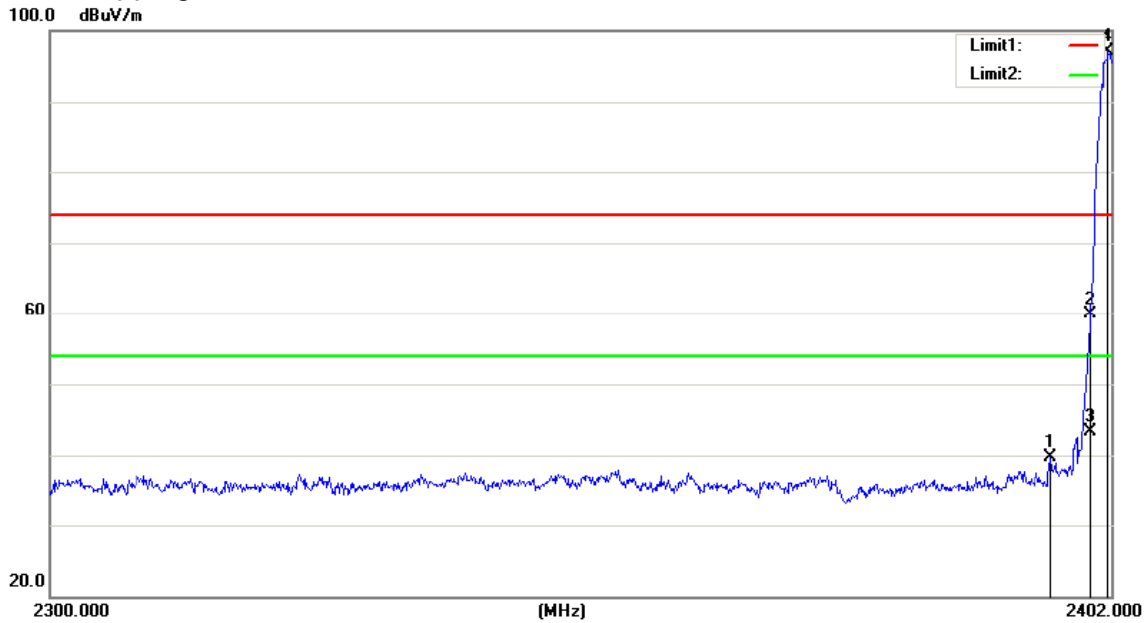

Site site #1 Polarization: **Horizontal** Temperature: 26
 Limit: (RE)FCC PART 15 C 3m_PEAK Power: Battery 3.7V Humidity: 55 %
 Mode:DSS (TX2402)
 Note:

No.	Mk.	Freq.	Reading Level	Correct Factor	Measurement	Limit	Over	Antenna Height	Table Degree	
		MHz	dBuV	dB	dBuV/m	dBuV/m	dB	cm	degree	Comment
1		2396.084	60.65	-20.95	39.70	74.00	-34.30	peak	0	
2		2400.000	80.87	-20.93	59.94	74.00	-14.06	peak	0	
3		2400.000	64.20	-20.93	43.27	54.00	-10.73	AVG	0	
4	*	2401.694	118.02	-20.93	97.09	74.00	23.09	peak	0	

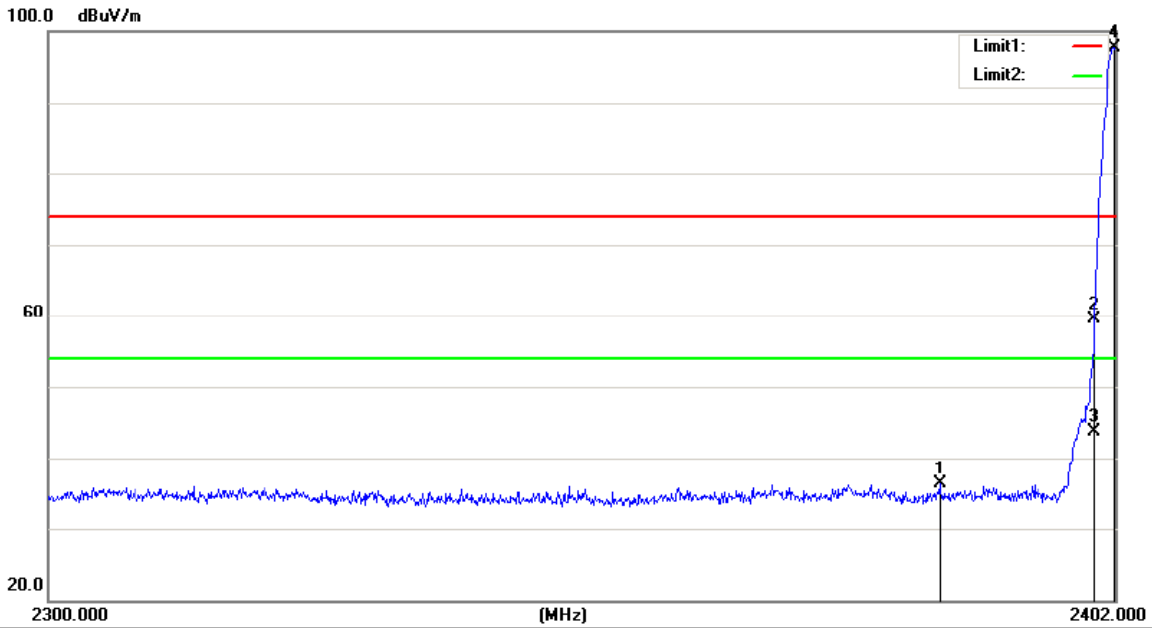

Site site #1 Polarization: **Vertical** Temperature: 26
 Limit: (RE)FCC PART 15 C 3m_PEAK Power: Battery 3.7V Humidity: 55 %
 Mode:DSS (TX2402)
 Note:

No.	Mk.	Freq. MHz	Reading Level dBuV	Correct Factor dB	Measure- ment dBuV/m	Limit dBuV/m	Over dB	Antenna Height cm	Table Degree	Comment
1		2385.068	56.15	-19.85	36.30	74.00	-37.70	peak	0	
2		2400.000	79.22	-19.77	59.45	74.00	-14.55	peak	0	
3		2400.000	63.50	-19.77	43.73	54.00	-10.27	AVG	0	
4	*	2401.898	117.48	-19.76	97.72	74.00	23.72	peak	0	

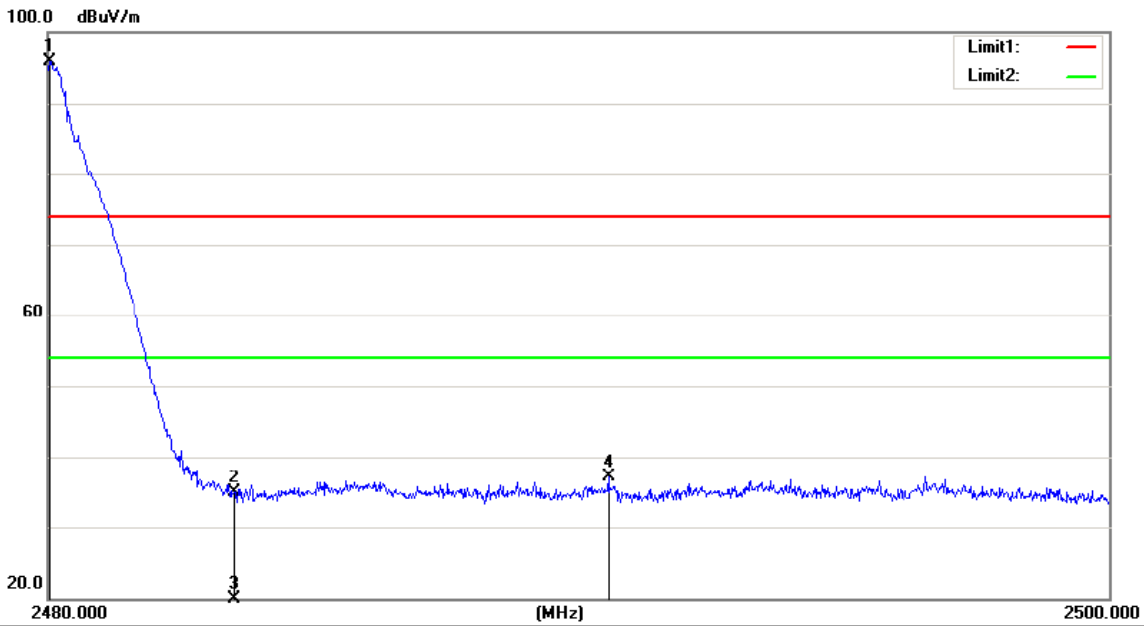

Site site #1 Polarization: **Horizontal** Temperature: 26
 Limit: (RE)FCC PART 15 C 3m_PEAK Power: Battery 3.7V Humidity: 55 %
 Mode:DSS (TX2480)
 Note:

No.	Mk.	Freq. MHz	Reading Level dBuV	Correct Factor dB	Measure- ment dBuV/m	Limit dBuV/m	Over dB	Detector	Antenna Height cm	Table Degree	Comment
1	*	2480.040	116.60	-20.71	95.89	74.00	21.89	peak		0	
2		2483.500	55.55	-20.72	34.83	74.00	-39.17	peak		0	
3		2483.500	37.15	-20.72	16.43	54.00	-37.57	AVG		0	
4		2490.540	57.78	-20.69	37.09	74.00	-36.91	peak		0	

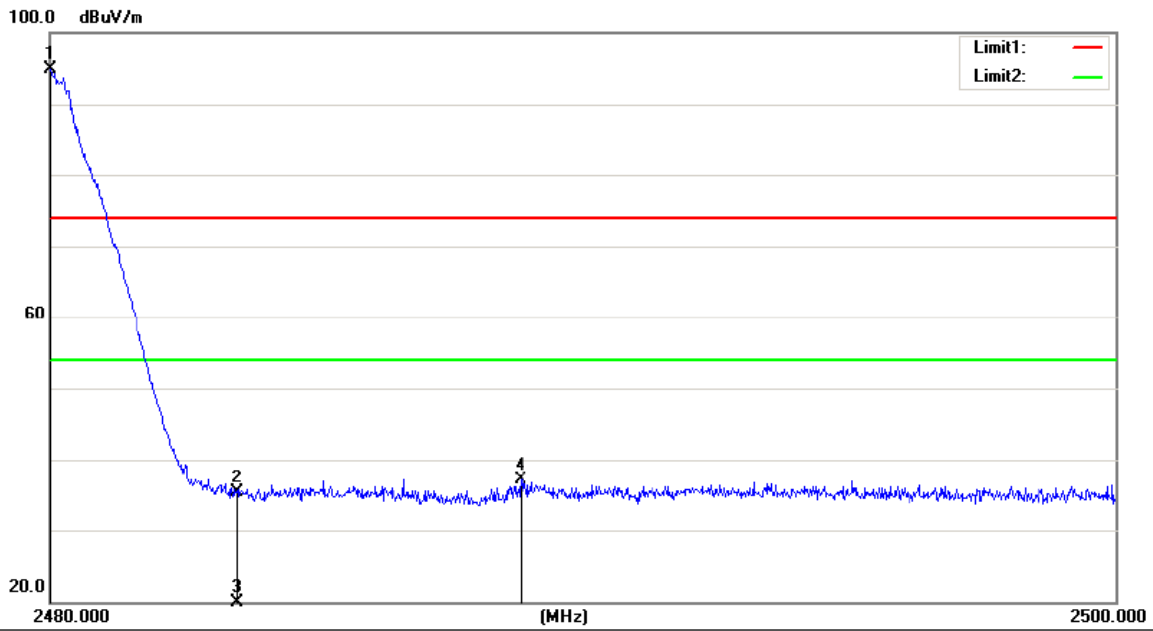

Site site #1 Polarization: **Vertical** Temperature: 26
 Limit: (RE)FCC PART 15 C 3m_PEAK Power: Battery 3.7V Humidity: 55 %
 Mode: DSS (TX2480)
 Note:

No.	Mk.	Freq. MHz	Reading Level dBuV	Correct Factor dB	Measure- ment dBuV/m	Limit dBuV/m	Over dB	Detector	Antenna Height cm	Table Degree	Comment
1	*	2480.000	114.14	-19.28	94.86	74.00	20.86	peak		0	
2		2483.500	54.62	-19.27	35.35	74.00	-38.65	peak		0	
3		2483.500	37.15	-19.27	17.88	54.00	-36.12	AVG		0	
4		2488.840	56.28	-19.23	37.05	74.00	-36.95	peak		0	

For Hopping Mode:

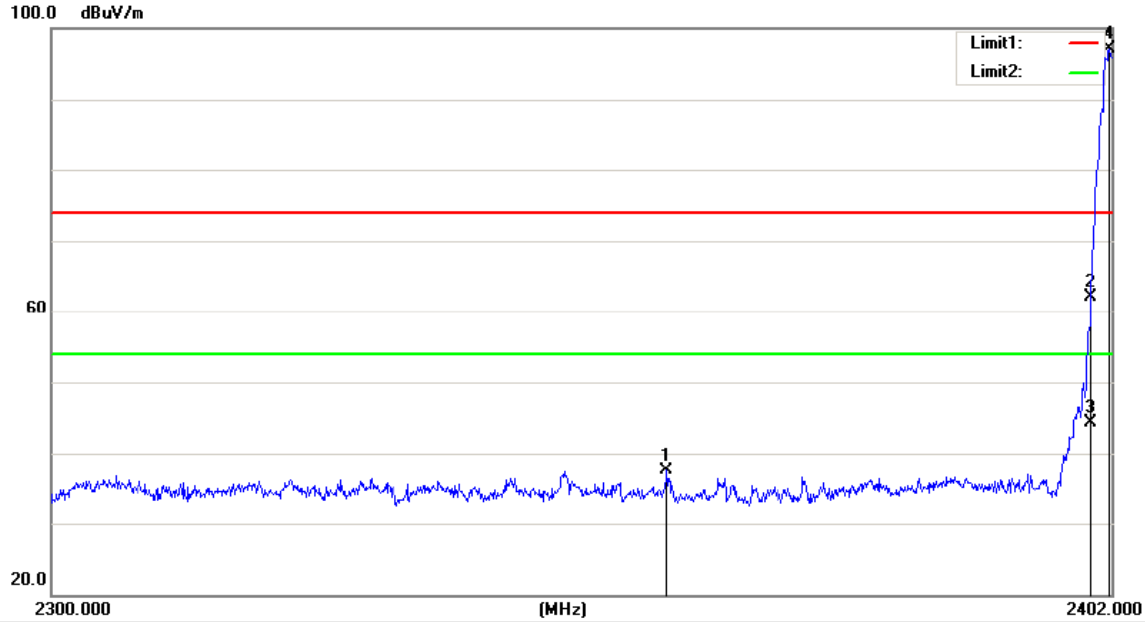

Site site #1 Polarization: **Horizontal** Temperature: 26
 Limit: (RE)FCC PART 15 C 3m_PEAK Power: Battery 3.7V Humidity: 55 %
 Mode:Hopping
 Note:

No.	Mk.	Freq.	Reading Level	Correct Factor	Measurement	Limit	Over	Antenna Height	Table Degree	
		MHz	dBuV	dB	dBuV/m	dBuV/m	dB	cm	degree	Comment
1		2358.752	58.51	-21.04	37.47	74.00	-36.53	peak	0	
2		2400.000	83.07	-20.93	62.14	74.00	-11.86	peak	0	
3		2400.000	65.32	-20.93	44.39	54.00	-9.61	AVG	0	
4	*	2401.796	118.09	-20.93	97.16	74.00	23.16	peak	0	

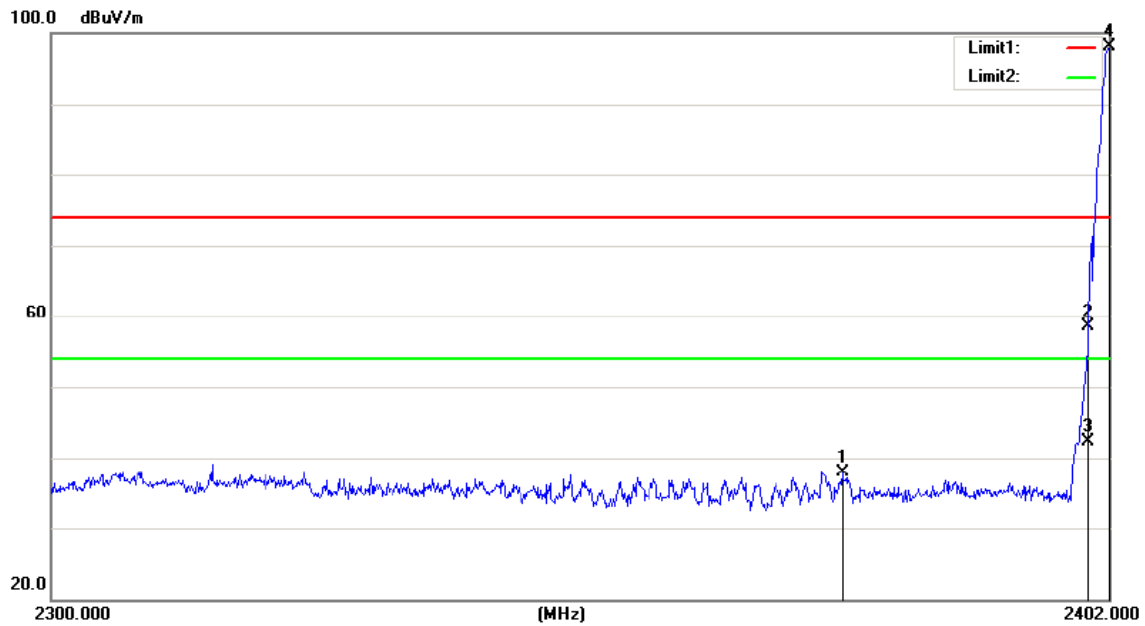

Site site #1 Polarization: *Vertical* Temperature: 26
 Limit: (RE)FCC PART 15 C 3m_PEAK Power: Battery 3.7V Humidity: 55 %
 Mode: Hopping
 Note:

No.	Mk.	Freq.	Reading Level	Correct Factor	Measurement	Limit	Over	Antenna Height	Table Degree	
		MHz	dBuV	dB	dBuV/m	dBuV/m	dB	cm	degree	Comment
1		2375.888	57.78	-19.92	37.86	74.00	-36.14	peak	0	
2		2400.000	78.22	-19.77	58.45	74.00	-15.55	peak	0	
3		2400.000	62.10	-19.77	42.33	54.00	-11.67	AVG	0	
4	*	2402.000	117.93	-19.76	98.17	74.00	24.17	peak	0	

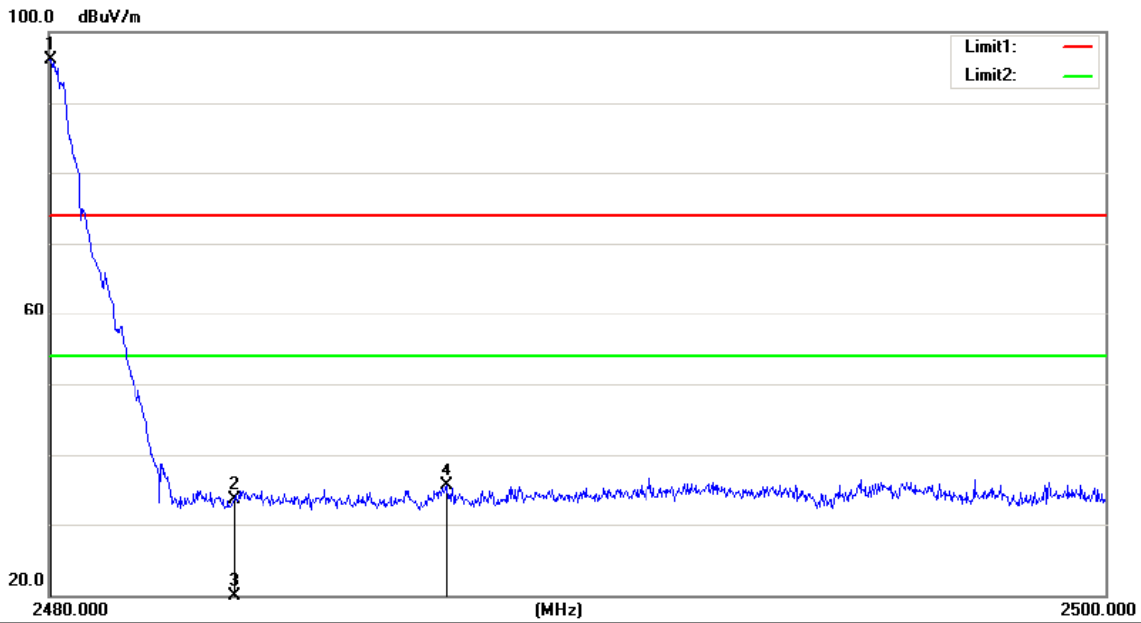

Site site #1 Polarization: **Horizontal** Temperature: 26
 Limit: (RE)FCC PART 15 C 3m_PEAK Power: Battery 3.7V Humidity: 55 %
 Mode:Hopping
 Note:

No.	Mk.	Freq. MHz	Reading Level dBuV	Correct Factor dB	Measure- ment dBuV/m	Limit dBuV/m	Over dB	Detector	Antenna Height cm	Table Degree	Comment
1	*	2480.040	116.84	-20.71	96.13	74.00	22.13	peak		0	
2		2483.500	54.27	-20.72	33.55	74.00	-40.45	peak		0	
3		2483.500	37.14	-20.72	16.42	54.00	-37.58	AVG		0	
4		2487.520	56.27	-20.70	35.57	74.00	-38.43	peak		0	

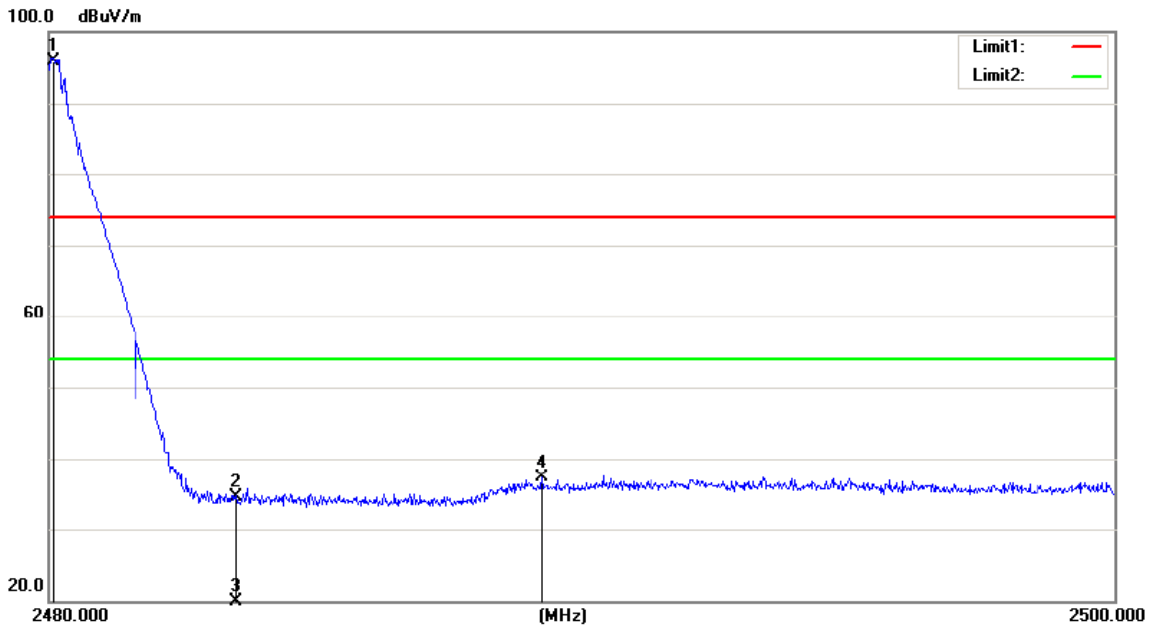

Site site #1 Polarization: **Vertical** Temperature: 26
 Limit: (RE)FCC PART 15 C 3m_PEAK Power: Battery 3.7V Humidity: 55 %
 Mode:Hopping
 Note:

No.	Mk.	Freq. MHz	Reading Level dBuV	Correct Factor dB	Measure- ment dBuV/m	Limit dBuV/m	Over dB	Detector	Antenna Height cm	Table Degree degree	Comment
1	*	2480.100	115.26	-19.28	95.98	74.00	21.98	peak		0	
2		2483.500	53.87	-19.27	34.60	74.00	-39.40	peak		0	
3		2483.500	37.14	-19.27	17.87	54.00	-36.13	AVG		0	
4		2489.260	56.46	-19.23	37.23	74.00	-36.77	peak		0	

14. Antenna Application

14.1 Antenna requirement

The EUT'S antenna is met the requirement of FCC part 15C section 15.203 and 15.247.

FCC part 15C section 15.247 requirements:

Systems operating in the 2402-2480MHz band that are used exclusively for fixed, point-to-point operations may employ transmitting antennas with directional gain greater than 6dBi provided the maximum peak output power of the intentional radiator is reduced by 1dB for every 3dB that the directional gain of the antenna exceeds 6dBi.

14.2 Result

The EUT's antenna, permanent attached antenna, used a PCB antenna and integrated on PCB, The antenna's gain is 0dBi and meets the requirement.

15. Photos of EUT

Please refer to external photos.pdf and internal photos.pdf.