



FCC TEST REPORT

REPORT NO.: RF960427A16B

MODEL NO.: CTE-650A, CTE-450A
(With Tablet Pen: EP-155E, Tablet Mouse: EC-155)

RECEIVED: Feb. 15, 2008

TESTED: Feb. 26, 2008

ISSUED: March 6, 2008

APPLICANT: PRIMAX ELECTRONICS LTD.

ADDRESS: No. 669, Ruey Kuang Road, Neihu, Taipei,
Taiwan, R.O.C.

ISSUED BY: Advance Data Technology Corporation

LAB ADDRESS: No. 47, 14th Ling, Chia Pau Tsuen, Lin Kou
Hsiang 244, Taipei Hsien, Taiwan, R.O.C.

This test report consists of 24 pages in total. It may be duplicated completely for legal use with the approval of the applicant. It should not be reproduced except in full, without the written approval of our laboratory. The client should not use it to claim product endorsement by TAF, A2LA or any government agencies. The test results in the report only apply to the tested sample.





Table of Contents

1	CERTIFICATION	3
2	SUMMARY OF TEST RESULTS.....	4
2.1	MEASUREMENT UNCERTAINTY	4
3	GENERAL INFORMATION	5
3.1	GENERAL DESCRIPTION OF EUT	5
3.1	DESCRIPTION OF TEST MODES	6
3.1.1	CONFIGURATION OF SYSTEM UNDER TEST	6
3.1.2	TEST MODE APPLICABILITY AND TESTED CHANNEL DETAIL:	7
3.2	GENERAL DESCRIPTION OF APPLIED STANDARDS	8
3.3	DESCRIPTION OF SUPPORT UNITS	8
4	TEST PROCEDURE AND RESULT	9
4.1	CONDUCTED EMISSION MEASUREMENT	9
4.1.1	LIMITS OF CONDUCTED EMISSION MEASUREMENT	9
4.1.2	TEST INSTRUMENTS	9
4.1.3	TEST PROCEDURES	10
4.1.4	DEVIATION FROM TEST STANDARD	10
4.1.5	TEST SETUP	11
4.1.6	EUT OPERATING CONDITIONS	11
4.1.7	TEST RESULTS	12
4.2	RADIATED EMISSION MEASUREMENT	14
4.2.1	LIMITS OF RADIATED EMISSION MEASUREMENT	14
4.2.2	TEST INSTRUMENT	15
4.2.3	TEST PROCEDURE	16
4.2.4	DEVIATION FROM TEST STANDARD	16
4.2.5	TEST SETUP	17
4.2.6	EUT OPERATING CONDITION	17
4.2.7	TEST RESULT	18
4.2.8	TEST RESULTS (SPECTRUM BANDWIDTH)	20
5	PHOTOGRAPHS OF THE TEST CONFIGURATION	21
6	INFORMATION ON THE TESTING LABORATORIES	23
7	APPENDIX A – MODIFICATIONS RECORDERS FOR ENGINEERING CHANGES TO THE EUT BY THE LAB.....	24



1 CERTIFICATION

PRODUCT: PEN TABLET
BRAND NAME: WACOM
MODEL NO: CTE-650A, CTE-450A
(With Tablet Pen: EP-155E, Tablet Mouse: EC-155)
APPLICANT: PRIMAX ELECTRONICS LTD.
TEST SAMPLE: ENGINEERING SAMPLE
TESTED: Feb. 26, 2008
STANDARDS: FCC Part 15, Subpart C (Section 15.209),
ANSI C63.4 -2003

The above equipment (Model: CTE-650A) has been tested by **Advance Data Technology Corporation**, and found compliance with the requirement of the above standards. The test record, data evaluation & Equipment Under Test (EUT) configurations represented herein are true and accurate accounts of the measurements of the sample's EMC characteristics under the conditions specified in this report.

PREPARED BY : Annie Chang , **DATE:** March 6, 2008
(Annie Chang / Senior Specialist)

TECHNICAL ACCEPTANCE : Jamison Chan , **DATE:** March 6, 2008
Responsible for RF (Jamison Chan / Senior Engineer)

APPROVED BY : Ken Liu , **DATE:** March 6, 2008
(Ken Liu / Deputy Manager)

2 SUMMARY OF TEST RESULTS

The EUT has been tested according to the following specifications:

APPLIED STANDARD: FCC Part 15, Subpart C			
STANDARD PARAGRAPH	TEST TYPE	RESULT	REMARK
15.207	Conducted Emission Test	PASS	Minimum passing margin is -12.26dB at 0.193MHz
15.209	Radiated Emission Test	PASS	Minimum passing margin is -3.39dB at 177.735MHz

2.1 MEASUREMENT UNCERTAINTY

Where relevant, the following measurement uncertainty levels have been estimated for tests performed on the EUT as specified in CISPR 16-4-2:

This uncertainty represents an expanded uncertainty expressed at approximately the 95% confidence level using a coverage factor of k=2.

Measurement	Frequency	Uncertainty
Conducted emissions	9kHz ~ 30MHz	2.44 dB
Radiated emissions	30MHz ~ 1GHz	3.75 dB
	1GHz ~ 40GHz	2.89 dB

3 GENERAL INFORMATION

3.1 GENERAL DESCRIPTION OF EUT

PRODUCT	PEN TABLET
MODEL NO.	CTE-650A, CTE-450A (With Tablet Pen: EP-155E, Tablet Mouse: EC-155)
FCC ID	EMJTCTE-450
POWER SUPPLY	5.0Vdc from host equipment
CARRIER FREQUENCY OF EACH CHANNEL	750KHz +/- 10 %
NUMBER OF CHANNEL	1
ANTENNA TYPE	Integral antenna
DATA CABLE	Shielded USB cable (1.5m)
I/O PORTS	USB port
ASSOCIATED DEVICES	N/A

NOTE:

1. This report is a supplementary report of the original one (ADT report No.: RF960427A16) issued on May 22, 2007 to verify test result for some electronic and mechanical changes. The main changes were sensor board difference, change USB cable and additional model.
2. The EUT is the ideal tool to enhance user's presentations and documents. The pen (Model: EP-155E) and the mouse (Model: EC-155) will be sold together with the EUT.
3. This report is prepared for FCC class II permissive change.
4. The EUT has two models, which are identical to each other except for outer appearance differences only, as follows:

Model No.	Differences
CTE-650A	outer appearance differences
CTE-450A	

After pre-tested both models, found **model: CTE-650A** was the worst, therefore only its test data was recorded in this report.

5. For a more detailed features description, please refer to the manufacturer's specifications or the User's Manual.

3.1 DESCRIPTION OF TEST MODES

The EUT was pre-tested with its two models (CTE-650A, CTE-450A) under following two conditions:

- ◆ with the pen
- ◆ with the mouse

And found the worst emission was under **Model: CTE-650A with the pen**, therefore only this mode was applied for final test.

One channel was provided to this EUT

Channel	Frequency (Hz)
1	750KHz

3.1.1 CONFIGURATION OF SYSTEM UNDER TEST

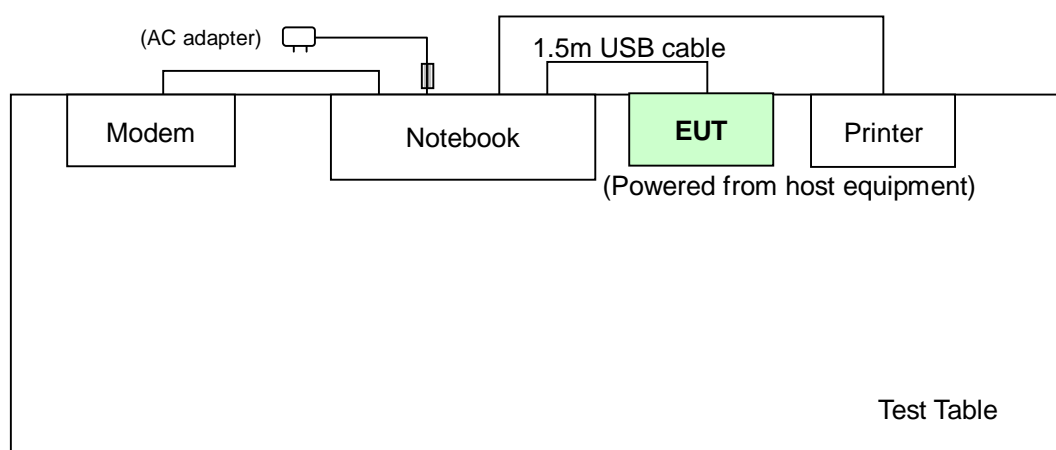

3.1.2 TEST MODE APPLICABILITY AND TESTED CHANNEL DETAIL:

EUT configure mode	Applicable to		Description
	PLC	RE<1G	
-	√	√	NA

Where PLC: Power Line Conducted Emission RE<1G RE: Radiated Emission below 1GHz

Power Line Conducted Emission Test:

Following channel(s) was (were) selected for the final test as listed below.

Available Channel	Tested Channel	Modulation Type
1	1	FSK

Radiated Emission Test (Below 1 GHz):

Following channel(s) was (were) selected for the final test as listed below.

Available Channel	Tested Channel	Modulation Type
1	1	FSK

3.2 GENERAL DESCRIPTION OF APPLIED STANDARDS

The EUT is a RF product. According to the specifications of the manufacturer, it must comply with the requirements of the following standards:

FCC Part 15, Subpart C. (15.209)
ANSI C63.4 -2003

All test items have been performed and recorded as per the above standards.

3.3 DESCRIPTION OF SUPPORT UNITS

The EUT has been tested as an independent unit together with other necessary accessories or support units. The following support units or accessories were used to form a representative test configuration during the tests.

NO.	PRODUCT	BRAND	MODEL NO.	SERIAL NO.	FCC ID
1	NOTEBOOK COMPUTER	DELL	PP05L	20375526736	FCC DoC Approved
2	PRINTER	EPSON	LQ-300+	DCGY017054	FCC DoC Approved
3	MODEM	ACEEX	1414	980020520	IFAXDM1414

NO.	SIGNAL CABLE DESCRIPTION OF THE ABOVE SUPPORT UNITS
1	N/A
2	1.8m braid shielded wire, terminated with DB25 and Centronics connector via metallic frame, w/o core
3	1.2 m braid shielded wire, terminated with DB25 and DB9 connector via metallic frame, w/o core.

NOTE: All power cords of the above support units are non-shielded (1.8m).

4 TEST PROCEDURE AND RESULT

4.1 CONDUCTED EMISSION MEASUREMENT

4.1.1 LIMITS OF CONDUCTED EMISSION MEASUREMENT

FREQUENCY OF EMISSION (MHz)	CONDUCTED LIMIT (dB μ V)	
	Quasi-peak	Average
0.15-0.5	66 to 56	56 to 46
0.5-5	56	46
5-30	60	50

- NOTE:**
1. The lower limit shall apply at the transition frequencies.
 2. The limit decreases in line with the logarithm of the frequency in the range of 0.15 to 0.50 MHz.
 3. All emanations from a class A/B digital device or system, including any network of conductors and apparatus connected thereto, shall not exceed the level of field strengths specified above.

4.1.2 TEST INSTRUMENTS

DESCRIPTION & MANUFACTURER	MODEL NO.	SERIAL NO.	CALIBRATED UNTIL
ROHDE & SCHWARZ Test Receiver	ESCS 30	838251/021	Dec. 19, 2008
ROHDE & SCHWARZ Artificial Mains Network (for EUT)	ESH3-Z5	100218	Nov. 20, 2008
LISN With Adapter (for EUT)	AD10	C10Ada-001	Nov. 21, 2008
ROHDE & SCHWARZ Artificial Mains Network (for peripherals)	ESH3-Z5	100219	Nov. 08, 2008
ROHDE & SCHWARZ Artificial Mains Network (for peripherals)	ESH3-Z5	894785/020	Jun. 27, 2008
Software	ADT_Cond_V7.3.5	NA	NA
Software	ADT_ISN_V7.3.5	NA	NA
RF cable (JYEBAO)	5D-FB	Cable-C10.01	Feb. 26, 2009
SUHNTER Terminator (For ROHDE & SCHWARZ LISN)	65BNC-5001	E1-010773	Feb. 13, 2009

- NOTE:**
1. The calibration interval of the above test instruments is 12 months and the calibrations are traceable to NML/ROC and NIST/USA.
 2. The test was performed in ADT Shielded Room No. 10.
 3. The VCCI Site Registration No. C-1852.

4.1.3 TEST PROCEDURES

- a. The EUT was placed 0.4 meters from the conducting wall of the shielded room with EUT being connected to the power mains through a line impedance stabilization network (LISN). Other support units were connected to the power mains through another LISN. The two LISNs provide 50 ohm/ 50uH of coupling impedance for the measuring instrument.
- b. Both lines of the power mains connected to the EUT were checked for maximum conducted interference.
- c. The frequency range from 150kHz to 30MHz was searched. Emission levels under (Limit - 20dB) was not recorded.

4.1.4 DEVIATION FROM TEST STANDARD

No deviation

4.1.5 TEST SETUP

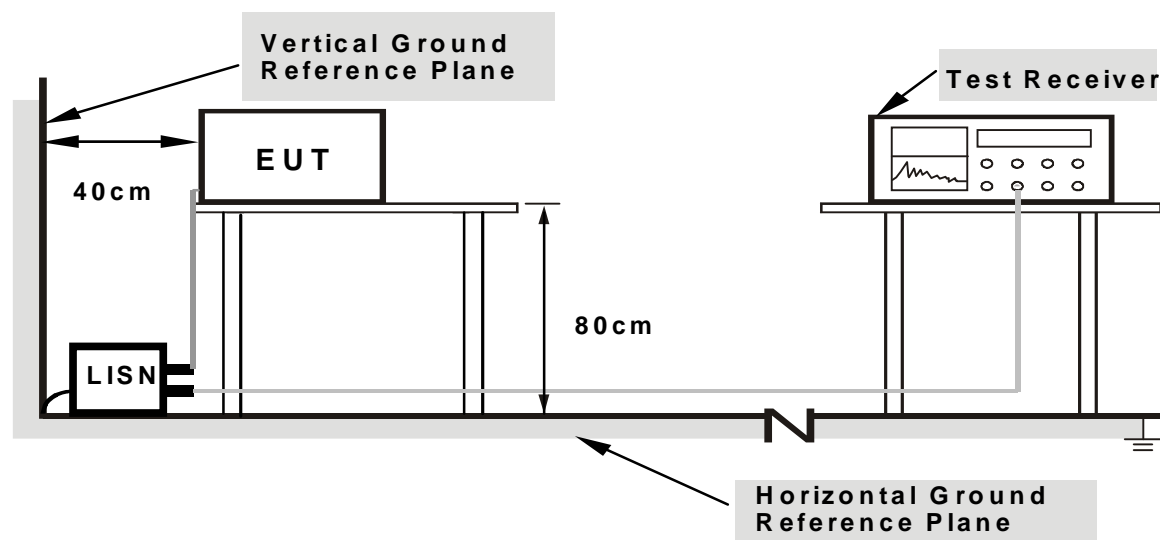

- Note:**
1. Support units were connected to second LISN.
 2. Both of LISNs (AMN) are 80cm from EUT and at least 80cm from other units and other metal planes support units.

For the actual test configuration, please refer to the related item – Photographs of the Test Configuration.

4.1.6 EUT OPERATING CONDITIONS

- a. Turn on the power of all equipment.
- b. Connected the PEN TABLET (EUT) with a Notebook on the testing table.
- c. The PEN TABLET (EUT) sent messages to Notebook via a USB cable.
- d. The Notebook sent "H" messages to LCD panel and displayed "H" patterns on its screen.
- e. The Notebook sent messages to modem.
- f. The Notebook sent messages to printer and the printer printed them out.
- g. Repeated c ~ g.

4.1.7 TEST RESULTS

INPUT POWER (SYSTEM)	120Vac, 60 Hz	6dB BANDWIDTH	9 kHz
ENVIRONMENTAL CONDITIONS	22deg. C, 67% RH, 1006hPa	PHASE	Line 1
TESTED BY	Jun Wu		

No	Freq. [MHz]	Corr. Factor (dB)	Reading Value		Emission Level		Limit		Margin	
			[dB (uV)]		[dB (uV)]		[dB (uV)]		(dB)	
			Q.P.	AV.	Q.P.	AV.	Q.P.	AV.	Q.P.	AV.
1	0.173	0.22	43.74	-	43.96	-	64.79	54.79	-20.83	-
2	0.193	0.22	51.43	-	51.65	-	63.91	53.91	-12.26	-
3	2.035	0.38	26.59	-	26.97	-	56.00	46.00	-29.03	-
4	3.813	0.45	22.13	-	22.58	-	56.00	46.00	-33.42	-
5	10.904	0.84	30.32	-	31.16	-	60.00	50.00	-28.84	-
6	20.253	1.42	30.42	-	31.84	-	60.00	50.00	-28.16	-

- REMARKS:**
1. Q.P. and AV. are abbreviations of quasi-peak and average individually.
 2. "-": The Quasi-peak reading value also meets average limit and measurement with the average detector is unnecessary.
 3. The emission levels of other frequencies were very low against the limit.
 4. Margin value = Emission level - Limit value
 5. Correction factor = Insertion loss + Cable loss
 6. Emission Level = Correction Factor + Reading Value.

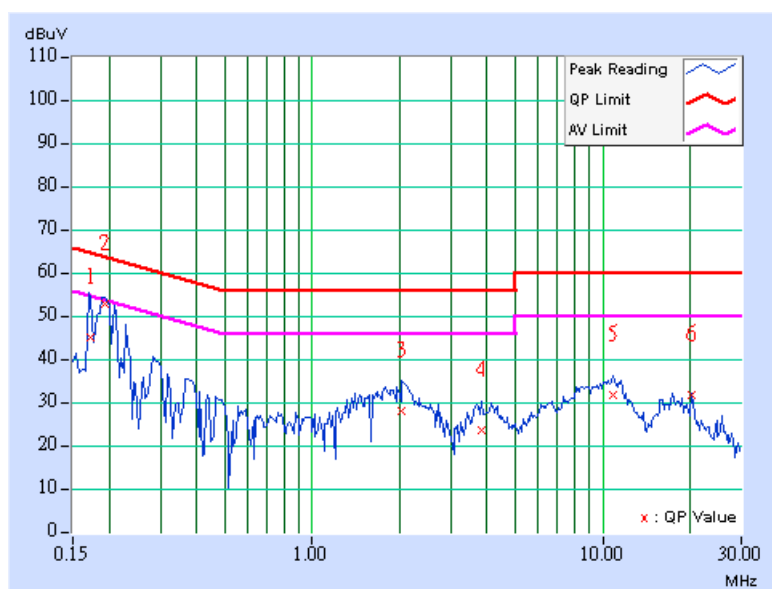

INPUT POWER (SYSTEM)	120Vac, 60 Hz	6dB BANDWIDTH	9 kHz
ENVIRONMENTAL CONDITIONS	22deg. C, 67% RH, 1006hPa	PHASE	Line 2
TESTED BY	Jun Wu		

No	Freq. [MHz]	Corr. Factor (dB)	Reading Value [dB (uV)]		Emission Level [dB (uV)]		Limit [dB (uV)]		Margin (dB)	
			Q.P.	AV.	Q.P.	AV.	Q.P.	AV.	Q.P.	AV.
			1	0.154	0.22	51.23	-	51.45	-	65.79
2	0.193	0.22	51.37	-	51.59	-	63.91	53.91	-12.32	-
3	1.402	0.35	26.40	-	26.75	-	56.00	46.00	-29.25	-
4	4.168	0.45	23.38	-	23.83	-	56.00	46.00	-32.17	-
5	7.754	0.58	25.49	-	26.07	-	60.00	50.00	-33.93	-
6	10.301	0.69	29.91	-	30.60	-	60.00	50.00	-29.40	-

- REMARKS:**
1. Q.P. and AV. are abbreviations of quasi-peak and average individually.
 2. "-": The Quasi-peak reading value also meets average limit and measurement with the average detector is unnecessary.
 3. The emission levels of other frequencies were very low against the limit.
 4. Margin value = Emission level - Limit value
 5. Correction factor = Insertion loss + Cable loss
 6. Emission Level = Correction Factor + Reading Value.

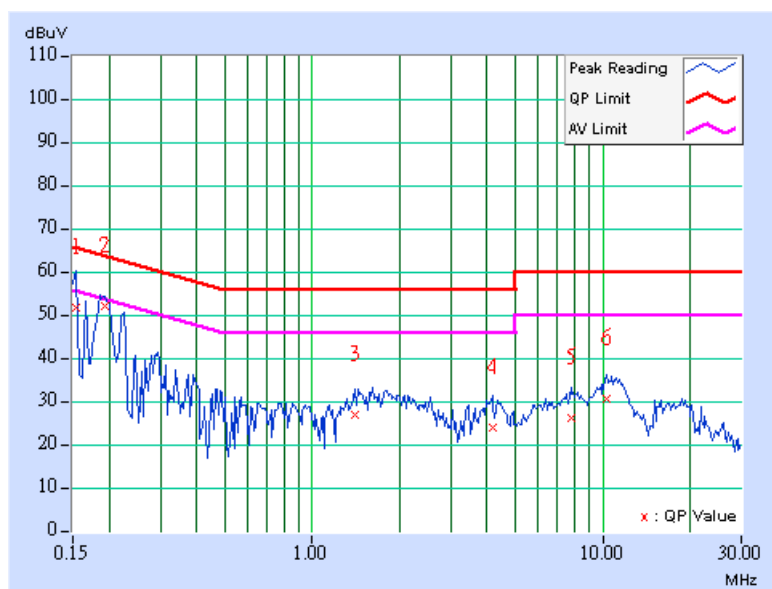

4.2 RADIATED EMISSION MEASUREMENT

4.2.1 LIMITS OF RADIATED EMISSION MEASUREMENT

FOR FREQUENCY BELOW 30MHz

FREQUENCY (MHz)	FIELD STRENGTH (dBuV/m)		MEASUREMENT DISTANCE (meters)
	uV/m	dBuV/m	
0.009 – 0.490	2400 / F (kHz)	48.52-13.80	300
0.490 – 1.705	24000 / F (kHz)	33.80-22.97	30
1.705 – 30.0	30	29.54	30

BETWEEN 30-1000MHz

FREQUENCY (MHz)	Class A (at 10m)		Class B (at 3m)	
	uV/m	dBuV/m	uV/m	dBuV/m
30-88	90	39.1	100	40.0
88-216	150	43.5	150	43.5
216-960	210	46.4	200	46.0
Above 960	300	49.5	500	54.0

FOR FREQUENCY ABOVE 1000MHz

FREQUENCY (MHz)	Class A (at 10m)		Class B (at 3m)	
	PEAK	AVERAGE	PEAK	AVERAGE
Above 1000	80.0	60.0	74.0	54.0

- Note: (1) The lower limit shall apply at the transition frequencies.
 (2) Emission level (dBuV/m) = 20 log Emission level (uV/m).
 (3) All emanation from a class A/B digital device or system, including any network of conductors and apparatus connected thereto, shall not exceed the level of fieldstrengths specified above.



4.2.2 TEST INSTRUMENT

DESCRIPTION & MANUFACTURER	MODEL NO.	SERIAL NO.	CALIBRATED UNTIL
HP Preamplifier	8447D	2432A03504	May 09, 2008
HP Preamplifier	8449B	3008A01201	Oct. 01, 2008
HP Preamplifier	8449B	3008A01292	Aug. 05, 2008
ROHDE & SCHWARZ TEST RECEIVER	ESI7	836697/012	Dec. 05, 2008
Schwarzbeck Antenna	VULB 9168	137	Sep. 13, 2008
Schwarzbeck Antenna	VHBA 9123	480	Apr. 18, 2008
ADT. Turn Table	TT100	0306	NA
ADT. Tower	AT100	0306	NA
Software	ADT_Radiated_V 7.6.15	NA	NA
SUHNER RF cable	SF104-26.5	CABLE-CH6-17m-01	Nov. 04, 2008
ROHDE & SCHWARZ Spectrum Analyzer	FSP 40	100036	Mar. 13, 2008
Loop Antenna R & S	HFH2-Z2	100070	Jan. 13, 2009

- NOTE:**
1. The calibration interval of the above test instruments is 12 months. And the calibrations are traceable to NML/ROC and NIST/USA.
 2. The horn antenna and HP preamplifier (model: 8449B) are used only for the measurement of emission frequency above 1GHz if tested.
 3. The test was performed in ADT Chamber No. 6.
 4. The Industry Canada Reference No. IC 3789-6.

4.2.3 TEST PROCEDURE

- a. The EUT was placed on the top of a rotating table 0.8 meters above the ground at a 3 meter semi-anechoic chamber. The table was rotated 360 degrees to determine the position of the highest radiation.
- b. The EUT was set 3 meters away from the interference-receiving antenna, which was mounted on the top of a variable-height antenna tower.
- c. The antenna's height is varied from one meter to four meters above the ground to determine the maximum value of the field strength. Both horizontal and vertical polarizations of the antenna are set to make the measurement.
- d. For each suspected emission, the EUT was arranged to its worst case and then the antenna was tuned to heights from 1 meter to 4 meters and the rotatable table was turned from 0 degrees to 360 degrees to find the maximum reading.
- e. The test-receiver system was set to Peak Detect Function and Specified Bandwidth with Maximum Hold Mode.
- f. If the emission level of the EUT in peak mode was lower than the limit specified, then testing could be stopped and the peak values of the EUT would be reported. Otherwise the emissions would be re-tested one by one using peak, quasi-peak method or average method as specified and then reported in data sheet.
- g. For measurement of frequency above 1000 MHz, the EUT was set 3 meters away from the interference antenna and the detect function was set to Peak or Average.

4.2.4 DEVIATION FROM TEST STANDARD

No deviation

4.2.5 TEST SETUP

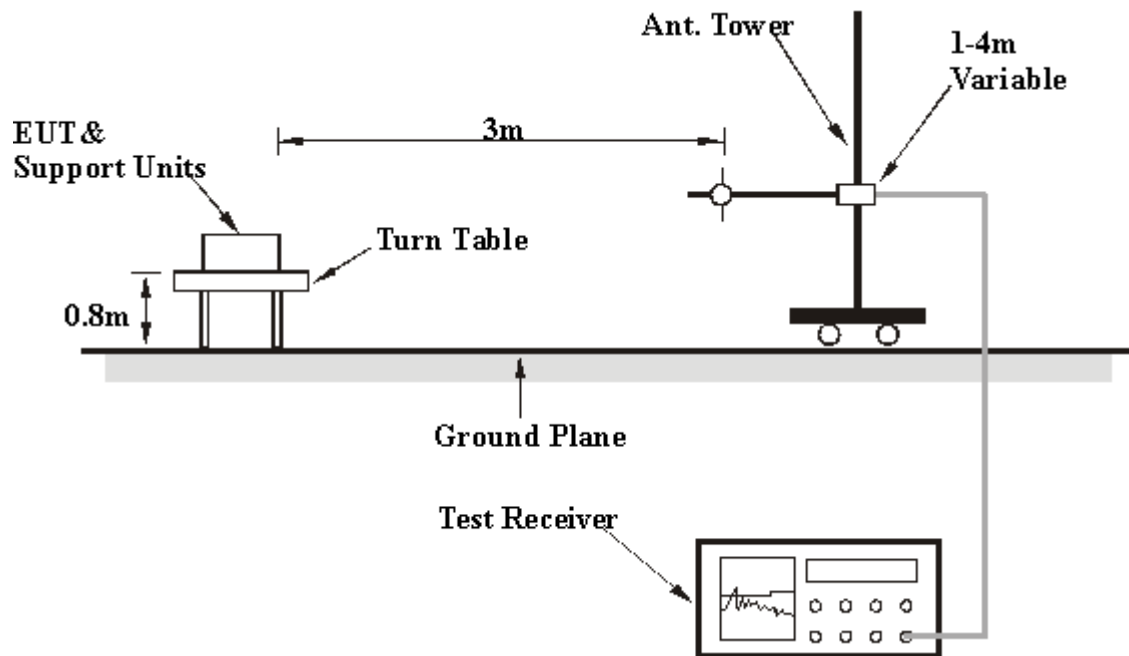

For the actual test configuration, please refer to the related item in this test report - Photographs of the Test Configuration.

4.2.6 EUT OPERATING CONDITION

Same as item 4.1.6.

4.2.7 TEST RESULT

INPUT POWER (SYSTEM)	120Vac, 60 Hz	FREQUENCY RANGE	9 kHz ~ 30 MHz
ENVIRONMENTAL CONDITIONS	18deg. C, 75% RH, 1006hPa	DETECTOR FUNCTION	Quasi-Peak
TESTED BY	Jun Wu		

TEST DISTANCE: 3 M								
No.	Freq. (MHz)	Emission Level (dBuV/m)	Limit (dBuV/m)	Margin (dB)	Antenna Height (m)	Table Angle (Degree)	Raw Value (dBuV)	Correction Factor (dB/m)
1	0.750	48.70 QP	70.10	-21.40	1.00	0	29.61	19.09
2	2.250	43.85 QP	69.54	-25.69	1.00	0	24.60	19.25
3	3.750	41.40 QP	69.54	-28.14	1.00	0	22.08	19.32
4	5.250	40.07 QP	69.54	-29.47	1.00	0	20.79	19.28
5	6.750	36.69 QP	69.54	-32.85	1.00	0	17.46	19.23
6	8.250	31.65 QP	69.54	-37.89	1.00	0	12.46	19.19
7	9.750	28.15 QP	69.54	-41.39	1.00	0	8.91	19.24

- REMARKS:**
1. Emission level(dBuV/m)=Raw Value(dBuV) + Correction Factor(dB/m)
 2. Correction Factor(dB/m) = Antenna Factor (dB/m) + Cable Factor (dB)
 3. The other emission levels were very low against the limit.
 4. Margin value = Emission level – Limit value.
 5. Above limits have been translated by the formula
 6. Loop antenna was used for all radiated emission below 30MHz.

The measured field strength was extrapolated to distance 30 meters, using the formula that the limit of field strength varies as the inverse distance square (40dB per decade of distance)

Example:

24000/750KHz	=32 uV/m	30m
	=30.10 dBuV/m	30m
	=30.10+40log(30/3)	3m
	=70.10 dBuV/m	

INPUT POWER (SYSTEM)	120Vac, 60 Hz	FREQUENCY RANGE	30-1000MHz
ENVIRONMENTAL CONDITIONS	18deg. C, 75% RH, 1006hPa	DETECTOR FUNCTION	Quasi-Peak
TESTED BY	Jun Wu		

ANTENNA POLARITY & TEST DISTANCE: HORIZONTAL AT 3 M

No.	Freq. (MHz)	Emission Level (dBuV/m)	Limit (dBuV/m)	Margin (dB)	Antenna Height (m)	Table Angle (Degree)	Raw Value (dBuV)	Correction Factor (dB/m)
1	133.026	30.92 QP	43.50	-12.58	1.36 H	145	17.77	13.15
2	173.848	30.33 QP	43.50	-13.17	1.32 H	103	17.44	12.89
3	267.154	34.42 QP	46.00	-11.58	1.28 H	127	19.21	15.21
4	416.834	31.38 QP	46.00	-14.62	1.29 H	91	11.76	19.62
5	733.687	31.69 QP	46.00	-14.31	1.22 H	103	4.91	26.78
6	799.780	31.07 QP	46.00	-14.93	1.15 H	28	2.84	28.23
7	900.862	33.68 QP	46.00	-12.32	1.08 H	325	4.46	29.22

ANTENNA POLARITY & TEST DISTANCE: VERTICAL AT 3 M

No.	Freq. (MHz)	Emission Level (dBuV/m)	Limit (dBuV/m)	Margin (dB)	Antenna Height (m)	Table Angle (Degree)	Raw Value (dBuV)	Correction Factor (dB/m)
1	49.439	35.30 QP	40.00	-4.70	1.00 V	10	22.00	13.30
2	115.531	35.02 QP	43.50	-8.48	1.00 V	241	22.07	12.96
3	177.735	40.11 QP	43.50	-3.39	1.00 V	10	26.82	13.29
4	199.118	31.25 QP	43.50	-12.25	1.00 V	16	19.40	11.85
5	249.659	33.30 QP	46.00	-12.70	1.00 V	220	18.50	14.80
6	531.523	36.84 QP	46.00	-9.16	1.05 V	238	13.81	23.03
7	900.862	33.97 QP	46.00	-12.03	1.32 V	235	4.75	29.22

- REMARKS:**
1. Emission level(dBuV/m)=Raw Value(dBuV) + Correction Factor(dB/m)
 2. Correction Factor(dB/m) = Antenna Factor (dB/m) + Cable Factor (dB)
 3. The other emission levels were very low against the limit.
 4. Margin value = Emission level – Limit value.

4.2.8 TEST RESULTS (SPECTRUM BANDWIDTH)

750 KHz

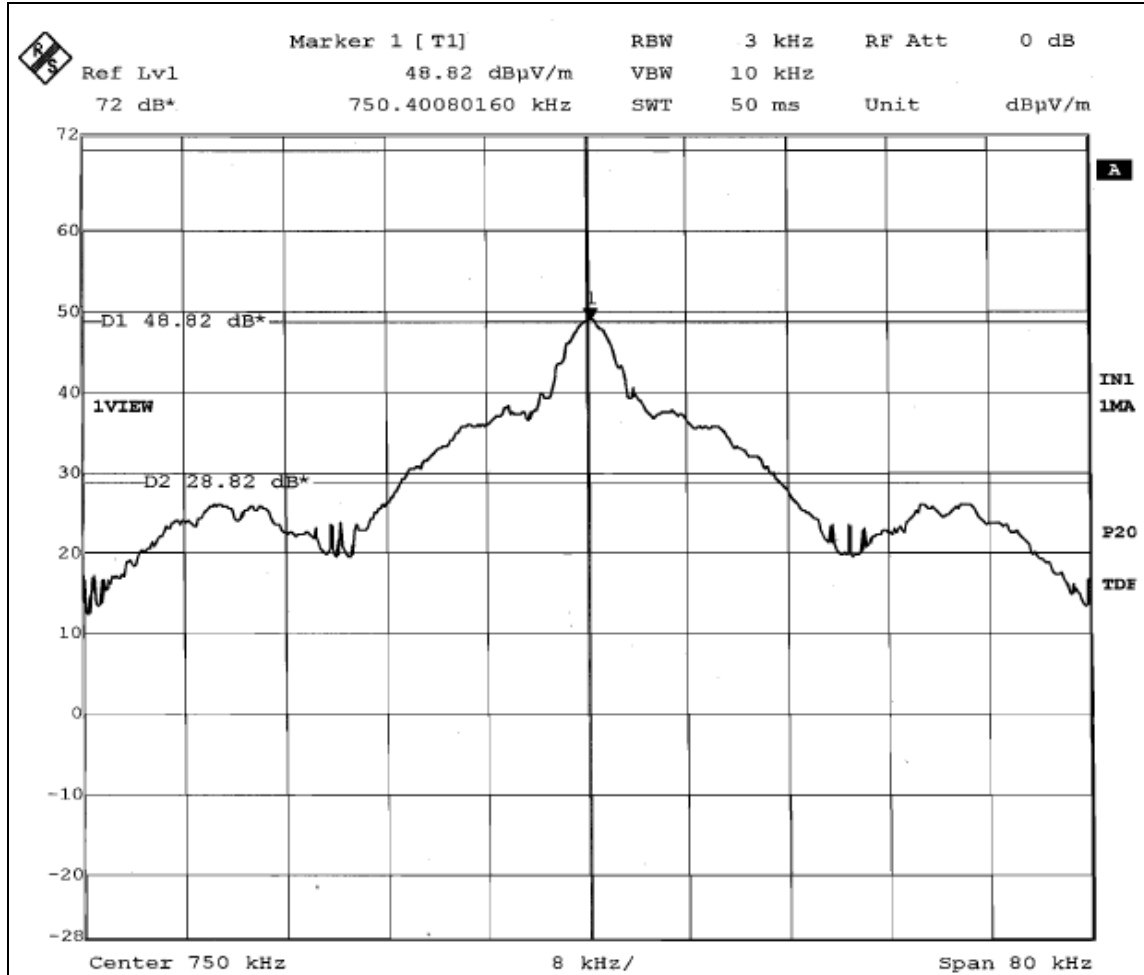

5 PHOTOGRAPHS OF THE TEST CONFIGURATION

CONDUCTED EMISSION TEST



RADIATED EMISSION TEST





6 INFORMATION ON THE TESTING LABORATORIES

We, ADT Corp., were founded in 1988 to provide our best service in EMC, Radio, Telecom and Safety consultation. Our laboratories are accredited and approved by the following approval agencies according to ISO/IEC 17025

USA	FCC, UL, A2LA
Germany	TUV Rheinland
Japan	VCCI
Norway	NEMKO
Canada	INDUSTRY CANADA, CSA
R.O.C.	TAF, BSMI, NCC
Netherlands	Telefication
Singapore	GOST-ASIA(MOU)
Russia	CERTIS(MOU)

Copies of accreditation certificates of our laboratories obtained from approval agencies can be downloaded from our web site: www.adt.com.tw/index.5/phtml.
If you have any comments, please feel free to contact us at the following:

Linko EMC/RF Lab:
Tel: 886-2-26052180
Fax: 886-2-26051924

Hsin Chu EMC/RF Lab:
Tel: 886-3-5935343
Fax: 886-3-5935342

Hwa Ya EMC/RF/Safety/Telecom Lab:
Tel: 886-3-3183232
Fax: 886-3-3185050

Web Site: www.adt.com.tw

The address and road map of all our labs can be found in our web site also.

7 APPENDIX A – MODIFICATIONS RECORDERS FOR ENGINEERING CHANGES TO THE EUT BY THE LAB

No any modifications are made to the EUT by the lab during the test.