

REV.	DESCRIPTION	ENG.	APPROVAL
2	0版未承認	Wing.Liang 2018/8/14	Apple.Zhao Sarah.Lee

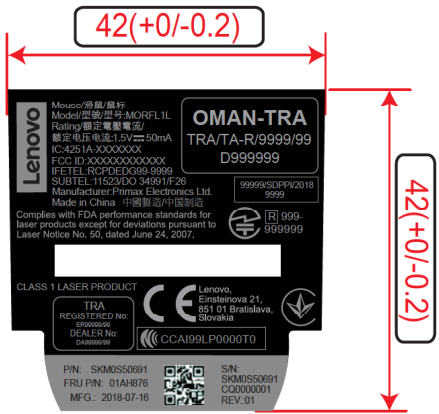

1:1

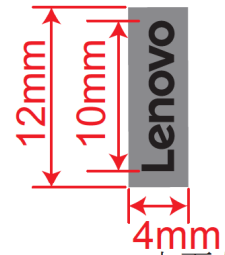

Lenovo logo 上下左右居中央列印

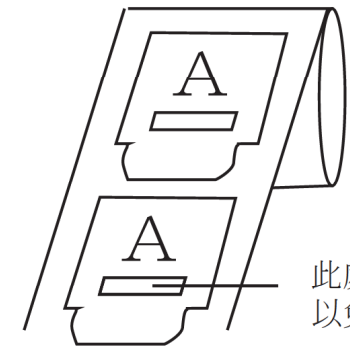

此處方型區域標籤來料需保留
以免列印機感應不了標籤

空白標籤成卷來料, 如上圖

Notes:

1. 標籤顏色: 黑底灰字(Pantone cool gray 11C)
2. 標籤印刷內容上下, 左右居中列印
3. Dimension 為 IQC 和廠商必檢尺寸, 尺寸單位: mm
4. 普通壓克力膠, T=0.03mm, 粘著力: 3.0kg/cm²
5. Requirement of Primax Part:
 1. Comply with Primax QW-5Q002"Green Product Chemical Substances Specification"
 2. Follow customer's specification as required
 3. Follow Halogen- Free requirement : Br<900 ppm, Cl<900 ppm, Br+Cl< 1500 ppm if required.
6. PRODUCT MUST BE HALOGEN FREE

DO NOT SCALE DRAWING THESE DRAWINGS AND SPECIFICATIONS ARE THE PROPERTY OF PRIMAX ELECTRONICS LTD. AND SHALL NOT BE REPRODUCED, COPIED OR USED IN ANY MANNER WITHOUT THE PRIOR WRITTEN CONSENT OF PRIMAX ELECTRONICS LTD. UNLESS OTHERWISE SPECIFIED, DIMENSIONS ARE IN MILLIMETERS AND TOLERANCE: ±1.0mm	PRIMAX 致伸資訊電子有限公司 PRIMAX ELECTRONICS LTD.			
	USED	Lenovo	APPD.	Sarah.Lee
	FINISH	背膠	CHKD.	Apple.Zhao
	SCALE	/	UNIT	m/m
	DR.		Wing.Liang 2018/6/28	
TITLE		FCC LABEL		
MATERIAL		80P合成紙+OPP膜		
DWG NO.		30401193200A		
FILE NAME		30401193200A	SH EET	1/1
SIZE		A4		
REV.		2		

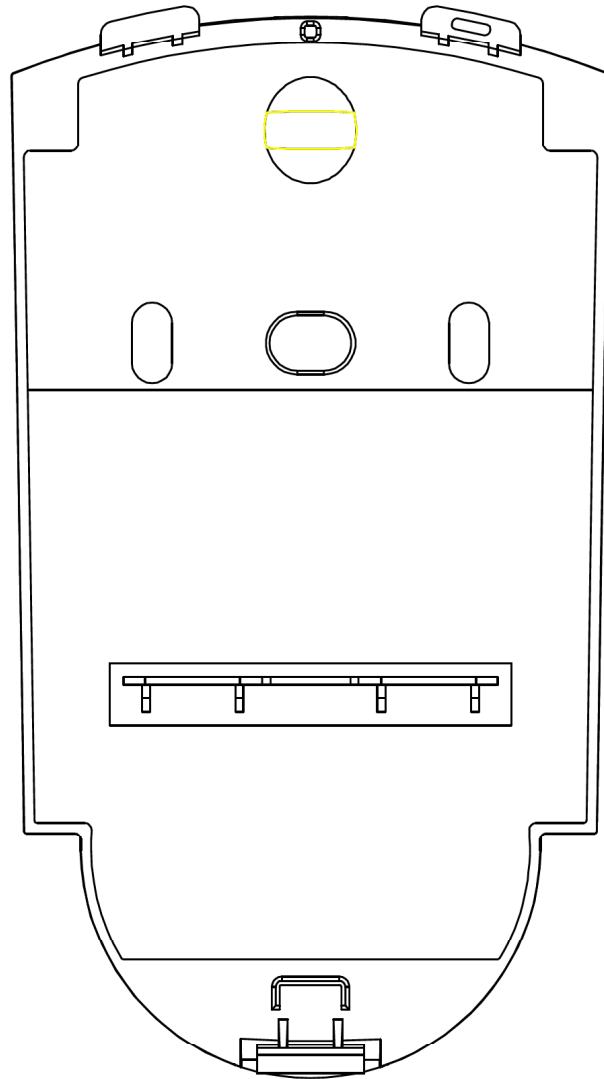

刻字

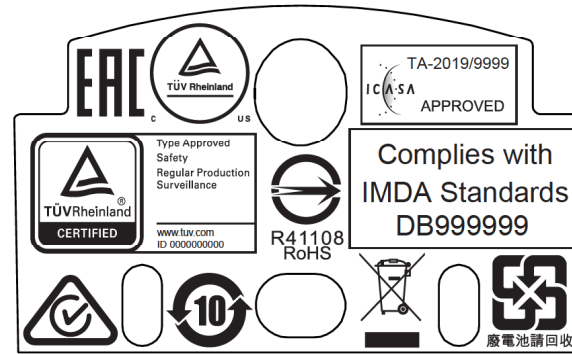

比例1:1

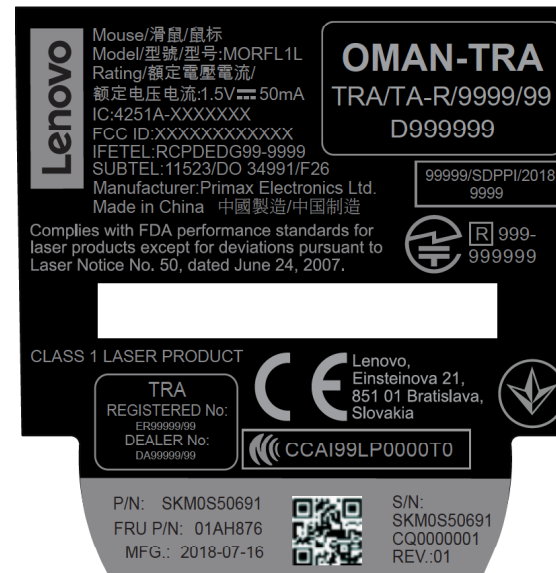

Label