

***lenovo***

# Lenovo Combined Mouse User Guide

 <http://www.lenovo.com/safety>

**Note:** Before installing the product, be sure to read the warranty information in Appendix B “Lenovo Limited Warranty” on page 17.

**9th Edition(February 2012)**

**© Copyright Lenovo 2005, 2011.**

LIMITED AND RESTRICTED RIGHTS NOTICE: If data or software is delivered pursuant a General Services Administration “GSA” contract, use, reproduction, or disclosure is subject to restrictions set forth in Contract No. GS-35F-05925.

---

# Contents

<b>About this user guide . . . . .</b>	<b>iii</b>	<b>Appendix A. Service and Support . . .</b>	<b>15</b>
<b>Chapter 1. Lenovo and ThinkPad mice . . . . .</b>	<b>1</b>	Online technical support . . . . .	15
Product description . . . . .	1	Telephone technical support . . . . .	15
Installing the software . . . . .	1	<b>Appendix B. Lenovo Limited Warranty. . . . .</b>	<b>17</b>
Installing the mouse . . . . .	2	Part 1 - General Terms . . . . .	17
Using the software . . . . .	2	Part 2 - Country-specific Terms . . . . .	20
Troubleshooting . . . . .	3	Part 3 - Warranty Service Information . . . . .	22
Caring for the mouse . . . . .	4	Suplemento de Garantía para México. . . . .	24
<b>Chapter 2. ThinkPad Bluetooth Laser Mouse . . . . .</b>	<b>5</b>	<b>Appendix C. Electronic emission notices . . . . .</b>	<b>25</b>
Product description . . . . .	5	Federal Communications Commission Declaration of Conformity . . . . .	25
Installing the software . . . . .	6	<b>Appendix D. Notices. . . . .</b>	<b>43</b>
Installing the batteries . . . . .	6	Trademarks . . . . .	43
Using the mouse and the software . . . . .	6	Recycling information . . . . .	43
Bluetooth Easy Pair function . . . . .	7	Recycling information for Brazil . . . . .	44
Manually connecting your mouse . . . . .	7	<b>Appendix E. Restriction of Hazardous Substances Directive (RoHS) . . . . .</b>	<b>45</b>
Troubleshooting . . . . .	8	China RoHS. . . . .	45
<b>Chapter 3. Lenovo Laser Wireless Mouse . . . . .</b>	<b>9</b>	Turkish statement of compliance . . . . .	45
Product description . . . . .	9	Ukraine RoHS . . . . .	45
Installing the software . . . . .	9		
Installing the mouse . . . . .	10		
Storing the dongle . . . . .	12		
Troubleshooting . . . . .	12		



---

## About this user guide

This user guide provides instructions on installing and using the following mice:

- Lenovo® ScrollPoint® Mouse
- Lenovo USB Laser Mouse
- Lenovo USB Optical Wheel Mouse
- ThinkPad® USB Laser Mouse
- ThinkPad USB Travel Mouse
- ThinkPad Bluetooth Laser Mouse
- Lenovo Laser Wireless Mouse



---

## Chapter 1. Lenovo and ThinkPad mice

This chapter provides information about installing and using the following mice:

- Lenovo ScrollPoint Mouse
- Lenovo USB Laser Mouse
- Lenovo USB Optical Wheel Mouse
- ThinkPad USB Laser Mouse
- ThinkPad USB Travel Mouse

---

### Product description

The Lenovo ScrollPoint Mouse has a scrolling point, which enables you to control vertical and horizontal scrolling. Both the Lenovo USB Laser Mouse and the ThinkPad USB Laser Mouse enable you to control vertical and horizontal scrolling using the tilt wheel. For the other two mice, you can use the scrolling wheel to control vertical scrolling.

**Note:** You need to install the Lenovo Mouse Suite software before using the horizontal scrolling function.

Each mouse can be connected to any enabled Universal Serial Bus (USB) connector on your computer.

Each mouse is supported on the following operating systems:

- Microsoft® Windows® XP (32-bit)
- Microsoft Windows Vista® (32-bit or 64-bit)
- Microsoft Windows 7 (32-bit or 64-bit)

Each option package includes a mouse and the following:

- *Software and User Guide CD*
- *Laser Safety Manual*
- Warranty poster

**Note:** The *Laser Safety Manual* is only available in laser mouse packages.

---

### Installing the software

The *Software and User Guide CD* contains the Lenovo Mouse Suite software for the mouse. It is recommended that you install the Lenovo Mouse Suite software to customize advanced settings before you use the mouse.

**Note:** It is recommended that you uninstall any previously installed mouse software before installing the Lenovo Mouse Suite software.

To install the Lenovo Mouse Suite software, do the following:

1. Save any open documents and exit all applications.
2. Insert the *Software and User Guide CD* and do one of the following:
  - If the CD starts automatically, go to step 3.
  - If the AutoPlay window opens, click **Run start.bat**. Then, go to step 3.

- If the CD does not start automatically, go into **My Computer** or **Computer**, browse the CD/DVD drive, and double-click **Start.bat**.
3. Follow the instructions on the screen.

**Note:** In the Hardware Interface Selection window, select **USB (Universal Serial Bus) Interface**.

4. When prompted, restart your computer.

---

## Installing the mouse

This topic contains information about installing the mouse.

To install the mouse, connect the mouse to an available USB connector on your computer. The New Hardware Found window opens, and the Windows operating system will automatically install the proper device driver for the mouse. Then, the mouse is ready for use.

---

## Using the software

Each mouse has multiple functions and features such as zooming and auto-scrolling, which help you increase your productivity. You also can assign frequently used functions or shortcuts to the mouse buttons using the Lenovo Mouse Suite software.

To use the Lenovo Mouse Suite software, do the following:

1. Click **Start → All Programs → Lenovo Mouse Suite → Mouse Suite**.
2. The main window opens with several tabs. Click each tab to view related settings. On each tab there are four buttons:
  - **OK:** Save your settings and close the window.
  - **Cancel:** Exit the window without saving.
  - **Apply:** Have your changes take effect without closing the window.
  - **Help:** View the help information system.

**Note:** The Lenovo USB Laser Mouse supports the mouse resolution from 400 dots per inch (DPI) to 2000 DPI. By default, the mouse resolution setting is 1600 DPI. The ThinkPad USB Laser Mouse supports the mouse resolution from 400 DPI to 1600 DPI. By default, the mouse resolution setting is 1200 DPI. To change the resolution setting, do the following:

1. Click **Start → All Programs → Lenovo Mouse Suite → Mouse Suite**.
2. In the Mouse Properties window, click the **Lenovo** tab. Then, click **Advanced Properties**.
3. In the **Resolution Adjustment Setup** area, select the corresponding radio button to set the preferred mouse resolution.
4. To confirm your setting, click **Apply**. For more information about the setting, click **Help**.



---

## Troubleshooting

This topic contains troubleshooting information for the mice. If you encounter any of the following problems when using the mice, refer to the corresponding answers.

**Problem:** The mouse is not recognized by the operating system.

**Solution:** To solve the problem, perform one of the following procedures:

### Procedure A:

Check the following:

- Install the mouse again.
- Access your computer Basic Input/Output System (BIOS) Setup Utility program during the startup process and make sure that all the USB connectors on your computer are enabled.

#### Notes:

- For information about how to access or use the BIOS Setup Utility program on your computer, see the documentation that came with your computer.
- If all USB connectors on your computer do not work, probably the computer BIOS does not support them. To solve this problem, go to <http://www.lenovo.com/support> to download the latest BIOS updates, or go to <http://www.lenovo.com/support/phone> to find the Lenovo technical support for your country or region.

### Procedure B:

1. Click **Start** → **Control Panel**.
2. Depending on your Control Panel mode, double-click **System** or click **Performance and Maintenance** → **System**.
3. Click the **Hardware** tab.
4. Click **Device Manager**.
5. Scroll down until you find **Mice and other pointing devices**. Then, expand the **Mice and other pointing devices** category.
6. Right-click **HID-compliant mouse**, and then select **Uninstall**. A warning will be displayed, prompting you that you are going to remove a device from the operating system.
7. Click **OK**.
8. Right-click **Mice and other pointing devices**, and then select **Scan for hardware changes** to re-detect the hardware.

**Note:** You might be asked to insert the Windows installation CD.

**Problem:** The mouse pointer cannot move.

**Solution:** To solve the problem, do the following:

- Ensure that you have followed all installation procedures.
- Reinstall the Lenovo Mouse Suite software.
- Clean the mouse lens with a soft cotton swab. Do not use any other liquid or solvent to clean the mouse lens as this might cause damage to the lens.
- Put a mouse pad under the mouse. If the mouse is moving on a highly reflective surface, especially a glass or mirror surface, the mouse might not be able to work.

**Problem:** The horizontal scrolling speed cannot be changed on the **Wheel** tab in the Mouse Properties window.

**Solution:** To solve the problem, customize the horizontal scrolling speed setting by doing the following:

1. Click **Start → All Programs → Lenovo Mouse Suite → Mouse Suite**.
2. In the Mouse Properties window, click the **Lenovo** tab. Then, click **Advanced Properties**.
3. In the Advanced Properties window, click the **Wheel** tab.
4. In the **Horizontal Scrolling** area, move the slider right to increase or left to decrease the horizontal scrolling speed.

---

## Caring for the mouse

Always disconnect the mouse before cleaning. Keep beverages away from the mouse working area and avoid any spills. The maintenance of your mouse will ensure longer life and minimize the chances of causing damage to your mouse and computer. There are no user serviceable parts.

---

## Chapter 2. ThinkPad Bluetooth Laser Mouse

This chapter contains information about installing and using the ThinkPad Bluetooth Laser Mouse.

---

### Product description

The ThinkPad Bluetooth Laser Mouse has a tilt wheel to control vertical and horizontal scrolling. It uses the Bluetooth technology to connect to the operating system.

The following figure shows the front view and rear view of the ThinkPad Bluetooth Laser Mouse.

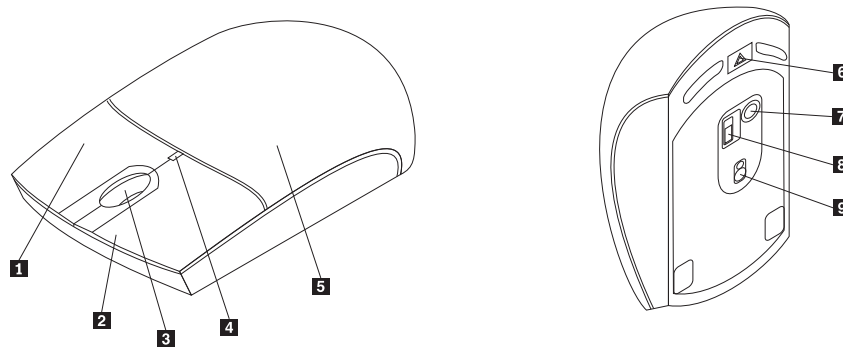

Figure 1. Front view and rear view of the mouse

- |                                    |   |
|------------------------------------|---|
| <b>1</b> Right button              | <b>6</b> Battery compartment release button |
| <b>2</b> Left button               | <b>7</b> Bluetooth connection button        |
| <b>3</b> Scrolling wheel           | <b>8</b> Power switch                       |
| <b>4</b> LED indicator             | <b>9</b> Laser output                       |
| <b>5</b> Battery compartment cover |   |

The mouse is supported on the following operating systems:

- Microsoft Windows XP (32-bit)
- Microsoft Windows Vista (32-bit or 64-bit)
- Microsoft Windows 7 (32-bit or 64-bit)

Your option package includes the following:

- ThinkPad Bluetooth Laser Mouse
- Two AA batteries
- *Software and User Guide CD*
- *Laser Safety Manual*
- Warranty poster

---

## Installing the software

The *Software and User Guide CD* contains the Lenovo Mouse Suite software for the mouse. It is recommended that you install the Lenovo Mouse Suite software to customize advanced settings before you use the mouse.

### Notes:

- It is recommended that you uninstall any previously installed mouse software before installing the Lenovo Mouse Suite software.
- Turn on the Bluetooth radio in your computer before installing the Lenovo Mouse Suite software.

To install the Lenovo Mouse Suite software, do the following:

1. Save any open documents and exit all applications.
2. Insert the *Software and User Guide CD* and do one of the following:
  - If the CD starts automatically, go to step 3.
  - If the AutoPlay window opens, click **Run start.bat**. Then, go to step 3.
  - If the CD does not start automatically, go into **My Computer** or **Computer**, browse the CD/DVD drive, and double-click **Start.bat**.
3. Follow the instructions on the screen.

**Note:** In the Hardware Interface Selection window, select **Bluetooth Interface**.

4. When prompted, restart your computer.

---

## Installing the batteries

The ThinkPad Bluetooth Laser Mouse needs two AA batteries to work with your computer. For better performance, it is recommended that you install alkaline batteries in your mouse.

To install the batteries, do the following:

1. Press the battery compartment release button to open the battery compartment cover.
2. Insert the two batteries according to the polarity indicators in the mouse.
3. Push down the battery compartment cover and slide it forward until it clicks into place.

### Notes:

- The green light-emitting diode (LED) indicates that the batteries are charged and the mouse is ready for use.
- The flashing amber LED indicates a low battery power level. You need to install new batteries.
- Push the power switch on the mouse to the off position when you are not using the mouse. This extends the battery life.

---

## Using the mouse and the software

The ThinkPad Bluetooth Laser Mouse has multiple functions and features such as zooming and auto-scrolling, which help you increase your productivity. You also can assign frequently used functions or shortcuts to the mouse buttons using the Lenovo Mouse Suite software. For more information about using the Lenovo Mouse Suite software, see “Using the software” on page .

---

## Bluetooth Easy Pair function

You can use the Bluetooth Easy Pair function if the Lenovo Mouse Suite software cannot detect the mouse or when you want to repair the connection between the mouse and the operating system.

**Note:** Before you use the Bluetooth Easy Pair function, do the following:

- Make sure that the batteries are correctly installed in the mouse.
- Make sure that the Bluetooth radio in your computer is turned on.

To use the Bluetooth Easy Pair function, do the following:

1. Click **Start** → **All Programs** → **Lenovo Mouse Suite** → **Bluetooth Easy Pair**.
2. Click **Next**.
3. Push the power switch on the mouse to the on position.
4. Hold the Bluetooth connection button for three seconds.
5. When the mouse is recognized by the operating system, a confirmation window opens. Click **Finish**.

**Note:** Some operating systems do not support the Bluetooth Easy Pair function. You can manually repair the connection. For information about manually connecting the mouse with the operating system, see “Manually connecting your mouse” on page 7.

---

## Manually connecting your mouse

To manually connect the mouse with the operating system or repair the connection between them, depending on your operating system, do one of the following:

**For the Windows XP operating system:**

1. Turn on the Bluetooth radio in your notebook computer.

**Note:** For ThinkPad notebook computers, press Fn+F5 to open the setting window of wireless radios, and then turn on the Bluetooth radio. The Bluetooth radio indicator turns green, and the Bluetooth device is ready for use. For more information about turning on the Bluetooth radio, refer to the user guide or the help information system of the Access Connections program that came with your computer.

2. Double-click the **My Bluetooth Places** icon in the Windows notification area or on the desktop.
3. Push the power switch on the mouse to the on position.
4. Hold the Bluetooth connection button for three seconds. The LED indicator starts to flash.
5. Depending on your menu mode, click **View devices in range** or **Search for devices in range**.
6. Double-click the **ThinkPad Bluetooth Laser Mouse** icon in the list.
7. A window opens to confirm that the mouse is connected with the operating system. Click **Close**.

**Note:** If a window opens indicating that the connection fails, right-click the **ThinkPad Bluetooth Laser Mouse** icon and select **Disable** to disable the mouse. Then, continue with step 5.

**For the Windows Vista or Windows 7 operating system:**

1. Turn on the Bluetooth radio in your notebook computer.

**Note:** For ThinkPad notebook computers, press Fn+F5 to open the setting window of wireless radios, and then turn on the Bluetooth radio. The Bluetooth radio indicator turns green, and the Bluetooth device is ready for use. For more information about turning on the Bluetooth radio, refer to the user guide or the help information system of the Access Connections program that came with your computer.

2. Click **Start → Control Panel**, and then depending on the operating system you are using, do one of the following:
  - For the Windows Vista operating system, double-click **Bluetooth Devices**, and then click **Add Wireless Device**.
  - For the Windows 7 operating system, click **Devices and Printers → Add a device**.
3. Push the power switch on the mouse to the on position.
4. Hold the Bluetooth connection button for three seconds. The LED indicator starts to flash.
5. Select the **ThinkPad Bluetooth Laser Mouse** icon from the list and click **Next**.

**Note:** If a window opens prompting that you need to select a connection way, select **Pair without using a code**.

6. The connection process automatically starts. When the connection process completes, click **Close**. Then, the mouse is ready for use.

**Note:** If a window opens indicating that the connection fails, click **Try Again**.

---

## Troubleshooting

This topic provides basic troubleshooting information when you encounter problems with your mouse.

**Problem:** The ThinkPad Bluetooth Laser Mouse is not recognized by your computer.

**Solution:** To solve the problem, do the following:

- Ensure that the Bluetooth radio is turned on and the Bluetooth works.
- Ensure that the Bluetooth connection button on the mouse is switched on.
- Log in to your notebook computer BIOS interface, and set all options related to mouse to default. For details about the BIOS settings, refer to the user guide that came with your notebook computer.
- Ensure that your notebook computer is compatible with the mouse.

**Problem:** The mouse pointer cannot move.

**Solution:** To solve the problem, do the following:

- Ensure that you have followed all installation procedures.
- Reinstall the Lenovo Mouse Suite software.
- Clean the mouse lens with a soft cotton swab. Do not use any other liquid or solvent to clean the mouse lens as this might cause damage to the lens.
- Put a mouse pad under the mouse. If the mouse is moving on a highly reflective surface, especially a glass or mirror surface, the mouse might not be able to work.

**Problem:** The horizontal scrolling speed cannot be changed on the **Wheel** tab in the Mouse Properties window.

**Solution:** To solve the problem, customize the horizontal scrolling speed setting by doing the following:

1. Click **Start → All Programs → Lenovo Mouse Suite → Mouse Suite**.
2. In the Mouse Properties window, click the **Lenovo** tab. Then, click **Advanced Properties**.
3. In the Advanced Properties window, click the **Wheel** tab.
4. In the **Horizontal Scrolling** area, move the slider right to increase or left to decrease the horizontal scrolling speed.

---

## Chapter 3. Lenovo Laser Wireless Mouse

This chapter contains information about installing and using the Lenovo Laser Wireless Mouse.

---

### Product description

The Lenovo Laser Wireless Mouse features high-precision laser and scrolling wheel, which help you easily navigate through documents and Web pages. The micro-size dongle, which supports the plug and play functionality, is stored neatly inside the mouse for travel.

The following figure shows the front view and rear view of the Lenovo Laser Wireless Mouse.

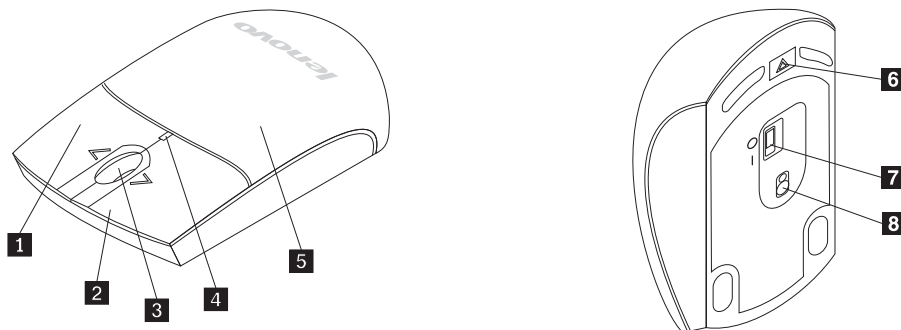

Figure 2. Mouse front view and rear view

- |                                    |   |
|------------------------------------|---|
| <b>1</b> Right button              | <b>6</b> Battery compartment release button |
| <b>2</b> Left button               | <b>7</b> Power switch                       |
| <b>3</b> Scrolling wheel           | <b>8</b> Laser output                       |
| <b>4</b> LED indicator             |   |
| <b>5</b> Battery compartment cover |   |

The mouse is supported on the following operating systems:

- Microsoft Windows XP (32-bit)
- Microsoft Windows Vista (32-bit or 64-bit)
- Microsoft Windows 7 (32-bit or 64-bit)

Your option package includes the following:

- Lenovo Laser Wireless Mouse (including the dongle)
- Setup and warranty poster

---

### Installing the software

It is recommended that you install the Lenovo Mouse Suite software to customize advanced settings before you use the mouse.

To install the Lenovo Mouse Suite software, do the following:

1. Go to <http://www.lenovo.com/support/mice>.
2. Click the name of the mouse.
3. Scroll down until you find **Software and device drivers**. Then, click **Software and device drivers**.
4. Locate and download the installation file of the Lenovo Mouse Suite software.
5. Double-click the installation file, and follow the instructions on the screen to complete the installation.

---

## Installing the mouse

This topic provides information on how to install the mouse.

To install the mouse, do the following:

1. Press the battery compartment release button to open the battery compartment cover.

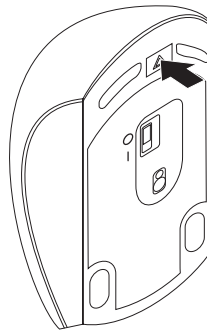

*Figure 3. Opening the battery compartment cover*



4. Insert two AA batteries into the mouse compartment according to the polarity indicators.

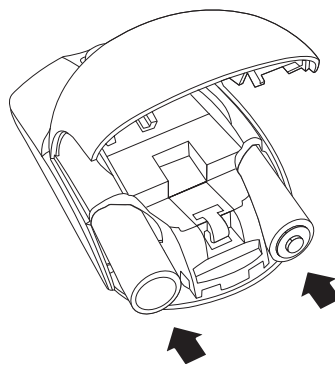

Figure 6. Installing the mouse batteries

**CAUTION:**

**There is a risk of explosion if a battery is replaced by an incorrect type. Dispose of used batteries according to the instructions.**

5. Close the battery compartment cover and slide it forward until it clicks into place.

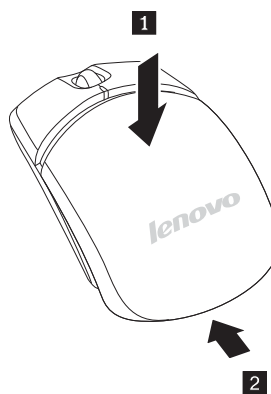
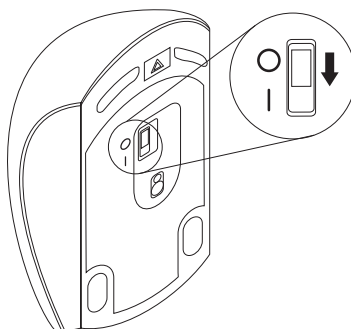

Figure 7. Closing the battery compartment cover

6. Push the power switch on the mouse to the on position and the LED indicator is on.



*Figure 8. Turning on the power switch*

**Notes:**

- The green LED indicates that the mouse is ready for use.
- The flashing red LED indicates a low battery power level.
- Push the power switch on the mouse to the off position when you are not using the mouse. This extends the battery life.

---

## Troubleshooting

This topic provides basic troubleshooting information when you encounter problems with your mouse.

**Problem:** The mouse pointer cannot move.

**Solution:** To solve the problem, do the following:

- Ensure that you have followed all installation procedures.
- Reinstall the Lenovo Mouse Suite software.
- Clean the mouse lens with a soft cotton swab. Do not use any other liquid or solvent to clean the mouse lens as this might cause damage to the lens.

- Put a mouse pad under the mouse. If the mouse is moving on a highly reflective surface, especially a glass or mirror surface, the mouse might not be able to work.

**Problem:** The horizontal scrolling speed cannot be changed on the **Wheel** tab in the Mouse Properties window.

**Solution:** To solve the problem, customize the horizontal scrolling speed setting by doing the following:

1. Click **Start → All Programs → Lenovo Mouse Suite → Mouse Suite**.
2. In the Mouse Properties window, click the **Lenovo** tab. Then, click **Advanced Properties**.
3. In the Advanced Properties window, click the **Wheel** tab.
4. In the **Horizontal Scrolling** area, move the slider right to increase or left to decrease the horizontal scrolling speed.



---

## Appendix A. Service and Support

The following information describes the technical support that is available for your product, during the warranty period or throughout the life of your product. Refer to the Lenovo Limited Warranty for a full explanation of Lenovo warranty terms.

---

### Online technical support

Online technical support is available during the lifetime of a product at:  
<http://www.lenovo.com/support>

Product replacement assistance or exchange of defective components also is available during the warranty period. In addition, if your option is installed in a Lenovo computer, you might be entitled to service at your location. A Lenovo technical support representative can help you determine the best alternative.

---

### Telephone technical support

Installation and configuration support through the Customer Support Center will be available until 90 days after the option has been withdrawn from marketing. After that time, the support is cancelled, or made available for a fee, at Lenovo's discretion. Additional support is also available for a nominal fee.

Before contacting a Lenovo technical support representative, please have the following information available: option name and number, proof of purchase, computer manufacturer, model, serial number and manual, the exact wording of any error message, description of the problem, and the hardware and software configuration information for your system.

Your technical support representative might want to walk you through the problem while you are at your computer during the call.

Telephone numbers are subject to change without notice. The most up-to-date telephone list for Lenovo Support is always available at <http://www.lenovo.com/support/phone>. If the telephone number for your country or region is not listed, contact your Lenovo reseller or Lenovo marketing representative.



---

## Appendix B. Lenovo Limited Warranty

L505-0010-02 08/2011

This Lenovo Limited Warranty consists of the following parts:

**Part 1 - General Terms**

**Part 2 - Country-specific Terms**

**Part 3 - Warranty Service Information**

The terms of **Part 2** replace or modify terms of **Part 1** as specified for a particular country.

---

### Part 1 - General Terms

This Lenovo Limited Warranty applies only to Lenovo hardware products you purchased for your own use and not for resale. This Lenovo Limited Warranty is available in other languages at [www.lenovo.com/warranty](http://www.lenovo.com/warranty).

#### What this Warranty Covers

Lenovo warrants that each Lenovo hardware product that you purchase is free from defects in materials and workmanship under normal use during the warranty period. The warranty period for the product starts on the original date of purchase as shown on your sales receipt or invoice or as may be otherwise specified by Lenovo. The warranty period and type of warranty service that apply to your product are as specified in "**Part 3 - Warranty Service Information**" below. This warranty only applies to products in the country or region of purchase.

**THIS WARRANTY IS YOUR EXCLUSIVE WARRANTY AND REPLACES ALL OTHER WARRANTIES OR CONDITIONS, EXPRESS OR IMPLIED, INCLUDING, BUT NOT LIMITED TO, ANY IMPLIED WARRANTIES OR CONDITIONS OF MERCHANTABILITY OR FITNESS FOR A PARTICULAR PURPOSE. AS SOME STATES OR JURISDICTIONS DO NOT ALLOW THE EXCLUSION OF EXPRESS OR IMPLIED WARRANTIES, THE ABOVE EXCLUSION MAY NOT APPLY TO YOU. IN THAT EVENT, SUCH WARRANTIES APPLY ONLY TO THE EXTENT AND FOR SUCH DURATION AS REQUIRED BY LAW AND ARE LIMITED IN DURATION TO THE WARRANTY PERIOD. AS SOME STATES OR JURISDICTIONS DO NOT ALLOW LIMITATIONS ON THE DURATION OF AN IMPLIED WARRANTY, THE ABOVE LIMITATION ON DURATION MAY NOT APPLY TO YOU.**

#### How to Obtain Warranty Service

If the product does not function as warranted during the warranty period, you may obtain warranty service by contacting Lenovo or a Lenovo approved Service Provider. A list of approved Service Providers and their telephone numbers is available at: [www.lenovo.com/support/phone](http://www.lenovo.com/support/phone).

Warranty service may not be available in all locations and may differ from location to location. Charges may apply outside a Service Provider's normal service area. Contact a local Service Provider for information specific to your location.

#### Customer Responsibilities for Warranty Service

Before warranty service is provided, you must take the following steps:

- follow the service request procedures specified by the Service Provider;

- backup or secure all programs and data contained in the product;
- provide the Service Provider with all system keys or passwords;
- provide the Service Provider with sufficient, free, and safe access to your facilities to perform service;
- remove all data, including confidential information, proprietary information and personal information, from the product or, if you are unable to remove any such information, modify the information to prevent its access by another party or so that it is not personal data under applicable law. The Service Provider shall not be responsible for the loss or disclosure of any data, including confidential information, proprietary information, or personal information, on a product returned or accessed for warranty service;
- remove all features, parts, options, alterations, and attachments not covered by the warranty;
- ensure that the product or part is free of any legal restrictions that prevent its replacement;
- if you are not the owner of a product or part, obtain authorization from the owner for the Service Provider to provide warranty service.

### **What Your Service Provider Will Do to Correct Problems**

When you contact a Service Provider, you must follow the specified problem determination and resolution procedures.

The Service Provider will attempt to diagnose and resolve your problem by telephone, e-mail or remote assistance. The Service Provider may direct you to download and install designated software updates.

Some problems may be resolved with a replacement part that you install yourself called a “Customer Replaceable Unit” or “CRU.” If so, the Service Provider will ship the CRU to you for you to install.

If your problem cannot be resolved over the telephone; through the application of software updates or the installation of a CRU, the Service Provider will arrange for service under the type of warranty service designated for the product under “**Part 3 - Warranty Service Information**” below.

If the Service Provider determines that it is unable to repair your product, the Service Provider will replace it with one that is at least functionally equivalent.

If the Service Provider determines that it is unable to either repair or replace your product, your sole remedy under this Limited Warranty is to return the product to your place of purchase or to Lenovo for a refund of your purchase price.

### **Replacement Products and Parts**

When warranty service involves the replacement of a product or part, the replaced product or part becomes Lenovo’s property and the replacement product or part becomes your property. Only unaltered Lenovo products and parts are eligible for replacement. The replacement product or part provided by Lenovo may not be new, but it will be in good working order and at least functionally equivalent to the original product or part. The replacement product or part shall be warranted for the balance of the period remaining on the original product.

### **Use of Personal Contact Information**

If you obtain service under this warranty, you authorize Lenovo to store, use and process information about your warranty service and your contact information, including name, phone numbers, address, and e-mail address. Lenovo may use this information to perform service under this warranty. We may contact you to inquire about your satisfaction with our warranty service or to notify you about any product recalls or safety issues. In accomplishing these purposes, you authorize Lenovo to transfer your information to any country where we do business and to provide it to entities acting on our behalf. We may also disclose it where required by law. Lenovo’s privacy policy is available at [www.lenovo.com/](http://www.lenovo.com/).



### **What this Warranty Does not Cover**

This warranty does not cover the following:

- uninterrupted or error-free operation of a product;
- loss of, or damage to, your data by a product;
- any software programs, whether provided with the product or installed subsequently;
- failure or damage resulting from misuse, abuse, accident, modification, unsuitable physical or operating environment, natural disasters, power surges, improper maintenance, or use not in accordance with product information materials;
- damage caused by a non-authorized service provider;
- failure of, or damage caused by, any third party products, including those that Lenovo may provide or integrate into the Lenovo product at your request;
- any technical or other support, such as assistance with “how-to” questions and those regarding product set-up and installation;
- products or parts with an altered identification label or from which the identification label has been removed.

### **Limitation of Liability**

Lenovo is responsible for loss or damage to your product only while it is in the Service Provider’s possession or in transit, if the Service Provider is responsible for the transportation.

Neither Lenovo nor the Service Provider is responsible for loss or disclosure of any data, including confidential information, proprietary information, or personal information, contained in a product.

**UNDER NO CIRCUMSTANCES, AND NOTWITHSTANDING THE FAILURE OF ESSENTIAL PURPOSE OF ANY REMEDY SET FORTH HEREIN, SHALL LENOVO, ITS AFFILIATES, SUPPLIERS, RESELLERS, OR SERVICE PROVIDERS BE LIABLE FOR ANY OF THE FOLLOWING EVEN IF INFORMED OF THEIR POSSIBILITY AND REGARDLESS OF WHETHER THE CLAIM IS BASED IN CONTRACT, WARRANTY, NEGLIGENCE, STRICT LIABILITY OR OTHER THEORY OF LIABILITY: 1) THIRD PARTY CLAIMS AGAINST YOU FOR DAMAGES; 2) LOSS, DAMAGE OR DISCLOSURE OF YOUR DATA; 3) SPECIAL, INCIDENTAL, PUNITIVE, INDIRECT OR CONSEQUENTIAL DAMAGES, INCLUDING BUT NOT LIMITED TO LOST PROFITS, BUSINESS REVENUE, GOODWILL OR ANTICIPATED SAVINGS. IN NO CASE SHALL THE TOTAL LIABILITY OF LENOVO, ITS AFFILIATES, SUPPLIERS, RESELLERS OR SERVICE PROVIDERS FOR DAMAGES FROM ANY CAUSE EXCEED THE AMOUNT OF ACTUAL DIRECT DAMAGES, NOT TO EXCEED THE AMOUNT PAID FOR THE PRODUCT.**

**THE FOREGOING LIMITATIONS DO NOT APPLY TO DAMAGES FOR BODILY INJURY (INCLUDING DEATH), DAMAGE TO REAL PROPERTY OR DAMAGE TO TANGIBLE PERSONAL PROPERTY FOR WHICH LENOVO IS LIABLE UNDER LAW. AS SOME STATES OR JURISDICTIONS DO NOT ALLOW THE EXCLUSION OR LIMITATION OF INCIDENTAL OR CONSEQUENTIAL DAMAGES, THE ABOVE LIMITATION OR EXCLUSION MAY NOT APPLY TO YOU.**

### **Your Other Rights**

**THIS WARRANTY GIVES YOU SPECIFIC LEGAL RIGHTS. YOU MAY HAVE OTHER RIGHTS ACCORDING TO THE APPLICABLE LAWS OF YOUR STATE OR JURISDICTION. YOU MAY ALSO HAVE OTHER RIGHTS UNDER A WRITTEN AGREEMENT WITH LENOVO. NOTHING IN THIS WARRANTY AFFECTS STATUTORY RIGHTS, INCLUDING RIGHTS OF CONSUMERS UNDER LAWS OR REGULATIONS GOVERNING THE SALE OF CONSUMER GOODS THAT CANNOT BE WAIVED OR LIMITED BY CONTRACT.**

---

## Part 2 - Country-specific Terms

### Australia

“Lenovo” means Lenovo (Australia & New Zealand) Pty Limited ABN 70 112 394 411. Address: Level 10, North Tower, 1-5 Railway Street, Chatswood, NSW, 2067. Telephone: +61 2 8003 8200. Email: lensyd\_au@lenovo.com

*The following replaces the same section in Part 1:*

#### **What this Warranty Covers:**

Lenovo warrants that each hardware product that you purchase is free from defects in materials and workmanship under normal use and conditions during the warranty period. If the product fails due to a covered defect during the warranty period, Lenovo will provide you a remedy under this Limited Warranty. The warranty period for the product starts on the original date of purchase specified on your sales receipt or invoice unless Lenovo informs you otherwise in writing. The warranty period and type of warranty service that apply to your product are set forth below in **Part 3 - Warranty Service Information**.

**THE BENEFITS GIVEN BY THIS WARRANTY ARE IN ADDITION TO YOUR RIGHTS AND REMEDIES AT LAW, INCLUDING THOSE UNDER THE AUSTRALIAN CONSUMER LAW.**

*The following replaces the same section in Part 1:*

#### **Replacement Products and Parts:**

When warranty service involves the replacement of a product or part, the replaced product or part becomes Lenovo’s property and the replacement product or part becomes your property. Only unaltered Lenovo products and parts are eligible for replacement. The replacement product or part provided by Lenovo may not be new, but it will be in good working order and at least functionally equivalent to the original product or part. The replacement product or part shall be warranted for the balance of the period remaining on the original product. Products and parts presented for repair may be replaced by refurbished products or parts of the same type rather than being repaired. Refurbished parts may be used to repair the product; and repair of the product may result in loss of data, if the product is capable of retaining user-generated data.

*The following is added to the same section in Part 1:*

#### **Use of Personal Contact Information:**

Lenovo will not be able to perform our service under this warranty if you refuse to provide your information or do not wish us to transfer your information to our agent or contractor. You have the right to access your personal contact information and request correction of any errors in it pursuant to the Privacy Act 1988 by contacting Lenovo.

*The following replaces the same section in Part 1:*

#### **Limitation of Liability:**

Lenovo is responsible for loss or damage to your product only while it is in the Service Provider’s possession or in transit, if the Service Provider is responsible for the transportation.

Neither Lenovo nor the Service Provider is responsible for loss or disclosure of any data, including confidential information, proprietary information, or personal information, contained in a product.

**TO THE EXTENT PERMITTED BY LAW, UNDER NO CIRCUMSTANCES AND NOTWITHSTANDING THE FAILURE OF ESSENTIAL PURPOSE OF ANY REMEDY SET FORTH HEREIN, SHALL LENOVO, ITS AFFILIATES, SUPPLIERS, RESELLERS, OR SERVICE PROVIDERS BE LIABLE FOR ANY OF THE FOLLOWING EVEN IF INFORMED OF THEIR POSSIBILITY AND REGARDLESS OF WHETHER THE CLAIM IS BASED IN CONTRACT, WARRANTY, NEGLIGENCE, STRICT LIABILITY OR OTHER THEORY OF LIABILITY: 1) THIRD PARTY CLAIMS AGAINST YOU FOR DAMAGES; 2) LOSS, DAMAGE OR DISCLOSURE OF YOUR DATA; 3) SPECIAL, INCIDENTAL, PUNITIVE, INDIRECT OR CONSEQUENTIAL DAMAGES, INCLUDING BUT NOT LIMITED TO LOST PROFITS, BUSINESS REVENUE, GOODWILL OR ANTICIPATED SAVINGS. IN NO CASE SHALL THE TOTAL LIABILITY OF LENOVO, ITS AFFILIATES, SUPPLIERS, RESELLERS OR SERVICE PROVIDERS FOR DAMAGES FROM ANY CAUSE EXCEED THE AMOUNT OF ACTUAL DIRECT DAMAGES, NOT TO EXCEED THE AMOUNT PAID FOR THE PRODUCT.**

**THE FOREGOING LIMITATIONS DO NOT APPLY TO DAMAGES FOR BODILY INJURY (INCLUDING DEATH), DAMAGE TO REAL PROPERTY OR DAMAGE TO TANGIBLE PERSONAL PROPERTY FOR WHICH LENOVO IS LIABLE UNDER LAW.**

*The following replaces the same section in Part 1:*

**Your Other Rights:**

**THIS WARRANTY GIVES YOU SPECIFIC LEGAL RIGHTS. YOU ALSO HAVE OTHER RIGHTS AT LAW, INCLUDING UNDER THE AUSTRALIAN CONSUMER LAW. NOTHING IN THIS WARRANTY AFFECTS STATUTORY RIGHTS OR RIGHTS AT LAW, INCLUDING RIGHTS THAT CANNOT BE WAIVED OR LIMITED BY CONTRACT.**

For example, our products come with guarantees that cannot be excluded under the Australian Consumer Law. You are entitled to a replacement or refund for a major failure and compensation for any other reasonably foreseeable loss or damage. You are also entitled to have the products repaired or replaced if the products fail to be of acceptable quality and the failure does not amount to a major failure.

**New Zealand**

*The following is added to the same section in Part 1:*

**Use of Personal Information:**

Lenovo will not be able to perform our service under this warranty if you refuse to provide your information or do not wish us to transfer your information to our agent or contractor. You have the right to access your personal information and request correction of any errors in it pursuant to the Privacy Act 1993 by contacting Lenovo (Australia & New Zealand) Pty Limited ABN 70 112 394 411. Address: Level 10, North Tower, 1-5 Railway Street, Chatswood, NSW, 2067. Telephone: 61 2 8003 8200. Email: lensyd\_au@lenovo.com

**Bangladesh, Cambodia, India, Indonesia, Nepal, Philippines, Vietnam and Sri Lanka**

*The following is added to Part 1:*

**Dispute Resolution**

Disputes arising out of or in connection with this warranty shall be finally settled by arbitration held in Singapore. This warranty shall be governed, construed and enforced in accordance with the laws of Singapore, without regard to conflict of laws. If you acquired the product in **India**, disputes arising out of or in connection with this warranty shall be finally settled by arbitration held in Bangalore, India. Arbitration in Singapore shall be held in accordance with the Arbitration Rules of Singapore International Arbitration Center ("SIAC Rules") then in effect. Arbitration in India shall be held in accordance with the laws of India then in effect. The arbitration award shall be final and binding on the parties without appeal. Any award

shall be in writing and set forth the findings of fact and the conclusions of law. All arbitration proceedings, including all documents presented in such proceedings shall be conducted in the English language. The English language version of this warranty prevails over any other language version in such proceedings.

### **European Economic Area (EEA)**

*The following is added to Part 1:*

Customers in the EEA may contact Lenovo at the following address: EMEA Service Organisation, Lenovo (International) B.V., Floor 2, Einsteinova 21, 851 01, Bratislava, Slovakia. Service under this warranty for Lenovo hardware products purchased in EEA countries may be obtained in any EEA country in which the product has been announced and made available by Lenovo.

### **Russia**

*The following is added to Part 1:*

### **Product Service Life**

The product service life is four (4) years from the original date of purchase.

## **Part 3 - Warranty Service Information**

<b>Product Type</b>	<b>Country or Region of Purchase</b>	<b>Warranty Period</b>	<b>Type of Warranty Service</b>
Lenovo ScrollPoint Mouse	Worldwide	1 year	1, 4
Lenovo USB Laser Mouse	Worldwide	1 year	1, 4
Lenovo USB Optical Wheel Mouse	Worldwide	1 year	1, 4
ThinkPad USB Laser Mouse	Worldwide	1 year	1, 4
ThinkPad USB Travel Mouse	Worldwide	1 year	1, 4
ThinkPad Bluetooth Laser Mouse	Worldwide	1 year	1, 4
Lenovo Laser Wireless Mouse	Worldwide	1 year	1, 4

If required, your Service Provider will provide repair or exchange service depending on the type of warranty service specified for your product and the available service. Scheduling of service will depend upon the time of your call, parts availability, and other factors.

### **Types of Warranty Service**

#### **1. Customer Replaceable Unit (“CRU”) Service**

Under CRU Service, the Service Provider will ship CRUs to you at its cost for installation by you. CRU information and replacement instructions are shipped with your product and are available from Lenovo at any time upon request. CRUs that are easily installed by you are called “Self-service CRUs”. “Optional-service CRUs” are CRUs that may require some technical skill and tools. Installation of Self-service CRUs is your responsibility. You may request that a Service Provider install Optional-service CRUs under one of the other

types of warranty service designated for your product. An optional service offering may be available for purchase from a Service Provider or Lenovo under which Self-service CRUs would be installed for you. You may find a list of CRUs and their designation in the publication that was shipped with your product or at [www.lenovo.com/CRUs](http://www.lenovo.com/CRUs). The requirement to return a defective CRU, if any, will be specified in the instructions shipped with a replacement CRU. When return is required: 1) return instructions, a prepaid return shipping label, and a container will be included with the replacement CRU; and 2) you may be charged for the replacement CRU if the Service Provider does not receive the defective CRU from you within thirty (30) days of your receipt of the replacement CRU.

## **2. On-site Service**

Under On-Site Service, a Service Provider will either repair or exchange the product at your location. You must provide a suitable working area to allow disassembly and reassembly of the product. Some repairs may need to be completed at a service center. If so, the Service Provider will send the product to the service center at its expense.

## **3. Courier or Depot Service**

Under Courier or Depot Service, your product will be repaired or exchanged at a designated service center, with shipping at the expense of the Service Provider. You are responsible for disconnecting the product and packing it in a shipping container provided to you to return your product to a designated service center. A courier will pick up your product and deliver it to the designated service center. The service center will return the product to you at its expense.

## **4. Customer Carry-In Service**

Under Customer Carry-In Service, your product will be repaired or exchanged after you deliver it to a designated service center at your risk and expense. After the product has been repaired or exchanged, it will be made available to you for collection. If you fail to collect the product, the Service Provider may dispose of the product as it sees fit, with no liability to you.

## **5. Mail-In Service**

Under Mail-In Service, your product will be repaired or exchanged at a designated service center after you deliver it at your risk and expense. After the product has been repaired or exchanged, it will be returned to you at Lenovo's risk and expense, unless the Service Provider specifies otherwise.

## **6. Customer Two-Way Mail-In Service**

Under Customer Two-Way Mail-In Service, your product will be repaired or exchanged after you deliver it to a designated service center at your risk and expense. After the product has been repaired or exchanged, it will be made available to you for return shipping at your risk and expense. If you fail to arrange return shipment, the Service Provider may dispose of the product as it sees fit, with no liability to you.

## **7. Product Exchange Service**

Under Product Exchange Service, Lenovo will ship a replacement product to your location. You are responsible for its installation and verification of its operation. The replacement product becomes your property in exchange for the failed product, which becomes the property of Lenovo. You must pack the failed product in the shipping carton in which you received the replacement product and return it to Lenovo. Transportation charges, both ways, shall be at Lenovo's expense. If you fail to use the carton in which the replacement product was received, you may be responsible for any damage to the failed product occurring during shipment. You may be charged for the replacement product if Lenovo does not receive the failed product within thirty (30) days of your receipt of the replacement product.

---

## Suplemento de Garantía para México

Este Suplemento se considera parte integrante de la Garantía Limitada de Lenovo y será efectivo única y exclusivamente para los productos distribuidos y comercializados dentro del Territorio de los Estados Unidos Mexicanos. En caso de conflicto, se aplicarán los términos de este Suplemento.

Todos los programas de software precargados en el equipo sólo tendrán una garantía de treinta (30) días por defectos de instalación desde la fecha de compra. Lenovo no es responsable de la información incluida en dichos programas de software y/o cualquier programa de software adicional instalado por Usted o instalado después de la compra del producto.

Los servicios no cubiertos por la garantía se cargarán al usuario final, previa obtención de una autorización.

En el caso de que se precise una reparación cubierta por la garantía, por favor, llame al Centro de soporte al cliente al 001-866-434-2080, donde le dirigirán al Centro de servicio autorizado más cercano. Si no existiese ningún Centro de servicio autorizado en su ciudad, población o en un radio de 70 kilómetros de su ciudad o población, la garantía incluirá cualquier gasto de entrega razonable relacionado con el transporte del producto a su Centro de servicio autorizado más cercano. Por favor, llame al Centro de servicio autorizado más cercano para obtener las aprobaciones necesarias o la información relacionada con el envío del producto y la dirección de envío.

Para obtener una lista de los Centros de servicio autorizados, por favor, visite:  
<http://www.lenovo.com/mx/es/servicios>

**Importado por:**

**Lenovo México S. de R.L. de C.V.**

**Av. Santa Fe 505, Piso 15**

**Col. Cruz Manca**

**Cuajimalpa, D.F., México**

**C.P. 05349**

**Tel. (55) 5000 8500**

---

## Appendix C. Electronic emission notices

The following information refers to:

- Lenovo ScrollPoint Mouse
- Lenovo USB Laser Mouse
- Lenovo USB Optical Wheel Mouse
- ThinkPad USB Laser Mouse
- ThinkPad USB Travel Mouse
- ThinkPad Bluetooth Laser Mouse
- Lenovo Laser Wireless Mouse

---

### Federal Communications Commission Declaration of Conformity

- **Lenovo ScrollPoint Mouse** - 31P7405
- **Lenovo USB Laser Mouse** - 41U3074
- **Lenovo USB Optical Wheel Mouse** - 06P4069
- **ThinkPad USB Laser Mouse** - 57Y4635
- **ThinkPad USB Travel Mouse** - 31P7410
- **ThinkPad Bluetooth Laser Mouse** - 41U5008
- **Lenovo Laser Wireless Mouse** - 0A36188, 0A36189

**ThinkPad Bluetooth Laser Mouse** (FCC ID: EMJMMOBT9LA)

This equipment has been tested and found to comply with the limits for a Class B digital device, pursuant to Part 15 of the FCC Rules. These limits are designed to provide reasonable protection against harmful interference in a residential installation. This equipment generates, uses, and can radiate radio frequency energy and, if not installed and used in accordance with the instructions, may cause harmful interference to radio communications. However, there is no guarantee that interference will not occur in a particular installation. If this equipment does cause harmful interference to radio or television reception, which can be determined by turning the equipment off and on, the user is encouraged to try to correct the interference by one or more of the following measures:

- Reorient or relocate the receiving antenna.
- Increase the separation between the equipment and receiver.
- Connect the equipment into an outlet on a circuit different from that to which the receiver is connected.
- Consult an authorized dealer or service representative for help.

Lenovo is not responsible for any radio or television interference caused by using other than specified or recommended cables and connectors or by unauthorized changes or modifications to this equipment. Unauthorized changes or modifications could void the user's authority to operate the equipment.

This device complies with Part 15 of the FCC Rules. Operation is subject to the following two conditions: (1) this device may not cause harmful interference, and (2) this device must accept any interference received, including interference that may cause undesired operation.

Responsible Party:  
Lenovo (United States) Incorporated  
1009 Think Place - Building One  
Morrisville, NC 27560  
Phone Number: 919-294-5900



### **RF Exposure Statement**

The radiated energy from the Lenovo Laser Wireless Mouse conforms to the FCC limit of the SAR (Specific Absorption Rate) requirement set forth in 47 CFR Part 2 section 1093.

### **Canada - Industry Canada (IC)**

**ThinkPad Bluetooth Laser Mouse** (IC ID: 4251A-MMOBTC9LA)

### **Industry Canada Class B emission compliance statement**

This Class B digital apparatus complies with Canadian ICES-003.

### **Avis de conformité à la réglementation d'Industrie Canada**

Cet appareil numérique de la classe B est conforme à la norme NMB-003 du Canada.

### **Low Power License-Exempt Radio Communication Devices (RSS-210)**

Operation is subject to the following two conditions: (1) this device may not cause interference, and (2) this device must accept any interference, including interference that may cause undesired operation of the device.

### **Permis d'émission à faible puissance - Cas des appareils de communications radio**

L'utilisation de ce dispositif est autorisée seulement aux conditions suivantes: (1) il ne doit pas produire de brouillage, et (2) l'utilisateur du dispositif doit être prêt à accepter tout brouillage radioélectrique reçu, même si ce brouillage est susceptible de compromettre le fonctionnement du dispositif.

### **Exposure of humans to RF fields (RSS-102)**

The Lenovo Laser Wireless Mouse and Dongle employ low gain integral antennas that do not emit RF field in excess of Health Canada limits for the general population; consult Safety Code 6, obtainable from Health Canada's Web site at <http://www.hc-sc.gc.ca/>

The radiated energy from the Lenovo Laser Wireless Mouse and Dongle antennas conforms to the IC limit of the RF exposure requirement regarding IC RSS-102, Issue 2 clause 4.2.



## **Exposition des êtres humains aux champs radioélectriques (RF) (CNR-102)**

La souris et le dongle utilisent des antennes intégrales à faible gain qui n'émettent pas un champ électromagnétique supérieur aux normes imposées par le Ministère de la santé canadien pour la population ; consultez le Safety Code 6 sur le site Web du Ministère de la santé canadien à l'adresse <http://www.hc-sc.gc.ca/>

L'énergie émise par les antennes du la souris et le dongle respecte la limite d'exposition aux radiofréquences telle que définie par Industrie Canada dans la clause 4.2 du document CNR-102.

## **EU-EMC Directive (2004/108/EC) EN 55022 class B Statement of Compliance**

### **Deutschsprachiger EU Hinweis:**

#### **Hinweis für Geräte der Klasse B EU-Richtlinie zur Elektromagnetischen Verträglichkeit**

Dieses Produkt entspricht den Schutzanforderungen der EU-Richtlinie 2004/108/EG (früher 89/336/EWG) zur Angleichung der Rechtsvorschriften über die elektromagnetische Verträglichkeit in den EU-Mitgliedsstaaten und hält die Grenzwerte der EN 55022 Klasse B ein.

Um dieses sicherzustellen, sind die Geräte wie in den Handbüchern beschrieben zu installieren und zu betreiben. Des Weiteren dürfen auch nur von der Lenovo empfohlene Kabel angeschlossen werden. Lenovo übernimmt keine Verantwortung für die Einhaltung der Schutzanforderungen, wenn das Produkt ohne Zustimmung der Lenovo verändert bzw. wenn Erweiterungskomponenten von Fremdherstellern ohne Empfehlung der Lenovo gesteckt/eingebaut werden.

### **Deutschland:**

#### **Einhaltung des Gesetzes über die elektromagnetische Verträglichkeit von Betriebsmitteln**

Dieses Produkt entspricht dem „Gesetz über die elektromagnetische Verträglichkeit von Betriebsmitteln“ EMVG (früher „Gesetz über die elektromagnetische Verträglichkeit von Geräten“). Dies ist die Umsetzung der EU-Richtlinie 2004/108/EG (früher 89/336/EWG) in der Bundesrepublik Deutschland.

#### **Zulassungsbescheinigung laut dem Deutschen Gesetz über die elektromagnetische Verträglichkeit von Betriebsmitteln, EMVG vom 20. Juli 2007 (früher Gesetz über die elektromagnetische Verträglichkeit von Geräten), bzw. der EMV EG Richtlinie 2004/108/EC (früher 89/336/EWG), für Geräte der Klasse B.**

Dieses Gerät ist berechtigt, in Übereinstimmung mit dem Deutschen EMVG das EG-Konformitätszeichen - CE - zu führen. Verantwortlich für die Konformitätserklärung nach Paragraf 5 des EMVG ist die Lenovo (Deutschland) GmbH, Gropiusplatz 10, D-70563 Stuttgart.

Informationen in Hinsicht EMVG Paragraf 4 Abs. (1) 4:

**Das Gerät erfüllt die Schutzanforderungen nach EN 55024 und EN 55022 Klasse B.**

### **European Union - Compliance to the Electromagnetic Compatibility Directive**

This product is in conformity with the protection requirements of EU Council Directive 2004/108/EC on the approximation of the laws of the Member States relating to electromagnetic compatibility. Lenovo cannot accept responsibility for any failure to satisfy the protection requirements resulting from a non-recommended modification of the product, including the installation of option cards from other manufacturers.

This product has been tested and found to comply with the limits for Class B Information Technology Equipment according to European Standard EN 55022. The limits for Class B equipment were derived for typical residential environments to provide reasonable protection against interference with licensed communication devices.

## Avis de conformité à la directive de l'Union Européenne

Le présent produit satisfait aux exigences de protection énoncées dans la directive 2004/108/EC du Conseil concernant le rapprochement des législations des Etats membres relatives à la compatibilité électromagnétique. Lenovo décline toute responsabilité en cas de non-respect de cette directive résultant d'une modification non recommandée du produit, y compris l'ajout de cartes en option non Lenovo.

Ce produit respecte les limites des caractéristiques d'immunité des appareils de traitement de l'information définies par la classe B de la norme européenne EN 55022 (CISPR 22). La conformité aux spécifications de la classe B offre une garantie acceptable contre les perturbations avec les appareils de communication agréés, dans les zones résidentielles.

## Unión Europea - Normativa EMC

Este producto satisface los requisitos de protección del Consejo de la UE, Directiva 2004/108/EC en lo que a la legislación de los Estados Miembros sobre compatibilidad electromagnética se refiere.

Lenovo no puede aceptar responsabilidad alguna si este producto deja de satisfacer dichos requisitos de protección como resultado de una modificación no recomendada del producto, incluyendo el ajuste de tarjetas de opción que no sean Lenovo.

Este producto ha sido probado y satisface los límites para Equipos Informáticos Clase B de conformidad con el Estándar Europeo EN 55022. Los límites para los equipos de Clase B se han establecido para entornos residenciales típicos a fin de proporcionar una protección razonable contra las interferencias con dispositivos de comunicación licenciados.

## Unione Europea - Directiva EMC (Conformidad elettromagnética)

Questo prodotto è conforme alle normative di protezione ai sensi della Direttiva del Consiglio dell'Unione Europea 2004/108/EC sull'armonizzazione legislativa degli stati membri in materia di compatibilità elettromagnetica.

Lenovo non accetta responsabilità alcuna per la mancata conformità alle normative di protezione dovuta a modifiche non consigliate al prodotto, compresa l'installazione di schede e componenti di marca diversa da Lenovo.

Le prove effettuate sul presente prodotto hanno accertato che esso rientra nei limiti stabiliti per le apparecchiature di informatica Classe B ai sensi della Norma Europea EN 55022. I limiti delle apparecchiature della Classe B sono stati stabiliti al fine di fornire ragionevole protezione da interferenze mediante dispositivi di comunicazione in concessione in ambienti residenziali tipici.

## Japan VCCI Class B compliance statement

この装置は、クラスB情報技術装置です。この装置は、家庭環境で使用することを目的としていますが、この装置がラジオやテレビジョン受信機に近接して使用されると、受信障害を引き起こすことがあります。  
取扱説明書に従って正しい取り扱いをして下さい。 VCCI-B

## Korea Class B compliance statement

<b>B급 기기 (가정용 방송통신기자재)</b>
이 기기는 가정용(B급) 전자파적합기기로서 주로 가정에서 사용하는 것을 목적으로 하며, 모든 지역에서 사용할 수 있습니다

## Notice for users in Korea

Note that this device has been certified for residential use and may be used in any environment.

해당 무선설비가 전파혼신 가능성이 있으므로 인명안전과 관련된 서비스는 할 수 없습니다

## Lenovo product service information for Taiwan

台灣 Lenovo 產品服務資訊如下：  
荷蘭商聯想股份有限公司台灣分公司  
台北市信義區信義路五段七號十九樓之一  
服務電話：0800-000-702

## Europe - EU Declaration of Conformity for ThinkPad Bluetooth Laser Mouse



Products intended for sale within the European Union are marked with the Conformité Européenne (CE) Marking, which indicates compliance with the applicable Directives and European Norms, and amendments, identified below.

Hereby, **Lenovo (Singapore) Pte. Ltd.**, declares that this **ThinkPad Bluetooth Laser Mouse** is in compliance with the essential requirements and other relevant provisions of Directive 1999/5/EC.

**Lenovo (Singapore) Pte. Ltd.** tímto prohlašuje, že tento **ThinkPad Bluetooth Laser Mouse** je ve shodě se základními požadavky a dalšími příslušnými ustanoveními směrnice 1999/5/ES.

Undertegnede **Lenovo (Singapore) Pte. Ltd.** erklærer herved, at følgende udstyr **ThinkPad Bluetooth Laser Mouse** overholder de væsentlige krav og øvrige relevante krav i direktiv 1999/5/EF.

Hiermit erkläre **Lenovo (Singapore) Pte. Ltd.**, dass sich das Gerät **ThinkPad Bluetooth Laser Mouse** in Übereinstimmung mit den grundlegenden Anforderungen und den übrigen einschlägigen Bestimmungen der Richtlinie 1999/5/EG befindet.

Käesolevaga kinnitab **Lenovo (Singapore) Pte. Ltd.** seadme **ThinkPad Bluetooth Laser Mouse** vastavust direktiivi 1999/5/EÜ põhinõuetele ja nimetatud direktiivist tulenevatele teistele asjakohastele sätetele. Richtlinie 1999/5/EG befindet.

Por medio de la presente **Lenovo (Singapore) Pte. Ltd.** declara que el **ThinkPad Bluetooth Laser Mouse** cumple con los requisitos esenciales y cualesquiera otras disposiciones aplicables o exigibles de la Directiva 1999/5/CE.

ΜΕ ΤΗΝ ΠΑΡΟΥΣΑ **Lenovo (Singapore) Pte. Ltd.** ΔΗΛΩΝΕΙ ΟΤΙ **ThinkPad Bluetooth Laser Mouse** ΣΥΜΜΟΡΦΩΝΕΤΑΙ ΠΡΟΣ ΤΙΣ ΟΥΣΙΩΔΕΙΣ ΑΠΑΙΤΗΣΕΙΣ ΚΑΙ ΤΙΣ ΛΟΙΠΕΣ ΣΧΕΤΙΚΕΣ ΔΙΑΤΑΞΕΙΣ ΤΗΣ ΟΔΗΓΙΑΣ 1999/5/ΕΚ.

Par la présente **Lenovo (Singapore) Pte. Ltd.** déclare que l'appareil **ThinkPad Bluetooth Laser Mouse** est conforme aux exigences essentielles et aux autres dispositions pertinentes de la directive 1999/5/CE.

Con la presente **Lenovo (Singapore) Pte. Ltd.** dichiara che questo **ThinkPad Bluetooth Laser Mouse** è conforme ai requisiti essenziali ed alle altre disposizioni pertinenti stabilite dalla direttiva 1999/5/CE.

Ar šo **Lenovo (Singapore) Pte. Ltd.** deklarē, ka **ThinkPad Bluetooth Laser Mouse** atbilst Direktīvas 1999/5/EK būtiskajām prasībām un citiem ar to saistītajiem noteikumiem.

Šiuo **Lenovo (Singapore) Pte. Ltd.** deklaruoja, kad šis **ThinkPad Bluetooth Laser Mouse** atitinka esminius reikalavimus ir kitas 1999/5/EB Direktyvos nuostatas.

Hierbij verklaart **Lenovo (Singapore) Pte. Ltd.** dat het toestel **ThinkPad Bluetooth Laser Mouse** in overeenstemming is met de essentiële eisen en de andere relevante bepalingen van richtlijn 1999/5/EG.

Hawnhekk, **Lenovo (Singapore) Pte. Ltd.**, jiddikjara li dan **ThinkPad Bluetooth Laser Mouse** jikkonforma mal-ħtiġijiet essenzjali u ma provvedimenti oħrajn relevanti li hemm fid-Dirrettiva 1999/5/EC.

Alulírott, **Lenovo (Singapore) Pte. Ltd.** nyilatkozom, hogy a **ThinkPad Bluetooth Laser Mouse** megfelel a vonatkozó alapvető követelményeknek és az 1999/5/EC irányelv egyéb előírásainak.

Niniejszym **Lenovo (Singapore) Pte. Ltd.** oświadcza, że **ThinkPad Bluetooth Laser Mouse** jest zgodny z zasadniczymi wymogami oraz pozostałymi stosownymi postanowieniami Dyrektywy 1999/5/EC.

**Lenovo (Singapore) Pte. Ltd.** declara que este **ThinkPad Bluetooth Laser Mouse** está conforme com os requisitos essenciais e outras disposições da Directiva 1999/5/CE.

**Lenovo (Singapore) Pte. Ltd.** izjavlja, da je ta **ThinkPad Bluetooth Laser Mouse** v skladu z bistvenimi zahtevami in ostalimi relevantnimi določili direktive 1999/5/ES.

**Lenovo (Singapore) Pte. Ltd.** týmto vyhlasuje, že **ThinkPad Bluetooth Laser Mouse** spĺňa základné požiadavky a všetky príslušné ustanovenia Smernice 1999/5/ES.

**Lenovo (Singapore) Pte. Ltd.** vakuuttaa täten että **ThinkPad Bluetooth Laser Mouse** tyypinen laite on direktiivin 1999/5/EY oleellisten vaatimusten ja sitä koskevien direktiivin muiden ehtojen mukainen.

Härmed intygar **Lenovo (Singapore) Pte. Ltd.** att denna **ThinkPad Bluetooth Laser Mouse** står i överensstämmelse med de väsentliga egenskapskrav och övriga relevanta bestämmelser som framgår av

Hér með lýsir **Lenovo (Singapore) Pte. Ltd.** yfir því að **ThinkPad Bluetooth Laser Mouse** er í samræmi við grunnkröfur og aðrar kröfur, sem gerðar eru í tilskipun 1999/5/EC.

**Lenovo (Singapore) Pte. Ltd.** erklærer herved at utstyret **ThinkPad Bluetooth Laser Mouse** er i samsvar med de grunnleggende krav og øvrige relevante krav i direktiv 1999/5/EF.

## Indonesia - ThinkPad Bluetooth Laser Mouse

12142/POSTEL/2009  
2029

## Israel - ThinkPad Bluetooth Laser Mouse

MOC: 51-15173

## Japan - ThinkPad Bluetooth Laser Mouse

ThinkPad Bluetooth Laser Mouse を日本国内でご使用になる際の注意

本製品が装備する無線装置は電波法に基づき技術基準認証を取得している機器です。

マウス

認証製品名： MOBTC9LA  
認証申請者名： Primax Electronics Ltd.  
認証番号： XXXXXXXX/AA/00

電波干渉についての注意

この機器の使用周波数帯では、電子レンジ等の産業・科学・医療用機器のほか工場の製造ライン等で使用されている移動体識別用の構内無線局（免許を要する無線局）及び特定小電力無線局（免許を要しない無線局）が運用されています。

- 1 この機器を使用する前に、近くで移動体識別用の構内無線局及び特定小電力無線局が運用されていないことを確認して下さい。
- 2 万一、この機器から移動体識別用の構内無線局に対して電波干渉の事例が発生した場合には、速やかに使用周波数を変更するか又は電波の発射を停止した上、下記連絡先にご連絡頂き、混信回避のための処置等(例えば、パーティションの設置など)についてご相談して下さい。
- 3 その他、この機器から移動体識別用の特定小電力無線局に対して電波干渉の事例が発生した場合など何かお困りのことが起きたときは、次の連絡先へお問い合わせ下さい。

連絡先： スマートセンター

スマートセンターのご利用方法は、次のホームページでご確認頂けます。

<http://www.ibm.com/jp/pc/support/contact/smartctr/>



この無線装置が、2.4GHz周波数帯(2400MHz～2483.5MHz)を使用する直接拡散変調方式の無線設備で、干渉距離が約10mであることを意味しています。

以上の内容は、「社団法人 電波産業界」 ARIB STD-T66の趣旨に基づくものです。

## South Africa - ThinkPad Bluetooth Laser Mouse



## ThinkPad Bluetooth Laser Mouse Taiwan NCC ID:



## Europe - EU Declaration of Conformity for Lenovo Laser Wireless Mouse



Products intended for sale within the European Union are marked with the Conformité Européenne (CE) Marking, which indicates compliance with the applicable Directives and European Norms, and amendments, identified below.

Hereby, **Lenovo (Singapore) Pte. Ltd.**, declares that this **Lenovo Laser Wireless Mouse** is in compliance with the essential requirements and other relevant provisions of Directive 1999/5/EC.

**Lenovo (Singapore) Pte. Ltd.** tímto prohlašuje, že tento **Lenovo Laser Wireless Mouse** je ve shodě se základními požadavky a dalšími příslušnými ustanoveními směrnice 1999/5/ES.

Undertegnede **Lenovo (Singapore) Pte. Ltd.** erklærer herved, at følgende udstyr **Lenovo Laser Wireless Mouse** overholder de væsentlige krav og øvrige relevante krav i direktiv 1999/5/EF.

Käesolevaga kinnitab **Lenovo (Singapore) Pte. Ltd.** seadme **Lenovo Laser Wireless Mouse** vastavust direktiivi 1999/5/EÜ põhinõuetele ja nimetatud direktiivist tulenevatele teistele asjakohastele sätetele. Richtlinie 1999/5/EG befindet.

**Lenovo (Singapore) Pte. Ltd.** vakuuttaa täten että **Lenovo Laser Wireless Mouse** tyypinen laite on direktiivin 1999/5/EY oleellisten vaatimusten ja sitä koskevien direktiivin muiden ehtojen mukainen.

ΜΕ ΤΗΝ ΠΑΡΟΥΣΑ **Lenovo (Singapore) Pte. Ltd.** ΔΗΛΩΝΕΙ ΟΤΙ **Lenovo Laser Wireless Mouse** ΣΥΜΜΟΡΦΟΝΕΤΑΙ ΠΡΟΣ ΤΙΣ ΟΥΣΙΩΔΕΙΣ ΑΠΑΙΤΗΣΕΙΣ ΚΑΙ ΤΙΣ ΛΟΙΠΕΣ ΣΧΕΤΙΚΕΣ ΔΙΑΤΑΞΕΙΣ ΤΗΣ ΟΔΗΓΙΑΣ 1999/5/EK.

Hiermit erklärt **Lenovo (Singapore) Pte. Ltd.**, dass sich das Gerät **Lenovo Laser Wireless Mouse** in Übereinstimmung mit den grundlegenden Anforderungen und den übrigen einschlägigen Bestimmungen der Richtlinie 1999/5/EG befindet.

Alulírott, **Lenovo (Singapore) Pte. Ltd.** nyilatkozom, hogy a **Lenovo Laser Wireless Mouse** megfelel a vonatkozó alapvető követelményeknek és az 1999/5/EC irányelv egyéb előírásainak.

Hér með lýsir **Lenovo (Singapore) Pte. Ltd.** yfir því að **Lenovo Laser Wireless Mouse** er í samræmi við grunnkröfur og aðrar kröfur, sem gerðar eru í tilskipun 1999/5/EC.

Con la presente **Lenovo (Singapore) Pte. Ltd.** dichiara che questo **Lenovo Laser Wireless Mouse** è conforme ai requisiti essenziali ed alle altre disposizioni pertinenti stabilite dalla direttiva 1999/5/CE.

Šiuo **Lenovo (Singapore) Pte. Ltd.** deklaruoją, kad šis **Lenovo Laser Wireless Mouse** atitinka esminius reikalavimus ir kitas 1999/5/EB Direktyvos nuostatas.

Ar šo **Lenovo (Singapore) Pte. Ltd.** deklarē, ka **Lenovo Laser Wireless Mouse** atbilst Direktīvas 1999/5/EK būtiskajām prasībām un citiem ar to saistītajiem noteikumiem.

Hawnhekk, **Lenovo (Singapore) Pte. Ltd.**, jiddikjara li dan **Lenovo Laser Wireless Mouse** jikkonforma mal-htigijiet essenzjali u ma provvedimenti oħrajn relevanti li hemm fid-Dirrettiva 1999/5/EC.

Hierbij verklaart **Lenovo (Singapore) Pte. Ltd.** dat het toestel **Lenovo Laser Wireless Mouse** in overeenstemming is met de essentiële eisen en de andere relevante bepalingen van richtlijn 1999/5/EG.

**Lenovo (Singapore) Pte. Ltd.** erklærer herved at udstyret **Lenovo Laser Wireless Mouse** er i samsvar med de grunnleggende krav og øvrige relevante krav i direktiv 1999/5/EF.

Niniejszym **Lenovo (Singapore) Pte. Ltd.** oświadcza, że **Lenovo Laser Wireless Mouse** jest zgodny z zasadniczymi wymogami oraz pozostałymi stosownymi postanowieniami Dyrektywy 1999/5/EC.

**Lenovo (Singapore) Pte. Ltd.** týmto vyhlasuje, že **Lenovo Laser Wireless Mouse** spĺňa základné požiadavky a všetky príslušné ustanovenia Smernice 1999/5/ES.

**Lenovo (Singapore) Pte. Ltd.** izjavlja, da je ta **Lenovo Laser Wireless Mouse** v skladu z bistvenimi zahtevami in ostalimi relevantnimi določili direktive 1999/5/ES.

Por medio de la presente **Lenovo (Singapore) Pte. Ltd.** declara que el **Lenovo Laser Wireless Mouse** cumple con los requisitos esenciales y cualesquiera otras disposiciones aplicables o exigibles de la Directiva 1999/5/CE.

Härmed intygar **Lenovo (Singapore) Pte. Ltd.** att denna **Lenovo Laser Wireless Mouse** står i överensstämmelse med de väsentliga egenskapskrav och övriga relevanta bestämmelser som framgår av direktiv 1999/5/EG.

**Lenovo (Singapore) Pte. Ltd.** declara que este **Lenovo Laser Wireless Mouse** está conforme com os requisitos essenciais e outras disposições da Directiva 1999/5/CE.

Par la présente **Lenovo (Singapore) Pte. Ltd.** déclare que l'appareil **Lenovo Laser Wireless Mouse** est conforme aux exigences essentielles et aux autres dispositions pertinentes de la directive 1999/5/CE.



### EC Declaration of Conformance

Product: **Lenovo Ultralim Wireless Plus Keyboard and Mouse**

Models:

Name	Model	P/N
Wireless Mouse	MOBTC9LA	0A34282

Trade Name: **Lenovo**

We, **Primax Electronics Ltd.**, declare under sole responsibility that the above products, manufactured by:

**Primax Electronics Ltd.**  
No. 669, Ruyi Kuang Road,  
Neihu, Taipei Taiwan  
Phone: 886(2)2798 9008  
Fax: 886(2) 8797 1565

to which this declaration relates, is in conformity with the requirements of the following EC Directives:

- Council Directive 1999/5/EC of the European Parliament and of the council on radio equipment and telecommunications terminal equipment.
- Council Directive 2006/95/EC on the harmonization of the laws of the Member States relating to electronic equipment designed for use within certain voltage limits.
- Council Directive 2004/108/EC on the approximation of the laws of the member states relating to Electromagnetic Compatibility

Conformity with these Directives has been assessed for this product by demonstrating compliance to the following harmonized standards:

EN 300 440-1 V1.4.1 (2008-05)  
EN 300 440-2 V1.4.1 (2010-08)  
EN 301 489-1 V1.8.1 (2008-04)  
EN 301 489-3 V1.4.1 (2002-08)  
EN 50371: 2002  
EN 60950-1:2006 +A11:2009,  
EN 60825-1:2007

Signed: C.T. Huang Date: 2011/02/23  
C.T. Huang, Director  
Compliance Department

Last two digits of the year in which the CE marking was affixed: 11

Place of Issue: Taiwan  
Date: February 23, 2011  
Ref No: CE\_DoC\_11-005a



**Singapore IDA Certificate**

Complies with  
IDA Standards  
DA104328

**Brazil - Lenovo Laser Wireless Mouse**



**Brazil - Dongle for Lenovo Laser Wireless Mouse**



**For model: MORFFHL and MORFFHL-D**

Portuguese	Este equipamento opera em caráter secundário, isto é, não tem direito a proteção contra interferência prejudicial, mesmo de estações do mesmo tipo, e não pode causar interferência a sistemas operando em caráter primário.
English	This equipment is a secondary type device, that is, it is not protected against harmful interference, even if the interference is caused by a device of the same type, and it also cannot cause any interference to primary type devices.

**India - Lenovo Laser Wireless Mouse**

ETA-1073/2011/WRLO

**India - Dongle for Lenovo Laser Wireless Mouse**

ETA-1072/2011/WRLO

**Indonesia - Lenovo Laser Wireless Mouse**

19099/SDPPI/2011  
2029

**Indonesia - Dongle for Lenovo Laser Wireless Mouse**

19100/SDPPI/2011  
2029

For model MORFFHL-D:

TRA  
REGISTERED No.  
ER0062912/11  
DEALER No.  
DA0042866/10

## Saudi Arabia - Lenovo Laser Wireless Mouse

معلومات مقدم الطلب	
Applicant:	TVU Rheinland Arabia (TURA)
Order Date:	16/03/2011
Contact Info:	صندوق البريد P.O.BOX بريد الكتروني E-Mail
بيانات الجهاز	
Product Name:	Lenovo Wireless Mouse
Product Model:	MORFFHL
Manufacturer:	Primax Electronic Ltd
معلومات إضافية	
Operating Frequency Range:	2400-2483.5 MHz
Maximum Output Power allowed (EIRP):	1 mW
بيانات الشهادة	
Issue Date:	22/03/2011
Validity Period:	One Year
Device comply with CITC technical Specification No.:	RI054
Additional Requirement	-

بناءً على نظام الاتصالات الصادر بالمرسوم الملكي ذي الرقم (١٢/م) والتاريخ ١٤٣٢/٠٣/١٢هـ ولألحته التنفيذية، وبموجب تنظيم هيئة الاتصالات وتقنية المعلومات بقرار مجلس الوزراء رقم (٧٤) والتاريخ ١٤٣٢/٠٣/٠٩هـ، فقد أصدرت الهيئة هذه الوثيقة بخصوص مطابقة الجهاز المشار إليه أعلاه، علماً بأن هذه الوثيقة لا تعتبر موافقة على فتح الأجهزة المشار إليها أعلاه أو الترخيص باستخدامها، بل هي شهادة مطابقة للمواصفات الفنية المعمول بها بالهيئة، كما أن هذه الشهادة قد صدرت عن الهيئة بناءً على المعلومات المتاحة لها والتي وفرتها الجهة المستوردة أو المصنعة وقت صدور هذه الشهادة، ولا يجوز استخدام أو حيازة الأجهزة أو المتاجرة بها بصورة تخالف أحكام وانظمة هيئة الاتصالات وتقنية المعلومات والأنظمة الأخرى ذات العلاقة المعمول بها في المملكة، وتتحمل الجهة المستوردة أو المصنعة وحدها المسؤولية عن أية أضرار أو خسائر أو إصابات قد تنشأ عن حيازة أو استخدام هذه الأجهزة أو المتاجرة بها. وبج حال تكون الأجهزة مصنعة خارج المملكة فإنه يجب التقدم إلى الهيئة من قبل المستورد بطلب لفتح الأجهزة قبل وقت وصولها إلى أحد المنافذ الجمركية.

اعتماد الشهادة

صدرت من قبل قطاع الشؤون الفنية - إدارة المعايير الفنية واعتماد النوعية

المستوردين الفنيين  
TECHNICAL AFFAIRS  
Communications and Information Technology Commission

ص ب ٧٥٦٠٦ الرياض ١١٥٨٨ - المملكة العربية السعودية - هاتف: ٤٦١٨٠٠٠ (٩٦٦-١) - فاكس: ٤٦١٨١٢٠ (٩٦٦-١) - الموقع الإلكتروني: www.citc.gov.sa  
P.O.Box:75606 Riyadh11588 Kingdom of Saudi Arabia - Tel:(966-1)4618000 - Fax:(966-1)4618120 - Web Site: www.citc.gov.sa

---

## Appendix D. Notices

Lenovo may not offer the products, services, or features discussed in this document in all countries. Consult your local Lenovo representative for information on the products and services currently available in your area. Any reference to a Lenovo product, program, or service is not intended to state or imply that only that Lenovo product, program, or service may be used. Any functionally equivalent product, program, or service that does not infringe any Lenovo intellectual property right may be used instead. However, it is the user's responsibility to evaluate and verify the operation of any other product, program, or service.

Lenovo may have patents or pending patent applications covering subject matter described in this document. The furnishing of this document does not give you any license to these patents. You can send license inquiries, in writing, to:

*Lenovo (United States), Inc.  
1009 Think Place - Building One  
Morrisville, NC 27560  
U.S.A.  
Attention: Lenovo Director of Licensing*

LENOVO PROVIDES THIS PUBLICATION "AS IS" WITHOUT WARRANTY OF ANY KIND, EITHER EXPRESS OR IMPLIED, INCLUDING, BUT NOT LIMITED TO, THE IMPLIED WARRANTIES OF NON-INFRINGEMENT, MERCHANTABILITY OR FITNESS FOR A PARTICULAR PURPOSE. Some jurisdictions do not allow disclaimer of express or implied warranties in certain transactions, therefore, this statement may not apply to you.

This information could include technical inaccuracies or typographical errors. Changes are periodically made to the information herein; these changes will be incorporated in new editions of the publication. Lenovo may make improvements and/or changes in the product(s) and/or the program(s) described in this publication at any time without notice.

---

## Trademarks

The following terms are trademarks of Lenovo in the United States, other countries, or both:

Lenovo  
ScrollPoint  
The Lenovo logo  
ThinkPad

Microsoft, Windows, and Windows Vista are trademarks of the Microsoft group of companies.

Other company, product, or service names may be trademarks or service marks of others.

---

## Recycling information

Lenovo encourages owners of information technology (IT) equipment to responsibly recycle their equipment when it is no longer needed. Lenovo offers a variety of programs and services to assist equipment owners in recycling their IT products. For information on recycling Lenovo products, go to:  
<http://www.lenovo.com/recycling>

Recycling and disposal information for Japan is available at:  
<http://www.lenovo.com/recycling/japan>

---

## **Recycling information for Brazil**

### **Declarações de Reciclagem no Brasil**

#### **Descarte de um Produto Lenovo Fora de Uso**

Equipamentos elétricos e eletrônicos não devem ser descartados em lixo comum, mas enviados à pontos de coleta, autorizados pelo fabricante do produto para que sejam encaminhados e processados por empresas especializadas no manuseio de resíduos industriais, devidamente certificadas pelos órgãos ambientais, de acordo com a legislação local.

A Lenovo possui um canal específico para auxiliá-lo no descarte desses produtos. Caso você possua um produto Lenovo em situação de descarte, ligue para o nosso SAC ou encaminhe um e-mail para: [reciclar@lenovo.com](mailto:reciclar@lenovo.com), informando o modelo, número de série e cidade, a fim de enviarmos as instruções para o correto descarte do seu produto Lenovo.

Este equipamento opera em caráter secundário, isto é, não tem direito a proteção contra interferência prejudicial, mesmo de estações do mesmo tipo, e não pode causar interferência a sistemas operando em caráter primário.

---

## Appendix E. Restriction of Hazardous Substances Directive (RoHS)

---

### China RoHS

The information in the following table is applicable for products manufactured on or after March 1, 2007 for sale in the People's Republic of China.

Lenovo 电脑选件	有毒有害物质或元素					
	铅 (Pb)	汞 (Hg)	镉 (Cd)	六价铬 (Cr(VI))	多溴联苯 (PBB)	多溴二苯醚 (PBDE)
鼠标	X	O	O	O	O	O

O：表示该有毒有害物质在该部件所有均质材料中的含量均在SJ/T 11363-2006标准规定的限量要求以下。  
X：表示该有毒有害物质至少在该部件的某一均质材料中的含量超出SJ/T 11363-2006标准规定的限量要求。  
对于销往欧盟的产品，标有“X”的项目均符合欧盟指令2002/95/EC 豁免条款。

 在中华人民共和国境内销售的电子信息产品上将印有“环保使用期”(EUP)符号。圆圈中的数字代表产品的正常环保使用年限。

---

### Turkish statement of compliance

The Lenovo product meets the requirements of the Republic of Turkey Directive on the Restriction of the Use of Certain Hazardous Substances in Electrical and Electronic Equipment (EEE).

#### Türkiye EEE Yönetmeliğine Uygunluk Beyanı

Bu Lenovo ürünü, T.C. Çevre ve Orman Bakanlığı'nın "Elektrik ve Elektronik Eşyalarda Bazı Zararlı Maddelerin Kullanımının Sınırlandırılmasına Dair Yönetmelik (EEE)" direktiflerine uygundur.

EEE Yönetmeliğine Uygundur.

---

### Ukraine RoHS

Цим підтверджуємо, що продукція Леново відповідає вимогам нормативних актів України, які обмежують вміст небезпечних речовин





**lenovo**<sup>®</sup>