

FCC Test Report

Report No.: RFBDKX-WTW-P21080422

FCC ID: EMJMAW720M

Test Model: AW720M

Received Date: 2021/8/23

Test Date: 2021/8/25 ~ 2021/9/9

Issued Date: 2021/9/23

Applicant: PRIMAX ELECTRONICS LTD.

Address: No. 669, Ruey Kuang Road, Neihu, Taipei, Taiwan, R.O.C.

Issued By: Bureau Veritas Consumer Products Services (H.K.) Ltd., Taoyuan Branch
Lin Kou Laboratories

Lab Address: No. 47-2, 14th Ling, Chia Pau Vil., Lin Kou Dist., New Taipei City, Taiwan

**FCC Registration /
Designation Number:** 198487 / TW2021



This report is for your exclusive use. Any copying or replication of this report to or for any other person or entity, or use of our name or trademark, is permitted only with our prior written permission. This report sets forth our findings solely with respect to the test samples identified herein. The results set forth in this report are not indicative or representative of the quality or characteristics of the lot from which a test sample was taken or any similar or identical product unless specifically and expressly noted. Our report includes all of the tests requested by you and the results thereof based upon the information that you provided to us. You have 60 days from date of issuance of this report to notify us of any material error or omission caused by our negligence, provided, however, that such notice shall be in writing and shall specifically address the issue you wish to raise. A failure to raise such issue within the prescribed time shall constitute your unqualified acceptance of the completeness of this report, the tests conducted and the correctness of the report contents. Unless specific mention, the uncertainty of measurement has been explicitly taken into account to declare the compliance or non-compliance to the specification.

Table of Contents

| | |
|---|-----------|
| Release Control Record | 3 |
| 1 Certificate of Conformity | 4 |
| 2 Summary of Test Results | 5 |
| 2.1 Measurement Uncertainty..... | 5 |
| 2.2 Modification Record..... | 5 |
| 3 General Information | 6 |
| 3.1 General Description of EUT..... | 6 |
| 3.2 Description of Test Modes..... | 7 |
| 3.2.1 Test Mode Applicability and Tested Channel Detail..... | 8 |
| 3.3 Duty Cycle of Test Signal..... | 9 |
| 3.4 Description of Support Units..... | 10 |
| 3.4.1 Configuration of System under Test..... | 10 |
| 3.5 General Description of Applied Standards..... | 11 |
| 4 Test Types and Results | 12 |
| 4.1 Radiated Emission and Bandedge Measurement..... | 12 |
| 4.1.1 Limits of Radiated Emission and Bandedge Measurement..... | 12 |
| 4.1.2 Test Instruments..... | 13 |
| 4.1.3 Test Procedures..... | 14 |
| 4.1.4 Deviation from Test Standard..... | 14 |
| 4.1.5 Test Setup..... | 15 |
| 4.1.6 EUT Operating Conditions..... | 16 |
| 4.1.7 Test Results..... | 17 |
| 4.2 Conducted Emission Measurement..... | 23 |
| 4.2.1 Limits of Conducted Emission Measurement..... | 23 |
| 4.2.2 Test Instruments..... | 23 |
| 4.2.3 Test Procedures..... | 24 |
| 4.2.4 Deviation From Test Standard..... | 24 |
| 4.2.5 Test Setup..... | 24 |
| 4.2.6 EUT Operating Condition..... | 24 |
| 4.2.7 Test Results..... | 25 |
| 4.3 Channel Bandwidth..... | 29 |
| 4.3.1 Test Setup..... | 29 |
| 4.3.2 Test Instruments..... | 29 |
| 4.3.3 Test Procedure..... | 29 |
| 4.3.4 Deviation from Test Standard..... | 29 |
| 4.3.5 EUT Operating Condition..... | 29 |
| 4.3.6 Test Results..... | 30 |
| 5 Pictures of Test Arrangements | 31 |
| Appendix – Information of the Testing Laboratories | 32 |

Release Control Record

| Issue No. | Description | Date Issued |
|----------------------|-------------------|-------------|
| RFBDKX-WTW-P21080422 | Original release. | 2021/9/23 |

1 Certificate of Conformity

Product: Mouse

Brand: ALIENWARE

Test Model: AW720M

Sample Status: Engineering sample

Applicant: PRIMAX ELECTRONICS LTD.

Test Date: 2021/8/25 ~ 2021/9/9

Standards: 47 CFR FCC Part 15, Subpart C (Section 15.249)
ANSI C63.10: 2013

The above equipment has been tested by **Bureau Veritas Consumer Products Services (H.K.) Ltd., Taoyuan Branch**, and found compliance with the requirement of the above standards. The test record, data evaluation & Equipment Under Test (EUT) configurations represented herein are true and accurate accounts of the measurements of the sample's RF characteristics under the conditions specified in this report.

Prepared by :

Annie Chang

Date:

2021/9/23

Annie Chang / Senior Specialist

Approved by :

Rex Lai

Date:

2021/9/23

Rex Lai / Associate Technical Manager

2 Summary of Test Results

| 47 CFR FCC Part 15, Subpart C (SECTION 15.249) | | | |
|--|--|--------|--|
| FCC Clause | Test Item | Result | Remarks |
| 15.207 | AC Power Conducted Emission | PASS | Meet the requirement of limit. Minimum passing margin is -9.84dB at 0.52290MHz. |
| 15.215 | Channel Bandwidth Measurement | PASS | Meet the requirement of limit. |
| 15.209 15.249 | Radiated Emission Test Band Edge Measurement Limit: 50dB less than the peak value of fundamental frequency or meet radiated emission limit in section 15.209 | PASS | Meet the requirement of limit. Minimum passing margin is -11.42dB at 2441.00MHz. |
| 15.203 | Antenna Requirement | PASS | No antenna connector is used. |

Note: Determining compliance based on the results of the compliance measurement, not taking into account measurement instrumentation uncertainty.

2.1 Measurement Uncertainty

Where relevant, the following measurement uncertainty levels have been estimated for tests performed on the EUT as specified in CISPR 16-4-2:

| Measurement | Frequency | Expanded Uncertainty (k=2) (\pm) |
|------------------------------------|-----------------|--------------------------------------|
| Conducted Emissions at mains ports | 150kHz ~ 30MHz | 3.00 dB |
| Conducted Emissions | 9kHz ~ 40GHz | 2.63 dB |
| Radiated Emissions up to 1 GHz | 9kHz ~ 30MHz | 2.38 dB |
| | 30MHz ~ 1000MHz | 5.70 dB |
| Radiated Emissions above 1 GHz | Above 1GHz | 5.14 dB |

2.2 Modification Record

There were no modifications required for compliance.

3 General Information

3.1 General Description of EUT

| | |
|---------------------|---|
| Product | Mouse |
| Brand | ALIENWARE |
| Test Model | AW720M |
| Status of EUT | Engineering sample |
| Power Supply Rating | 5Vdc from host equipment or 3.7Vdc from battery |
| Modulation Type | GFSK |
| Operating Frequency | 2402MHz ~ 2479MHz |
| Number of Channel | 78 |
| Field Strength | 80.35dBuV/m (3m) |
| Antenna Type | PCB antenna with 0.76 dBi gain |
| Antenna Connector | N/A |
| Accessory Device | USB adapter, Connector |
| Data Cable Supplied | Shielded USB cable (2.0m) |

Note:

1. Bluetooth & GFSK technologies can not transmit at same time.

2. The EUT uses following rechargeable battery.

| | |
|--------------|---|
| Manufacturer | Hangzhou Future Power Technology Co., Ltd |
| Model | FT382944P |
| Rating | 3.7Vdc |

3. For Radiated Emissions test, following modes were pre-tested:

- ✧ Operating Mode (Powered from Battery)
- ✧ Operating + Charging Mode (Powered from Adapter)
- ✧ Operating + Charging Mode (Powered from Notebook)
- ✧ Operating with Dongle + Charging Mode (Powered from Notebook)

The worst emission level was found when the EUT tested under **Operating + Charging Mode (Powered from Notebook)**, therefore, only its test data was recorded in this report.

4. The above EUT information is declared by manufacturer and for more detailed features description, please refers to the manufacturer's specifications or user's manual.

3.2 Description of Test Modes

78 channels are provided to this EUT:

| CHANNEL | FREQ. (MHz) | CHANNEL | FREQ. (MHz) | CHANNEL | FREQ. (MHz) | CHANNEL | FREQ. (MHz) |
|---------|-------------|---------|-------------|---------|-------------|---------|-------------|
| 0 | 2402 | 20 | 2422 | 40 | 2442 | 60 | 2462 |
| 1 | 2403 | 21 | 2423 | 41 | 2443 | 61 | 2463 |
| 2 | 2404 | 22 | 2424 | 42 | 2444 | 62 | 2464 |
| 3 | 2405 | 23 | 2425 | 43 | 2445 | 63 | 2465 |
| 4 | 2406 | 24 | 2426 | 44 | 2446 | 64 | 2466 |
| 5 | 2407 | 25 | 2427 | 45 | 2447 | 65 | 2467 |
| 6 | 2408 | 26 | 2428 | 46 | 2448 | 66 | 2468 |
| 7 | 2409 | 27 | 2429 | 47 | 2449 | 67 | 2469 |
| 8 | 2410 | 28 | 2430 | 48 | 2450 | 68 | 2470 |
| 9 | 2411 | 29 | 2431 | 49 | 2451 | 69 | 2471 |
| 10 | 2412 | 30 | 2432 | 50 | 2452 | 70 | 2472 |
| 11 | 2413 | 31 | 2433 | 51 | 2453 | 71 | 2473 |
| 12 | 2414 | 32 | 2434 | 52 | 2454 | 72 | 2474 |
| 13 | 2415 | 33 | 2435 | 53 | 2455 | 73 | 2475 |
| 14 | 2416 | 34 | 2436 | 54 | 2456 | 74 | 2476 |
| 15 | 2417 | 35 | 2437 | 55 | 2457 | 75 | 2477 |
| 16 | 2418 | 36 | 2438 | 56 | 2458 | 76 | 2478 |
| 17 | 2419 | 37 | 2439 | 57 | 2459 | 77 | 2479 |
| 18 | 2420 | 38 | 2440 | 58 | 2460 | | |
| 19 | 2421 | 39 | 2441 | 59 | 2461 | | |

3.2.1 Test Mode Applicability and Tested Channel Detail

| EUT Configure Mode | Applicable To | | | | Description |
|--------------------|---------------|-------|-----|------|---|
| | RE \geq 1G | RE<1G | PLC | APCM | |
| A | √ | √ | √ | √ | Operating + Charging Mode (Powered from Notebook) |
| B | - | - | √ | - | Operating + Charging Mode (Powered from Adapter) |
| C | √ | - | - | - | Operating with Dongle + Charging Mode (Powered from Notebook) |

Where **RE \geq 1G**: Radiated Emission above 1GHz & Bandedge Measurement
RE<1G: Radiated Emission below 1GHz
PLC: Power Line Conducted Emission
APCM: Antenna Port Conducted Measurement

Radiated Emission Test (Above 1GHz):

- Pre-Scan has been conducted to determine the worst-case mode from all possible combinations between available modulations, data rates and antenna ports (if EUT with antenna diversity architecture).
- Following channel(s) was (were) selected for the final test as listed below.

| EUT Configure Mode | Available Channel | Tested Channel | Modulation Type |
|--------------------|-------------------|-------------------------|-----------------|
| A | 0 to 77 | 0, 39, 77 | GFSK |
| C | 0 to 77 | 0 (Mouse) + 39 (Dongle) | GFSK |

Radiated Emission Test (Below 1GHz):

- Pre-Scan has been conducted to determine the worst-case mode from all possible combinations between available modulations, data rates and antenna ports (if EUT with antenna diversity architecture).
- Following channel(s) was (were) selected for the final test as listed below.

| EUT Configure Mode | Available Channel | Tested Channel | Modulation Type |
|--------------------|-------------------|----------------|-----------------|
| A | 0 to 77 | 39 | GFSK |

Power Line Conducted Emission Test:

- Pre-Scan has been conducted to determine the worst-case mode from all possible combinations between available modulations, data rates and antenna ports (if EUT with antenna diversity architecture).
- Following channel(s) was (were) selected for the final test as listed below.

| EUT Configure Mode | Available Channel | Tested Channel | Modulation Type |
|--------------------|-------------------|----------------|-----------------|
| A & B | 0 to 77 | 39 | GFSK |

Antenna Port Conducted Measurement:

- This item includes all test value of each mode, but only includes spectrum plot of worst value of each mode.
- Pre-Scan has been conducted to determine the worst-case mode from all possible combinations between available modulations, data rates and antenna ports (if EUT with antenna diversity architecture).
- Following channel(s) was (were) selected for the final test as listed below.

| EUT Configure Mode | Available Channel | Tested Channel | Modulation Type |
|--------------------|-------------------|----------------|-----------------|
| A | 0 to 77 | 0, 39, 77 | GFSK |

Test Condition:

| Applicable To | EUT Configure Mode | Environmental Conditions | Input Power | Tested By |
|---------------|--------------------|--------------------------|------------------------|-----------|
| RE≥1G | A & C | 21deg. C, 68%RH | 120Vac, 60Hz (System) | Ian Chang |
| RE<1G | A | 21deg. C, 68%RH | 120Vac, 60Hz (System) | Ian Chang |
| PLC | A | 25deg. C, 75%RH | 120Vac, 60Hz (System) | Ian Chang |
| | B | 25deg. C, 75%RH | 120Vac, 60Hz (Adapter) | Ian Chang |
| APCM | A | 25deg. C, 76%RH | 120Vac, 60Hz (System) | Dalen Dai |

3.3 Duty Cycle of Test Signal

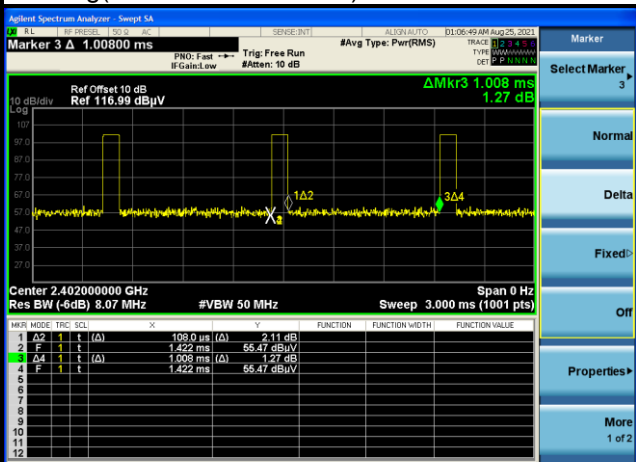
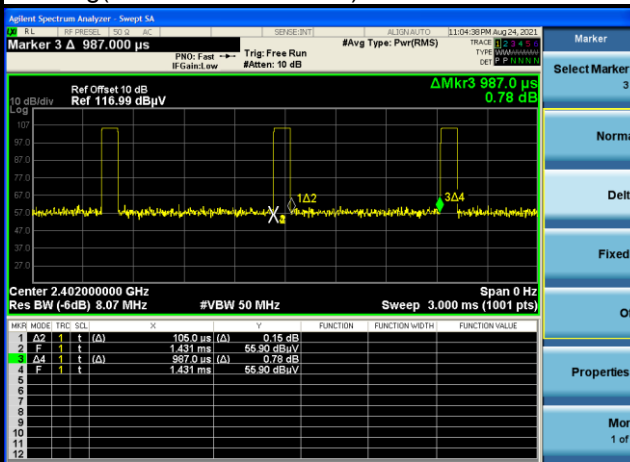
| Mouse | Dongle |
|--|---|
| <p>Duty Factor = 20 log(Duty cycle) = 20 log(0.108 ms / 1.008 ms) = -19.4dB</p>  | <p>Duty Factor = 20 log(Duty cycle) = 20 log(0.105 ms / 0.987 ms) = -19.5dB</p>  |

3.4 Description of Support Units

The EUT has been tested as an independent unit together with other necessary accessories or support units. The following support units or accessories were used to form a representative test configuration during the tests.

| ID | Product | Brand | Model No. | Serial No. | FCC ID | Remarks |
|----|-------------|-----------|-------------------|------------|-------------|--------------------|
| A. | Notebook PC | Lenovo | IdeaPad 5 15ITL05 | NA | NA | Provided by Lab |
| B. | Adapter | Apple | A1385 | NA | NA | Provided by Lab |
| C. | Dongle | ALIENWARE | UD2201p | NA | EMJDUD2201P | Supplied by client |

Note: All power cords of the above support units are non-shielded (1.8m).

| ID | Cable Descriptions | Qty. | Length (m) | Shielding (Yes/No) | Cores (Qty.) | Remarks |
|----|--------------------|------|------------|--------------------|--------------|--------------------|
| 1. | USB cable | 1 | 2.0 | Y | 0 | Supplied by client |

Note: The core(s) is(are) originally attached to the cable(s).

3.4.1 Configuration of System under Test

Mode A

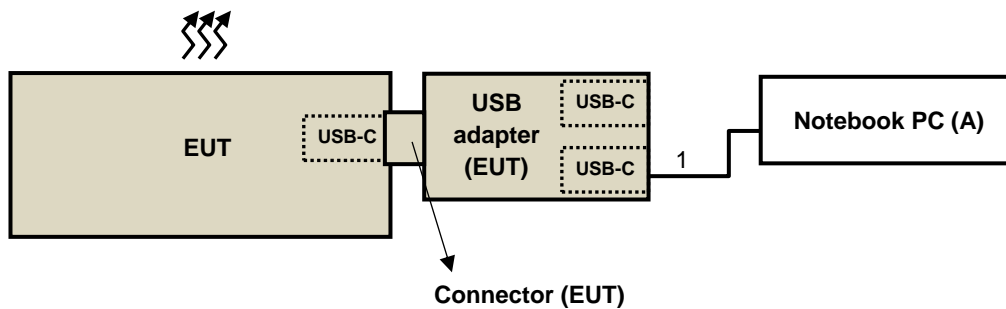

Mode B

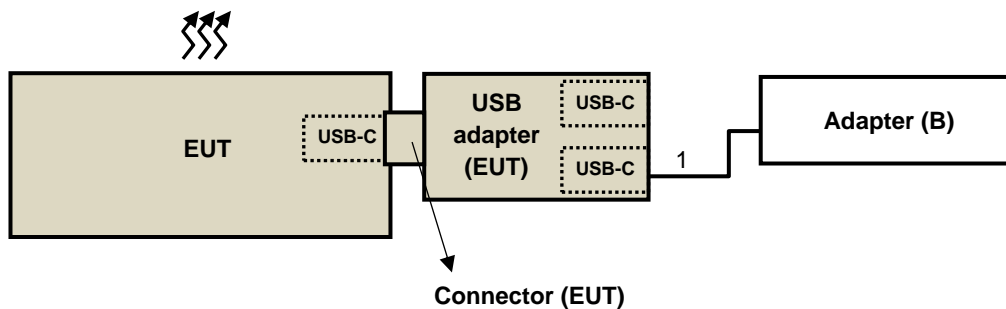

Mode C

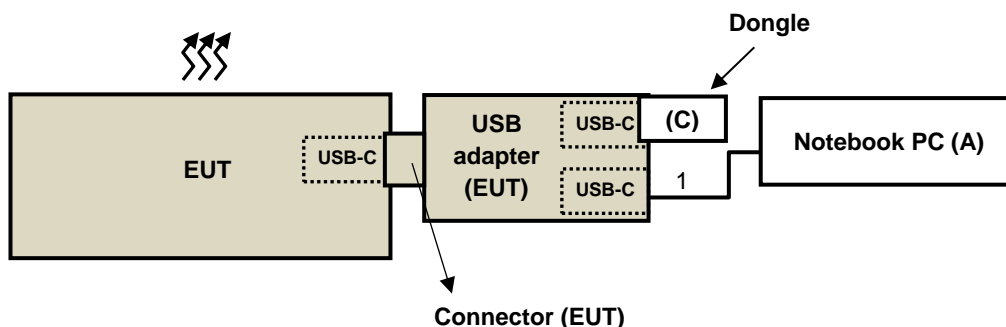

3.5 General Description of Applied Standards

The EUT is a RF Product. According to the specifications of the manufacturer, it must comply with the requirements of the following standards:

FCC Part 15, Subpart C (15.249)

ANSI C63.10-2013

All test items have been performed and recorded as per the above standards.

4 Test Types and Results

4.1 Radiated Emission and Bandedge Measurement

4.1.1 Limits of Radiated Emission and Bandedge Measurement

The field strength of emissions from intentional radiators operated within these frequency bands shall comply with the following

| Fundamental Frequency | Field Strength of Fundamental (millivolts/meter) | Field Strength of Harmonics (microvolts/meter) |
|-----------------------|--|--|
| 902 ~ 928 MHz | 50 | 500 |
| 2400 ~ 2483.5 MHz | 50 | 500 |
| 5725 ~ 5875 MHz | 50 | 500 |
| 24 ~ 24.25 GHz | 250 | 2500 |

Emissions radiated outside of the specified frequency bands, except for harmonics, shall be attenuated by at least 50 dB below the level of the fundamental or to the general radiated emission limits as below table, whichever is the lesser attenuation

| Frequencies (MHz) | Field Strength (microvolts/meter) | Measurement Distance (meters) |
|-------------------|-----------------------------------|-------------------------------|
| 0.009 ~ 0.490 | 2400/F(kHz) | 300 |
| 0.490 ~ 1.705 | 24000/F(kHz) | 30 |
| 1.705 ~ 30.0 | 30 | 30 |
| 30 ~ 88 | 100 | 3 |
| 88 ~ 216 | 150 | 3 |
| 216 ~ 960 | 200 | 3 |
| Above 960 | 500 | 3 |

NOTE:

1. The lower limit shall apply at the transition frequencies.
2. Emission level (dBuV/m) = 20 log Emission level (uV/m).
3. For frequencies above 1000MHz, the field strength limits are based on average detector, however, the peak field strength of any emission shall not exceed the maximum permitted average limits, specified above by more than 20dB under any condition of modulation.

4.1.2 Test Instruments

| Description & Manufacturer | Model no. | Serial No. | Calibrated Date | Calibrated Until |
|---|----------------------------------|-----------------------|-----------------|------------------|
| Test Receiver Agilent | N9038A | MY51210129 | 2021/3/12 | 2022/3/11 |
| Software BVADT | ADT_Radiated_V8.7.0 8 | NA | NA | NA |
| Software BVADT | ADT_RF Test Software V6.6.5.4 | NA | NA | NA |
| Auto Control System(Antenna Tower, Table, Controller) ADT | SC100+AT100+TT100 | 0306 | NA | NA |
| Pre_Amplifier EMCJ | EMC001340 | 980269 | 2021/6/29 | 2022/6/28 |
| LOOP ANTENNA EMCJ | EM-6879 | 269 | 2020/09/17 | 2021/09/16 |
| RF Coaxial Cable Pacific | 8D-FB | Cable-CH6-02 | 2021/7/13 | 2022/7/12 |
| Pre_Amplifier HP | 8447D | 2432A03504 | 2021/2/18 | 2022/2/17 |
| Bi-log Broadband Antenna Schwarzbeck | VULB9168 | 139 | 2020/11/6 | 2021/11/5 |
| Attenuator Mini-Circuits | UNAT-5+ | PAD-CH6-01 | 2021/7/13 | 2022/7/12 |
| RF Coaxial Cable Pacific | 8D-FB | Cable-CH6-02 | 2021/7/13 | 2022/7/12 |
| Antenna(Horn) EMCO | 3115 | 00028257 | 2020/11/22 | 2021/11/21 |
| Test Receiver Agilent | N9038A | MY51210129 | 2021/3/12 | 2022/3/11 |
| Pre-amplifier HP | 8449B | 3008A01201 | 2021/2/19 | 2022/2/18 |
| RF Coaxial Cable HUBER SUHNER | SF-102 | Cable-CH6-01 | 2021/7/8 | 2022/7/7 |
| Highpass filter Wainwright Instruments | WHK 3.1/18G-10SS | SN 8 | 2021/5/28 | 2022/5/27 |
| Fix tool for Boresight | BAF-01 | 5 | NA | NA |
| Pre_Amplifier MITEQ | AMF-6F-260400-33-8P | 892164 | 2021/2/19 | 2022/2/18 |
| Antenna(Horn) Schwarzbeck | BBHA-9170 | BBHA9170190 | 2020/11/22 | 2021/11/21 |
| Spectrum Analyzer R&S | FSV40 | 101544 | 2021/5/24 | 2022/5/23 |
| RF Coaxial Cable WOKEN | WC01 | Cable-CH10-03 | 2021/7/8 | 2022/7/7 |
| RF Coaxial Cable Rosnol | K1K50-UP0279- K1K50-3000 | Cable- CH10(3m)-04 | 2021/7/8 | 2022/7/7 |
| Highpass filter SUHNER | 11SH10-7000/T18000- O/OP | SN 4 | 2021/5/28 | 2022/5/27 |

- NOTE:**
1. The calibration interval of the above test instruments is 12 months. And the calibrations are traceable to NML/ROC and NIST/USA.
 2. The horn antenna and HP preamplifier (model: 8449B) are used only for the measurement of emission frequency above 1GHz if tested.
 3. The test was performed in LK - 966 chamber 1.
 4. Tested Date: 2021/8/25 ~ 2021/9/9

4.1.3 Test Procedures

For Radiated emission below 30MHz

- a. The EUT was placed on the top of a rotating table 0.8 meters above the ground at a 3 meter chamber room. The table was rotated 360 degrees to determine the position of the highest radiation.
- b. The EUT was set 3 meters away from the interference-receiving antenna, which was mounted on the top of a variable-height antenna tower.
- c. Parallel, perpendicular, and ground-parallel orientations of the antenna are set to make the measurement.
- d. For each suspected emission, the EUT was arranged to its worst case and the rotatable table was turned from 0 degrees to 360 degrees to find the maximum reading.
- e. The test-receiver system was set to Quasi-Peak Detect Function and Specified Bandwidth with Maximum Hold Mode.

NOTE:

1. The resolution bandwidth and video bandwidth of test receiver/spectrum analyzer is 9kHz at frequency below 30MHz.

For Radiated emission above 30MHz

- a. The EUT was placed on the top of a rotating table 0.8 meters (for 30MHz ~ 1GHz) / 1.5 meters (for above 1GHz) above the ground at 3 meter chamber room for test. The table was rotated 360 degrees to determine the position of the highest radiation.
- b. The EUT was set 3 meters away from the interference-receiving antenna, which was mounted on the top of a variable-height antenna tower.
- c. The height of antenna is varied from one meter to four meters above the ground to determine the maximum value of the field strength. Both horizontal and vertical polarizations of the antenna are set to make the measurement.
- d. For each suspected emission, the EUT was arranged to its worst case and then the antenna was tuned to heights from 1 meter to 4 meters and the rotatable table was turned from 0 degrees to 360 degrees to find the maximum reading.
- e. The test-receiver system was set to quasi-peak detect function and specified bandwidth with maximum hold mode when the test frequency is below 1 GHz.
- f. The test-receiver system was set to peak and average detect function and specified bandwidth with maximum hold mode when the test frequency is above 1 GHz. If the peak reading value also meets average limit, measurement with the average detector is unnecessary.

Note:

1. The resolution bandwidth and video bandwidth of test receiver/spectrum analyzer is 120kHz for Quasi-peak detection (QP) at frequency below 1GHz.
2. The resolution bandwidth of test receiver/spectrum analyzer is 1 MHz and the video bandwidth is 3 MHz for Peak detection (PK) and Average detection at frequency above 1GHz. For fundamental and harmonic signal measurement, according to ANSI C63.10 section 7.5, the average value = peak value + duty factor. The duty factor refer to Chapter 3.3 of this report.
3. All modes of operation were investigated and the worst-case emissions are reported.

4.1.4 Deviation from Test Standard

No deviation.

4.1.5 Test Setup

For Radiated emission below 30MHz

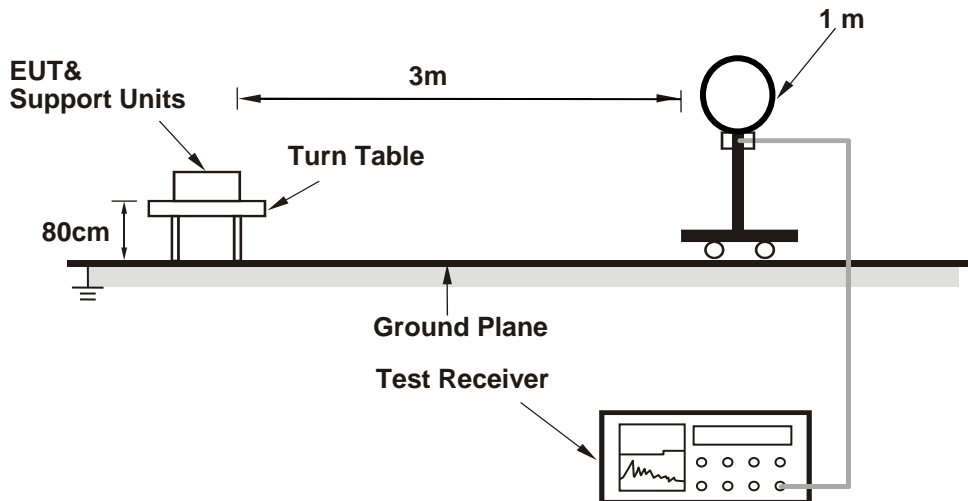

For Radiated emission 30MHz to 1GHz

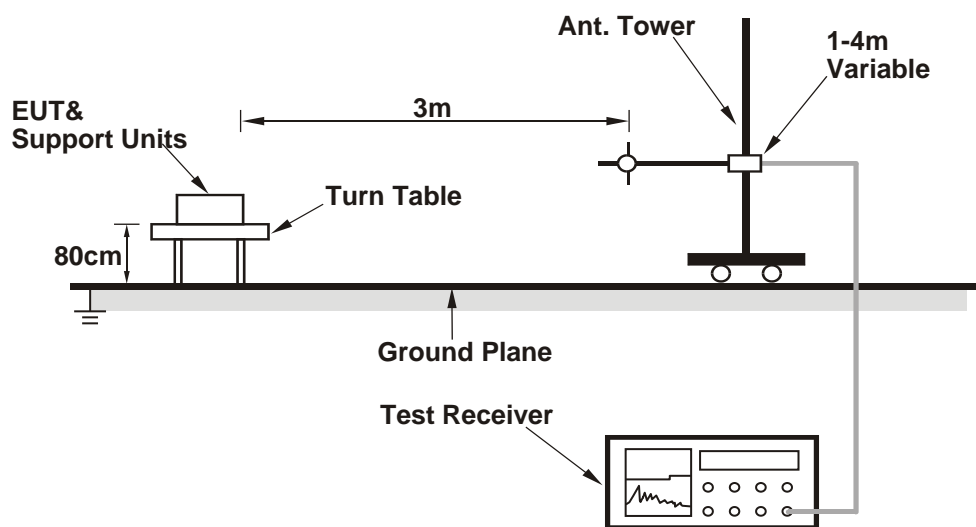

For Radiated emission above 1GHz

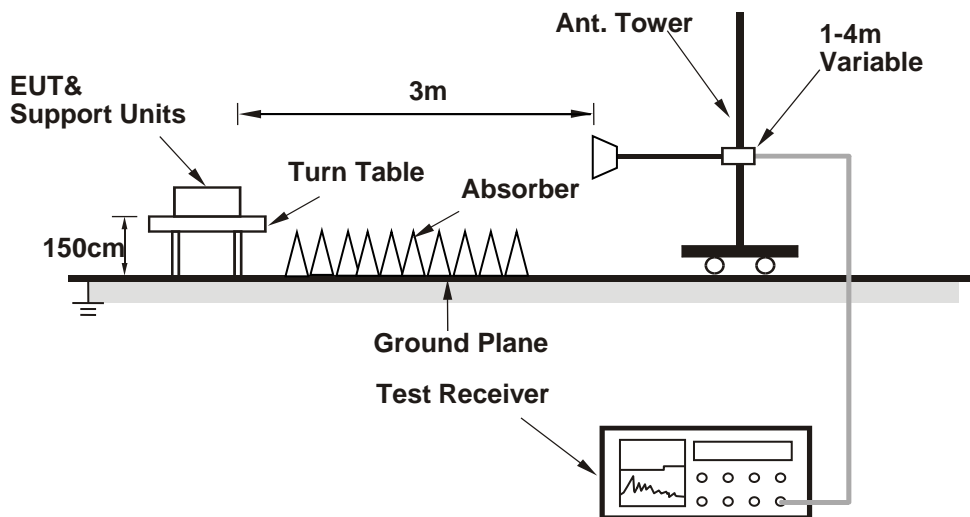

For the actual test configuration, please refer to the attached file (Test Setup Photo).

4.1.6 EUT Operating Conditions

- a. Connected the EUT and Dongle to Notebook PC.
- b. Set the EUT under transmission condition continuously at specific channel frequency.
- c. Set the EUT under charging condition.

4.1.7 Test Results

Mode A

ABOVE 1GHz DATA

| | | | |
|------------------------|--------------|--------------------------|---------------------------|
| RF Mode | TX BT_GFSK | Channel | CH 0 : 2402 MHz |
| Frequency Range | 1GHz ~ 25GHz | Detector Function | Peak (PK) Average (AV) |

| Antenna Polarity & Test Distance : Horizontal at 3 m | | | | | | | | |
|--|-----------------|-------------------------|----------------|-------------|--------------------|----------------------|------------------|--------------------------|
| No | Frequency (MHz) | Emission Level (dBuV/m) | Limit (dBuV/m) | Margin (dB) | Antenna Height (m) | Table Angle (Degree) | Raw Value (dBuV) | Correction Factor (dB/m) |
| 1 | 2390.00 | 50.45 PK | 74.00 | -23.55 | 1.68 H | 252 | 52.73 | -2.28 |
| 2 | 2390.00 | 39.52 AV | 54.00 | -14.48 | 1.68 H | 252 | 41.80 | -2.28 |
| 3 | 2400.00 | 57.39 PK | 74.00 | -16.61 | 1.68 H | 252 | 59.61 | -2.22 |
| 4 | 2400.00 | 37.99 AV | 54.00 | -16.01 | 1.68 H | 252 | 40.21 | -2.22 |
| 5 | *2402.00 | 99.29 PK | 114.00 | -14.71 | 1.68 H | 252 | 101.51 | -2.22 |
| 6 | *2402.00 | 79.89 AV | 94.00 | -14.11 | 1.68 H | 252 | 82.11 | -2.22 |
| 7 | 4804.00 | 48.52 PK | 74.00 | -25.48 | 1.45 H | 176 | 42.86 | 5.66 |
| 8 | 4804.00 | 29.12 AV | 54.00 | -24.88 | 1.45 H | 176 | 23.46 | 5.66 |

| Antenna Polarity & Test Distance : Vertical at 3 m | | | | | | | | |
|--|-----------------|-------------------------|----------------|-------------|--------------------|----------------------|------------------|--------------------------|
| No | Frequency (MHz) | Emission Level (dBuV/m) | Limit (dBuV/m) | Margin (dB) | Antenna Height (m) | Table Angle (Degree) | Raw Value (dBuV) | Correction Factor (dB/m) |
| 1 | 2390.00 | 49.59 PK | 74.00 | -24.41 | 2.11 V | 188 | 51.87 | -2.28 |
| 2 | 2390.00 | 38.80 AV | 54.00 | -15.20 | 2.11 V | 188 | 41.08 | -2.28 |
| 3 | 2400.00 | 54.93 PK | 74.00 | -19.07 | 2.11 V | 188 | 57.15 | -2.22 |
| 4 | 2400.00 | 35.53 AV | 54.00 | -18.47 | 2.11 V | 188 | 37.75 | -2.22 |
| 5 | *2402.00 | 96.83 PK | 114.00 | -17.17 | 2.11 V | 188 | 99.05 | -2.22 |
| 6 | *2402.00 | 77.43 AV | 94.00 | -16.57 | 2.11 V | 188 | 79.65 | -2.22 |
| 7 | 4804.00 | 47.00 PK | 74.00 | -27.00 | 1.98 V | 216 | 41.34 | 5.66 |
| 8 | 4804.00 | 27.60 AV | 54.00 | -26.40 | 1.98 V | 216 | 21.94 | 5.66 |

Remarks:

1. Emission Level(dBuV/m) = Raw Value(dBuV) + Correction Factor(dB/m)
2. Correction Factor(dB/m) = Antenna Factor(dB/m) + Cable Factor(dB) – Pre-Amplifier Factor(dB)
3. Margin value = Emission Level – Limit value
4. The other emission levels were very low against the limit.
5. " * ": Fundamental frequency.
6. The average value of fundamental and harmonic frequency is: Average value = Peak value + 20 log(Duty cycle) Where the duty factor is calculated from following formula:
 $20 \log(\text{Duty cycle}) = 20 \log(0.108 \text{ ms} / 1.008 \text{ ms}) = -19.4\text{dB}$
 Please refer to the plotted duty (see section 3.3)

| | | | |
|------------------------|--------------|--------------------------|---------------------------|
| RF Mode | TX BT_GFSK | Channel | CH 39 : 2441 MHz |
| Frequency Range | 1GHz ~ 25GHz | Detector Function | Peak (PK) Average (AV) |

Antenna Polarity & Test Distance : Horizontal at 3 m

| No | Frequency (MHz) | Emission Level (dBuV/m) | Limit (dBuV/m) | Margin (dB) | Antenna Height (m) | Table Angle (Degree) | Raw Value (dBuV) | Correction Factor (dB/m) |
|----|-----------------|-------------------------|----------------|-------------|--------------------|----------------------|------------------|--------------------------|
| 1 | *2441.00 | 99.75 PK | 114.00 | -14.25 | 1.82 H | 255 | 101.89 | -2.14 |
| 2 | *2441.00 | 80.35 AV | 94.00 | -13.65 | 1.82 H | 255 | 82.49 | -2.14 |
| 3 | 4882.00 | 48.32 PK | 74.00 | -25.68 | 1.78 H | 146 | 42.63 | 5.69 |
| 4 | 4882.00 | 28.92 AV | 54.00 | -25.08 | 1.78 H | 146 | 23.23 | 5.69 |

Antenna Polarity & Test Distance : Vertical at 3 m

| No | Frequency (MHz) | Emission Level (dBuV/m) | Limit (dBuV/m) | Margin (dB) | Antenna Height (m) | Table Angle (Degree) | Raw Value (dBuV) | Correction Factor (dB/m) |
|----|-----------------|-------------------------|----------------|-------------|--------------------|----------------------|------------------|--------------------------|
| 1 | *2441.00 | 97.64 PK | 114.00 | -16.36 | 2.05 V | 190 | 99.78 | -2.14 |
| 2 | *2441.00 | 78.24 AV | 94.00 | -15.76 | 2.05 V | 190 | 80.38 | -2.14 |
| 3 | 4882.00 | 47.66 PK | 74.00 | -26.34 | 2.39 V | 205 | 41.97 | 5.69 |
| 4 | 4882.00 | 28.26 AV | 54.00 | -25.74 | 2.39 V | 205 | 22.57 | 5.69 |

Remarks:

1. Emission Level(dBuV/m) = Raw Value(dBuV) + Correction Factor(dB/m)
2. Correction Factor(dB/m) = Antenna Factor(dB/m) + Cable Factor(dB) – Pre-Amplifier Factor(dB)
3. Margin value = Emission Level – Limit value
4. The other emission levels were very low against the limit.
5. " * ": Fundamental frequency.
6. The average value of fundamental and harmonic frequency is: Average value = Peak value + 20 log(Duty cycle) Where the duty factor is calculated from following formula:
 $20 \log(\text{Duty cycle}) = 20 \log(0.108 \text{ ms} / 1.008 \text{ ms}) = -19.4\text{dB}$
 Please refer to the plotted duty (see section 3.3)

| | | | |
|------------------------|--------------|--------------------------|---------------------------|
| RF Mode | TX BT_GFSK | Channel | CH 77 : 2479 MHz |
| Frequency Range | 1GHz ~ 25GHz | Detector Function | Peak (PK) Average (AV) |

Antenna Polarity & Test Distance : Horizontal at 3 m

| No | Frequency (MHz) | Emission Level (dBuV/m) | Limit (dBuV/m) | Margin (dB) | Antenna Height (m) | Table Angle (Degree) | Raw Value (dBuV) | Correction Factor (dB/m) |
|----|-----------------|-------------------------|----------------|-------------|--------------------|----------------------|------------------|--------------------------|
| 1 | *2479.00 | 99.73 PK | 114.00 | -14.27 | 1.78 H | 295 | 101.70 | -1.97 |
| 2 | *2479.00 | 80.33 AV | 94.00 | -13.67 | 1.78 H | 295 | 82.30 | -1.97 |
| 3 | 2483.50 | 52.31 PK | 74.00 | -21.69 | 1.78 H | 295 | 54.25 | -1.94 |
| 4 | 2483.50 | 40.02 AV | 54.00 | -13.98 | 1.78 H | 295 | 41.96 | -1.94 |
| 5 | 4958.00 | 48.73 PK | 74.00 | -25.27 | 1.92 H | 206 | 42.88 | 5.85 |
| 6 | 4958.00 | 29.33 AV | 54.00 | -24.67 | 1.92 H | 206 | 23.48 | 5.85 |

Antenna Polarity & Test Distance : Vertical at 3 m

| No | Frequency (MHz) | Emission Level (dBuV/m) | Limit (dBuV/m) | Margin (dB) | Antenna Height (m) | Table Angle (Degree) | Raw Value (dBuV) | Correction Factor (dB/m) |
|----|-----------------|-------------------------|----------------|-------------|--------------------|----------------------|------------------|--------------------------|
| 1 | *2479.00 | 97.66 PK | 114.00 | -16.34 | 1.99 V | 185 | 99.63 | -1.97 |
| 2 | *2479.00 | 78.26 AV | 94.00 | -15.74 | 1.99 V | 185 | 80.23 | -1.97 |
| 3 | 2483.50 | 51.68 PK | 74.00 | -22.32 | 1.99 V | 185 | 53.62 | -1.94 |
| 4 | 2483.50 | 38.75 AV | 54.00 | -15.25 | 1.99 V | 185 | 40.69 | -1.94 |
| 5 | 4958.00 | 47.13 PK | 74.00 | -26.87 | 2.13 V | 254 | 41.28 | 5.85 |
| 6 | 4958.00 | 27.73 AV | 54.00 | -26.27 | 2.13 V | 254 | 21.88 | 5.85 |

Remarks:

1. Emission Level(dBuV/m) = Raw Value(dBuV) + Correction Factor(dB/m)
2. Correction Factor(dB/m) = Antenna Factor(dB/m) + Cable Factor(dB) – Pre-Amplifier Factor(dB)
3. Margin value = Emission Level – Limit value
4. The other emission levels were very low against the limit.
5. " * " : Fundamental frequency.
6. The average value of fundamental and harmonic frequency is: Average value = Peak value + 20 log(Duty cycle) Where the duty factor is calculated from following formula:
 $20 \log(\text{Duty cycle}) = 20 \log(0.108 \text{ ms} / 1.008 \text{ ms}) = -19.4\text{dB}$
 Please refer to the plotted duty (see section 3.3)

BELOW 1GHz WORST-CASE DATA

| | | | |
|------------------------|-------------|--------------------------|------------------|
| RF Mode | TX GFSK | Channel | CH 39 : 2441 MHz |
| Frequency Range | 9kHz ~ 1GHz | Detector Function | Quasi-Peak (QP) |

| Antenna Polarity & Test Distance : Horizontal at 3 m | | | | | | | | |
|--|-----------------|-------------------------|----------------|-------------|--------------------|----------------------|------------------|--------------------------|
| No | Frequency (MHz) | Emission Level (dBuV/m) | Limit (dBuV/m) | Margin (dB) | Antenna Height (m) | Table Angle (Degree) | Raw Value (dBuV) | Correction Factor (dB/m) |
| 1 | 66.86 | 22.32 QP | 40.00 | -17.68 | 3.00 H | 218 | 35.69 | -13.37 |
| 2 | 145.43 | 18.59 QP | 43.50 | -24.91 | 2.71 H | 189 | 30.21 | -11.62 |
| 3 | 321.97 | 24.55 QP | 46.00 | -21.45 | 2.45 H | 163 | 33.20 | -8.65 |
| 4 | 409.27 | 19.78 QP | 46.00 | -26.22 | 3.62 H | 280 | 26.86 | -7.08 |
| 5 | 530.52 | 23.77 QP | 46.00 | -22.23 | 2.06 H | 126 | 28.53 | -4.76 |
| 6 | 741.01 | 28.21 QP | 46.00 | -17.79 | 1.63 H | 82 | 28.27 | -0.06 |

Remarks:

1. Emission Level(dBuV/m) = Raw Value(dBuV) + Correction Factor(dB/m)
2. Correction Factor(dB/m) = Antenna Factor(dB/m) + Cable Factor(dB) – Pre-Amplifier Factor(dB)
3. Margin value = Emission Level – Limit value
4. The other emission levels were very low against the limit of frequency range 30MHz~1000MHz.
5. The emission levels were very low against the limit of frequency range 9kHz~30MHz: the amplitude of spurious emissions attenuated more than 20 dB below the permissible value to be report.

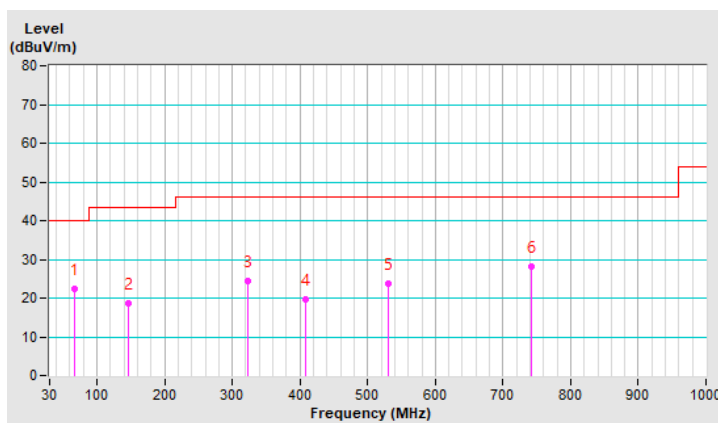

| | | | |
|------------------------|-------------|--------------------------|------------------|
| RF Mode | TX GFSK | Channel | CH 39 : 2441 MHz |
| Frequency Range | 9kHz ~ 1GHz | Detector Function | Quasi-Peak (QP) |

| Antenna Polarity & Test Distance : Vertical at 3 m | | | | | | | | |
|--|-----------------|-------------------------|----------------|-------------|--------------------|----------------------|------------------|--------------------------|
| No | Frequency (MHz) | Emission Level (dBuV/m) | Limit (dBuV/m) | Margin (dB) | Antenna Height (m) | Table Angle (Degree) | Raw Value (dBuV) | Correction Factor (dB/m) |
| 1 | 51.34 | 26.73 QP | 40.00 | -13.27 | 1.91 V | 171 | 38.78 | -12.05 |
| 2 | 87.23 | 19.57 QP | 40.00 | -20.43 | 2.48 V | 227 | 37.09 | -17.52 |
| 3 | 283.17 | 17.97 QP | 46.00 | -28.03 | 1.10 V | 92 | 27.76 | -9.79 |
| 4 | 390.84 | 19.99 QP | 46.00 | -26.01 | 2.90 V | 269 | 27.46 | -7.47 |
| 5 | 517.91 | 23.73 QP | 46.00 | -22.27 | 3.36 V | 314 | 28.49 | -4.76 |
| 6 | 671.17 | 26.35 QP | 46.00 | -19.65 | 3.73 V | 352 | 28.10 | -1.75 |

Remarks:

1. Emission Level(dBuV/m) = Raw Value(dBuV) + Correction Factor(dB/m)
2. Correction Factor(dB/m) = Antenna Factor(dB/m) + Cable Factor(dB) – Pre-Amplifier Factor(dB)
3. Margin value = Emission Level – Limit value
4. The other emission levels were very low against the limit of frequency range 30MHz~1000MHz.
5. The emission levels were very low against the limit of frequency range 9kHz~30MHz: the amplitude of spurious emissions attenuated more than 20 dB below the permissible value to be report.

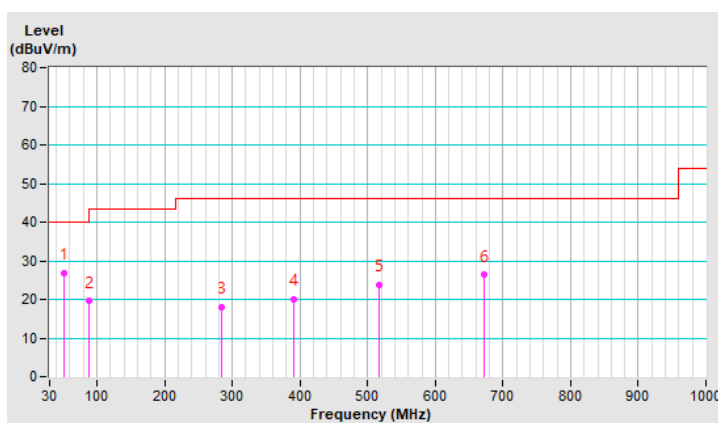

Mode C

ABOVE 1GHz DATA

| | | | |
|------------------------|--------------|--------------------------|--------------------------------------|
| RF Mode | TX BT_GFSK | Channel | CH 0 : 2402 MHz, CH 39 : 2441 MHz |
| Frequency Range | 1GHz ~ 25GHz | Detector Function | Peak (PK) Average (AV) |

| Antenna Polarity & Test Distance : Horizontal at 3 m | | | | | | | | |
|--|-----------------|-------------------------|----------------|---------------|--------------------|----------------------|------------------|--------------------------|
| No | Frequency (MHz) | Emission Level (dBuV/m) | Limit (dBuV/m) | Margin (dB) | Antenna Height (m) | Table Angle (Degree) | Raw Value (dBuV) | Correction Factor (dB/m) |
| 1 | 2390.00 | 55.69 PK | 74.00 | -18.31 | 1.69 H | 43 | 57.97 | -2.28 |
| 2 | 2390.00 | 40.10 AV | 54.00 | -13.90 | 1.69 H | 43 | 42.38 | -2.28 |
| 3 | 2400.00 | 58.13 PK | 74.00 | -15.87 | 1.69 H | 43 | 60.35 | -2.22 |
| 4 | 2400.00 | 38.73 AV | 54.00 | -15.27 | 1.69 H | 43 | 40.95 | -2.22 |
| 5 | *2402.00 | 98.78 PK | 114.00 | -15.22 | 1.61 H | 245 | 101.00 | -2.22 |
| 6 | *2402.00 | 79.38 AV | 94.00 | -14.62 | 1.61 H | 245 | 81.60 | -2.22 |
| 7 | *2441.00 | 102.08 PK | 114.00 | -11.92 | 1.42 H | 149 | 104.22 | -2.14 |
| 8 | *2441.00 | 82.58 AV | 94.00 | -11.42 | 1.42 H | 149 | 84.72 | -2.14 |
| 9 | 4804.00 | 47.83 PK | 74.00 | -26.17 | 1.63 H | 265 | 42.17 | 5.66 |
| 10 | 4804.00 | 28.43 AV | 54.00 | -25.57 | 1.63 H | 265 | 22.77 | 5.66 |
| 11 | 4882.00 | 48.93 PK | 74.00 | -25.07 | 2.41 H | 152 | 43.24 | 5.69 |
| 12 | 4882.00 | 29.43 AV | 54.00 | -24.57 | 2.41 H | 152 | 23.74 | 5.69 |

| Antenna Polarity & Test Distance : Vertical at 3 m | | | | | | | | |
|--|-----------------|-------------------------|----------------|-------------|--------------------|----------------------|------------------|--------------------------|
| No | Frequency (MHz) | Emission Level (dBuV/m) | Limit (dBuV/m) | Margin (dB) | Antenna Height (m) | Table Angle (Degree) | Raw Value (dBuV) | Correction Factor (dB/m) |
| 1 | 2390.00 | 52.96 PK | 74.00 | -21.04 | 1.94 V | 230 | 55.24 | -2.28 |
| 2 | 2390.00 | 38.03 AV | 54.00 | -15.97 | 1.94 V | 230 | 40.31 | -2.28 |
| 3 | 2400.00 | 56.19 PK | 74.00 | -17.81 | 1.94 V | 230 | 58.41 | -2.22 |
| 4 | 2400.00 | 36.79 AV | 54.00 | -17.21 | 1.94 V | 230 | 39.01 | -2.22 |
| 5 | *2402.00 | 96.49 PK | 114.00 | -17.51 | 2.07 V | 192 | 98.71 | -2.22 |
| 6 | *2402.00 | 77.09 AV | 94.00 | -16.91 | 2.07 V | 192 | 79.31 | -2.22 |
| 7 | *2441.00 | 99.13 PK | 114.00 | -14.87 | 1.35 V | 157 | 101.27 | -2.14 |
| 8 | *2441.00 | 79.63 AV | 94.00 | -14.37 | 1.35 V | 157 | 81.77 | -2.14 |
| 9 | 4804.00 | 47.21 PK | 74.00 | -26.79 | 1.74 V | 152 | 41.55 | 5.66 |
| 10 | 4804.00 | 27.81 AV | 54.00 | -26.19 | 1.74 V | 152 | 22.15 | 5.66 |
| 11 | 4882.00 | 47.82 PK | 74.00 | -26.18 | 2.05 V | 163 | 42.13 | 5.69 |
| 12 | 4882.00 | 28.32 AV | 54.00 | -25.68 | 2.05 V | 163 | 22.63 | 5.69 |

Remarks:

1. Emission Level(dBuV/m) = Raw Value(dBuV) + Correction Factor(dB/m)
2. Correction Factor(dB/m) = Antenna Factor(dB/m) + Cable Factor(dB) – Pre-Amplifier Factor(dB)
3. Margin value = Emission Level – Limit value
4. The other emission levels were very low against the limit.
5. " * ": Fundamental frequency.
6. The average value of fundamental and harmonic frequency is: Average value = Peak value + 20 log(Duty cycle) Where the duty factor is calculated from following formula:
Mouse: 20 log(Duty cycle) =20 log(0.108 ms / 1.008 ms) = -19.4dB
Dongle: 20 log(Duty cycle) =20 log(0.105 ms / 0.987 ms) = -19.5dB
Please refer to the plotted duty (see section 3.3)

4.2 Conducted Emission Measurement

4.2.1 Limits of Conducted Emission Measurement

| Frequency (MHz) | Conducted Limit (dBuV) | |
|-----------------|------------------------|---------|
| | Quasi-peak | Average |
| 0.15 - 0.5 | 66 - 56 | 56 - 46 |
| 0.50 - 5.0 | 56 | 46 |
| 5.0 - 30.0 | 60 | 50 |

Note: 1. The lower limit shall apply at the transition frequencies.

2. The limit decreases in line with the logarithm of the frequency in the range of 0.15 to 0.50MHz.

4.2.2 Test Instruments

| Description & Manufacturer | Model no. | Serial No. | Calibrated Date | Calibrated Until |
|--|---------------|--------------|-----------------|------------------|
| Test Receiver ESR3 R&S | ESR3 | 102412 | 2021/1/29 | 2022/1/28 |
| LISN SCHWARZBECK | NSLK 8128 | 8128-244 | 2020/11/19 | 2021/11/18 |
| LISN SCHWARZBECK | NNLK8129 | 8129229 | 2021/5/20 | 2022/5/19 |
| DC LISN SCHWARZBECK | NNLK 8121 | 8121-808 | 2021/4/18 | 2022/4/17 |
| LISN SCHWARZBECK | NNLK 8121 | 8121-731 | 2021/4/28 | 2022/4/27 |
| LISN R&S | ENV216 | 101196 | 2021/4/26 | 2022/4/25 |
| LISN R&S | ESH3-Z5 | 100220 | 2020/12/1 | 2021/11/30 |
| LISN R&S | ESH3-Z6 | 844950/018 | 2021/7/25 | 2022/7/24 |
| DC LISN R&S | ESH3-Z6 | 100219 | 2021/7/25 | 2022/7/24 |
| High Voltage Probe Schwarzbeck | TK9420 | 00982 | 2021/1/8 | 2022/1/7 |
| RF Coaxial Cable Commate | 5D-FB | Cable-CO5-01 | 2021/1/29 | 2022/1/28 |
| Attenuator STI | STI02-2200-10 | NO.4 | 2021/9/3 | 2022/9/2 |
| 50 Ohms Terminator LYNICS | 0900510 | E1-01-305 | 2021/2/17 | 2022/2/16 |
| Isolation Transformer Erika Fiedler | D-65396 | 017 | 2020/9/14 | 2021/9/13 |
| Software BVADT | Cond_V7.3.7.4 | NA | NA | NA |

Note: 1. The calibration interval of the above test instruments is 12 months and the calibrations are traceable to NML/ROC and NIST/USA.

2. The test was performed in Linkou Conduction05

3. The VCCI Site Registration No. C-11093.

4. Tested Date: 2021/9/9

4.2.3 Test Procedures

- The EUT was placed 0.4 meters from the conducting wall of the shielded room with EUT being connected to the power mains through a line impedance stabilization network (LISN). Other support units were connected to the power mains through another LISN. The two LISNs provide 50 ohm/ 50uH of coupling impedance for the measuring instrument.
- Both lines of the power mains connected to the EUT were checked for maximum conducted interference.
- The frequency range from 150kHz to 30MHz was searched. Emission levels under (Limit - 20dB) was not recorded.

NOTE: The resolution bandwidth and video bandwidth of test receiver is 9kHz for quasi-peak detection (QP) and average detection (AV) at frequency 0.15MHz-30MHz.

4.2.4 Deviation From Test Standard

No deviation.

4.2.5 Test Setup

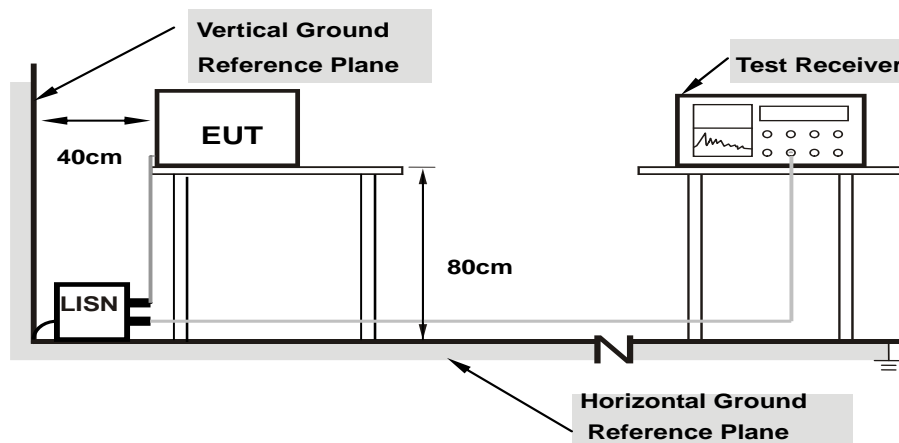

Note: 1.Support units were connected to second LISN.

For the actual test configuration, please refer to the attached file (Test Setup Photo).

4.2.6 EUT Operating Condition

- Connected the EUT to Notebook PC or Adapter.
- Set the EUT under transmission condition continuously at specific channel frequency.
- Set the EUT under charging condition.

4.2.7 Test Results

Mode A

| | | | |
|-----------------|----------------|-------------------|--------------------------------|
| Frequency Range | 150kHz ~ 30MHz | Detector Function | Quasi-Peak (QP) / Average (AV) |
|-----------------|----------------|-------------------|--------------------------------|

| Phase Of Power : Line (L) | | | | | | | | | | |
|---------------------------|-----------------|------------------------|----------------------|--------------|-----------------------|--------------|--------------|--------------|---------------|--------------|
| No | Frequency (MHz) | Correction Factor (dB) | Reading Value (dBuV) | | Emission Level (dBuV) | | Limit (dBuV) | | Margin (dB) | |
| | | | Q.P. | AV. | Q.P. | AV. | Q.P. | AV. | Q.P. | AV. |
| 1 | 0.15000 | 9.89 | 40.08 | 26.64 | 49.97 | 36.53 | 66.00 | 56.00 | -16.03 | -19.47 |
| 2 | 0.36160 | 9.91 | 23.90 | 15.83 | 33.81 | 25.74 | 58.69 | 48.69 | -24.88 | -22.95 |
| 3 | 0.52290 | 9.92 | 32.30 | 26.24 | 42.22 | 36.16 | 56.00 | 46.00 | -13.78 | -9.84 |
| 4 | 0.94000 | 9.97 | 19.97 | 14.73 | 29.94 | 24.70 | 56.00 | 46.00 | -26.06 | -21.30 |
| 5 | 3.54000 | 10.11 | 19.85 | 9.89 | 29.96 | 20.00 | 56.00 | 46.00 | -26.04 | -26.00 |
| 6 | 9.33200 | 10.35 | 10.92 | 6.62 | 21.27 | 16.97 | 60.00 | 50.00 | -38.73 | -33.03 |

Remarks:

1. Q.P. and AV. are abbreviations of quasi-peak and average individually.
2. The emission levels of other frequencies were very low against the limit.
3. Margin value = Emission level – Limit value
4. Correction factor = Insertion loss + Cable loss
5. Emission Level = Correction Factor + Reading Value

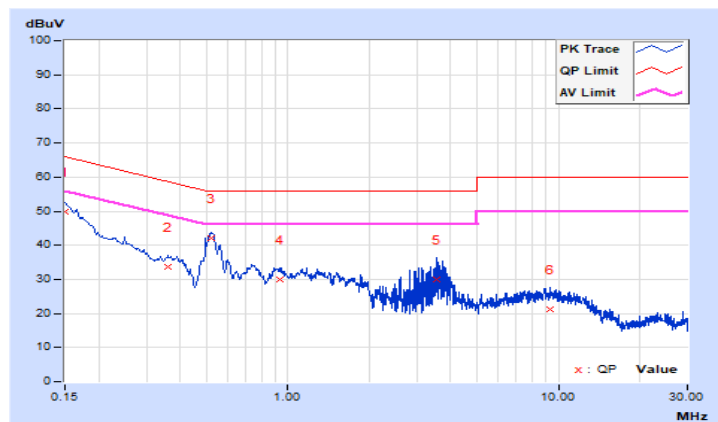

| | | | |
|-----------------|----------------|-------------------|--------------------------------|
| Frequency Range | 150kHz ~ 30MHz | Detector Function | Quasi-Peak (QP) / Average (AV) |
|-----------------|----------------|-------------------|--------------------------------|

| Phase Of Power : Neutral (N) | | | | | | | | | | |
|------------------------------|-----------------|------------------------|----------------------|-------|-----------------------|-------|--------------|-------|-------------|--------|
| No | Frequency (MHz) | Correction Factor (dB) | Reading Value (dBuV) | | Emission Level (dBuV) | | Limit (dBuV) | | Margin (dB) | |
| | | | Q.P. | AV. | Q.P. | AV. | Q.P. | AV. | Q.P. | AV. |
| 1 | 0.15400 | 9.91 | 37.22 | 17.02 | 47.13 | 26.93 | 65.78 | 55.78 | -18.65 | -28.85 |
| 2 | 0.54397 | 9.94 | 30.76 | 23.64 | 40.70 | 33.58 | 56.00 | 46.00 | -15.30 | -12.42 |
| 3 | 0.82400 | 9.97 | 16.95 | 11.25 | 26.92 | 21.22 | 56.00 | 46.00 | -29.08 | -24.78 |
| 4 | 1.26000 | 10.01 | 15.09 | 10.63 | 25.10 | 20.64 | 56.00 | 46.00 | -30.90 | -25.36 |
| 5 | 3.82800 | 10.14 | 21.49 | 9.82 | 31.63 | 19.96 | 56.00 | 46.00 | -24.37 | -26.04 |
| 6 | 11.42800 | 10.43 | 12.66 | 8.40 | 23.09 | 18.83 | 60.00 | 50.00 | -36.91 | -31.17 |

Remarks:

1. Q.P. and AV. are abbreviations of quasi-peak and average individually.
2. The emission levels of other frequencies were very low against the limit.
3. Margin value = Emission level – Limit value
4. Correction factor = Insertion loss + Cable loss
5. Emission Level = Correction Factor + Reading Value

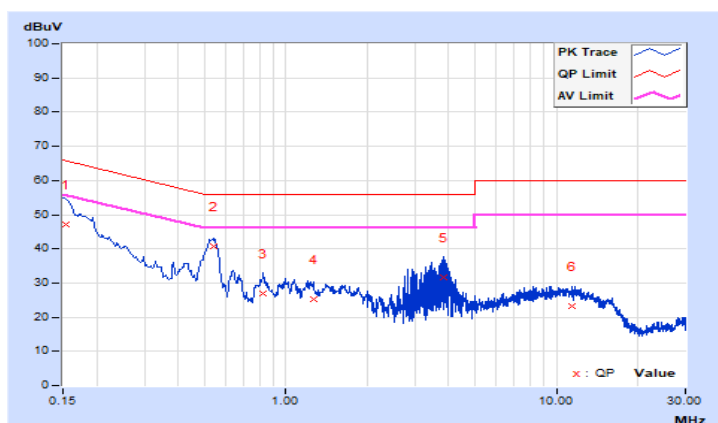

Mode B

| | | | |
|-----------------|----------------|-------------------|--------------------------------|
| Frequency Range | 150kHz ~ 30MHz | Detector Function | Quasi-Peak (QP) / Average (AV) |
|-----------------|----------------|-------------------|--------------------------------|

| Phase Of Power : Line (L) | | | | | | | | | | |
|---------------------------|-----------------|------------------------|----------------------|-------|-----------------------|-------|--------------|-------|-------------|--------|
| No | Frequency (MHz) | Correction Factor (dB) | Reading Value (dBuV) | | Emission Level (dBuV) | | Limit (dBuV) | | Margin (dB) | |
| | | | Q.P. | AV. | Q.P. | AV. | Q.P. | AV. | Q.P. | AV. |
| 1 | 0.16200 | 9.89 | 18.55 | 3.76 | 28.44 | 13.65 | 65.36 | 55.36 | -36.92 | -41.71 |
| 2 | 0.23800 | 9.89 | 13.86 | 2.80 | 23.75 | 12.69 | 62.17 | 52.17 | -38.42 | -39.48 |
| 3 | 0.78800 | 9.96 | 19.71 | 13.19 | 29.67 | 23.15 | 56.00 | 46.00 | -26.33 | -22.85 |
| 4 | 1.39600 | 10.00 | 10.74 | 3.78 | 20.74 | 13.78 | 56.00 | 46.00 | -35.26 | -32.22 |
| 5 | 3.86800 | 10.13 | 10.97 | 5.35 | 21.10 | 15.48 | 56.00 | 46.00 | -34.90 | -30.52 |
| 6 | 9.13600 | 10.35 | 9.34 | 3.98 | 19.69 | 14.33 | 60.00 | 50.00 | -40.31 | -35.67 |

Remarks:

1. Q.P. and AV. are abbreviations of quasi-peak and average individually.
2. The emission levels of other frequencies were very low against the limit.
3. Margin value = Emission level – Limit value
4. Correction factor = Insertion loss + Cable loss
5. Emission Level = Correction Factor + Reading Value

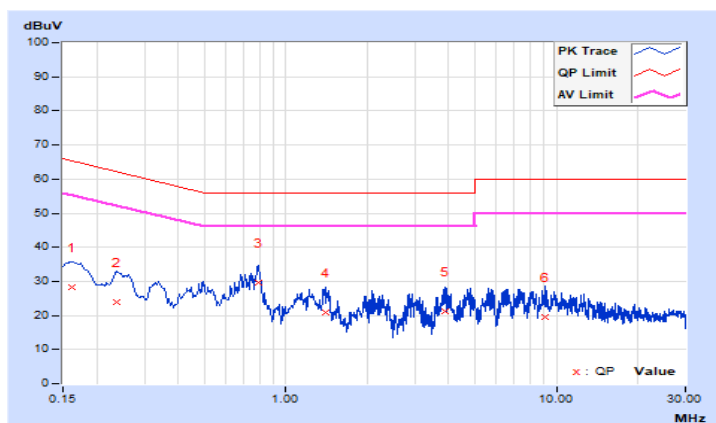

| | | | |
|-----------------|----------------|-------------------|--------------------------------|
| Frequency Range | 150kHz ~ 30MHz | Detector Function | Quasi-Peak (QP) / Average (AV) |
|-----------------|----------------|-------------------|--------------------------------|

| Phase Of Power : Neutral (N) | | | | | | | | | | |
|------------------------------|-----------------|------------------------|----------------------|------|-----------------------|-------|--------------|-------|-------------|--------|
| No | Frequency (MHz) | Correction Factor (dB) | Reading Value (dBuV) | | Emission Level (dBuV) | | Limit (dBuV) | | Margin (dB) | |
| | | | Q.P. | AV. | Q.P. | AV. | Q.P. | AV. | Q.P. | AV. |
| 1 | 0.16190 | 9.91 | 18.55 | 4.41 | 28.46 | 14.32 | 65.37 | 55.37 | -36.91 | -41.05 |
| 2 | 0.32600 | 9.92 | 10.56 | 0.34 | 20.48 | 10.26 | 59.55 | 49.55 | -39.07 | -39.29 |
| 3 | 0.78800 | 9.97 | 16.96 | 8.21 | 26.93 | 18.18 | 56.00 | 46.00 | -29.07 | -27.82 |
| 4 | 1.24400 | 10.00 | 5.99 | 1.59 | 15.99 | 11.59 | 56.00 | 46.00 | -40.01 | -34.41 |
| 5 | 3.89600 | 10.14 | 9.49 | 4.72 | 19.63 | 14.86 | 56.00 | 46.00 | -36.37 | -31.14 |
| 6 | 12.26400 | 10.46 | 9.30 | 4.43 | 19.76 | 14.89 | 60.00 | 50.00 | -40.24 | -35.11 |

Remarks:

1. Q.P. and AV. are abbreviations of quasi-peak and average individually.
2. The emission levels of other frequencies were very low against the limit.
3. Margin value = Emission level – Limit value
4. Correction factor = Insertion loss + Cable loss
5. Emission Level = Correction Factor + Reading Value

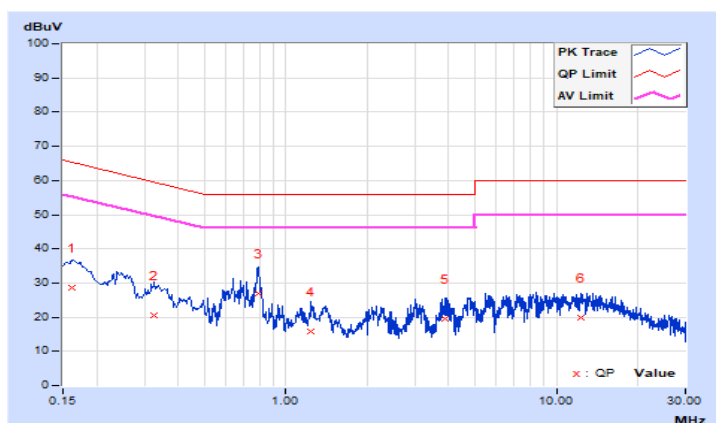

4.3 Channel Bandwidth

4.3.1 Test Setup

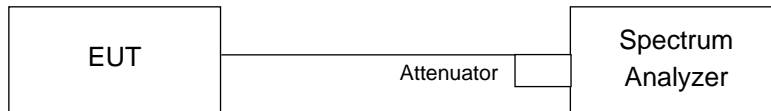

4.3.2 Test Instruments

| Description & Manufacturer | Model no. | Serial No. | Calibrated Date | Calibrated Until |
|----------------------------|-----------|------------|-----------------|------------------|
| Spectrum Analyzer R&S | FSV40 | 101544 | 2021/5/24 | 2022/5/23 |

- NOTE:**
1. The calibration interval of the above test instruments is 12/24 months. And the calibrations are traceable to NML/ROC and NIST/USA.
 2. The test was performed in LK - Oven
 2. Tested Date: 2021/9/2

4.3.3 Test Procedure

- a. Check the calibration of the measuring instrument using either an internal calibrator or a known signal from an external generator.
- b. Turn on the EUT and connect it to measurement instrument. Then set it to any one convenient frequency within its operating range. Set a reference level on the measuring instrument equal to the highest peak value.
- c. Measure the frequency difference of two frequencies that were attenuated 20dB from the reference level. Record the frequency difference as the emission bandwidth.
- d. Repeat above procedures until all frequencies measured were complete.

4.3.4 Deviation from Test Standard

No deviation.

4.3.5 EUT Operating Condition

The software provided by client enabled the EUT to transmit and receive data at lowest, middle and highest channel frequencies individually.

4.3.6 Test Results

Mode A

| Channel | Frequency (MHz) | 20dB Bandwidth (MHz) |
|---------|-----------------|----------------------|
| 0 | 2402 | 2.10 |
| 39 | 2441 | 2.12 |
| 77 | 2479 | 2.11 |

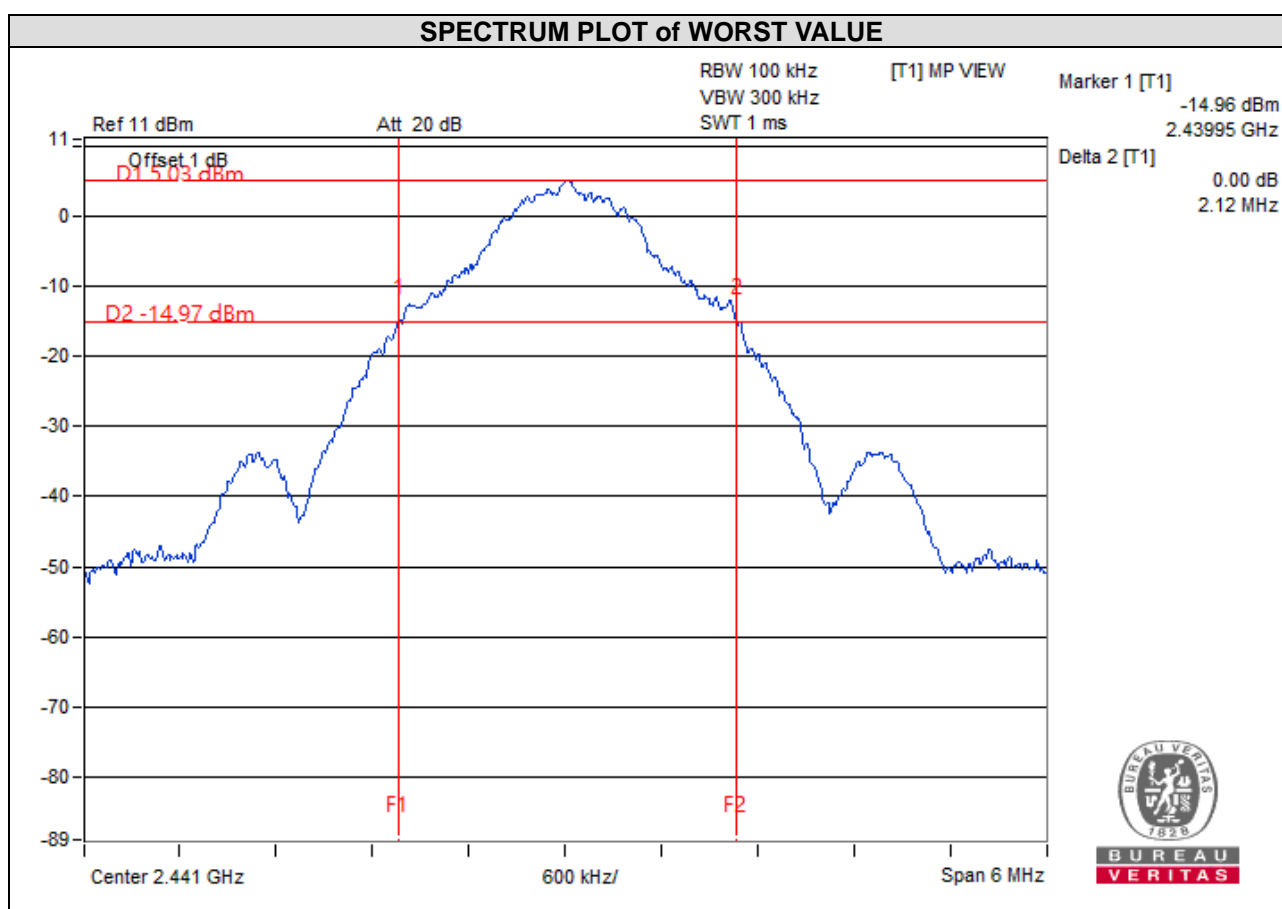

5 Pictures of Test Arrangements

Please refer to the attached file (Test Setup Photo).

Appendix – Information of the Testing Laboratories

We, Bureau Veritas Consumer Products Services (H.K.) Ltd., Taoyuan Branch, were founded in 1988 to provide our best service in EMC, Radio, Telecom and Safety consultation. Our laboratories are FCC recognized accredited test firms and accredited according to ISO/IEC 17025.

If you have any comments, please feel free to contact us at the following:

Lin Kou EMC/RF Lab

Tel: 886-2-26052180

Fax: 886-2-26051924

Hsin Chu EMC/RF/Telecom Lab

Tel: 886-3-6668565

Fax: 886-3-6668323

Hwa Ya EMC/RF/Safety Lab

Tel: 886-3-3183232

Fax: 886-3-3270892

Email: service.adt@tw.bureauveritas.com

Web Site: www.bureauveritas-adt.com

The address and road map of all our labs can be found in our web site also.

--- END ---