

FCC TEST REPORT

REPORT NO.: RF940802A11

MODEL NO.: VGP-BMS30

RECEIVED: Aug. 4, 2005

TESTED: Aug. 8 ~ 18, 2005

ISSUED: Aug. 22, 2005

APPLICANT: PRIMAX ELECTRONICS LTD.

ADDRESS: No. 669, Ruey Kuang Road, Neihu, Taipei, Taiwan.
R.O.C.

ISSUED BY: ADVANCE DATA TECHNOLOGY CORPORATION

LAB LOCATION: NO. 47, 14TH LING, CHIA PAU TSUEN, LIN KOU
HSIANG 244, TAIPEI HSIEN, TAIWAN, R.O.C.

This test report consists of 46 pages in total. It may be duplicated completely for legal use with the approval of the applicant. It should not be reproduced except in full, without the written approval of our laboratory. The client should not use it to claim product endorsement by CNLA, A2LA or any government agencies. The test results in the report only apply to the tested sample.



NO. 2177-01



0528
ILAC MRA



TABLE OF CONTENTS

1.	CERTIFICATION	4
2.	SUMMARY OF TEST RESULTS	5
2.1	MEASUREMENT UNCERTAINTY	6
3.	GENERAL INFORMATION.....	7
3.1	GENERAL DESCRIPTION OF EUT.....	7
3.2	DESCRIPTION OF TEST MODES.....	8
3.2.1	CONFIGURATION OF SYSTEM UNDER TEST	9
3.2.2	TEST MODE APPLICABILITY AND TESTED CHANNEL DETAIL	10
3.3.3	GENERAL DESCRIPTION OF APPLIED STANDARDS	12
3.3.4	DESCRIPTION OF SUPPORT UNITS.....	12
4.	TEST TYPES AND RESULTS.....	13
4.1	CONDUCTED EMISSION MEASUREMENT	13
4.2	RADIATED EMISSION MEASUREMENT	13
4.2.1	LIMITS OF RADIATED EMISSION MEASUREMENT.....	13
4.2.2	TEST INSTRUMENTS	14
4.2.3	TEST PROCEDURES.....	15
4.2.4	DEVIATION FROM TEST STANDARD	15
4.2.5	TEST SETUP	16
4.2.6	EUT OPERATING CONDITIONS.....	16
4.2.7	TEST RESULTS.....	17
4.3	NUMBER OF HOPPING FREQUENCY USED	21
4.3.1	LIMIT OF HOPPING FREQUENCY USED	21
4.3.2	TEST INSTRUMENTS	21
4.3.3	TEST PROCEDURES.....	21
4.3.4	DEVIATION FROM TEST STANDARD	22
4.3.5	TEST SETUP	22
4.3.6	TEST RESULTS.....	22
4.4	DWELL TIME ON EACH CHANNEL	24
4.4.1	LIMIT OF DWELL TIME USED	24
4.4.2	TEST INSTRUMENTS	24
4.4.3	TEST PROCEDURES.....	24
4.4.4	DEVIATION FROM TEST STANDARD	24
4.4.5	TEST SETUP	25
4.4.6	TEST RESULTS.....	25
4.5	CHANNEL BANDWIDTH.....	28
4.5.1	LIMITS OF CHANNEL BANDWIDTH.....	28
4.5.2	TEST INSTRUMENTS	28
4.5.3	TEST PROCEDURE	28
4.5.4	DEVIATION FROM TEST STANDARD	29
4.5.5	TEST SETUP	29
4.5.6	EUT OPERATING CONDITION	29
4.5.7	TEST RESULTS.....	29
4.6	HOPPING CHANNEL SEPARATION	32
4.6.1	LIMIT OF HOPPING CHANNEL SEPARATION	32



- 4.6.2 TEST INSTRUMENTS 32
- 4.6.3 TEST PROCEDURES..... 32
- 4.6.4 DEVIATION FROM TEST STANDARD 33
- 4.6.5 TEST SETUP 33
- 4.6.6 TEST RESULTS..... 33
- 4.7 MAXIMUM PEAK OUTPUT POWER 36
- 4.7.1 LIMITS OF MAXIMUM PEAK OUTPUT POWER MEASUREMENT 36
- 4.7.2 TEST INSTRUMENTS 36
- 4.7.3 TEST PROCEDURES..... 36
- 4.7.4 DEVIATION FROM TEST STANDARD 36
- 4.7.5 TEST SETUP 37
- 4.7.6 EUT OPERATING CONDITION 37
- 4.7.7 TEST RESULTS..... 37
- 4.8 BAND EDGES MEASUREMENT 40
- 4.8.1 LIMITS OF BAND EDGES MEASUREMENT..... 40
- 4.8.2 TEST INSTRUMENTS 40
- 4.8.3 TEST PROCEDURE 40
- 4.8.4 DEVIATION FROM TEST STANDARD 40
- 4.8.5 EUT OPERATING CONDITION 40
- 4.8.6 TEST RESULTS..... 41
- 4.9 ANTENNA REQUIREMENT 44
- 4.9.1 STANDARD APPLICABLE 44
- 4.9.2 ANTENNA CONNECTED CONSTRUCTION 44
- 5. PHOTOGRAPHS OF THE TEST CONFIGURATION..... 45
- 6. INFORMATION ON THE TESTING LABORATORIES 46



1. CERTIFICATION

PRODUCT : BLUETOOTH WIRELESS MOUSE
BRAND NAME : SONY
MODEL NO. : VGP-BMS30
APPLICANT : PRIMAX ELECTRONICS LTD.
TESTED : Aug. 8 ~ 18, 2005
TEST SAMPLE : ENGINEERING SAMPLE
STANDARDS : FCC Part 15, Subpart C (Section 15.247)
ANSI C63.4: 2003

The above equipment has been tested by **Advance Data Technology Corporation**, and found compliance with the requirement of the above standards. The test record, data evaluation & Equipment Under Test (EUT) configurations represented herein are true and accurate accounts of the measurements of the sample's EMC characteristics under the conditions specified in this report.

PREPARED BY : *Jessica Cheng* , **DATE:** Aug. 22, 2005
(Jessica Cheng)

TECHNICAL
ACCEPTANCE : *Ken Liu* , **DATE:** Aug. 22, 2005
Responsible for RF
(Ken Liu)

APPROVED BY : *Cody Chang* , **DATE:** Aug. 22, 2005
(Cody Chang / Deputy Manager)

2. SUMMARY OF TEST RESULTS

The EUT has been tested according to the following specifications:

APPLIED STANDARD: FCC Part 15, Subpart C			
STANDARD SECTION	TEST TYPE AND LIMIT	RESULT	REMARK
15.207	AC Power Conducted Emission	N/A	The EUT power from AA battery x2
15.247(a)(1)(iii)	Number of Hopping Frequency Used Spec.: At least 15 channels	PASS	Meet the requirement of limit.
15.247(a)(1)(iii)	Dwell Time on Each Channel Spec. : Max. 0.4 second within 31.6 second	PASS	Meet the requirement of limit.
15.247(a)(1)	1. Hopping Channel Separation Spec. : Min. 25 kHz or 20 dB bandwidth, whichever is greater (see Note 1) 2. Spectrum Bandwidth of a Frequency Hopping Sequence Spread Spectrum System	PASS	Meet the requirement of limit.
15.247(b)	Maximum Peak Output Power Spec.: max. 30dBm (see Note 1)	PASS	Meet the requirement of limit.
15.247(d)	Transmitter Radiated Emissions Spec.: Table 15.209	PASS	Meet the requirement of limit Minimum passing margin is -5.96 dB at 599.56 MHz
15.247(d)	Band Edge Measurement	PASS	Meet the requirement of limit.

NOTE: If The Frequency Hopping System operating in 2400-2483.5MHz band and the output power less than 125mW. The hopping channel carrier frequencies separated by a minimum of 25kHz or two-thirds of the 20dB bandwidth of hopping channel whichever is greater.



2.1 MEASUREMENT UNCERTAINTY

Where relevant, the following measurement uncertainty levels have been estimated for tests performed on the EUT as specified in CISPR 16-4:

This uncertainty represents an expanded uncertainty expressed at approximately the 95% confidence level using a coverage factor of $k=2$.

MEASUREMENT	UNCERTAINTY
Radiated emissions	3.86 dB

3. GENERAL INFORMATION

3.1 GENERAL DESCRIPTION OF EUT

PRODUCT	BLUETOOTH WIRELESS MOUSE
MODEL NO.	VGP-BMS30
POWER SUPPLY	3Vdc from AA battery x2
MODULATION TYPE	GFSK
MODULATION TECHNOLOGY	FHSS
TRANSFER RATE	723Kbps
FREQUENCY RANGE	2402 MHz ~ 2480 MHz
NUMBER OF CHANNEL	79
OUTPUT POWER	1.879mW
ANTENNA TYPE	Inverted-F Antenna with -3.04dBi gain
DATA CABLE	N/A
I/O PORTS	N/A

NOTE:

1. The EUT is a wireless Mouse, with Bluetooth technology.
2. The above EUT information was declared by the manufacturer and for more detailed features description, please refer to the manufacturer's specifications or User's Manual.



3.2 DESCRIPTION OF TEST MODES

79 channels are provided to this EUT:

CHANNEL	FREQ. (MHz)	CHANNEL	FREQ. (MHz)	CHANNEL	FREQ. (MHz)	CHANNEL	FREQ. (MHz)
0	2402	20	2422	40	2442	60	2462
1	2403	21	2423	41	2443	61	2463
2	2404	22	2424	42	2444	62	2464
3	2405	23	2425	43	2445	63	2465
4	2406	24	2426	44	2446	64	2466
5	2407	25	2427	45	2447	65	2467
6	2408	26	2428	46	2448	66	2468
7	2409	27	2429	47	2449	67	2469
8	2410	28	2430	48	2450	68	2470
9	2411	29	2431	49	2451	69	2471
10	2412	30	2431	50	2452	70	2472
11	2413	31	2433	51	2453	71	2473
12	2414	32	2434	52	2454	72	2474
13	2415	33	2435	53	2455	73	2475
14	2416	34	2436	54	2456	74	2476
15	2417	35	2437	55	2457	75	2477
16	2418	36	2438	56	2458	76	2478
17	2419	37	2439	57	2459	77	2479
18	2420	38	2440	58	2460	78	2480
19	2421	39	2441	59	2461		

3.2.1 CONFIGURATION OF SYSTEM UNDER TEST

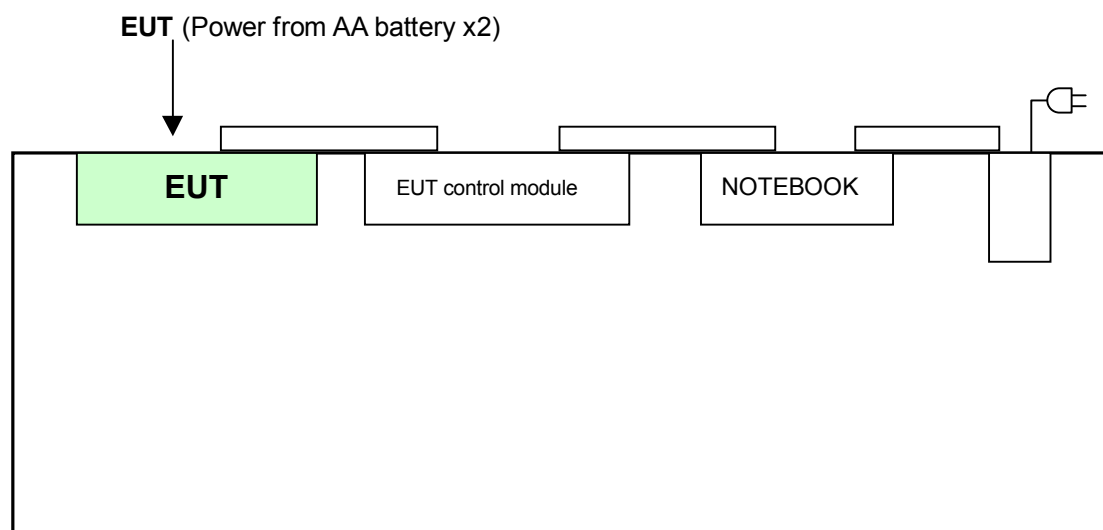

Note:

EUT has no build-in test mode available, a EUT control module was supplied by the manufacture during the test to control the EUT output channel and transmission mode.



3.2.2 TEST MODE APPLICABILITY AND TESTED CHANNEL DETAIL

EUT CONFIGURE MODE	Applicable to				Description
	PLC	RE<1G	RE≥1G	APCM	
-	Note	√	√	√	N/A

Where **PLC**: Power Line Conducted Emission **RE<1G**: Radiated Emission below 1GHz
RE≥1G: Radiated Emission above 1GHz **APCM**: Antenna Port Conducted Measurement

Note: No need to concern of Conducted Emission due to the EUT is powered by battery.

RADIATED EMISSION TEST (BELOW 1 GHz):

- Pre-Scan has been conducted to determine the worst-case mode from all possible combinations between available modulations and packet types.
- Following channel(s) was (were) selected for the final test as listed below.

AVAILABLE CHANNEL	TESTED CHANNEL	MODULATION TECHNOLOGY	MODULATION TYPE	PACKET TYPE
0 to 78	78	FHSS	GFSK	DH3

RADIATED EMISSION TEST (ABOVE 1 GHz):

- Pre-Scan has been conducted to determine the worst-case mode from all possible combinations between available modulations and packet types.
- Following channel(s) was (were) selected for the final test as listed below.

AVAILABLE CHANNEL	TESTED CHANNEL	MODULATION TECHNOLOGY	MODULATION TYPE	PACKET TYPE
0 to 78	0, 39, 78	FHSS	GFSK	DH3

**BANDEDGE MEASUREMENT:**

- Pre-Scan has been conducted to determine the worst-case mode from all possible combinations between available modulations and packet types.
- Following channel(s) was (were) selected for the final test as listed below.

AVAILABLE CHANNEL	TESTED CHANNEL	MODULATION TECHNOLOGY	MODULATION TYPE	PACKET TYPE
0 to 78	0, 78	FHSS	GFSK	DH3

ANTENNA PORT CONDUCTED MEASUREMENT:

- Pre-Scan has been conducted to determine the worst-case mode from all possible combinations between available modulations and packet types.
- Following channel(s) was (were) selected for the final test as listed below.

AVAILABLE CHANNEL	TESTED CHANNEL	MODULATION TECHNOLOGY	MODULATION TYPE
0 to 78	0, 39, 78	FHSS	GFSK



3.3.3 GENERAL DESCRIPTION OF APPLIED STANDARDS

The EUT is a BLUETOOTH WIRELESS MOUSE. According to the specifications of the manufacturer, it must comply with the requirements of the following standards:

FCC Part 15, Subpart C. (15.247)

ANSI C63.4- 2003

All test items have been performed and recorded as per the above standards.

NOTE: The EUT is also considered as a kind of computer peripheral, because the connection to computer is necessary for typical use. It has been verified to comply with the requirements of FCC Part 15, Subpart B, Class B (DoC). The test report has been issued separately.

3.3.4 DESCRIPTION OF SUPPORT UNITS

The EUT has been tested as an independent unit together with other necessary accessories or support units. The following support units or accessories were used to form a representative test configuration during the tests.

NO.	PRODUCT	BRAND	MODEL NO.	SERIAL NO.	FCC ID
1	DELL Notebook	DELL	D600	CN-0G5152-48643-487-0213	N/A

NO.	SIGNAL CABLE DESCRIPTION OF THE ABOVE SUPPORT UNITS
1	N/A

NOTE: All power cords of the above support units are non-shielded (1.8m).



4. TEST TYPES AND RESULTS

4.1 CONDUCTED EMISSION MEASUREMENT

NA

4.2 RADIATED EMISSION MEASUREMENT

4.2.1 LIMITS OF RADIATED EMISSION MEASUREMENT

Emissions radiated outside of the specified bands, shall be according to the general radiated limits in 15.209 as following:

FREQUENCIES (MHz)	FIELD STRENGTH (microvolts/meter)	MEASUREMENT DISTANCE (meters)
0.009 ~ 0.490	2400/F(kHz)	300
0.490 ~ 1.705	24000/F(kHz)	30
1.705 ~ 30.0	30	30
30 ~ 88	100	3
88 ~ 216	150	3
216 ~ 960	200	3
Above 960	500	3

NOTE:

1. The lower limit shall apply at the transition frequencies.
2. Emission level (dBuV/m) = 20 log Emission level (uV/m).
3. As shown in 15.35(b), for frequencies above 1000MHz, the field strength limits are based on average detector, however, the peak field strength of any emission shall not exceed the maximum permitted average limits, specified above by more than 20dB under any condition of modulation.



4.2.2 TEST INSTRUMENTS

DESCRIPTION & MANUFACTURER	MODEL NO.	SERIAL NO.	CALIBRATED UNTIL
HP Preamplifier	8447D	2432A03504	May 22, 2006
HP Preamplifier	8449B	3008A01924	Sep. 19, 2005
HP Preamplifier	8449B	3008A01638	Sep. 30, 2005
SCHWARZBECK Tunable Dipole Antenna	VHA 9103	NA	Oct. 29, 2005
SCHWARZBECK Tunable Dipole Antenna	UHA 9105	977	
ROHDE & SCHWARZ TEST RECEIVER	ESI7	836697/012	Nov. 05, 2005
Schwarzbeck Antenna	VULB 9168	137	Feb. 27, 2006
Schwarzbeck Antenna	VHBA 9123	480	Apr. 11, 2006
EMCO Horn Antenna	3115	6714	Oct. 28, 2005
EMCO Horn Antenna	3115	9312-4192	Feb. 28, 2006
ADT. Turn Table	TT100	0306	NA
ADT. Tower	AT100	0306	NA
Software	ADT_Radiated_V6	NA	NA
TIMES RF cable	LL142	CABLE-CH6-01	Dec. 19, 2005

- NOTE:**
1. The calibration interval of the above test instruments is 12 months. And the calibrations are traceable to NML/ROC and NIST/USA.
 2. The horn antenna and HP preamplifier (model: 8449B) are used only for the measurement of emission frequency above 1GHz if tested.
 3. The test was performed in ADT Chamber No. 6.
 4. The Industry Canada Reference No. IC 3789-6.
 5. This uncertainty represents an expanded uncertainty expressed at approximately the 95% confidence level using a coverage factor of k=2.

4.2.3 TEST PROCEDURES

- a. The EUT was placed on the top of a rotating table 0.8 meters above the ground at a 3 meter semi-anechoic chamber. The table was rotated 360 degrees to determine the position of the highest radiation.
- b. The EUT was set 3 meters away from the interference-receiving antenna, which was mounted on the top of a variable-height antenna tower.
- c. The antenna is a broadband antenna, and its height is varied from one meter to four meters above the ground to determine the maximum value of the field strength. Both horizontal and vertical polarizations of the antenna are set to make the measurement.
- d. For each suspected emission, the EUT was arranged to its worst case and then the antenna was tuned to heights from 1 meter to 4 meters and the rotatable table was turned from 0 degrees to 360 degrees to find the maximum reading.
- e. The test-receiver system was set to Peak Detect Function and Specified Bandwidth with Maximum Hold Mode.
- f. If the emission level of the EUT in peak mode was lower than the limit specified, then testing could be stopped and the peak values of the EUT would be reported. Otherwise the emissions would be re-tested one by one using peak, quasi-peak or average method as specified and then reported in a data sheet.

NOTE:

1. The resolution bandwidth and video bandwidth of test receiver/spectrum analyzer is 120kHz for Quasi-peak detection at frequency below 1GHz.
2. The resolution bandwidth and video bandwidth of test receiver/spectrum analyzer is 1 MHz for Peak detection (PK) at frequency above 1GHz.

4.2.4 DEVIATION FROM TEST STANDARD

No deviation

4.2.5 TEST SETUP

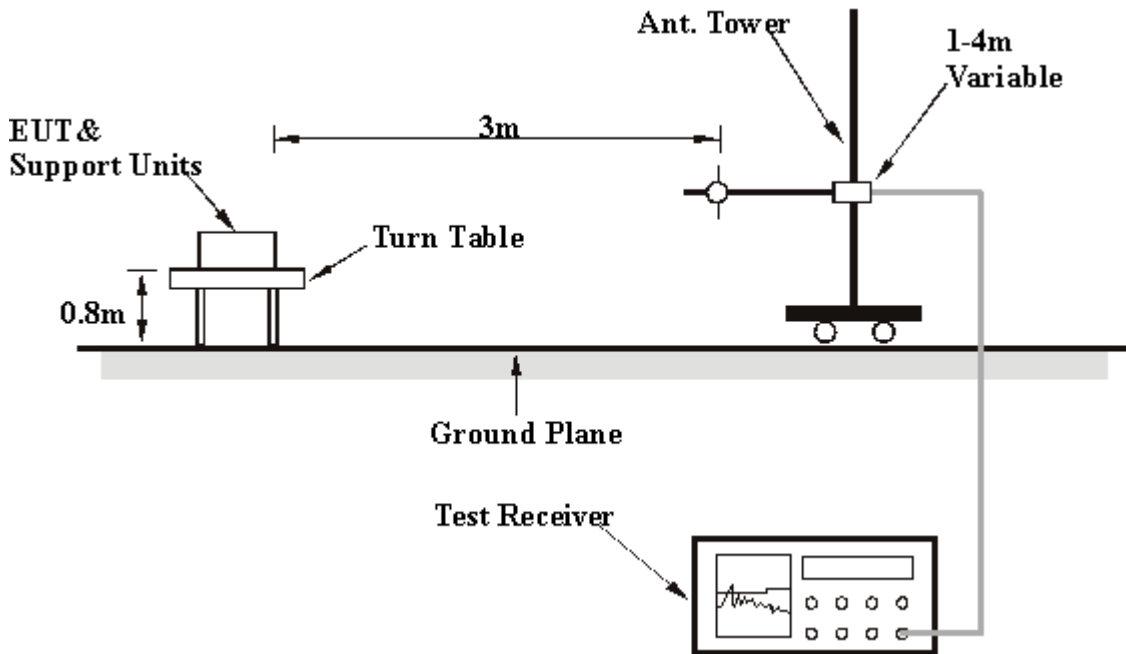

For the actual test configuration, please refer to the related item – Photographs of the Test Configuration.

4.2.6 EUT OPERATING CONDITIONS

Set the transmitter part of EUT under transmission condition continuously at specific channel frequency.

4.2.7 TEST RESULTS

Below 1GHz Worst-Case Data

EUT	BLUETOOTH WIRELESS MOUSE	MEASUREMENT DETAIL	
MODEL	VGP-BMS30	FREQUENCY RANGE	Below 1 GHz
CHANNEL	78	MODULATION TYPE	GFSK
INPUT POWER	3Vdc	DETECTOR FUNCTION	Quasi-Peak
TESTED BY	Jamison Chan	ENVIRONMENTAL CONDITIONS	25deg. C, 70% RH, 998hPa

ANTENNA POLARITY & TEST DISTANCE: HORIZONTAL AT 3 M

No.	Freq. (MHz)	Emission Level (dBuV/m)	Limit (dBuV/m)	Margin (dB)	Antenna Height (m)	Table Angle (Degree)	Raw Value (dBuV)	Correction Factor (dB/m)
1	133.03	35.47 QP	43.50	-8.03	1.06 H	202	17.97	17.50
2	566.51	33.79 QP	46.00	-12.21	1.88 H	97	6.96	26.83
3	599.56	40.04 QP	46.00	-5.96	1.36 H	241	12.32	27.73
4	646.21	34.89 QP	46.00	-11.11	1.53 H	229	6.64	28.25
5	768.68	35.73 QP	46.00	-10.27	1.04 H	286	5.51	30.22
6	867.82	33.66 QP	46.00	-12.34	1.11 H	319	1.94	31.72

ANTENNA POLARITY & TEST DISTANCE: VERTICAL AT 3 M

No.	Freq. (MHz)	Emission Level (dBuV/m)	Limit (dBuV/m)	Margin (dB)	Antenna Height (m)	Table Angle (Degree)	Raw Value (dBuV)	Correction Factor (dB/m)
1	41.66	30.77 QP	40.00	-9.23	1.50 V	85	11.61	19.16
2	107.76	34.38 QP	43.50	-9.12	1.00 V	352	19.45	14.93
3	593.73	38.09 QP	46.00	-7.91	1.50 V	184	10.52	27.57
4	799.78	33.13 QP	46.00	-12.87	1.50 V	193	2.84	30.29
5	867.82	36.90 QP	46.00	-9.10	1.50 V	1	5.18	31.72
6	937.80	32.52 QP	46.00	-13.48	1.50 V	157	0.07	32.45

- REMARKS:**
1. Emission level(dBuV/m)=Raw Value(dBuV) + Correction Factor(dB/m)
 2. Correction Factor(dB/m) = Antenna Factor (dB/m) + Cable Factor (dB)
 3. The other emission levels were very low against the limit.
 4. Margin value = Emission level – Limit value.



1 ~ 25GHz Worst-Case Data

EUT	BLUETOOTH WIRELESS MOUSE	MEASUREMENT DETAIL	
MODEL	VGP-BMS30	FREQUENCY RANGE	1 ~ 25 GHz
CHANNEL	0	MODULATION TYPE	GFSK
INPUT POWER	3Vdc	DETECTOR FUNCTION	Peak(PK) Average (AV)
TESTED BY	Jamison Chan	ENVIRONMENTAL CONDITIONS	25deg. C, 70% RH, 998hPa

ANTENNA POLARITY & TEST DISTANCE: HORIZONTAL AT 3 M								
No.	Freq. (MHz)	Emission Level (dBuV/m)	Limit (dBuV/m)	Margin (dB)	Antenna Height (m)	Table Angle (Degree)	Raw Value (dBuV)	Correction Factor (dB/m)
1	1602.00	44.30 PK	74.00	-29.70	1.06 H	155	16.02	28.28
1	1602.00	37.70 AV	54.00	-16.30	1.06 H	155	9.42	28.28
2	2390.00	36.40 PK	74.00	-37.60	1.00 H	138	5.65	30.75
2	2390.00	31.15 AV	54.00	-22.85	1.00 H	138	0.40	30.75
3	*2402.00	91.54 PK			1.00 H	138	60.74	30.80
3	*2402.00	57.04 AV			1.00 H	138	26.24	30.80
4	4804.00	50.18 PK	74.00	-23.82	1.19 H	165	13.95	36.23
4	4804.00	15.68 AV	54.00	-38.32	1.19 H	165	-20.55	36.23

ANTENNA POLARITY & TEST DISTANCE: VERTICAL AT 3 M								
No.	Freq. (MHz)	Emission Level (dBuV/m)	Limit (dBuV/m)	Margin (dB)	Antenna Height (m)	Table Angle (Degree)	Raw Value (dBuV)	Correction Factor (dB/m)
1	1602.00	42.50 PK	74.00	-31.50	1.28 V	198	14.22	28.28
1	1602.00	35.87 AV	54.00	-18.13	1.28 V	198	7.59	28.28
2	2390.00	34.70 PK	74.00	-39.30	1.06 V	184	3.95	30.75
2	2390.00	29.45 AV	54.00	-24.55	1.06 V	184	-1.30	30.75
3	*2402.00	89.84 PK			1.06 V	184	59.04	30.80
3	*2402.00	55.34 AV			1.06 V	184	24.54	30.80
4	4804.00	54.46 PK	74.00	-19.54	1.00 V	209	18.23	36.23
4	4804.00	19.96 AV	54.00	-34.04	1.00 V	209	-16.27	36.23

- REMARKS:**
1. Emission level(dBuV/m)=Raw Value(dBuV) + Correction Factor(dB/m)
 2. Correction Factor(dB/m) = Antenna Factor (dB/m) + Cable Factor (dB)
 3. The other emission levels were very low against the limit.
 4. Margin value = Emission level – Limit value.
 5. The DH3 packet was the worse case duty cycle for a transmit dwell time on a channel, based upon bluetooth theory the transmitter is on 0.625*3 per 247 ms per channel. Therefore, the duty cycle be equal to: $20\log(1.875/100) = -34.5\text{dB}$
 6. Average value = peak reading $-20\log(\text{duty cycle})$



EUT	BLUETOOTH WIRELESS MOUSE	MEASUREMENT DETAIL	
MODEL	VGP-BMS30	FREQUENCY RANGE	1 ~ 25 GHz
CHANNEL	39	MODULATION TYPE	GFSK
INPUT POWER	3Vdc	DETECTOR FUNCTION	Peak(PK) Average (AV)
TESTED BY	Jamison Chan	ENVIRONMENTAL CONDITIONS	25deg. C, 70% RH, 998hPa

ANTENNA POLARITY & TEST DISTANCE: HORIZONTAL AT 3 M								
No.	Freq. (MHz)	Emission Level (dBuV/m)	Limit (dBuV/m)	Margin (dB)	Antenna Height (m)	Table Angle (Degree)	Raw Value (dBuV)	Correction Factor (dB/m)
1	1628.00	45.02 PK	74.00	-28.98	1.10 H	137	16.68	28.34
1	1628.00	40.10 AV	54.00	-13.90	1.10 H	137	11.76	28.34
2	*2441.00	94.18 PK			1.11 H	172	63.21	30.97
2	*2441.00	59.68 AV			1.11 H	172	28.71	30.97
3	4882.00	51.48 PK	74.00	-22.52	1.10 H	173	15.13	36.35
3	4882.00	16.98 AV	54.00	-37.02	1.10 H	173	-19.37	36.35

ANTENNA POLARITY & TEST DISTANCE: VERTICAL AT 3 M								
No.	Freq. (MHz)	Emission Level (dBuV/m)	Limit (dBuV/m)	Margin (dB)	Antenna Height (m)	Table Angle (Degree)	Raw Value (dBuV)	Correction Factor (dB/m)
1	1628.00	42.81 PK	74.00	-31.19	1.14 V	324	14.47	28.34
1	1628.00	36.62 AV	54.00	-17.38	1.14 V	324	8.28	28.34
2	*2441.00	91.48 PK			1.64 V	177	60.51	30.97
2	*2441.00	56.98 AV			1.64 V	177	26.01	30.97
3	4882.00	55.81 PK	74.00	-18.19	1.09 V	219	19.46	36.35
3	4882.00	21.31 AV	54.00	-32.69	1.09 V	219	-15.04	36.35

- REMARKS:**
1. Emission level(dBuV/m)=Raw Value(dBuV) + Correction Factor(dB/m)
 2. Correction Factor(dB/m) = Antenna Factor (dB/m) + Cable Factor (dB)
 3. The other emission levels were very low against the limit.
 4. Margin value = Emission level – Limit value.
 5. The DH3 packet was the worse case duty cycle for a transmit dwell time on a channel, based upon bluetooth theory the transmitter is on 0.625*3 per 247 ms per channel. Therefore, the duty cycle be equal to: $20\log(1.875/100) = -34.5\text{dB}$
 6. Average value = peak reading $-20\log(\text{duty cycle})$



EUT	BLUETOOTH WIRELESS MOUSE	MEASUREMENT DETAIL	
MODEL	VGP-BMS30	FREQUENCY RANGE	1 ~ 25 GHz
CHANNEL	78	MODULATION TYPE	GFSK
INPUT POWER	3Vdc	DETECTOR FUNCTION	Peak(PK) Average (AV)
TESTED BY	Jamison Chan	ENVIRONMENTAL CONDITIONS	25deg. C, 70% RH, 998hPa

ANTENNA POLARITY & TEST DISTANCE: HORIZONTAL AT 3 M

No.	Freq. (MHz)	Emission Level (dBuV/m)	Limit (dBuV/m)	Margin (dB)	Antenna Height (m)	Table Angle (Degree)	Raw Value (dBuV)	Correction Factor (dB/m)
1	1654.00	43.97 PK	74.00	-30.03	1.00 H	164	15.58	28.39
1	1654.00	38.89 AV	54.00	-15.11	1.00 H	164	10.50	28.39
2	*2480.00	93.86 PK			1.08 H	177	62.73	31.13
2	*2480.00	59.36 AV			1.08 H	177	28.23	31.13
3	2483.50	44.01 PK	74.00	-29.99	1.08 H	177	12.86	31.15
3	2483.50	39.98 AV	54.00	-14.02	1.08 H	177	8.83	31.15
4	4960.00	50.91 PK	74.00	-23.09	1.00 H	178	14.43	36.48
4	4960.00	16.41 AV	54.00	-37.59	1.00 H	178	-20.07	36.48

ANTENNA POLARITY & TEST DISTANCE: VERTICAL AT 3 M

No.	Freq. (MHz)	Emission Level (dBuV/m)	Limit (dBuV/m)	Margin (dB)	Antenna Height (m)	Table Angle (Degree)	Raw Value (dBuV)	Correction Factor (dB/m)
1	1654.00	44.26 PK	74.00	-29.74	1.10 V	339	15.87	28.39
1	1654.00	39.52 AV	54.00	-14.48	1.10 V	339	11.13	28.39
2	*2480.00	91.51 PK			1.23 V	179	60.38	31.13
2	*2480.00	57.01 AV			1.23 V	179	25.88	31.13
3	2483.50	41.66 PK	74.00	-32.34	1.23 V	179	10.51	31.15
3	2483.50	37.63 AV	54.00	-16.37	1.23 V	179	6.48	31.15
4	4960.00	56.67 PK	74.00	-17.33	1.10 V	223	20.19	36.48
4	4960.00	22.17 AV	54.00	-31.83	1.10 V	223	-14.31	36.48

- REMARKS:**
1. Emission level(dBuV/m)=Raw Value(dBuV) + Correction Factor(dB/m)
 2. Correction Factor(dB/m) = Antenna Factor (dB/m) + Cable Factor (dB)
 3. The other emission levels were very low against the limit.
 4. Margin value = Emission level – Limit value.
 5. The DH3 packet was the worse case duty cycle for a transmit dwell time on a channel, based upon bluetooth theory the transmitter is on 0.625*3 per 247 ms per channel. Therefore, the duty cycle be equal to: $20\log(1.875/100) = -34.5\text{dB}$
 6. Average value = peak reading $-20\log(\text{duty cycle})$



4.3 NUMBER OF HOPPING FREQUENCY USED

4.3.1 LIMIT OF HOPPING FREQUENCY USED

At least 15 channels frequencies, and should be equally spaced.

4.3.2 TEST INSTRUMENTS

Description & Manufacturer	Model No.	Serial No.	Calibrated Until
SPECTRUM ANALYZER	FSP 40	100036	Mar 20. 2006

NOTE: The calibration interval of the above test instruments is 12 months and the calibrations are traceable to NML/ROC and NIST/USA.

4.3.3 TEST PROCEDURES

- a. Check the calibration of the measuring instrument (SA) using either an internal calibrator or a known signal from an external generator.
- b. Turn on the EUT and connect its antenna terminal to measurement via a low loss cable. Then set it to any one measured frequency within its operating range and make sure the instrument is operated in its linear range.
- c. Set the SA on MaxHold Mode, and then keep the EUT in hopping mode. Record all the signals from each channel until each one has been recorded.
- d. Set the SA on View mode and then plot the result on SA screen.
- e. Repeat above procedures until all frequencies measured were complete.

4.3.4 DEVIATION FROM TEST STANDARD

No deviation.

4.3.5 TEST SETUP



4.3.6 TEST RESULTS

There are 79 hopping frequencies in the hopping mode. Please refer to next one page for the test result. On the plots, it shows that the hopping frequencies are equally spaced.

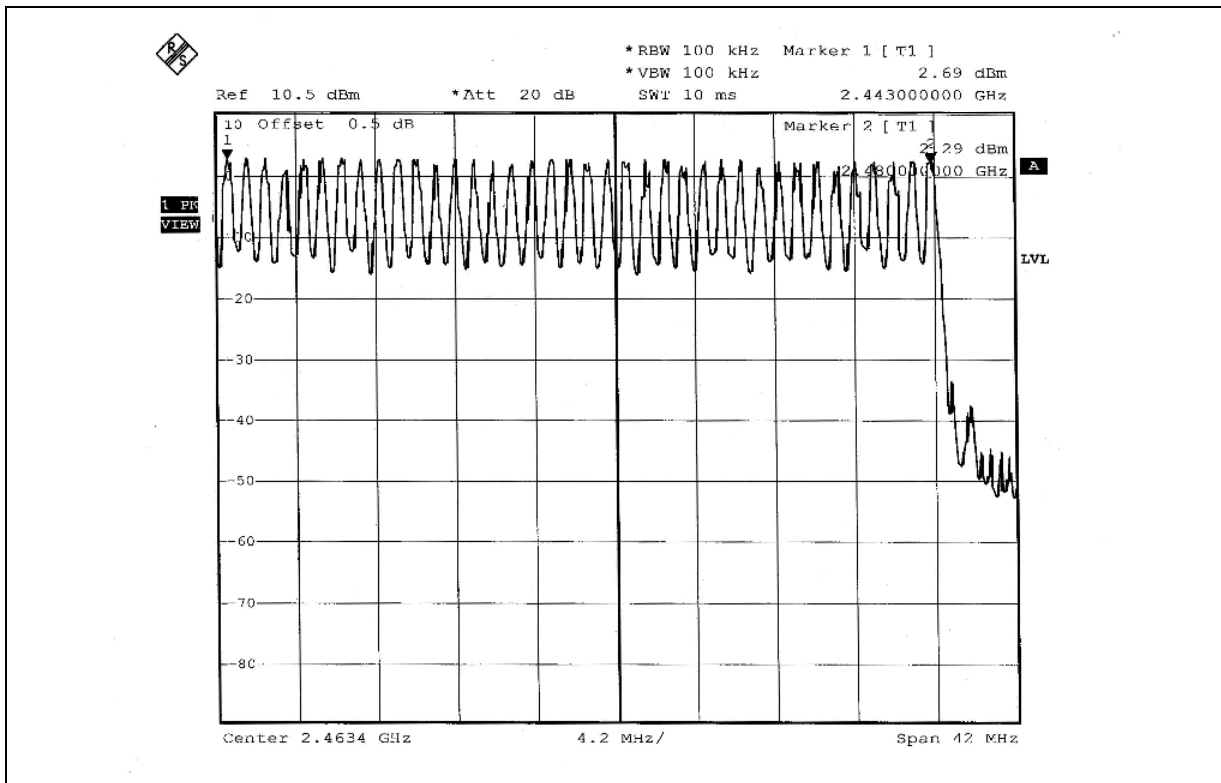
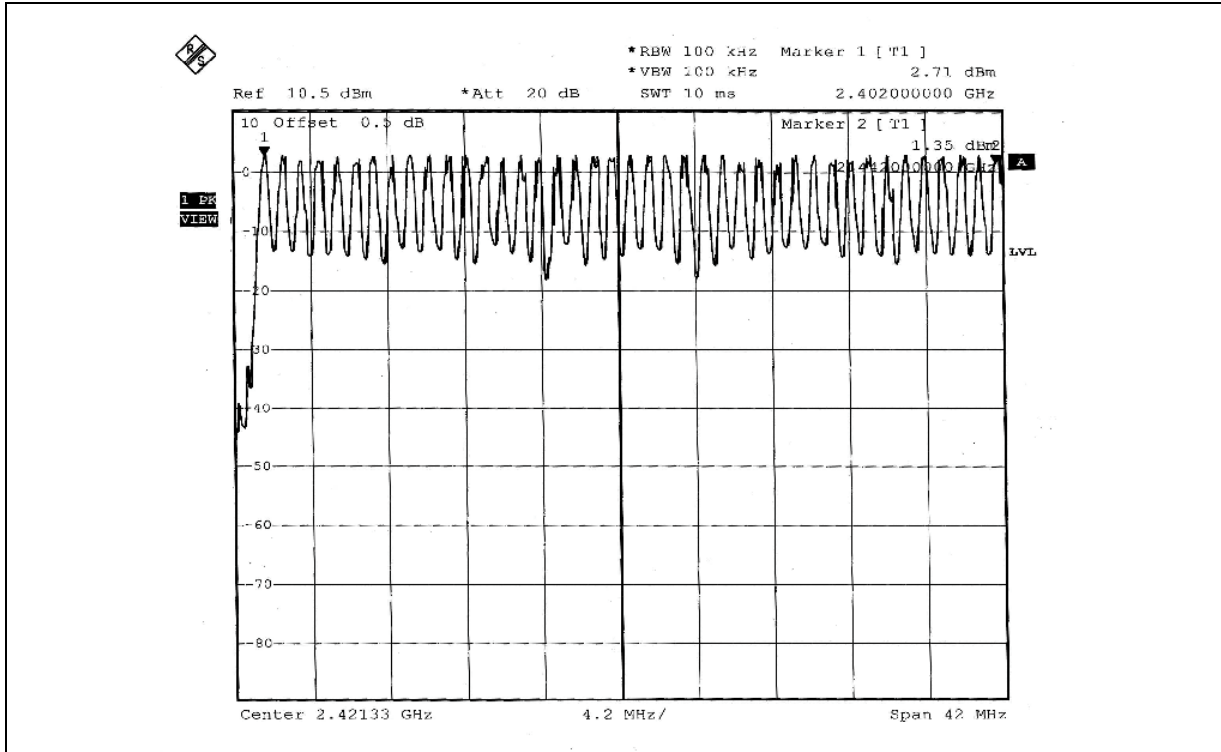



4.4 DWELL TIME ON EACH CHANNEL

4.4.1 LIMIT OF DWELL TIME USED

The average time of occupancy on any channel shall not be greater than 0.4 seconds within a period of 0.4 seconds multiplied by the number of hopping channels employed.

4.4.2 TEST INSTRUMENTS

Description & Manufacturer	Model No.	Serial No.	Calibrated Until
SPECTRUM ANALYZER	FSP 40	100036	Mar 20. 2006

NOTE: The calibration interval of the above test instruments is 12 months and the calibrations are traceable to NML/ROC and NIST/USA.

4.4.3 TEST PROCEDURES

- a. Check the calibration of the measuring instrument (SA) using either an internal calibrator or a known signal from an external generator.
- b. Turn on the EUT and connect its antenna terminal to measurement via a low loss cable. Then set it to any one measured frequency within its operating range and make sure the instrument is operated in its linear range.
- c. Adjust the center frequency of SA on any frequency be measured and set SA to zero span mode. And then, set RBW and VBW of spectrum analyzer to proper value.
- d. Measure the time duration of one transmission on the measured frequency. And then plot the result with time difference of this time duration.
- e. Repeat above procedures until all different time-slot modes have been completed.

4.4.4 DEVIATION FROM TEST STANDARD

No deviation.

4.4.5 TEST SETUP

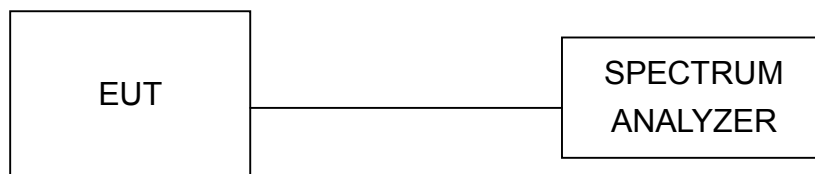

4.4.6 TEST RESULTS

Mode	Number of transmission in a 31.6 (79Hopping*0.4)	Length of transmission time (msec)	Result (msec)	Limit (msec)
DH1	50 (times / 5 sec) *6.32=316.00 times	0.592	187.072	400
DH3	24 (times / 5 sec) *6.32=151.68 times	1.850	280.608	400

NOTE: Test plots of the transmitting time slot are shown on next 2 pages.



DH1

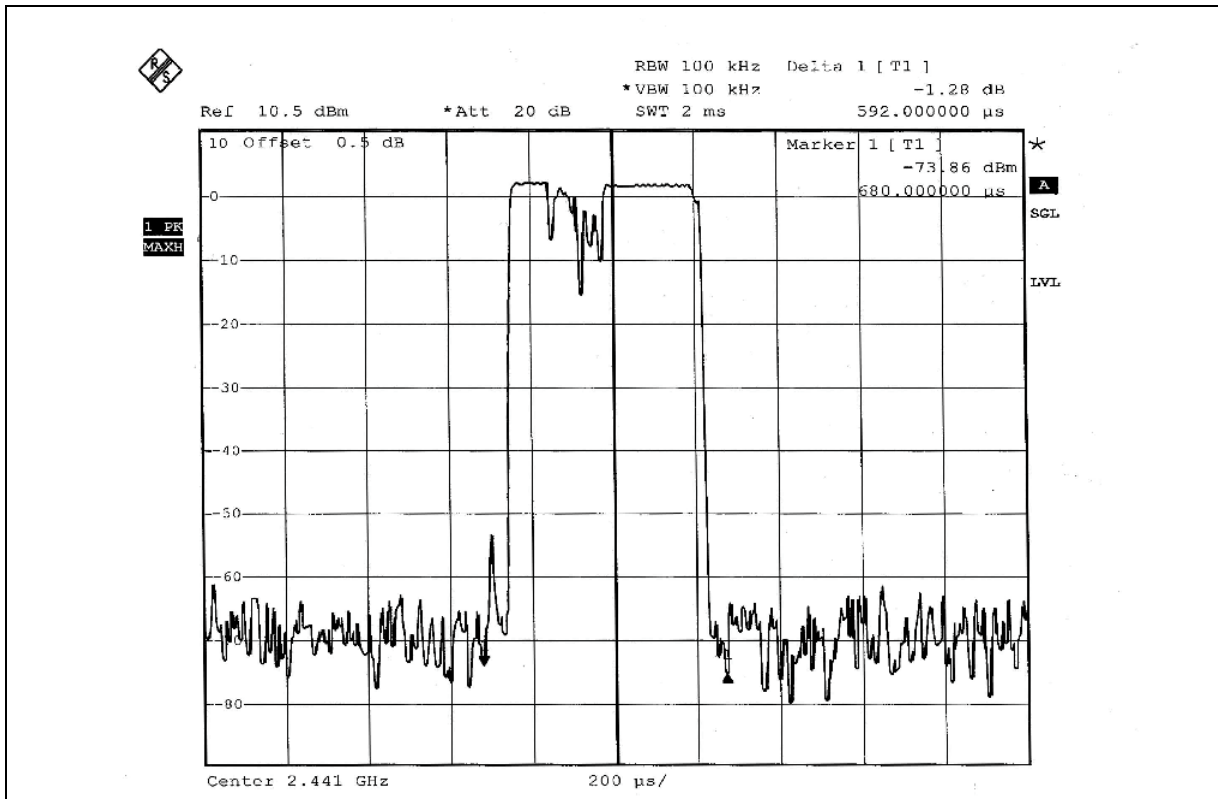
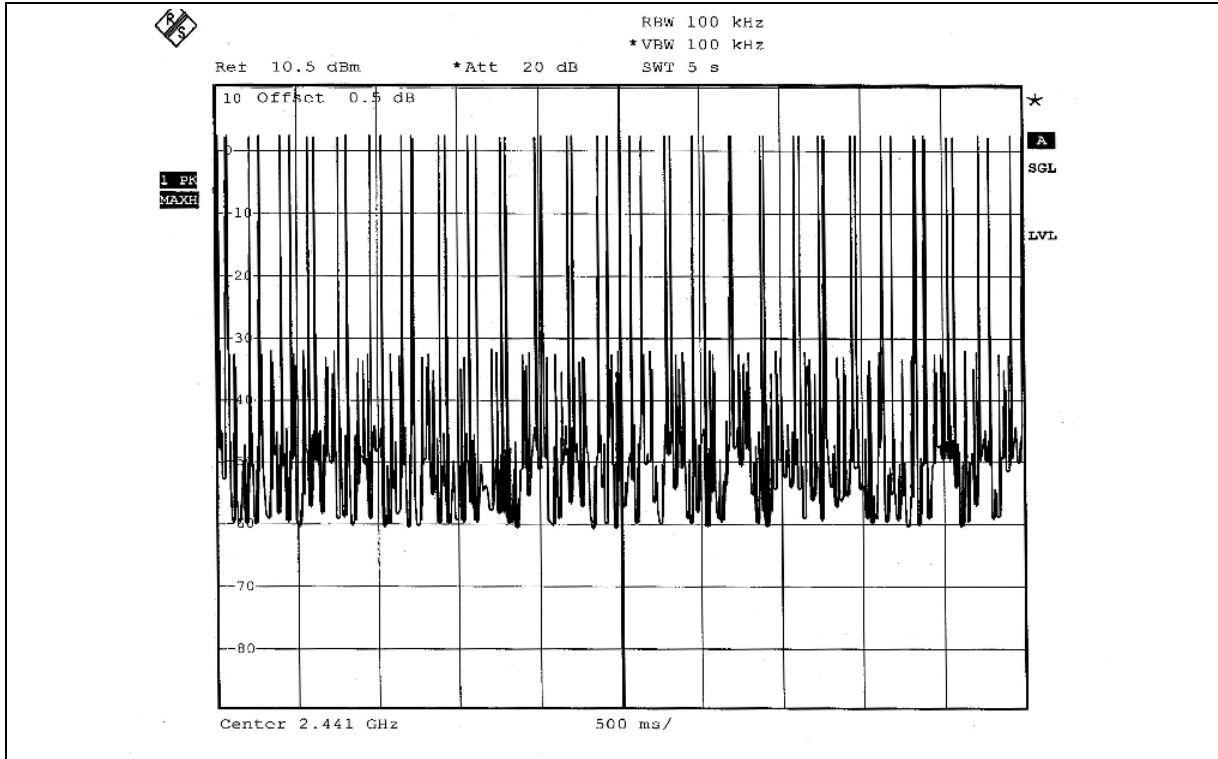



DH3

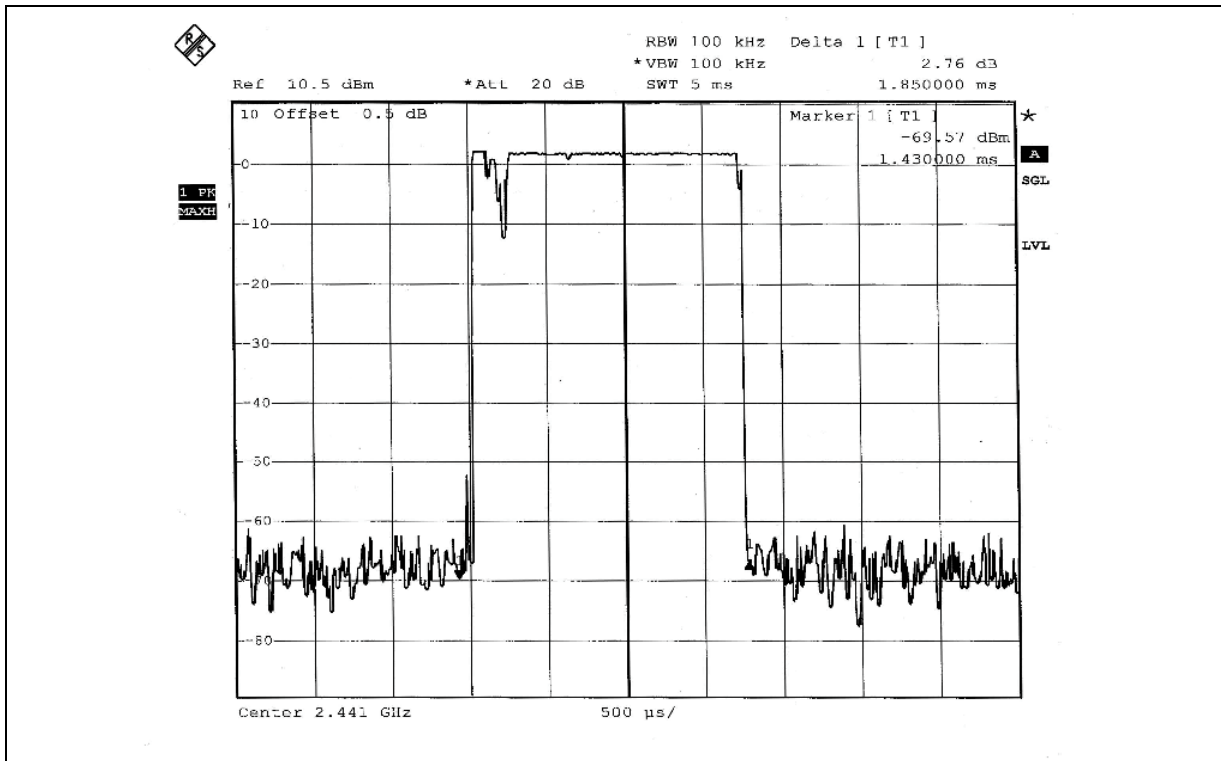
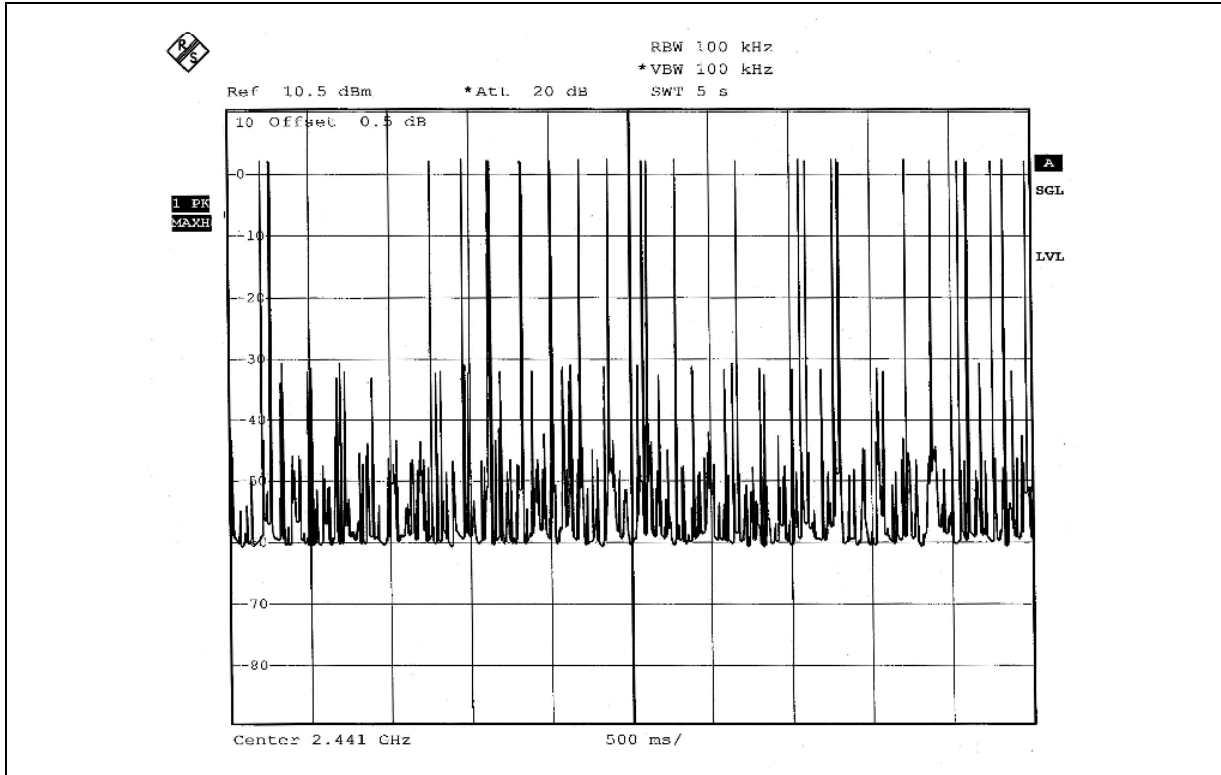



4.5 CHANNEL BANDWIDTH

4.5.1 LIMITS OF CHANNEL BANDWIDTH

For frequency hopping system operating in the 2400-2483.5MHz, If the 20dB bandwidth of hopping channel is greater than 25kHz, 20dB bandwidth of hopping channel shall be a minimum limit for the hopping channel separation.

4.5.2 TEST INSTRUMENTS

Description & Manufacturer	Model No.	Serial No.	Calibrated Until
SPECTRUM ANALYZER	FSP 40	100036	Mar 20. 2006

NOTE: The calibration interval of the above test instruments is 12 months and the calibrations are traceable to NML/ROC and NIST/USA.

4.5.3 TEST PROCEDURE

- a. Check the calibration of the measuring instrument using either an internal calibrator or a known signal from an external generator.
- b. Turn on the EUT and connect it to measurement instrument. Then set it to any one convenient frequency within its operating range. Set a reference level on the measuring instrument equal to the highest peak value.
- c. Measure the frequency difference of two frequencies that were attenuated 20dB from the reference level. Record the frequency difference as the emission bandwidth.
- d. Repeat above procedures until all frequencies measured were complete.



4.5.4 DEVIATION FROM TEST STANDARD

No deviation.

4.5.5 TEST SETUP



4.5.6 EUT OPERATING CONDITION

The software provided by client enabled the EUT to transmit and receive data at lowest, middle and highest channel frequencies individually.

4.5.7 TEST RESULTS

EUT	BLUETOOTH WIRELESS MOUSE	MODEL	VGP-BMS30
MODULATION TYPE	GFSK	ENVIRONMENTAL CONDITIONS	27deg. C, 70%RH, 998hPa
INPUT POWER	3Vdc	TESTED BY	Jamison Chan

CHANNEL	CHANNEL FREQUENCY (MHz)	20dB BANDWIDTH (MHz)
0	2402	0.975
39	2441	0.966
78	2480	0.966



CH 0

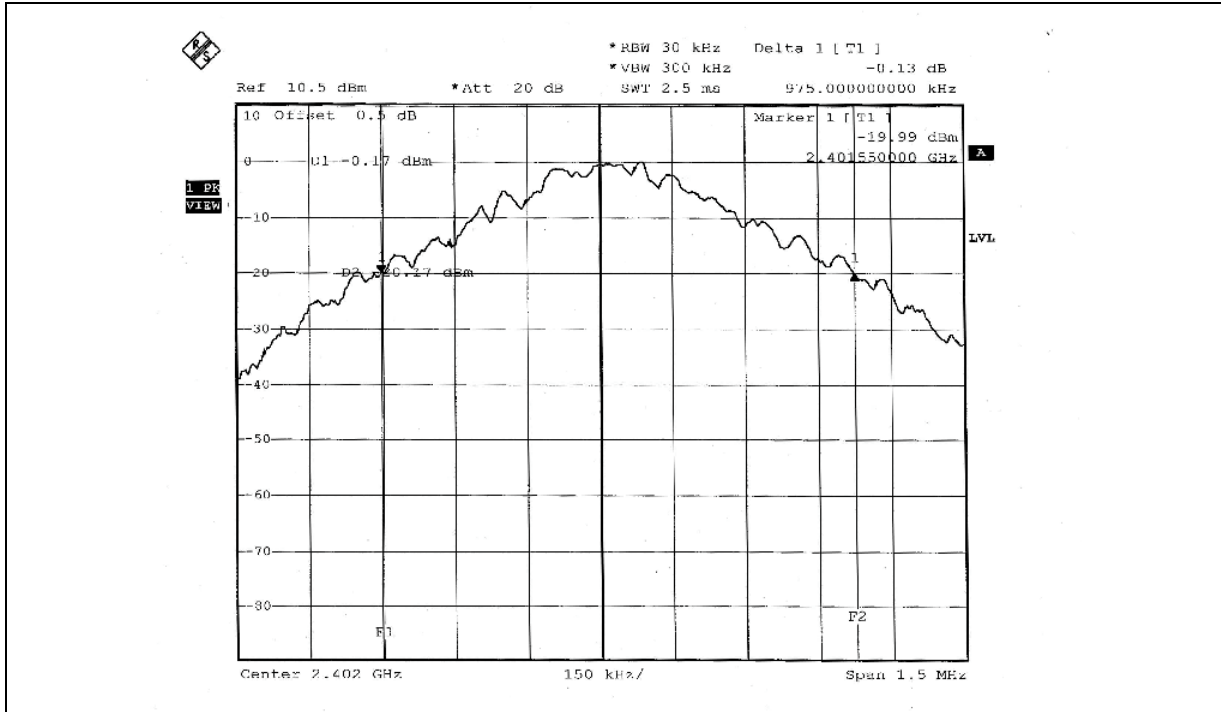

CH 39

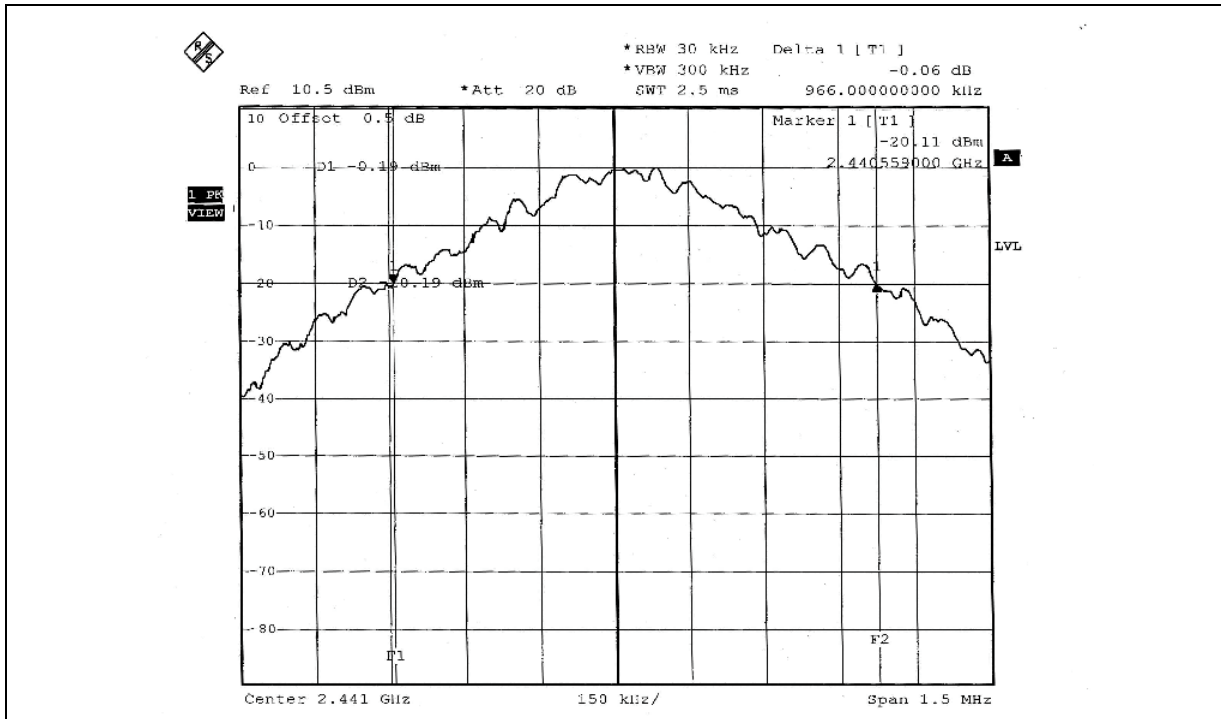



CH 78

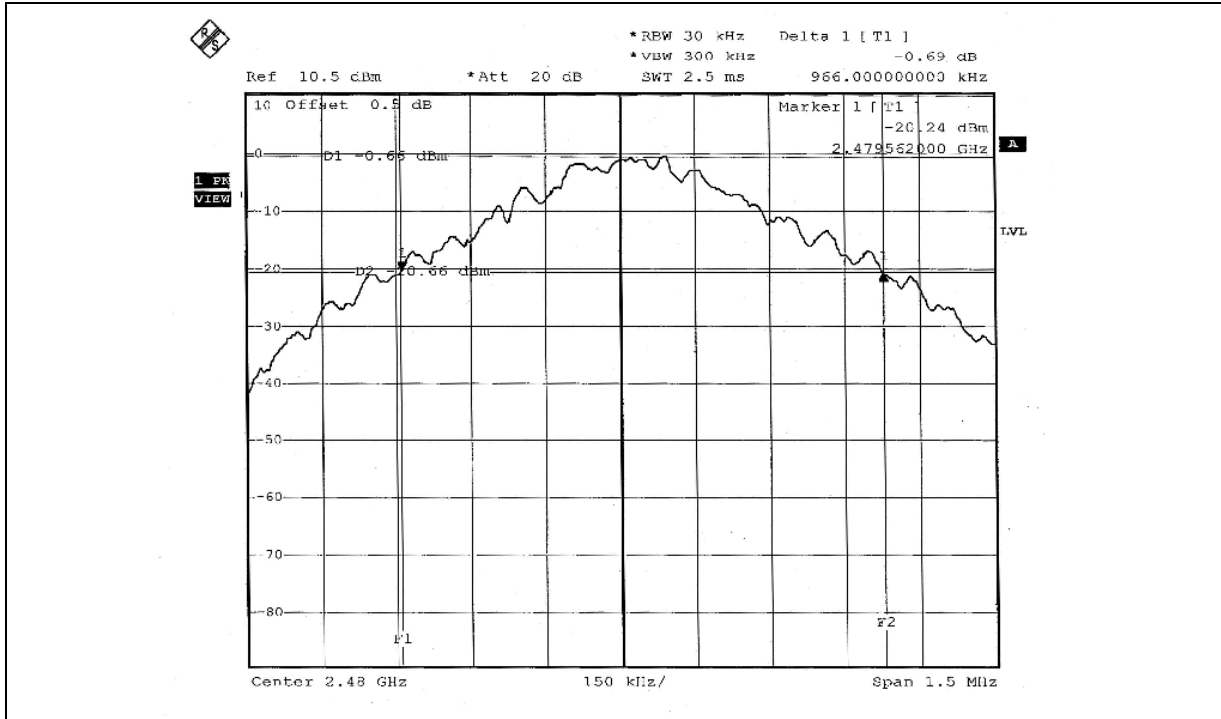



4.6 HOPPING CHANNEL SEPARATION

4.6.1 LIMIT OF HOPPING CHANNEL SEPARATION

At least 25kHz or 20dB hopping channel bandwidth (whichever is greater).

4.6.2 TEST INSTRUMENTS

Description & Manufacturer	Model No.	Serial No.	Calibrated Until
SPECTRUM ANALYZER	FSP 40	100036	Mar 20. 2006

NOTE: The calibration interval of the above test instruments is 12 months and the calibrations are traceable to NML/ROC and NIST/USA.

4.6.3 TEST PROCEDURES

1. Check the calibration of the measuring instrument using either an internal calibrator or a known signal from an external generator.
2. Turn on the EUT and connect it to measurement instrument. Then set it to any one convenient frequency within its operating range.
3. By using the MaxHold function record the separation of two adjacent channels.
4. Measure the frequency difference of these two adjacent channels by SA MARK function. And then plot the result on SA screen.
5. Repeat above procedures until all frequencies measured were complete.



4.6.4 DEVIATION FROM TEST STANDARD

No deviation.

4.6.5 TEST SETUP



4.6.6 TEST RESULTS

EUT	BLUETOOTH WIRELESS MOUSE	MODEL	VGP-BMS30
MODULATION TYPE	GFSK	ENVIRONMENTAL CONDITIONS	27deg. C, 70%RH, 998hPa
INPUT POWER	3Vdc	TESTED BY	Jamison Chan

Channel	Frequency (MHz)	ADJACENT CHANNEL SEPARATION (MHz)	Minimum Limit (MHz)	Pass / Fail
0	2402	1.020	0.975	PASS
39	2441	1.005	0.966	PASS
78	2480	1.000	0.966	PASS

The minimum limit is 20dB bandwidth. Test results please refer to next two pages.



CH 0

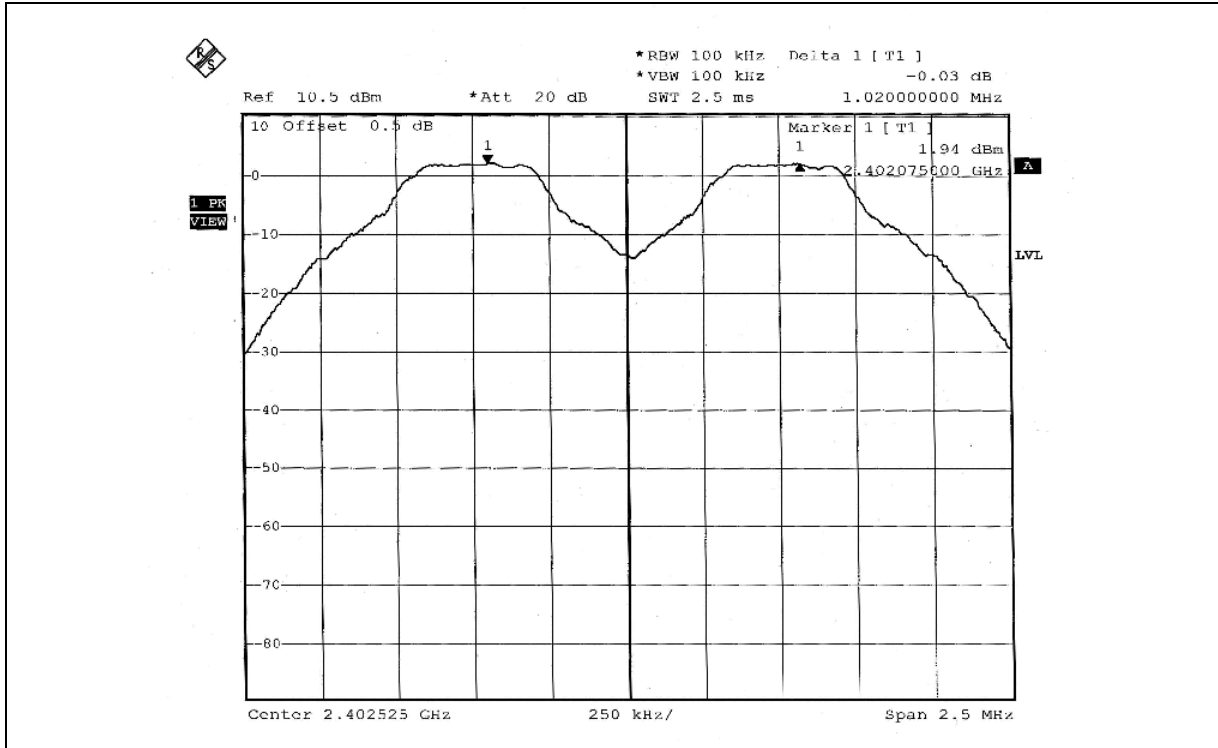

CH 39

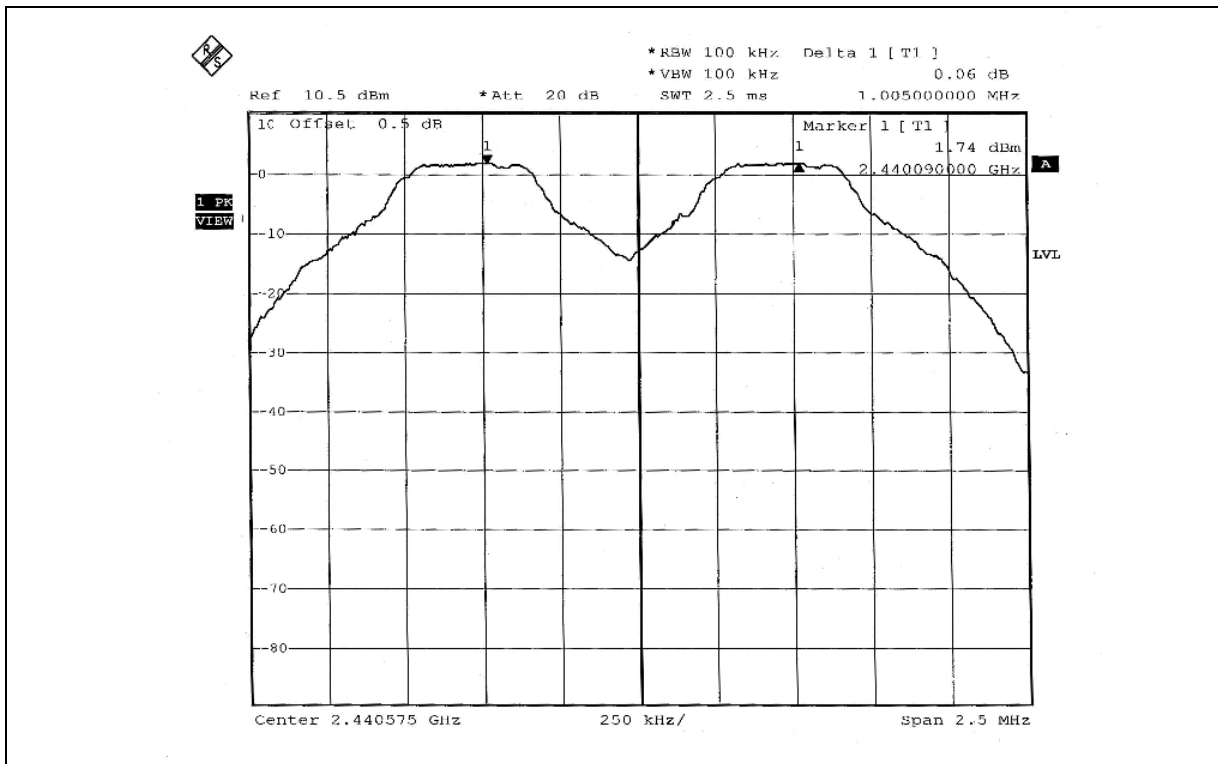



CH 78

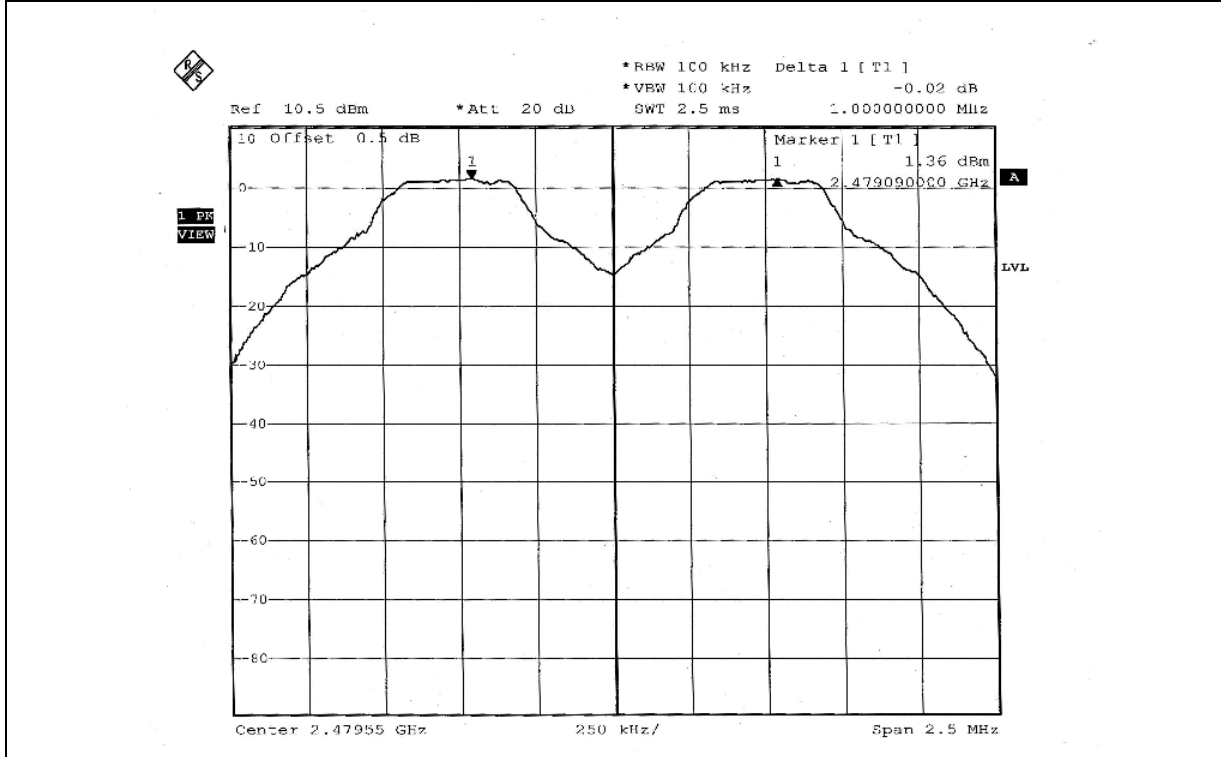



4.7 MAXIMUM PEAK OUTPUT POWER

4.7.1 LIMITS OF MAXIMUM PEAK OUTPUT POWER MEASUREMENT

The Maximum Peak Output Power Measurement is 30dBm.

4.7.2 TEST INSTRUMENTS

Description & Manufacturer	Model No.	Serial No.	Calibrated Until
SPECTRUM ANALYZER	FSP 40	100036	Mar 20. 2006

NOTE: The calibration interval of the above test instruments is 12 months and the calibrations are traceable to NML/ROC and NIST/USA.

4.7.3 TEST PROCEDURES

- a. Check the calibration of the measuring instrument using either an internal calibrator or a known signal from an external generator.
- b. Turn on the EUT and connect it to measurement instrument. Then set it to any one convenient frequency within its operating range. Set a reference level on the measuring instrument equal to the highest peak value.
- c. The center frequency of the spectrum analyzer is set to the fundamental frequency and using 1 MHz RBW and 3 MHz VBW.
- d. Measure the captured power within the band and recording the plot.
- e. Repeat above procedures until all frequencies required were complete.

4.7.4 DEVIATION FROM TEST STANDARD

No deviation

4.7.5 TEST SETUP



For the actual test configuration, please refer to the related Item – Photographs of the Test Configuration.

4.7.6 EUT OPERATING CONDITION

The software provided by client enabled the EUT to transmit and receive data at lowest, middle and highest channel frequencies individually.

4.7.7 TEST RESULTS

EUT	BLUETOOTH WIRELESS MOUSE	MODEL	VGP-BMS30
MODULATION TYPE	GFSK	ENVIRONMENTAL CONDITIONS	27deg. C, 70%RH, 998hPa
INPUT POWER	3Vdc	TESTED BY	Jamison Chan

CHANNEL	CHANNEL FREQUENCY (MHz)	PEAK POWER OUTPUT (mW)	PEAK POWER OUTPUT (dBm)	PEAK POWER LIMIT (dBm)	PASS/FAIL
0	2402	1.879	2.74	30	PASS
39	2441	1.820	2.60	30	PASS
78	2480	1.675	2.24	30	PASS



CH 0

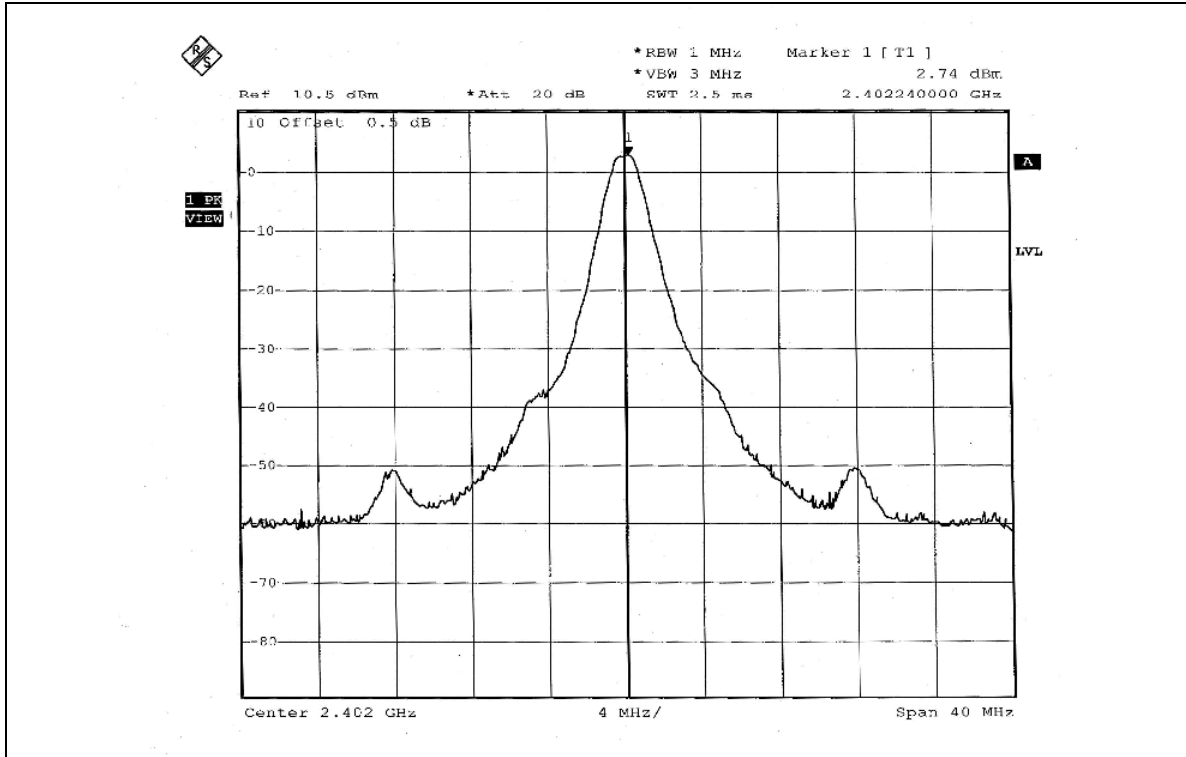

CH 39

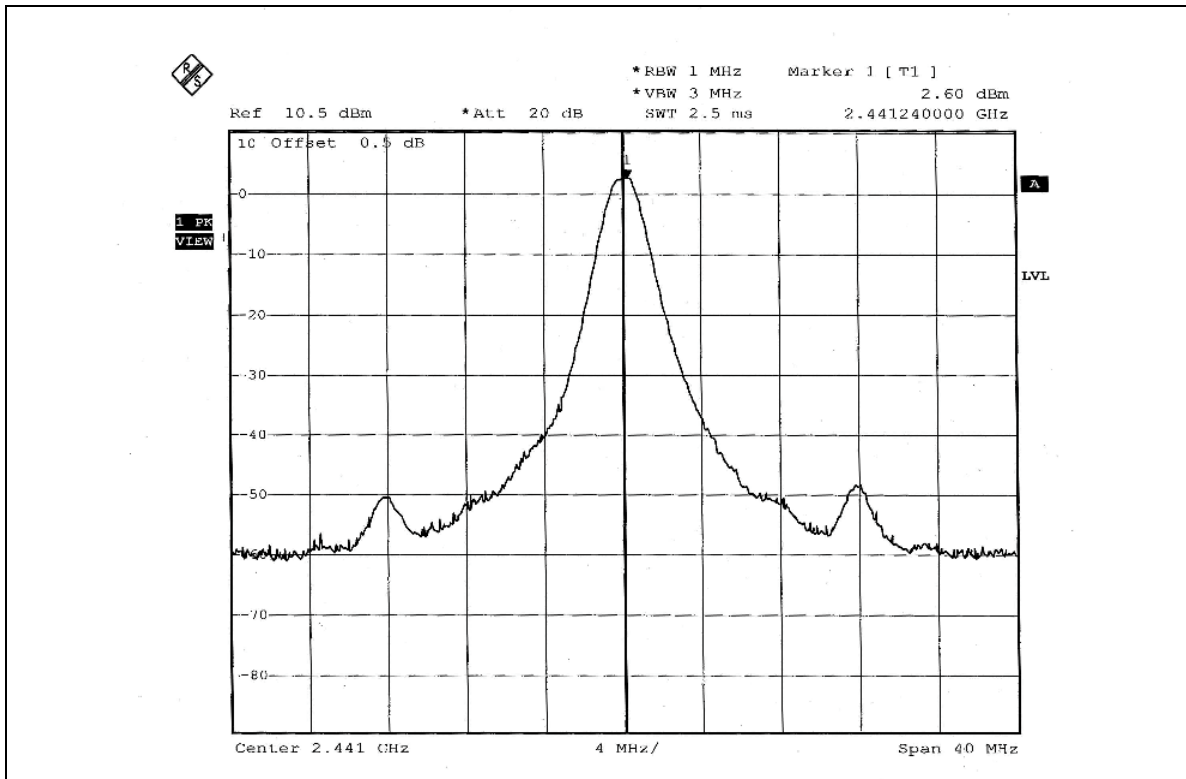



CH 78

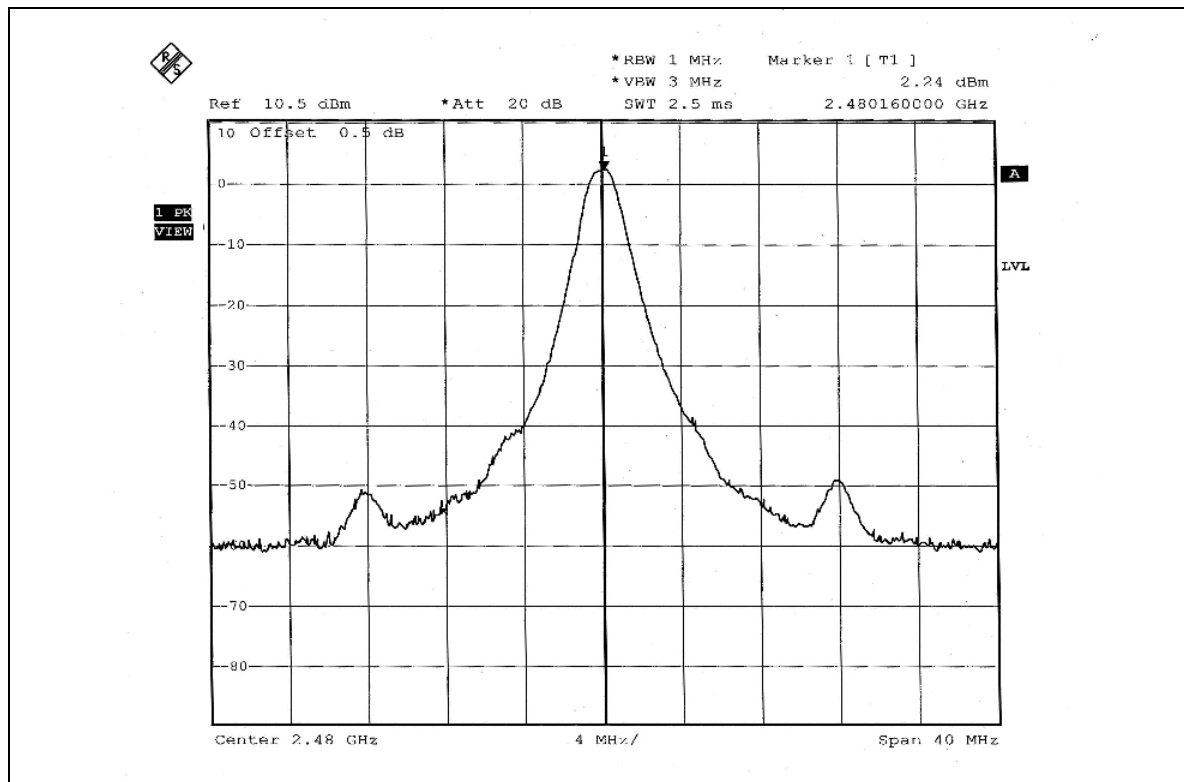



4.8 BAND EDGES MEASUREMENT

4.8.1 LIMITS OF BAND EDGES MEASUREMENT

Below -20dB of the highest emission level of operating band (in 100KHz RBW).

4.8.2 TEST INSTRUMENTS

Description & Manufacturer	Model No.	Serial No.	Calibrated Until
SPECTRUM ANALYZER	FSP 40	100036	Mar 20. 2006

NOTE: The calibration interval of the above test instruments is 12 months and the calibrations are traceable to NML/ROC and NIST/USA.

4.8.3 TEST PROCEDURE

The transmitter output was connected to the spectrum analyzer via a low lose cable. Set both RBW and VBW of spectrum analyzer to 100 kHz with suitable frequency span including 100 MHz bandwidth from band edge. The band edges was measured and recorded.

4.8.4 DEVIATION FROM TEST STANDARD

No deviation.

4.8.5 EUT OPERATING CONDITION

The software provided by client enabled the EUT to transmit and receive data at lowest, middle and highest channel frequencies individually.



4.8.6 TEST RESULTS

The spectrum plots are attached on the following 4 images. D1 line indicates the highest level, D2 line indicates the 20dB offset below D1. It shows compliance with the requirement in part 15.247(d).

NOTE 1:

The band edge emission plot on page 42 shows 51.91dBc between carrier maximum power and local maximum emission in restrict band (2.3542GHz). The emission of carrier strength list in the test result of channel 0 at the item 4.2.7 is 91.54dBuV/m (Peak), so the maximum field strength in restrict band is $91.54 - 51.91 = 39.63$ dBuV/m, which is under 74 dBuV/m limit.

The band edge emission plot on page 42 shows 51.91dBc between carrier maximum power and local maximum emission in restrict band (2.3542GHz). The emission of carrier strength list in the test result of channel 0 at the item 4.2.7 is 57.04dBuV/m (Average), so the maximum field strength in restrict band is $57.04 - 51.91 = 5.13$ dBuV/m, which is under 54 dBuV/m limit.

NOTE 2:

The band edge emission plot on page 43 shows 47.64dBc between carrier maximum power and local maximum emission in restrict band (2.4835GHz). The emission of carrier strength list in the test result of channel 78 at the item 4.2.7 is 93.86dBuV/m (Peak), so the maximum field strength in restrict band is $93.86 - 47.64 = 46.22$ dBuV/m, which is under 74 dBuV/m limit.

The band edge emission plot on page 43 shows 47.64dBc between carrier maximum power and local maximum emission in restrict band (2.4835GHz). The emission of carrier strength list in the test result of channel 78 at the item 4.2.7 is 59.36dBuV/m (Average), so the maximum field strength in restrict band is $59.36 - 47.64 = 11.72$ dBuV/m, which is under 54 dBuV/m limit.

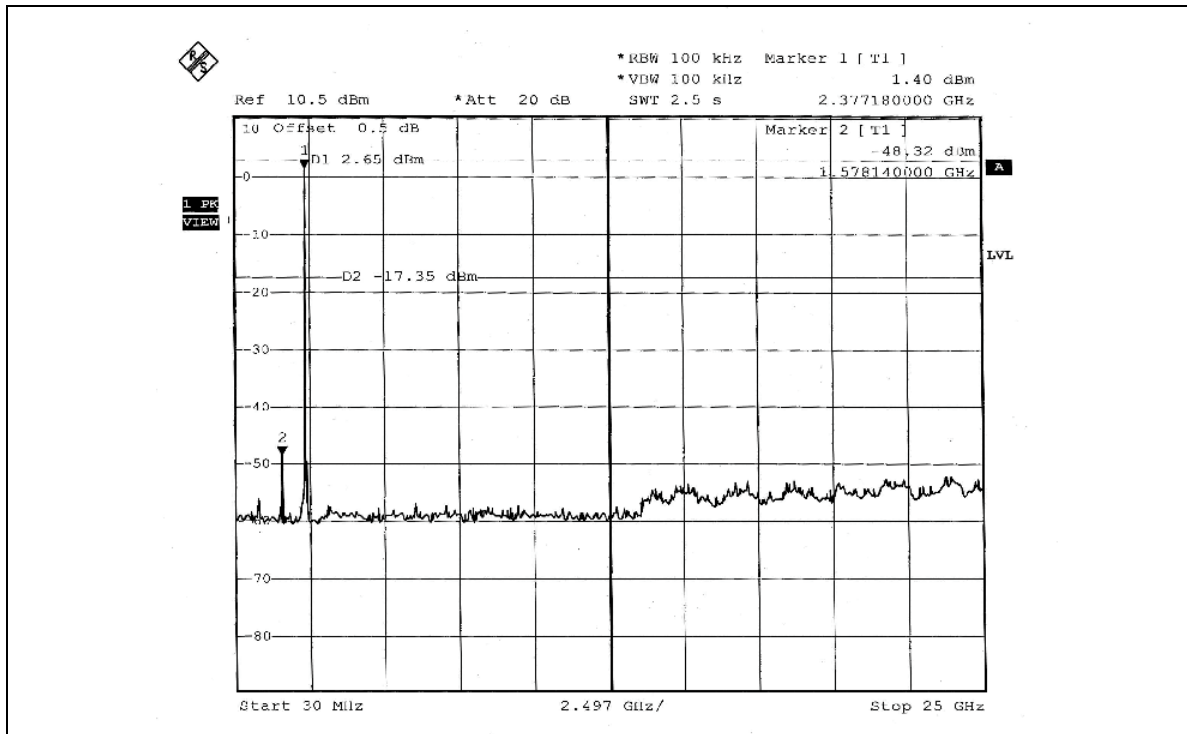
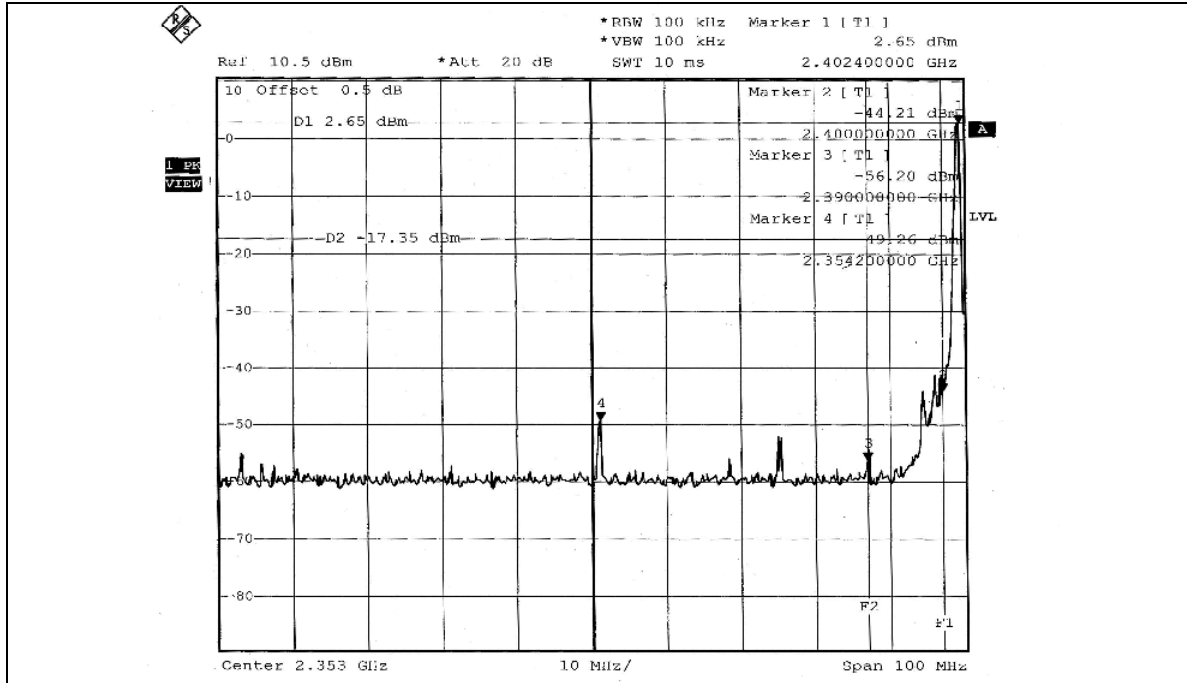

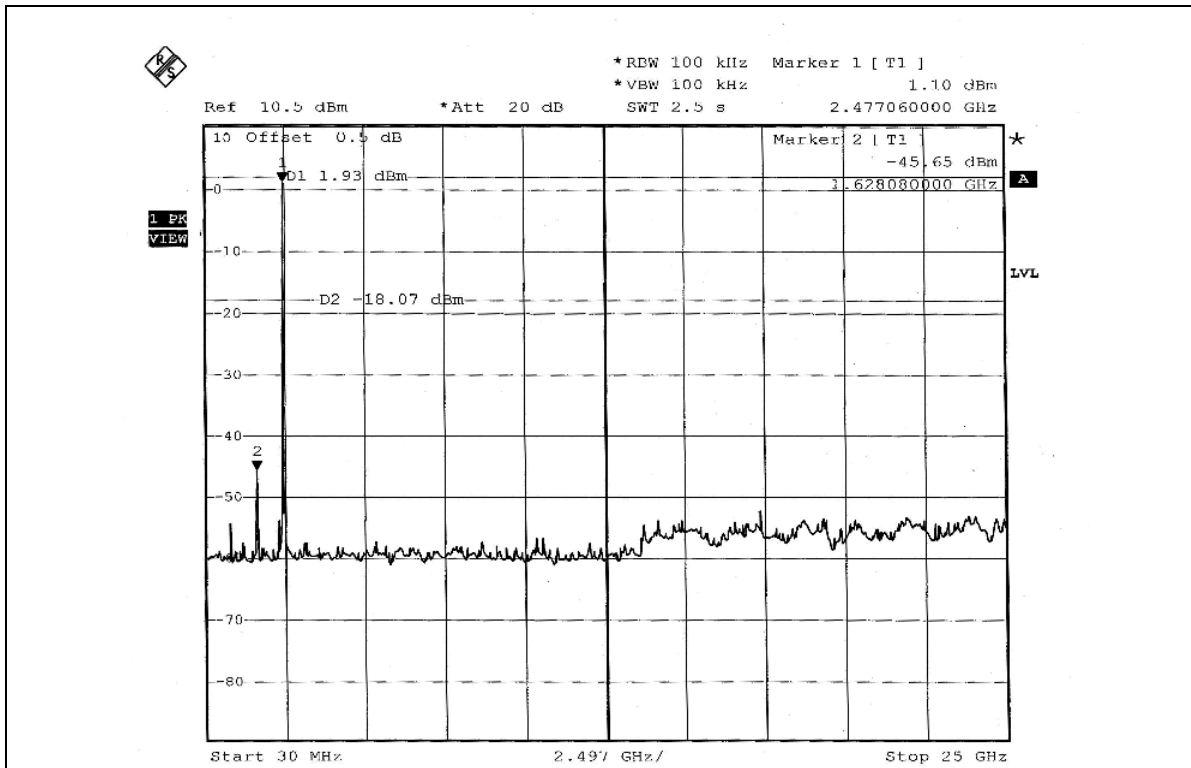
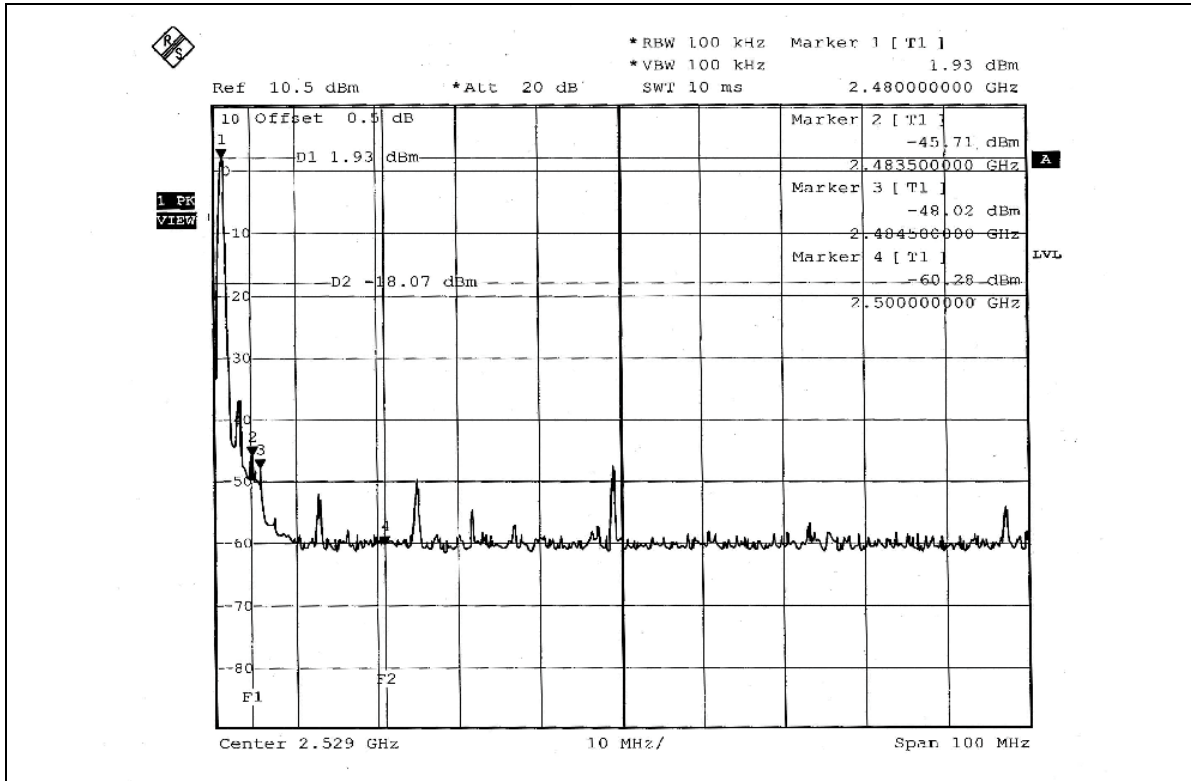



4.9 ANTENNA REQUIREMENT

4.9.1 STANDARD APPLICABLE

For intentional device, according to FCC 47 CFR Section 15.203, an intentional radiator shall be designed to ensure that no antenna other than that furnished by the responsible party shall be used with the device.

And according to FCC 47 CFR Section 15.247 (b), if transmitting antennas of directional gain greater than 6 dBi are used, the power shall be reduced by the amount in dB that the directional gain of the antenna exceeds 6 dBi.

4.9.2 ANTENNA CONNECTED CONSTRUCTION

The antenna used in this product is Inverted-F antenna without connector, and the maximum gain of this antenna is -3.04dBi .

5. PHOTOGRAPHS OF THE TEST CONFIGURATION

RADIATED EMISSION TEST

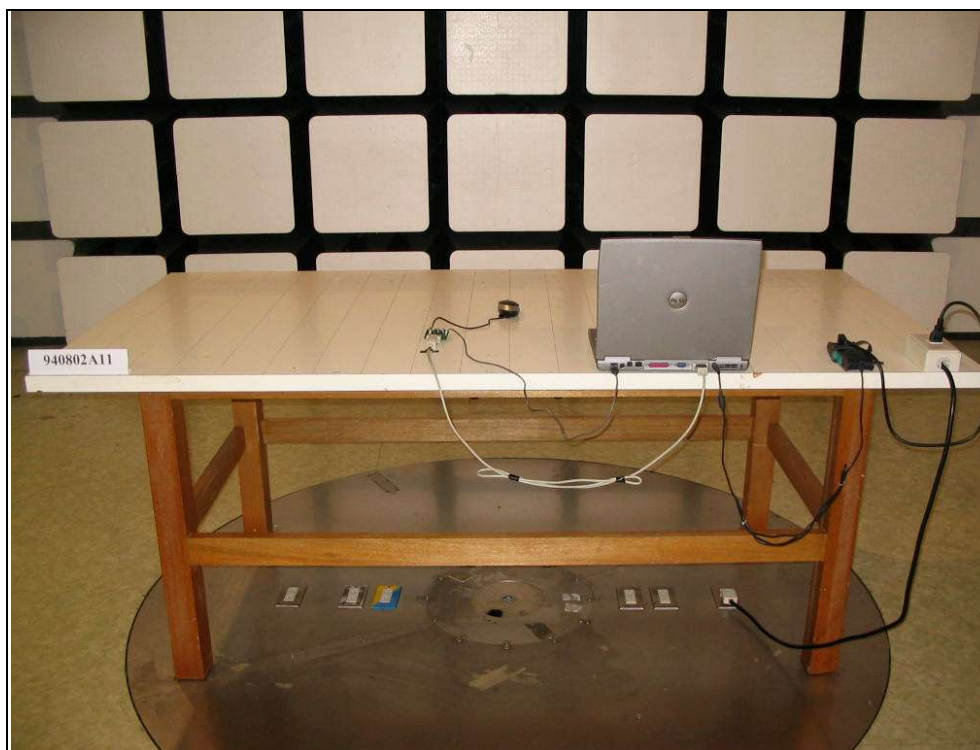



6. INFORMATION ON THE TESTING LABORATORIES

We, ADT Corp., were founded in 1988 to provide our best service in EMC, Radio, Telecom and Safety consultation. Our laboratories are accredited and approved by the following approval agencies according to ISO/IEC 17025.

USA	FCC, NVLAP, UL, A2LA
Germany	TUV Rheinland
Japan	VCCI
Norway	NEMKO
Canada	INDUSTRY CANADA , CSA
R.O.C.	CNLA, BSMI, DGT
Netherlands	Telefication
Singapore	PSB , GOST-ASIA(MOU)
Russia	CERTIS(MOU)

Copies of accreditation certificates of our laboratories obtained from approval agencies can be downloaded from our web site:

www.adt.com.tw/index.5/phtml. If you have any comments, please feel free to contact us at the following:

Linko EMC/RF Lab:

Tel: 886-2-26052180

Fax: 886-2-26052943

Hsin Chu EMC/RF Lab:

Tel: 886-3-5935343

Fax: 886-3-5935342

Hwa Ya EMC/RF/Safety Telecom Lab:

Tel: 886-3-3183232

Fax: 886-3-3185050

Linko RF Lab.

Tel: 886-3-3270910

Fax: 886-3-3270892

Web Site: www.adt.com.tw

The address and road map of all our labs can be found in our web site also.