

FCC TEST REPORT

REPORT NO.: RF950526A05
TYPE/MODEL: PHS-5/, HS-68W/BH-203,
HS-84W/BH-204, HS-88W/BH-205
VERSION: HW:0.4 SW:1.2 MV:0.4 DVT1.1
RECEIVED: July 1, 2006
TESTED: July 7 ~ 27, 2006
ISSUED: Aug. 1, 2006

APPLICANT: PRIMAX ELECTRONICS LTD.

ADDRESS: No. 669, Ruey Kuang Road, Neihu, Taipei, Taiwan,
R.O.C.

ISSUED BY: Advance Data Technology Corporation

LAB LOCATION: No. 47, 14th Ling, Chia Pau Tsuen, Lin Kou Hsiang
244, Taipei Hsien, Taiwan, R.O.C.

This test report consists of 94 pages in total. It may be duplicated completely for legal use with the approval of the applicant. It should not be reproduced except in full, without the written approval of our laboratory. The client should not use it to claim product endorsement by CNLA, A2LA or any government agencies. The test results in the report only apply to the tested sample.





TABLE OF CONTENTS

1.	CERTIFICATION	4
2.	SUMMARY OF TEST RESULTS.....	5
2.1	MEASUREMENT UNCERTAINTY	6
3.	GENERAL INFORMATION.....	7
3.1	GENERAL DESCRIPTION OF EUT.....	7
3.2	DESCRIPTION OF TEST MODES.....	9
3.2.1	CONFIGURATION OF SYSTEM UNDER TEST	10
3.2.2	TEST MODE APPLICABILITY AND TESTED CHANNEL DETAIL	11
3.3.3	GENERAL DESCRIPTION OF APPLIED STANDARDS	12
3.3.4	DESCRIPTION OF SUPPORT UNITS.....	12
4.	TEST TYPES AND RESULTS	13
4.1	CONDUCTED EMISSION MEASUREMENT	13
4.1.1	LIMITS OF CONDUCTED EMISSION MEASUREMENT.....	13
4.1.2	TEST INSTRUMENTS	13
4.1.3	TEST PROCEDURES.....	14
4.1.4	DEVIATION FROM TEST STANDARD	14
4.1.5	TEST SETUP	15
4.1.6	EUT OPERATING CONDITIONS.....	15
4.1.7	TEST RESULTS.....	16
4.2	RADIATED EMISSION MEASUREMENT	40
4.2.1	LIMITS OF RADIATED EMISSION MEASUREMENT.....	40
4.2.2	TEST INSTRUMENTS	41
4.2.3	TEST PROCEDURES.....	42
4.2.4	DEVIATION FROM TEST STANDARD	42
4.2.5	TEST SETUP	43
4.2.6	EUT OPERATING CONDITIONS.....	43
4.2.7	TEST RESULTS.....	44
4.3	NUMBER OF HOPPING FREQUENCY USED	54
4.3.1	LIMIT OF HOPPING FREQUENCY USED	54
4.3.2	TEST INSTRUMENTS	54
4.3.3	TEST PROCEDURES.....	54
4.3.4	DEVIATION FROM TEST STANDARD	55
4.3.5	TEST SETUP	55
4.3.6	TEST RESULTS.....	55
4.4	DWELL TIME ON EACH CHANNEL	58
4.4.1	LIMIT OF DWELL TIME USED	58
4.4.2	TEST INSTRUMENTS	58
4.4.3	TEST PROCEDURES.....	58
4.4.4	DEVIATION FROM TEST STANDARD	58
4.4.5	TEST SETUP	59
4.4.6	TEST RESULTS.....	59
4.5	CHANNEL BANDWIDTH	67
4.5.1	LIMITS OF CHANNEL BANDWIDTH.....	67
4.5.2	TEST INSTRUMENTS	67



4.5.3	TEST PROCEDURE	67
4.5.4	DEVIATION FROM TEST STANDARD	68
4.5.5	TEST SETUP	68
4.5.6	EUT OPERATING CONDITION	68
4.5.7	TEST RESULTS	69
4.6	HOPPING CHANNEL SEPARATION	73
4.6.1	LIMIT OF HOPPING CHANNEL SEPARATION	73
4.6.2	TEST INSTRUMENTS	73
4.6.3	TEST PROCEDURES	73
4.6.4	DEVIATION FROM TEST STANDARD	74
4.6.5	TEST SETUP	74
4.6.6	TEST RESULTS	75
4.7	MAXIMUM PEAK OUTPUT POWER	79
4.7.1	LIMITS OF MAXIMUM PEAK OUTPUT POWER MEASUREMENT	79
4.7.2	TEST INSTRUMENTS	79
4.7.3	TEST PROCEDURES	79
4.7.4	DEVIATION FROM TEST STANDARD	79
4.7.5	TEST SETUP	80
4.7.6	EUT OPERATING CONDITION	80
4.7.7	TEST RESULTS	81
4.8	BAND EDGES MEASUREMENT	85
4.8.1	LIMITS OF BAND EDGES MEASUREMENT	85
4.8.2	TEST INSTRUMENTS	85
4.8.3	TEST PROCEDURE	85
4.8.4	DEVIATION FROM TEST STANDARD	85
4.8.5	EUT OPERATING CONDITION	85
4.8.6	TEST RESULTS	86
4.9	ANTENNA REQUIREMENT	92
4.9.1	STANDARD APPLICABLE	92
4.9.2	ANTENNA CONNECTED CONSTRUCTION	92
5.	INFORMATION ON THE TESTING LABORATORIES	93
	APPENDIX-A	A-1



1. CERTIFICATION

PRODUCT: Bluetooth Headset
TYPE/MODEL: PHS-5/ (**Brand:** PRIMAX)
HS-68W/BH-203, HS-84W/BH-204, HS-88W/BH-205
(**Brand:** NOKIA)
APPLICANT: PRIMAX ELECTRONICS LTD.
TESTED: July 7 ~ 27, 2006
TEST SAMPLE: ENGINEERING SAMPLE
STANDARDS: FCC Part 15, Subpart C (Section 15.247),
ANSI C63.4-2003

The above equipment (Type/Model: PHS-5/, HS-84W/BH-204) have been tested by **Advance Data Technology Corporation**, and found compliance with the requirement of the above standards. The test record, data evaluation & Equipment Under Test (EUT) configurations represented herein are true and accurate accounts of the measurements of the sample's EMC characteristics under the conditions specified in this report.

PREPARED BY : Annie Chang , **DATE:** Aug. 1, 2006
(Annie Chang)

TECHNICAL ACCEPTANCE : Ken Liu , **DATE:** Aug. 1, 2006
Responsible for RF (Ken Liu)

APPROVED BY : Gary Chang , **DATE:** Aug. 1, 2006
(Gary Chang / Supervisor)

2. SUMMARY OF TEST RESULTS

The EUT has been tested according to the following specifications:

APPLIED STANDARD: FCC Part 15, Subpart C			
STANDARD SECTION	TEST TYPE AND LIMIT	RESULT	REMARK
15.207	AC Power Conducted Emission	PASS	Meet the requirement of limit. Minimum passing margin is -9.77dB at 0.494MHz.
15.247(a)(1)(iii)	Number of Hopping Frequency Used Spec.: At least 15 channels	PASS	Meet the requirement of limit.
15.247(a)(1)(iii)	Dwell Time on Each Channel Spec. : Max. 0.4 second within 31.6 second	PASS	Meet the requirement of limit.
15.247(a)(1)	1. Hopping Channel Separation Spec. : Min. 25 kHz or 20 dB bandwidth, whichever is greater (see Note 1) 2. Spectrum Bandwidth of a Frequency Hopping Sequence Spread Spectrum System	PASS	Meet the requirement of limit.
15.247(b)	Maximum Peak Output Power Spec.: max. 30dBm (see Note 1)	PASS	Meet the requirement of limit.
15.247(d)	Transmitter Radiated Emissions Spec.: Table 15.209	PASS	Meet the requirement of limit. Minimum passing margin is -5.44 dB at 2483.50MHz.
15.247(d)	Band Edge Measurement	PASS	Meet the requirement of limit.

NOTE: If The Frequency Hopping System operating in 2400-2483.5MHz band and the output power less than 125mW. The hopping channel carrier frequencies separated by a minimum of 25kHz or two-thirds of the 20dB bandwidth of hopping channel whichever is greater.

2.1 MEASUREMENT UNCERTAINTY

Where relevant, the following measurement uncertainty levels have been estimated for tests performed on the EUT as specified in CISPR 16-4:

This uncertainty represents an expanded uncertainty expressed at approximately the 95% confidence level using a coverage factor of $k=2$.

MEASUREMENT	UNCERTAINTY
Conducted emissions	2.45 dB
Radiated emissions	3.55 dB

3. GENERAL INFORMATION

3.1 GENERAL DESCRIPTION OF EUT

PRODUCT	Bluetooth Headset
TYPE/MODEL	PHS-5/, HS-68W/BH-203, HS-84W/BH-204, HS-88W/BH-205
FCC ID	EMJB81106
POWER SUPPLY	3.7Vdc from battery, 5.7Vdc / 6V from adapter
MODULATION TYPE	GFSK, π /4-DQPSK, 8DPSK
RADIO TECHNOLOGY	FHSS
TRANSFER RATE	1/2/3Mbps
FREQUENCY RANGE	2402 MHz ~ 2480 MHz
NUMBER OF CHANNEL	79
OUTPUT POWER	2.099mW
ANTENNA TYPE	Printed antenna with 0dBi gain
DATA CABLE	NA
I/O PORTS	NA
ASSOCIATED DEVICES	NA

NOTE:

- The EUT is a Headset, with Bluetooth technology.
- The EUT has following types/models:

Brand	Type/Model	Differentiation
PRIMAX	PHS-5/	Differentiation of outer appearance
NOKIA	HS-68W/BH-203	
	HS-84W/BH-204	
	HS-88W/BH-205	

For the test, type/model: **PHS-5/, HS-84W/BH-204** were selected as the representative models and their data were recorded in this report.

3. The EUT was power supplied from the following power adapters:

For PHS-5/:

Brand	LEI
Model	MU03-5060055-A1
AC I/P Rating	100-240V, 0.15A,50-60Hz
DC O/P Rating	6V, 550mA

For HS-68W/BH-203, HS-84W/BH-204, HS-88W/BH-205:

Brand	NOKIA
Model	ACP-12C
AC I/P Rating	100-240V, 125mA,50-60Hz
DC O/P Rating	5.7V, 800mA

4. The above EUT information was declared by the manufacturer and for more detailed features description, please refer to the manufacturer's specifications or User's Manual.

3.2 DESCRIPTION OF TEST MODES

79 channels are provided to this EUT:

CHANNEL	FREQ. (MHz)	CHANNEL	FREQ. (MHz)	CHANNEL	FREQ. (MHz)	CHANNEL	FREQ. (MHz)
0	2402	20	2422	40	2442	60	2462
1	2403	21	2423	41	2443	61	2463
2	2404	22	2424	42	2444	62	2464
3	2405	23	2425	43	2445	63	2465
4	2406	24	2426	44	2446	64	2466
5	2407	25	2427	45	2447	65	2467
6	2408	26	2428	46	2448	66	2468
7	2409	27	2429	47	2449	67	2469
8	2410	28	2430	48	2450	68	2470
9	2411	29	2431	49	2451	69	2471
10	2412	30	2431	50	2452	70	2472
11	2413	31	2433	51	2453	71	2473
12	2414	32	2434	52	2454	72	2474
13	2415	33	2435	53	2455	73	2475
14	2416	34	2436	54	2456	74	2476
15	2417	35	2437	55	2457	75	2477
16	2418	36	2438	56	2458	76	2478
17	2419	37	2439	57	2459	77	2479
18	2420	38	2440	58	2460	78	2480
19	2421	39	2441	59	2461		

3.2.1 CONFIGURATION OF SYSTEM UNDER TEST

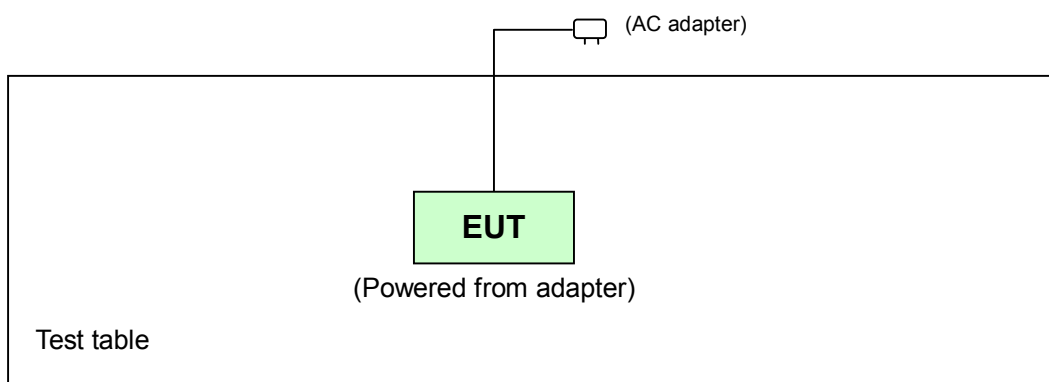

3.2.2 TEST MODE APPLICABILITY AND TESTED CHANNEL DETAIL

EUT CONFIGURE MODE	Applicable to				Description
	PLC	RE<1G	RE≥1G	APCM	
A	√	√	√	√	Type/Model: PHS-5/ with LEI adapter (powered from adapter)
B	√	√	-	-	Type/Model: HS-84W/BH-204 with NOKIA adapter (powered from adapter)

Where **PLC**: Power Line Conducted Emission

RE<1G: Radiated Emission below 1GHz

RE≥1G: Radiated Emission above 1GHz

APCM: Antenna Port Conducted Measurement

POWER LINE CONDUCTED EMISSION TEST:

- Pre-Scan has been conducted to determine the worst-case mode from all possible combinations between available modulations and packet types.
- Following channel(s) was (were) selected for the final test as listed below.

EUT CONFIGURE MODE	AVAILABLE CHANNEL	TESTED CHANNEL	MODULATION TECHNOLOGY	MODULATION TYPE	PACKET TYPE	DATE RATE
A	0 to 78	0, 39, 78	FHSS	GFSK	DH5	1
A	0 to 78	0, 39, 78	FHSS	8DPSK	DH5	3
B	0 to 78	0, 39, 78	FHSS	GFSK	DH5	1
B	0 to 78	0, 39, 78	FHSS	8DPSK	DH5	3

RADIATED EMISSION TEST (BELOW 1 GHz):

- Pre-Scan has been conducted to determine the worst-case mode from all possible combinations between available modulations, packet types and X, Y, Z Axis.
- Following channel(s) was (were) selected for the final test as listed below.

EUT CONFIGURE MODE	AVAILABLE CHANNEL	TESTED CHANNEL	MODULATION TECHNOLOGY	MODULATION TYPE	PACKET TYPE	DATE RATE	AXIS
A	0 to 78	78	FHSS	GFSK	DH5	1	X
A	0 to 78	78	FHSS	8DPSK	DH5	3	X
B	0 to 78	78	FHSS	GFSK	DH5	1	X
B	0 to 78	78	FHSS	8DPSK	DH5	3	X

RADIATED EMISSION TEST (ABOVE 1 GHz):

- Pre-Scan has been conducted to determine the worst-case mode from all possible combinations between available modulations, packet types and X, Y, Z Axis.
- Following channel(s) was (were) selected for the final test as listed below.

EUT CONFIGURE MODE	AVAILABLE CHANNEL	TESTED CHANNEL	MODULATION TECHNOLOGY	MODULATION TYPE	PACKET TYPE	DATE RATE	AXIS
A	0 to 78	0, 39, 78	FHSS	GFSK	DH5	1	X
A	0 to 78	0, 39, 78	FHSS	8DPSK	DH5	3	X

BANDEDGE MEASUREMENT:

- Pre-Scan has been conducted to determine the worst-case mode from all possible combinations between available modulations and packet types.
- Following channel(s) was (were) selected for the final test as listed below.

EUT CONFIGURE MODE	AVAILABLE CHANNEL	TESTED CHANNEL	MODULATION TECHNOLOGY	MODULATION TYPE	PACKET TYPE	DATE RATE
A	0 to 78	0, 78	FHSS	GFSK	DH5	1
A	0 to 78	0, 78	FHSS	8DPSK	DH5	3

ANTENNA PORT CONDUCTED MEASUREMENT:

- Pre-Scan has been conducted to determine the worst-case mode from all possible combinations between available modulations and packet types.
- Following channel(s) was (were) selected for the final test as listed below.

EUT CONFIGURE MODE	AVAILABLE CHANNEL	TESTED CHANNEL	MODULATION TECHNOLOGY	MODULATION TYPE	PACKET TYPE	DATE RATE
A	0 to 78	0, 39, 78	FHSS	GFSK	DH5	1
A	0 to 78	0, 39, 78	FHSS	8DPSK	DH5	3

3.3.3 GENERAL DESCRIPTION OF APPLIED STANDARDS

The EUT is a RF product. According to the specifications of the manufacturer, it must comply with the requirements of the following standards:

FCC Part 15, Subpart C. (15.247)

ANSI C63.4- 2003

All test items have been performed and recorded as per the above standards.

3.3.4 DESCRIPTION OF SUPPORT UNITS

The EUT has been tested as an independent unit together with its power adapter.

4. TEST TYPES AND RESULTS

4.1 CONDUCTED EMISSION MEASUREMENT

4.1.1 LIMITS OF CONDUCTED EMISSION MEASUREMENT

FREQUENCY OF EMISSION (MHz)	CONDUCTED LIMIT (dB μ V)	
	Quasi-peak	Average
0.15 ~ 0.5	66 to 56	56 to 46
0.5 ~ 5	56	46
5 ~ 30	60	50

- NOTE:**
1. The lower limit shall apply at the transition frequencies.
 2. The limit decreases in line with the logarithm of the frequency in the range of 0.15 to 0.50 MHz.
 3. All emanations from a class A/B digital device or system, including any network of conductors and apparatus connected thereto, shall not exceed the level of field strengths specified above.

4.1.2 TEST INSTRUMENTS

DESCRIPTION & MANUFACTURER	MODEL NO.	SERIAL NO.	CALIBRATED UNTIL
ROHDE & SCHWARZ Test Receiver	ESHS 30	828765/002	Jul. 10, 2007
ROHDE & SCHWARZ Artificial Mains Network (for EUT)	ESH3-Z5	835239/001	Mar. 08, 2007
LISN With Adapter (for EUT)	AD10	C09Ada-001	Mar. 08, 2007
ROHDE & SCHWARZ Artificial Mains Network (for peripherals)	ESH3-Z5	835239/002	Mar. 20, 2007
ROHDE & SCHWARZ 4-wire ISN	ENY41	835154/007	Apr. 02, 2007
ROHDE & SCHWARZ 2-wire ISN	ENY22	833823/026	Apr. 02, 2007
Software	ADT_Cond_V7.3.2	NA	NA
Software	ADT_ISN_V7.3.2	NA	NA
RF cable (JYEBAO)	5D-FB	Cable-C09.01	Mar. 30, 2007
SUHNER Terminator (For ROHDE & SCHWARZ LISN)	65BNC-5001	E1-010789	May 21, 2007

- NOTE:**
1. The calibration interval of the above test instruments is 12 months and the calibrations are traceable to NML/ROC and NIST/USA.
 2. The test was performed in ADT Shielded Room No. 9.
 3. The VCCI Site Registration No. C-1312.

4.1.3 TEST PROCEDURES

- a. The EUT was placed 0.4 meters from the conducting wall of the shielded room with EUT being connected to the power mains through a line impedance stabilization network (LISN). Other support units were connected to the power mains through another LISN. The two LISNs provide 50 ohm/ 50uH of coupling impedance for the measuring instrument.
- b. Both lines of the power mains connected to the EUT were checked for maximum conducted interference.
- c. The frequency range from 150kHz to 30MHz was searched. Emission levels under (Limit - 20dB) was not recorded.

4.1.4 DEVIATION FROM TEST STANDARD

No deviation

4.1.5 TEST SETUP

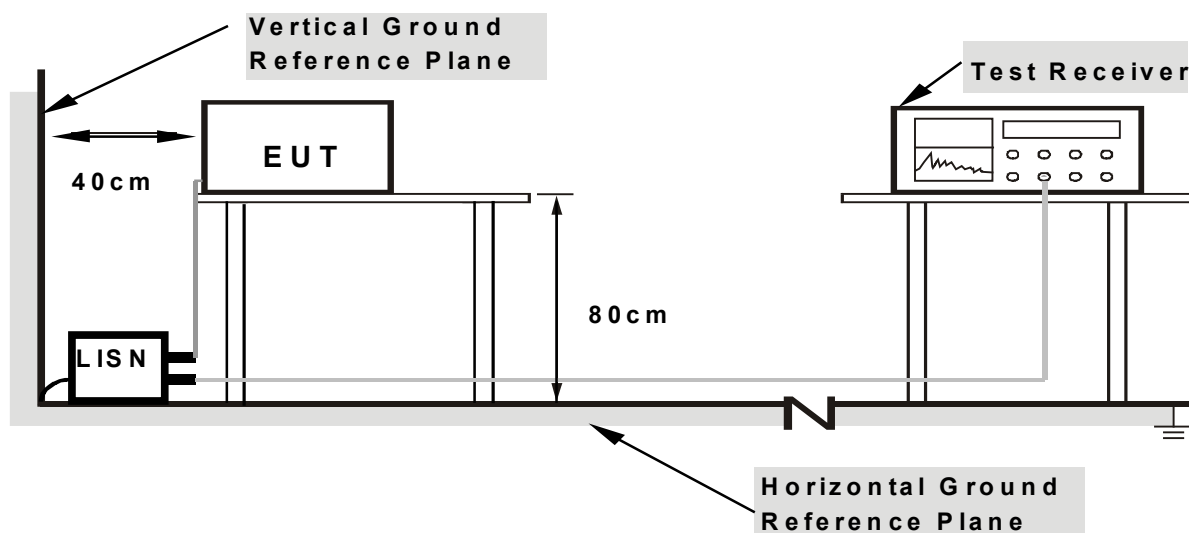

- Note:**
1. Support units were connected to second LISN.
 2. Both of LISNs (AMN) are 80 cm from EUT and at least 80 cm from other units and other metal planes support units.

For the actual test configuration, please refer to the related item – Photographs of the Test Configuration.

4.1.6 EUT OPERATING CONDITIONS

Set the EUT under transmission/receiving condition continuously at specific channel frequency.

4.1.7 TEST RESULTS

CONDUCTED WORST CASE DATA: MODE A FOR GFSK

TEST MODE	A		
MODULATION TYPE	GFSK	CHANNEL	0
INPUT POWER	120Vac, 60 Hz	6dB BANDWIDTH	9 kHz
ENVIRONMENTAL CONDITIONS	27deg. C, 77%RH, 996hPa	PHASE	Line 1
TESTED BY	Jamison Chan		

No	Freq. [MHz]	Corr. Factor (dB)	Reading Value		Emission Level		Limit		Margin	
			[dB (uV)]		[dB (uV)]		[dB (uV)]		(dB)	
			Q.P.	AV.	Q.P.	AV.	Q.P.	AV.	Q.P.	AV.
1	0.252	0.20	41.11	-	41.31	-	61.71	51.71	-20.40	-
2	0.373	0.20	36.31	-	36.51	-	58.44	48.44	-21.93	-
3	0.486	0.20	45.28	-	45.48	-	56.24	46.24	-10.76	-
4	0.990	0.20	36.72	-	36.92	-	56.00	46.00	-19.08	-
5	2.188	0.31	39.15	-	39.46	-	56.00	46.00	-16.54	-
6	28.641	1.37	22.27	-	23.64	-	60.00	50.00	-36.36	-

- REMARKS:**
1. Q.P. and AV. are abbreviations of quasi-peak and average individually.
 2. "-": The Quasi-peak reading value also meets average limit and measurement with the average detector is unnecessary.
 3. The emission levels of other frequencies were very low against the limit.
 4. Margin value = Emission level - Limit value
 5. Correction factor = Insertion loss + Cable loss
 6. Emission Level = Correction Factor + Reading Value.

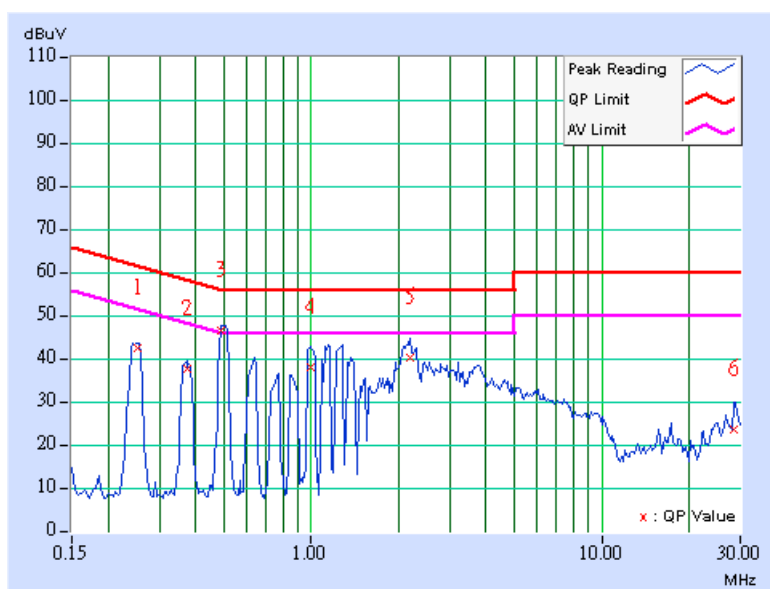

TEST MODE	A		
MODULATION TYPE	GFSK	CHANNEL	0
INPUT POWER	120Vac, 60 Hz	6dB BANDWIDTH	9 kHz
ENVIRONMENTAL CONDITIONS	27deg. C, 77%RH, 996hPa	PHASE	Line 2
TESTED BY	Jamison Chan		

No	Freq. [MHz]	Corr. Factor (dB)	Reading Value		Emission Level		Limit		Margin	
			[dB (uV)]		[dB (uV)]		[dB (uV)]		(dB)	
			Q.P.	AV.	Q.P.	AV.	Q.P.	AV.	Q.P.	AV.
1	0.244	0.20	42.42	-	42.62	-	61.97	51.97	-19.35	-
2	0.365	0.20	37.77	-	37.97	-	58.62	48.62	-20.65	-
3	0.494	0.18	41.70	-	41.88	-	56.10	46.10	-14.22	-
4	1.266	0.10	35.71	-	35.81	-	56.00	46.00	-20.19	-
5	2.176	0.11	34.11	-	34.22	-	56.00	46.00	-21.78	-
6	9.211	0.46	28.27	-	28.73	-	60.00	50.00	-31.27	-

- REMARKS:**
1. Q.P. and AV. are abbreviations of quasi-peak and average individually.
 2. "-": The Quasi-peak reading value also meets average limit and measurement with the average detector is unnecessary.
 3. The emission levels of other frequencies were very low against the limit.
 4. Margin value = Emission level - Limit value
 5. Correction factor = Insertion loss + Cable loss
 6. Emission Level = Correction Factor + Reading Value.

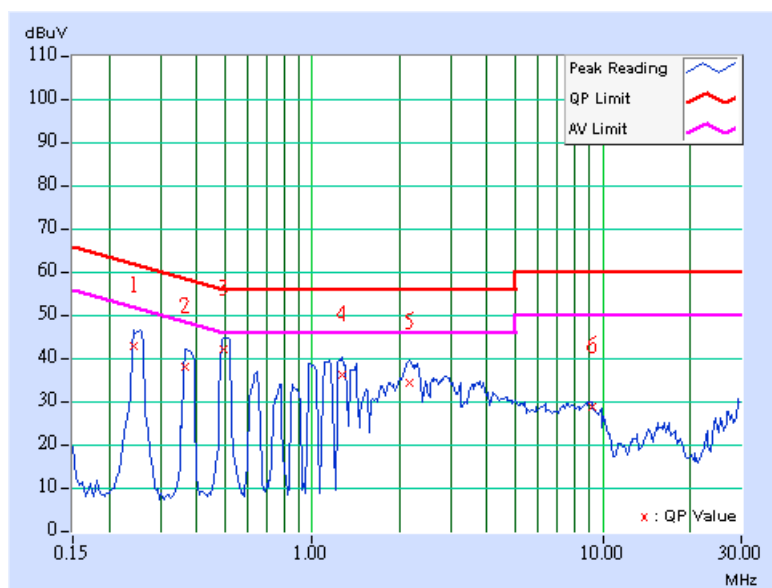

TEST MODE	A		
MODULATION TYPE	GFSK	CHANNEL	39
INPUT POWER	120Vac, 60 Hz	6dB BANDWIDTH	9 kHz
ENVIRONMENTAL CONDITIONS	27deg. C, 77%RH, 996hPa	PHASE	Line 1
TESTED BY	Jamison Chan		

No	Freq. [MHz]	Corr. Factor (dB)	Reading Value		Emission Level		Limit		Margin	
			[dB (uV)]		[dB (uV)]		[dB (uV)]		(dB)	
			Q.P.	AV.	Q.P.	AV.	Q.P.	AV.	Q.P.	AV.
1	0.244	0.20	40.37	-	40.57	-	61.97	51.97	-21.40	-
2	0.373	0.20	36.69	-	36.89	-	58.44	48.44	-21.55	-
3	0.494	0.20	44.74	-	44.94	-	56.10	46.10	-11.16	-
4	0.978	0.20	37.06	-	37.26	-	56.00	46.00	-18.74	-
5	2.156	0.31	38.63	-	38.94	-	56.00	46.00	-17.06	-
6	28.746	1.37	20.64	-	22.01	-	60.00	50.00	-37.99	-

- REMARKS:**
1. Q.P. and AV. are abbreviations of quasi-peak and average individually.
 2. "-": The Quasi-peak reading value also meets average limit and measurement with the average detector is unnecessary.
 3. The emission levels of other frequencies were very low against the limit.
 4. Margin value = Emission level - Limit value
 5. Correction factor = Insertion loss + Cable loss
 6. Emission Level = Correction Factor + Reading Value.

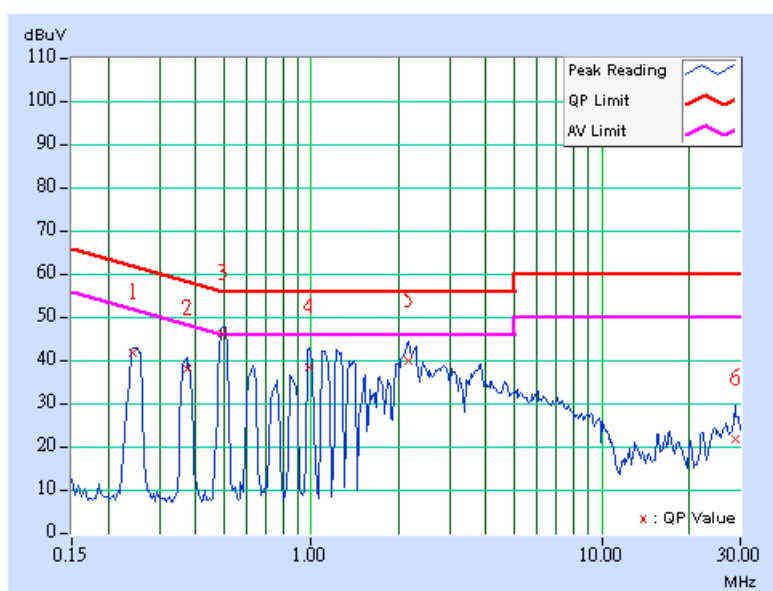

TEST MODE	A		
MODULATION TYPE	GFSK	CHANNEL	39
INPUT POWER	120Vac, 60 Hz	6dB BANDWIDTH	9 kHz
ENVIRONMENTAL CONDITIONS	27deg. C, 77%RH, 996hPa	PHASE	Line 2
TESTED BY	Jamison Chan		

No	Freq. [MHz]	Corr. Factor (dB)	Reading Value [dB (uV)]		Emission Level [dB (uV)]		Limit [dB (uV)]		Margin (dB)	
			Q.P.	AV.	Q.P.	AV.	Q.P.	AV.	Q.P.	AV.
			1	0.255	0.20	39.35	-	39.55	-	61.58
2	0.365	0.20	36.95	-	37.15	-	58.62	48.62	-21.47	-
3	0.498	0.18	41.72	-	41.90	-	56.04	46.04	-14.14	-
4	1.277	0.10	35.42	-	35.52	-	56.00	46.00	-20.48	-
5	2.145	0.11	35.08	-	35.19	-	56.00	46.00	-20.81	-
6	28.590	1.10	19.11	-	20.21	-	60.00	50.00	-39.79	-

- REMARKS:**
1. Q.P. and AV. are abbreviations of quasi-peak and average individually.
 2. "-": The Quasi-peak reading value also meets average limit and measurement with the average detector is unnecessary.
 3. The emission levels of other frequencies were very low against the limit.
 4. Margin value = Emission level - Limit value
 5. Correction factor = Insertion loss + Cable loss
 6. Emission Level = Correction Factor + Reading Value.

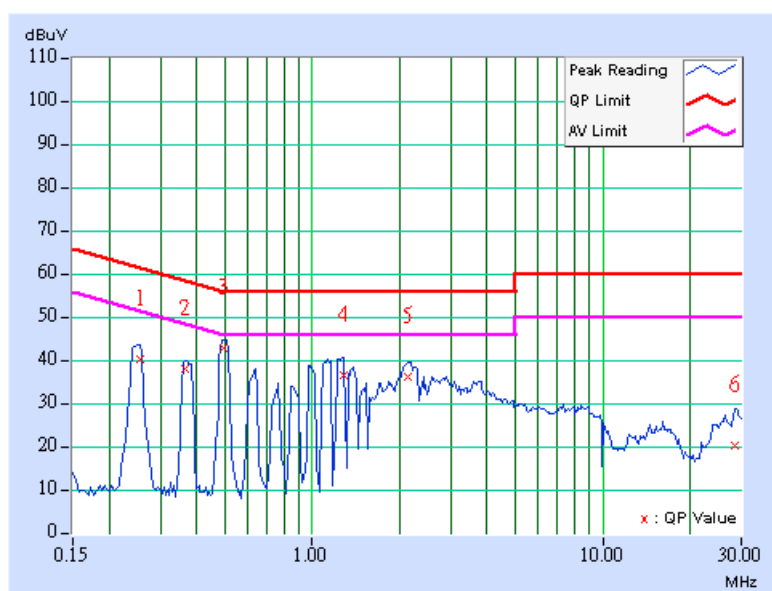

TEST MODE	A		
MODULATION TYPE	GFSK	CHANNEL	78
INPUT POWER	120Vac, 60 Hz	6dB BANDWIDTH	9 kHz
ENVIRONMENTAL CONDITIONS	27deg. C, 77%RH, 996hPa	PHASE	Line 1
TESTED BY	Jamison Chan		

No	Freq. [MHz]	Corr. Factor (dB)	Reading Value [dB (uV)]		Emission Level [dB (uV)]		Limit [dB (uV)]		Margin (dB)	
			Q.P.	AV.	Q.P.	AV.	Q.P.	AV.	Q.P.	AV.
	1	0.252	0.20	39.78	-	39.98	-	61.71	51.71	-21.73
2	0.365	0.20	38.48	-	38.68	-	58.62	48.62	-19.94	-
3	0.490	0.20	44.36	-	44.56	-	56.17	46.17	-11.61	-
4	1.250	0.23	37.96	-	38.19	-	56.00	46.00	-17.81	-
5	2.156	0.31	37.60	-	37.91	-	56.00	46.00	-18.09	-
6	28.078	1.36	17.58	-	18.94	-	60.00	50.00	-41.06	-

- REMARKS:**
1. Q.P. and AV. are abbreviations of quasi-peak and average individually.
 2. "-": The Quasi-peak reading value also meets average limit and measurement with the average detector is unnecessary.
 3. The emission levels of other frequencies were very low against the limit.
 4. Margin value = Emission level - Limit value
 5. Correction factor = Insertion loss + Cable loss
 6. Emission Level = Correction Factor + Reading Value.

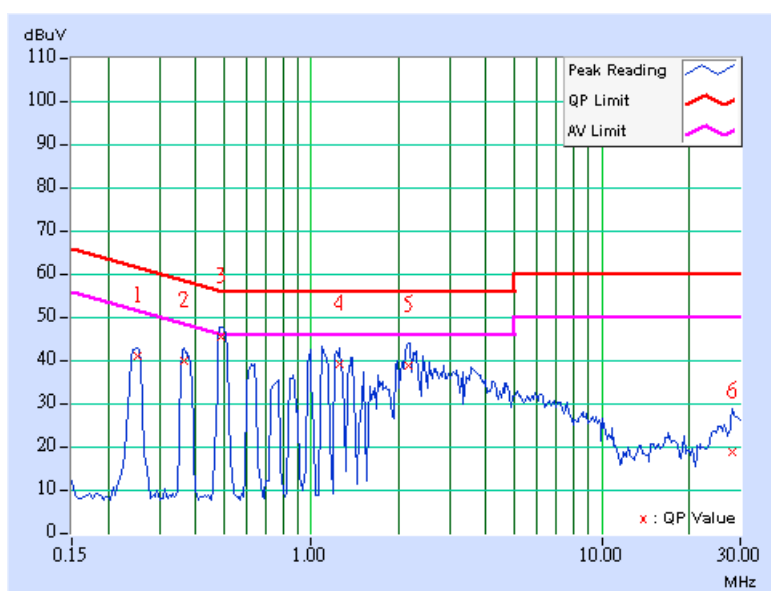

TEST MODE	A		
MODULATION TYPE	GFSK	CHANNEL	78
INPUT POWER	120Vac, 60 Hz	6dB BANDWIDTH	9 kHz
ENVIRONMENTAL CONDITIONS	27deg. C, 77%RH, 996hPa	PHASE	Line 2
TESTED BY	Jamison Chan		

No	Freq. [MHz]	Corr. Factor (dB)	Reading Value [dB (uV)]		Emission Level [dB (uV)]		Limit [dB (uV)]		Margin (dB)	
			Q.P.	AV.	Q.P.	AV.	Q.P.	AV.	Q.P.	AV.
			1	0.252	0.20	39.69	-	39.89	-	61.71
2	0.373	0.20	36.50	-	36.70	-	58.44	48.44	-21.74	-
3	0.500	0.18	41.69	-	41.87	-	56.00	46.00	-14.13	-
4	1.262	0.10	35.35	-	35.45	-	56.00	46.00	-20.55	-
5	2.176	0.11	35.56	-	35.67	-	56.00	46.00	-20.33	-
6	28.340	1.10	19.17	-	20.27	-	60.00	50.00	-39.73	-

- REMARKS:**
1. Q.P. and AV. are abbreviations of quasi-peak and average individually.
 2. "-": The Quasi-peak reading value also meets average limit and measurement with the average detector is unnecessary.
 3. The emission levels of other frequencies were very low against the limit.
 4. Margin value = Emission level - Limit value
 5. Correction factor = Insertion loss + Cable loss
 6. Emission Level = Correction Factor + Reading Value.

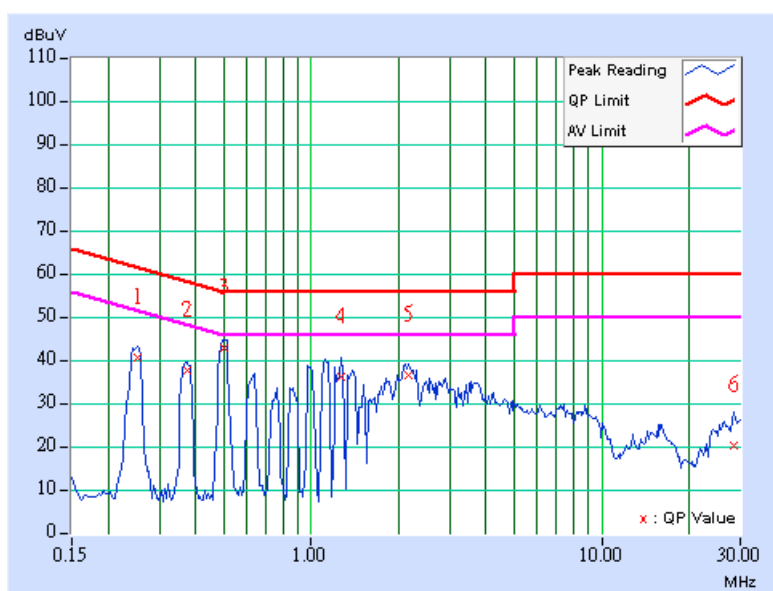

CONDUCTED WORST CASE DATA: MODE A FOR 8DPSK

TEST MODE	A		
MODULATION TYPE	8DPSK	CHANNEL	0
INPUT POWER	120Vac, 60 Hz	6dB BANDWIDTH	9 kHz
ENVIRONMENTAL CONDITIONS	27deg. C, 77%RH, 996hPa	PHASE	Line 1
TESTED BY	Jamison Chan		

No	Freq. [MHz]	Corr. Factor (dB)	Reading Value [dB (uV)]		Emission Level [dB (uV)]		Limit [dB (uV)]		Margin (dB)	
			Q.P.	AV.	Q.P.	AV.	Q.P.	AV.	Q.P.	AV.
			1	0.244	0.20	39.64	-	39.84	-	61.97
2	0.373	0.20	37.92	-	38.12	-	58.44	48.44	-20.32	-
3	0.513	0.20	42.92	-	43.12	-	56.00	46.00	-12.88	-
4	1.234	0.22	36.97	-	37.19	-	56.00	46.00	-18.81	-
5	2.168	0.31	39.34	-	39.65	-	56.00	46.00	-16.35	-
6	28.383	1.37	18.87	-	20.24	-	60.00	50.00	-39.76	-

- REMARKS:**
1. Q.P. and AV. are abbreviations of quasi-peak and average individually.
 2. "-": The Quasi-peak reading value also meets average limit and measurement with the average detector is unnecessary.
 3. The emission levels of other frequencies were very low against the limit.
 4. Margin value = Emission level - Limit value
 5. Correction factor = Insertion loss + Cable loss
 6. Emission Level = Correction Factor + Reading Value.

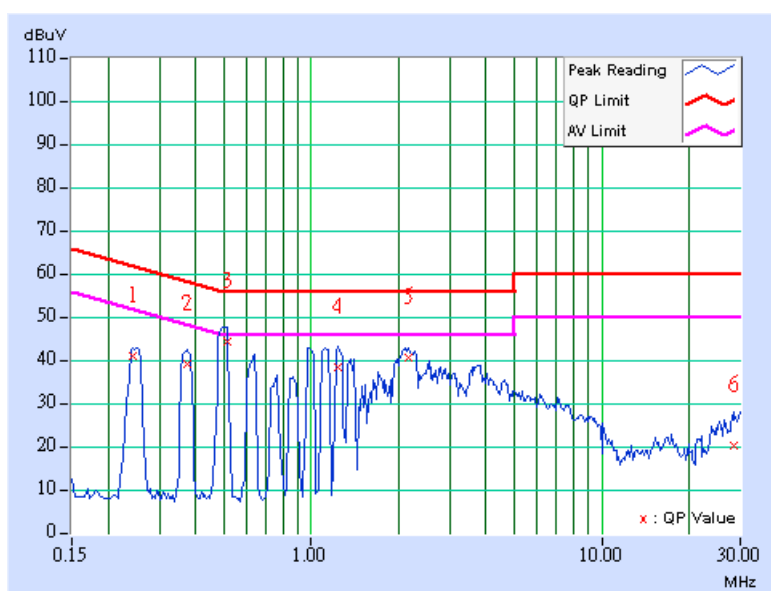

TEST MODE	A		
MODULATION TYPE	8DPSK	CHANNEL	0
INPUT POWER	120Vac, 60 Hz	6dB BANDWIDTH	9 kHz
ENVIRONMENTAL CONDITIONS	27deg. C, 77%RH, 996hPa	PHASE	Line 2
TESTED BY	Jamison Chan		

No	Freq. [MHz]	Corr. Factor (dB)	Reading Value		Emission Level		Limit		Margin	
			[dB (uV)]		[dB (uV)]		[dB (uV)]		(dB)	
			Q.P.	AV.	Q.P.	AV.	Q.P.	AV.	Q.P.	AV.
1	0.248	0.20	39.55	-	39.75	-	61.84	51.84	-22.09	-
2	0.369	0.20	36.79	-	36.99	-	58.53	48.53	-21.54	-
3	0.505	0.18	41.56	-	41.74	-	56.00	46.00	-14.26	-
4	1.211	0.10	34.67	-	34.77	-	56.00	46.00	-21.23	-
5	2.117	0.11	34.68	-	34.79	-	56.00	46.00	-21.21	-
6	28.180	1.10	17.85	-	18.95	-	60.00	50.00	-41.05	-

- REMARKS:**
1. Q.P. and AV. are abbreviations of quasi-peak and average individually.
 2. "-": The Quasi-peak reading value also meets average limit and measurement with the average detector is unnecessary.
 3. The emission levels of other frequencies were very low against the limit.
 4. Margin value = Emission level - Limit value
 5. Correction factor = Insertion loss + Cable loss
 6. Emission Level = Correction Factor + Reading Value.

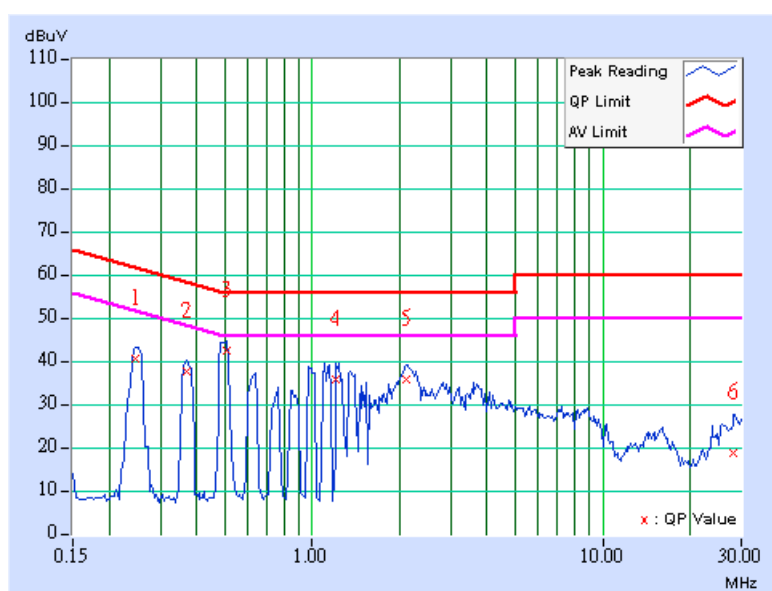

TEST MODE	A		
MODULATION TYPE	8DPSK	CHANNEL	39
INPUT POWER	120Vac, 60 Hz	6dB BANDWIDTH	9 kHz
ENVIRONMENTAL CONDITIONS	27deg. C, 77%RH, 996hPa	PHASE	Line 1
TESTED BY	Jamison Chan		

No	Freq. [MHz]	Corr. Factor (dB)	Reading Value [dB (uV)]		Emission Level [dB (uV)]		Limit [dB (uV)]		Margin (dB)	
			Q.P.	AV.	Q.P.	AV.	Q.P.	AV.	Q.P.	AV.
	1	0.248	0.20	39.87	-	40.07	-	61.84	51.84	-21.77
2	0.369	0.20	38.54	-	38.74	-	58.53	48.53	-19.79	-
3	0.494	0.20	46.13	29.50	46.33	29.70	56.10	46.10	-9.77	-16.40
4	1.258	0.23	37.48	-	37.71	-	56.00	46.00	-18.29	-
5	2.172	0.31	38.83	-	39.14	-	56.00	46.00	-16.86	-
6	28.383	1.37	17.91	-	19.28	-	60.00	50.00	-40.72	-

- REMARKS:**
1. Q.P. and AV. are abbreviations of quasi-peak and average individually.
 2. "-": The Quasi-peak reading value also meets average limit and measurement with the average detector is unnecessary.
 3. The emission levels of other frequencies were very low against the limit.
 4. Margin value = Emission level - Limit value
 5. Correction factor = Insertion loss + Cable loss
 6. Emission Level = Correction Factor + Reading Value.

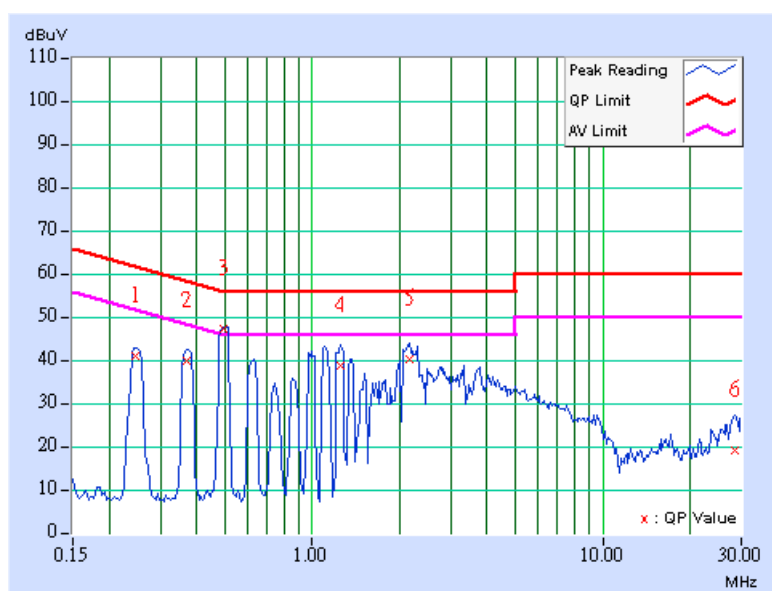

TEST MODE	A		
MODULATION TYPE	8DPSK	CHANNEL	39
INPUT POWER	120Vac, 60 Hz	6dB BANDWIDTH	9 kHz
ENVIRONMENTAL CONDITIONS	27deg. C, 77%RH, 996hPa	PHASE	Line 2
TESTED BY	Jamison Chan		

No	Freq. [MHz]	Corr. Factor (dB)	Reading Value		Emission Level		Limit		Margin	
			[dB (uV)]		[dB (uV)]		[dB (uV)]		(dB)	
			Q.P.	AV.	Q.P.	AV.	Q.P.	AV.	Q.P.	AV.
1	0.252	0.20	39.71	-	39.91	-	61.71	51.71	-21.80	-
2	0.369	0.20	36.27	-	36.47	-	58.53	48.53	-22.06	-
3	0.502	0.18	42.84	-	43.02	-	56.00	46.00	-12.98	-
4	1.211	0.10	33.92	-	34.02	-	56.00	46.00	-21.98	-
5	2.160	0.11	35.12	-	35.23	-	56.00	46.00	-20.77	-
6	27.949	1.10	18.32	-	19.42	-	60.00	50.00	-40.58	-

- REMARKS:**
1. Q.P. and AV. are abbreviations of quasi-peak and average individually.
 2. "-": The Quasi-peak reading value also meets average limit and measurement with the average detector is unnecessary.
 3. The emission levels of other frequencies were very low against the limit.
 4. Margin value = Emission level - Limit value
 5. Correction factor = Insertion loss + Cable loss
 6. Emission Level = Correction Factor + Reading Value.

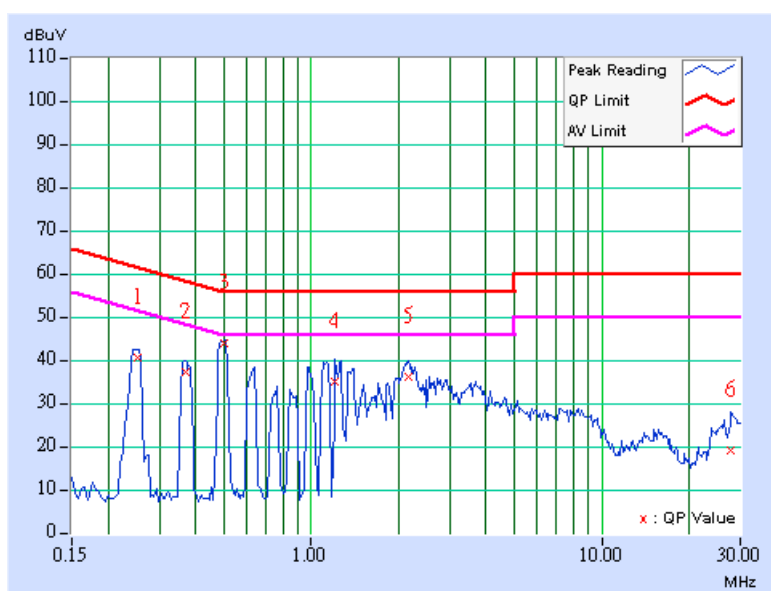

TEST MODE	A		
MODULATION TYPE	8DPSK	CHANNEL	78
INPUT POWER	120Vac, 60 Hz	6dB BANDWIDTH	9 kHz
ENVIRONMENTAL CONDITIONS	27deg. C, 77%RH, 996hPa	PHASE	Line 1
TESTED BY	Jamison Chan		

No	Freq. [MHz]	Corr. Factor (dB)	Reading Value [dB (uV)]		Emission Level [dB (uV)]		Limit [dB (uV)]		Margin (dB)	
			Q.P.	AV.	Q.P.	AV.	Q.P.	AV.	Q.P.	AV.
			1	0.244	0.20	39.58	-	39.78	-	61.97
2	0.369	0.20	38.68	-	38.88	-	58.53	48.53	-19.65	-
3	0.498	0.20	44.80	-	45.00	-	56.04	46.04	-11.04	-
4	1.129	0.21	38.32	-	38.53	-	56.00	46.00	-17.47	-
5	2.168	0.31	39.83	-	40.14	-	56.00	46.00	-15.86	-
6	28.605	1.37	17.95	-	19.32	-	60.00	50.00	-40.68	-

- REMARKS:**
1. Q.P. and AV. are abbreviations of quasi-peak and average individually.
 2. "-": The Quasi-peak reading value also meets average limit and measurement with the average detector is unnecessary.
 3. The emission levels of other frequencies were very low against the limit.
 4. Margin value = Emission level - Limit value
 5. Correction factor = Insertion loss + Cable loss
 6. Emission Level = Correction Factor + Reading Value.

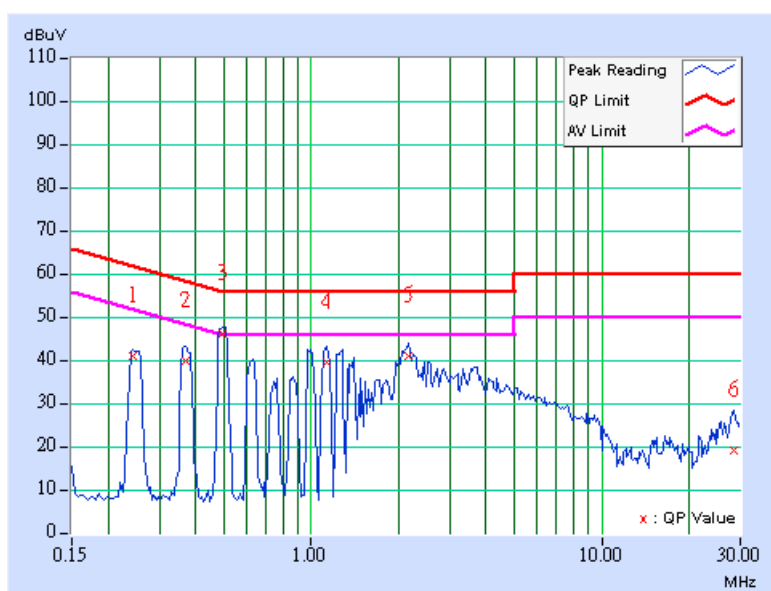

TEST MODE	A		
MODULATION TYPE	8DPSK	CHANNEL	78
INPUT POWER	120Vac, 60 Hz	6dB BANDWIDTH	9 kHz
ENVIRONMENTAL CONDITIONS	27deg. C, 77%RH, 996hPa	PHASE	Line 2
TESTED BY	Jamison Chan		

No	Freq. [MHz]	Corr. Factor (dB)	Reading Value [dB (uV)]		Emission Level [dB (uV)]		Limit [dB (uV)]		Margin (dB)	
			Q.P.	AV.	Q.P.	AV.	Q.P.	AV.	Q.P.	AV.
	1	0.248	0.20	39.53	-	39.73	-	61.84	51.84	-22.11
2	0.369	0.20	36.85	-	37.05	-	58.53	48.53	-21.48	-
3	0.500	0.18	41.67	-	41.85	-	56.00	46.00	-14.15	-
4	1.281	0.10	35.20	-	35.30	-	56.00	46.00	-20.70	-
5	2.152	0.11	34.75	-	34.86	-	56.00	46.00	-21.14	-
6	28.141	1.10	17.93	-	19.03	-	60.00	50.00	-40.97	-

- REMARKS:**
1. Q.P. and AV. are abbreviations of quasi-peak and average individually.
 2. "-": The Quasi-peak reading value also meets average limit and measurement with the average detector is unnecessary.
 3. The emission levels of other frequencies were very low against the limit.
 4. Margin value = Emission level - Limit value
 5. Correction factor = Insertion loss + Cable loss
 6. Emission Level = Correction Factor + Reading Value.

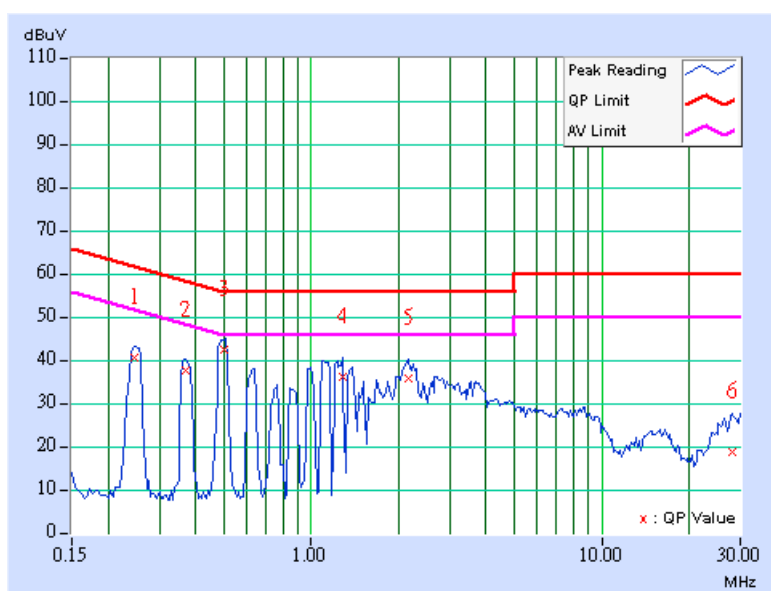

CONDUCTED WORST CASE DATA: MODE B FOR GFSK

TEST MODE	B		
MODULATION TYPE	GFSK	CHANNEL	0
INPUT POWER	120Vac, 60 Hz	6dB BANDWIDTH	9 kHz
ENVIRONMENTAL CONDITIONS	25deg. C, 60%RH, 976hPa	PHASE	Line 1
TESTED BY	Jamison Chan		

No	Freq. [MHz]	Corr. Factor (dB)	Reading Value [dB (uV)]		Emission Level [dB (uV)]		Limit [dB (uV)]		Margin (dB)	
			Q.P.	AV.	Q.P.	AV.	Q.P.	AV.	Q.P.	AV.
			1	0.348	0.20	19.84	-	20.04	-	59.01
2	0.414	0.20	28.13	-	28.33	-	57.57	47.57	-29.24	-
3	0.867	0.20	21.61	-	21.81	-	56.00	46.00	-34.19	-
4	2.113	0.21	26.86	-	27.07	-	56.00	46.00	-28.93	-
5	5.228	0.36	20.12	-	20.48	-	60.00	50.00	-39.52	-
6	6.506	0.43	17.87	-	18.30	-	60.00	50.00	-41.70	-

- REMARKS:**
1. Q.P. and AV. are abbreviations of quasi-peak and average individually.
 2. "-": The Quasi-peak reading value also meets average limit and measurement with the average detector is unnecessary.
 3. The emission levels of other frequencies were very low against the limit.
 4. Margin value = Emission level - Limit value
 5. Correction factor = Insertion loss + Cable loss
 6. Emission Level = Correction Factor + Reading Value.

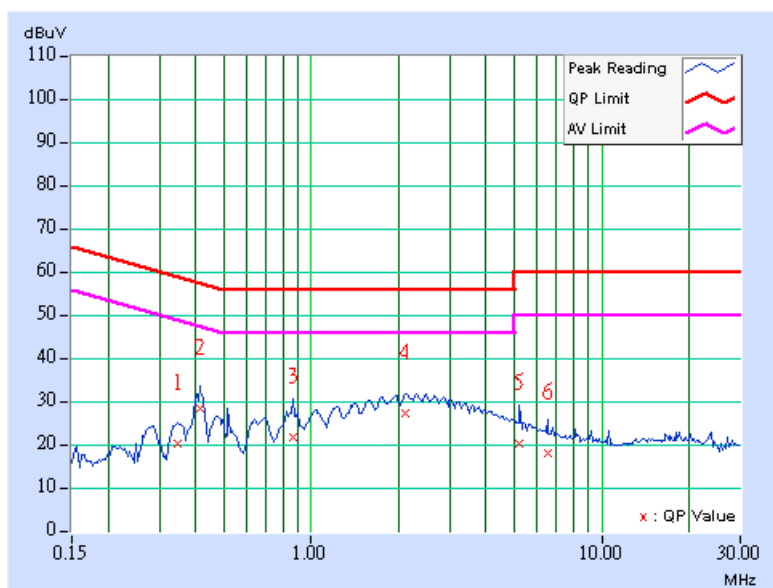

TEST MODE	B		
MODULATION TYPE	GFSK	CHANNEL	0
INPUT POWER	120Vac, 60 Hz	6dB BANDWIDTH	9 kHz
ENVIRONMENTAL CONDITIONS	25deg. C, 60%RH, 976hPa	PHASE	Line 2
TESTED BY	Jamison Chan		

No	Freq. [MHz]	Corr. Factor (dB)	Reading Value		Emission Level		Limit		Margin	
			[dB (uV)]		[dB (uV)]		[dB (uV)]		(dB)	
			Q.P.	AV.	Q.P.	AV.	Q.P.	AV.	Q.P.	AV.
1	0.342	0.20	15.66	-	15.86	-	59.15	49.15	-43.29	-
2	0.414	0.20	22.09	-	22.29	-	57.57	47.57	-35.28	-
3	2.017	0.20	20.17	-	20.37	-	56.00	46.00	-35.63	-
4	2.914	0.25	20.45	-	20.70	-	56.00	46.00	-35.30	-
5	5.192	0.36	14.02	-	14.38	-	60.00	50.00	-45.62	-
6	5.558	0.38	12.16	-	12.54	-	60.00	50.00	-47.46	-

- REMARKS:**
1. Q.P. and AV. are abbreviations of quasi-peak and average individually.
 2. "-": The Quasi-peak reading value also meets average limit and measurement with the average detector is unnecessary.
 3. The emission levels of other frequencies were very low against the limit.
 4. Margin value = Emission level - Limit value
 5. Correction factor = Insertion loss + Cable loss
 6. Emission Level = Correction Factor + Reading Value.

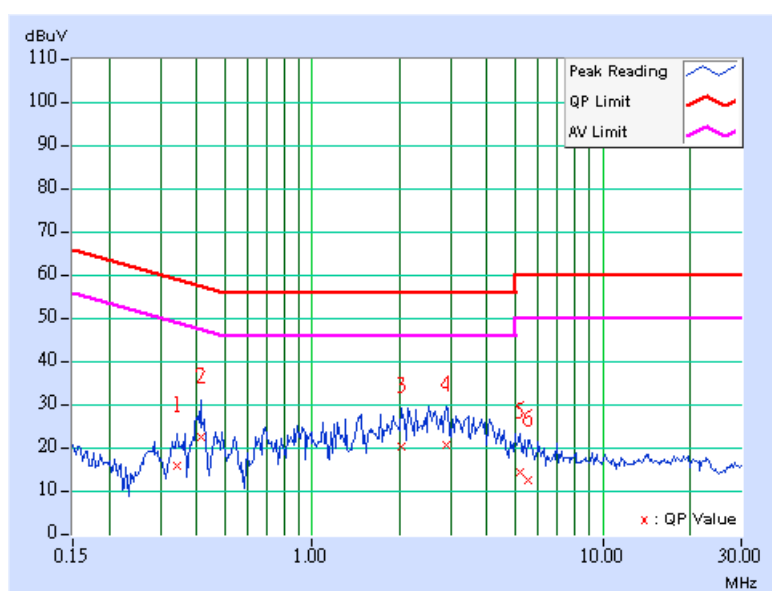

TEST MODE	B		
MODULATION TYPE	GFSK	CHANNEL	39
INPUT POWER	120Vac, 60 Hz	6dB BANDWIDTH	9 kHz
ENVIRONMENTAL CONDITIONS	25deg. C, 60%RH, 976hPa	PHASE	Line 1
TESTED BY	Jamison Chan		

No	Freq. [MHz]	Corr. Factor (dB)	Reading Value [dB (uV)]		Emission Level [dB (uV)]		Limit [dB (uV)]		Margin (dB)	
			Q.P.	AV.	Q.P.	AV.	Q.P.	AV.	Q.P.	AV.
			1	0.348	0.20	19.92	-	20.12	-	59.01
2	0.411	0.20	28.13	-	28.33	-	57.63	47.63	-29.30	-
3	1.582	0.20	25.50	-	25.70	-	56.00	46.00	-30.30	-
4	2.269	0.21	26.35	-	26.56	-	56.00	46.00	-29.44	-
5	5.198	0.36	19.20	-	19.56	-	60.00	50.00	-40.44	-
6	6.320	0.42	18.00	-	18.42	-	60.00	50.00	-41.58	-

- REMARKS:**
1. Q.P. and AV. are abbreviations of quasi-peak and average individually.
 2. "-": The Quasi-peak reading value also meets average limit and measurement with the average detector is unnecessary.
 3. The emission levels of other frequencies were very low against the limit.
 4. Margin value = Emission level - Limit value
 5. Correction factor = Insertion loss + Cable loss
 6. Emission Level = Correction Factor + Reading Value.

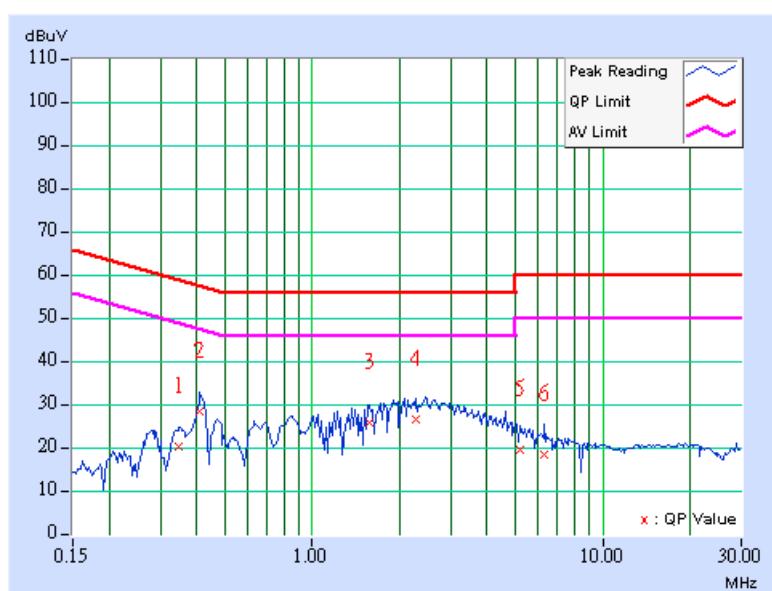

TEST MODE	B		
MODULATION TYPE	GFSK	CHANNEL	39
INPUT POWER	120Vac, 60 Hz	6dB BANDWIDTH	9 kHz
ENVIRONMENTAL CONDITIONS	25deg. C, 60%RH, 976hPa	PHASE	Line 2
TESTED BY	Jamison Chan		

No	Freq. [MHz]	Corr. Factor (dB)	Reading Value [dB (uV)]		Emission Level [dB (uV)]		Limit [dB (uV)]		Margin (dB)	
			Q.P.	AV.	Q.P.	AV.	Q.P.	AV.	Q.P.	AV.
			1	0.411	0.20	22.51	-	22.71	-	57.63
2	0.462	0.20	15.72	-	15.92	-	56.66	46.66	-40.74	-
3	1.444	0.20	18.54	-	18.74	-	56.00	46.00	-37.26	-
4	2.698	0.23	21.33	-	21.56	-	56.00	46.00	-34.44	-
5	5.600	0.38	14.53	-	14.91	-	60.00	50.00	-45.09	-
6	6.140	0.41	11.06	-	11.47	-	60.00	50.00	-48.53	-

- REMARKS:**
1. Q.P. and AV. are abbreviations of quasi-peak and average individually.
 2. "-": The Quasi-peak reading value also meets average limit and measurement with the average detector is unnecessary.
 3. The emission levels of other frequencies were very low against the limit.
 4. Margin value = Emission level - Limit value
 5. Correction factor = Insertion loss + Cable loss
 6. Emission Level = Correction Factor + Reading Value.

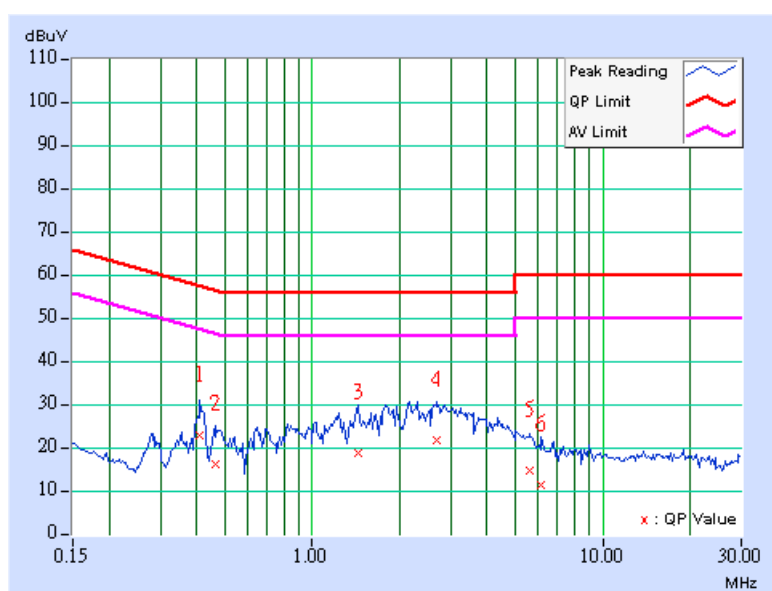

TEST MODE	B		
MODULATION TYPE	GFSK	CHANNEL	78
INPUT POWER	120Vac, 60 Hz	6dB BANDWIDTH	9 kHz
ENVIRONMENTAL CONDITIONS	25deg. C, 60%RH, 976hPa	PHASE	Line 1
TESTED BY	Jamison Chan		

No	Freq. [MHz]	Corr. Factor (dB)	Reading Value [dB (uV)]		Emission Level [dB (uV)]		Limit [dB (uV)]		Margin (dB)	
			Q.P.	AV.	Q.P.	AV.	Q.P.	AV.	Q.P.	AV.
			1	0.417	0.20	27.83	-	28.03	-	57.51
2	0.465	0.20	21.47	-	21.67	-	56.60	46.60	-34.93	-
3	1.285	0.20	21.34	-	21.54	-	56.00	46.00	-34.46	-
4	2.110	0.21	26.72	-	26.93	-	56.00	46.00	-29.07	-
5	5.351	0.37	17.60	-	17.97	-	60.00	50.00	-42.03	-
6	5.867	0.39	14.14	-	14.53	-	60.00	50.00	-45.47	-

- REMARKS:**
1. Q.P. and AV. are abbreviations of quasi-peak and average individually.
 2. "-": The Quasi-peak reading value also meets average limit and measurement with the average detector is unnecessary.
 3. The emission levels of other frequencies were very low against the limit.
 4. Margin value = Emission level - Limit value
 5. Correction factor = Insertion loss + Cable loss
 6. Emission Level = Correction Factor + Reading Value.

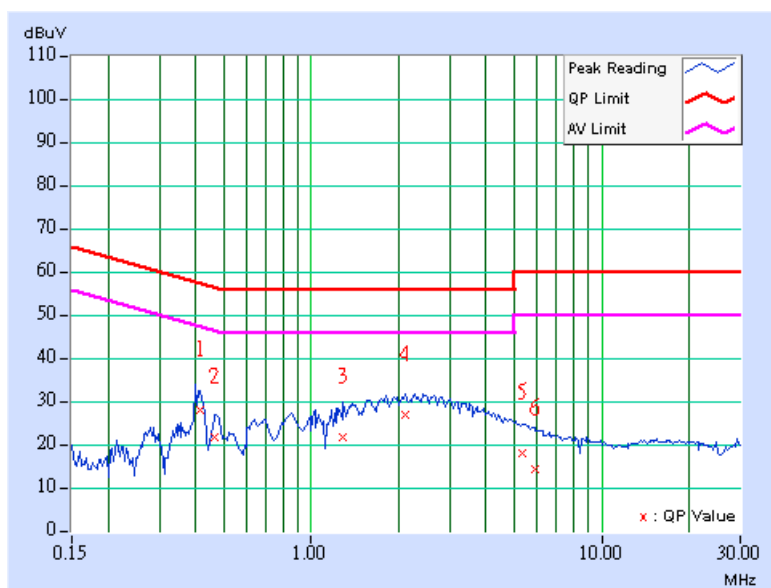

TEST MODE	B		
MODULATION TYPE	GFSK	CHANNEL	78
INPUT POWER	120Vac, 60 Hz	6dB BANDWIDTH	9 kHz
ENVIRONMENTAL CONDITIONS	25deg. C, 60%RH, 976hPa	PHASE	Line 2
TESTED BY	Jamison Chan		

No	Freq. [MHz]	Corr. Factor (dB)	Reading Value [dB (uV)]		Emission Level [dB (uV)]		Limit [dB (uV)]		Margin (dB)	
			Q.P.	AV.	Q.P.	AV.	Q.P.	AV.	Q.P.	AV.
			1	0.408	0.20	22.21	-	22.41	-	57.69
2	0.492	0.20	13.76	-	13.96	-	56.13	46.13	-42.17	-
3	1.819	0.20	18.86	-	19.06	-	56.00	46.00	-36.94	-
4	2.359	0.22	20.10	-	20.32	-	56.00	46.00	-35.68	-
5	5.921	0.40	12.30	-	12.70	-	60.00	50.00	-47.30	-
6	16.568	0.83	10.32	-	11.15	-	60.00	50.00	-48.85	-

- REMARKS:**
1. Q.P. and AV. are abbreviations of quasi-peak and average individually.
 2. "-": The Quasi-peak reading value also meets average limit and measurement with the average detector is unnecessary.
 3. The emission levels of other frequencies were very low against the limit.
 4. Margin value = Emission level - Limit value
 5. Correction factor = Insertion loss + Cable loss
 6. Emission Level = Correction Factor + Reading Value.

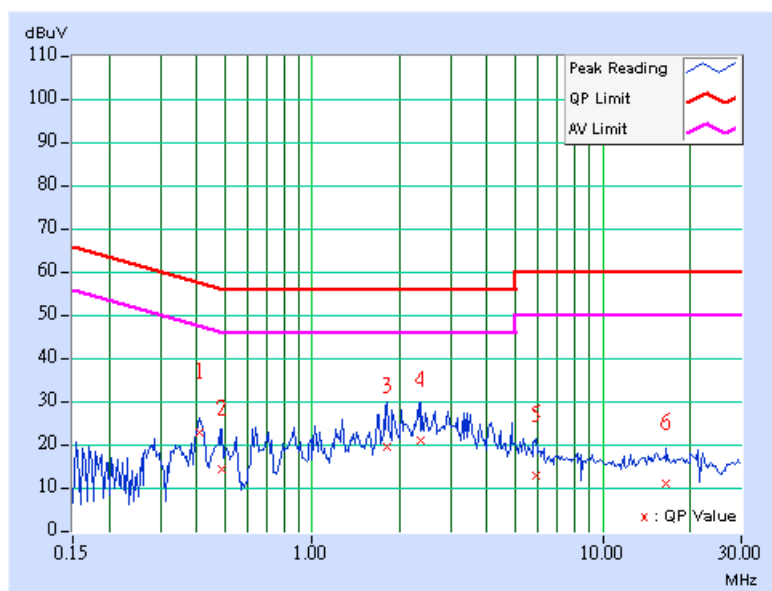

CONDUCTED WORST CASE DATA: MODE B FOR 8DPSK

TEST MODE	B		
MODULATION TYPE	8DPSK	CHANNEL	0
INPUT POWER	120Vac, 60 Hz	6dB BANDWIDTH	9 kHz
ENVIRONMENTAL CONDITIONS	25deg. C, 60%RH, 976hPa	PHASE	Line 1
TESTED BY	Jamison Chan		

No	Freq. [MHz]	Corr. Factor (dB)	Reading Value [dB (uV)]		Emission Level [dB (uV)]		Limit [dB (uV)]		Margin (dB)	
			Q.P.	AV.	Q.P.	AV.	Q.P.	AV.	Q.P.	AV.
			1	0.411	0.20	28.17	-	28.37	-	57.63
2	0.477	0.20	21.59	-	21.79	-	56.39	46.39	-34.60	-
3	1.942	0.20	26.47	-	26.67	-	56.00	46.00	-29.33	-
4	2.296	0.21	26.95	-	27.16	-	56.00	46.00	-28.84	-
5	5.513	0.38	15.02	-	15.40	-	60.00	50.00	-44.60	-
6	7.157	0.46	15.09	-	15.55	-	60.00	50.00	-44.45	-

- REMARKS:**
1. Q.P. and AV. are abbreviations of quasi-peak and average individually.
 2. "-": The Quasi-peak reading value also meets average limit and measurement with the average detector is unnecessary.
 3. The emission levels of other frequencies were very low against the limit.
 4. Margin value = Emission level - Limit value
 5. Correction factor = Insertion loss + Cable loss
 6. Emission Level = Correction Factor + Reading Value.

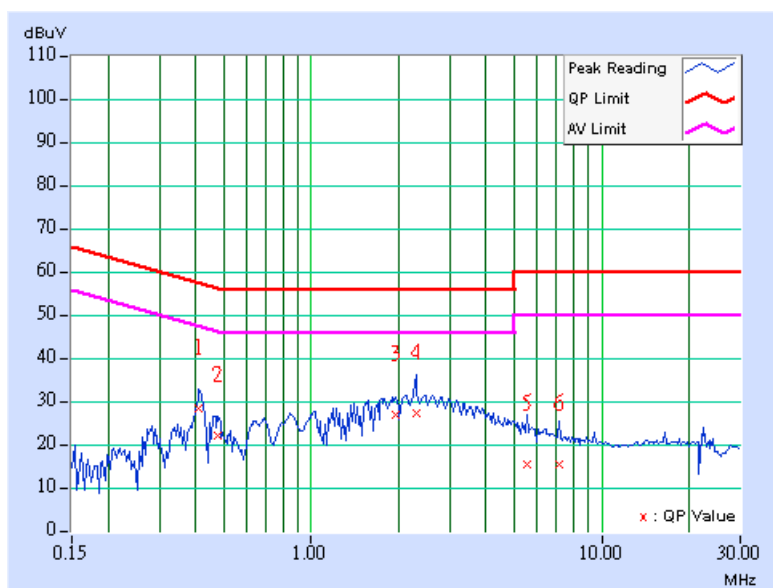

TEST MODE	B		
MODULATION TYPE	8DPSK	CHANNEL	0
INPUT POWER	120Vac, 60 Hz	6dB BANDWIDTH	9 kHz
ENVIRONMENTAL CONDITIONS	25deg. C, 60%RH, 976hPa	PHASE	Line 2
TESTED BY	Jamison Chan		

No	Freq. [MHz]	Corr. Factor (dB)	Reading Value		Emission Level		Limit		Margin	
			[dB (uV)]		[dB (uV)]		[dB (uV)]		(dB)	
			Q.P.	AV.	Q.P.	AV.	Q.P.	AV.	Q.P.	AV.
1	0.399	0.20	18.55	-	18.75	-	57.87	47.87	-39.12	-
2	0.453	0.20	13.72	-	13.92	-	56.82	46.82	-42.90	-
3	1.906	0.20	20.54	-	20.74	-	56.00	46.00	-35.26	-
4	2.122	0.21	21.42	-	21.63	-	56.00	46.00	-34.37	-
5	5.348	0.37	15.23	-	15.60	-	60.00	50.00	-44.40	-
6	5.870	0.39	11.92	-	12.31	-	60.00	50.00	-47.69	-

- REMARKS:**
1. Q.P. and AV. are abbreviations of quasi-peak and average individually.
 2. "-": The Quasi-peak reading value also meets average limit and measurement with the average detector is unnecessary.
 3. The emission levels of other frequencies were very low against the limit.
 4. Margin value = Emission level - Limit value
 5. Correction factor = Insertion loss + Cable loss
 6. Emission Level = Correction Factor + Reading Value.

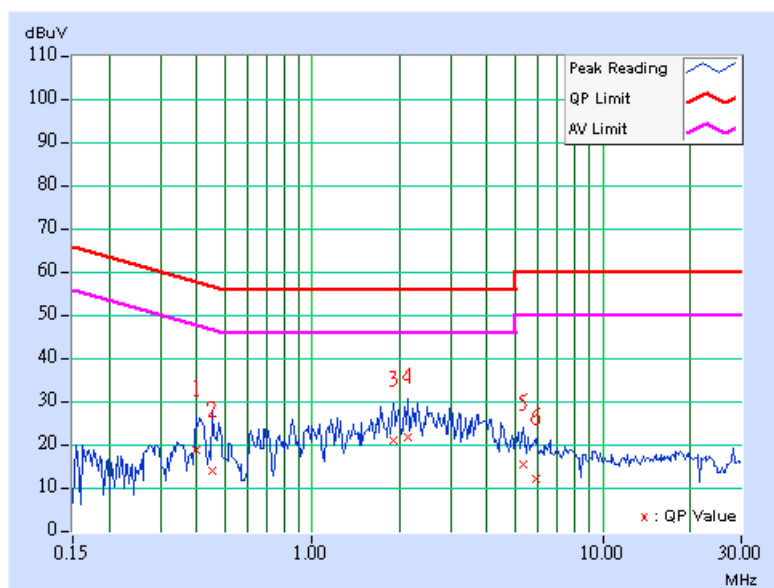

TEST MODE	B		
MODULATION TYPE	8DPSK	CHANNEL	39
INPUT POWER	120Vac, 60 Hz	6dB BANDWIDTH	9 kHz
ENVIRONMENTAL CONDITIONS	25deg. C, 60%RH, 976hPa	PHASE	Line 1
TESTED BY	Jamison Chan		

No	Freq. [MHz]	Corr. Factor (dB)	Reading Value [dB (uV)]		Emission Level [dB (uV)]		Limit [dB (uV)]		Margin (dB)	
			Q.P.	AV.	Q.P.	AV.	Q.P.	AV.	Q.P.	AV.
			1	0.411	0.20	28.09	-	28.29	-	57.63
2	0.513	0.20	16.32	-	16.52	-	56.00	46.00	-39.48	-
3	1.981	0.20	25.64	-	25.84	-	56.00	46.00	-30.16	-
4	3.478	0.27	22.10	-	22.37	-	56.00	46.00	-33.63	-
5	5.600	0.38	19.25	-	19.63	-	60.00	50.00	-40.37	-
6	9.290	0.56	15.34	-	15.90	-	60.00	50.00	-44.10	-

- REMARKS:**
1. Q.P. and AV. are abbreviations of quasi-peak and average individually.
 2. "-": The Quasi-peak reading value also meets average limit and measurement with the average detector is unnecessary.
 3. The emission levels of other frequencies were very low against the limit.
 4. Margin value = Emission level - Limit value
 5. Correction factor = Insertion loss + Cable loss
 6. Emission Level = Correction Factor + Reading Value.

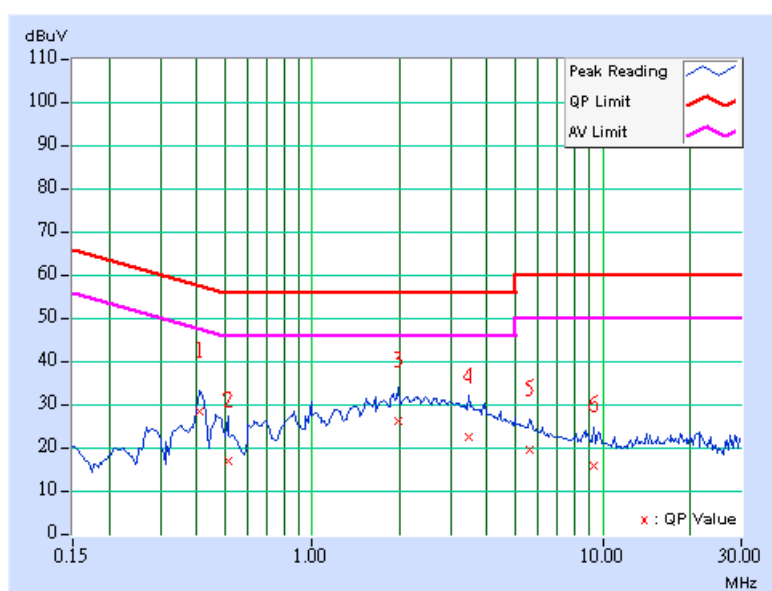

TEST MODE	B		
MODULATION TYPE	8DPSK	CHANNEL	39
INPUT POWER	120Vac, 60 Hz	6dB BANDWIDTH	9 kHz
ENVIRONMENTAL CONDITIONS	25deg. C, 60%RH, 976hPa	PHASE	Line 2
TESTED BY	Jamison Chan		

No	Freq. [MHz]	Corr. Factor (dB)	Reading Value [dB (uV)]		Emission Level [dB (uV)]		Limit [dB (uV)]		Margin (dB)	
			Q.P.	AV.	Q.P.	AV.	Q.P.	AV.	Q.P.	AV.
			1	0.414	0.20	22.39	-	22.59	-	57.57
2	0.465	0.20	16.10	-	16.30	-	56.60	46.60	-40.30	-
3	1.975	0.20	20.30	-	20.50	-	56.00	46.00	-35.50	-
4	2.305	0.22	21.53	-	21.75	-	56.00	46.00	-34.25	-
5	5.051	0.35	14.95	-	15.30	-	60.00	50.00	-44.70	-
6	20.360	0.91	12.30	-	13.21	-	60.00	50.00	-46.79	-

- REMARKS:**
1. Q.P. and AV. are abbreviations of quasi-peak and average individually.
 2. "-": The Quasi-peak reading value also meets average limit and measurement with the average detector is unnecessary.
 3. The emission levels of other frequencies were very low against the limit.
 4. Margin value = Emission level - Limit value
 5. Correction factor = Insertion loss + Cable loss
 6. Emission Level = Correction Factor + Reading Value.

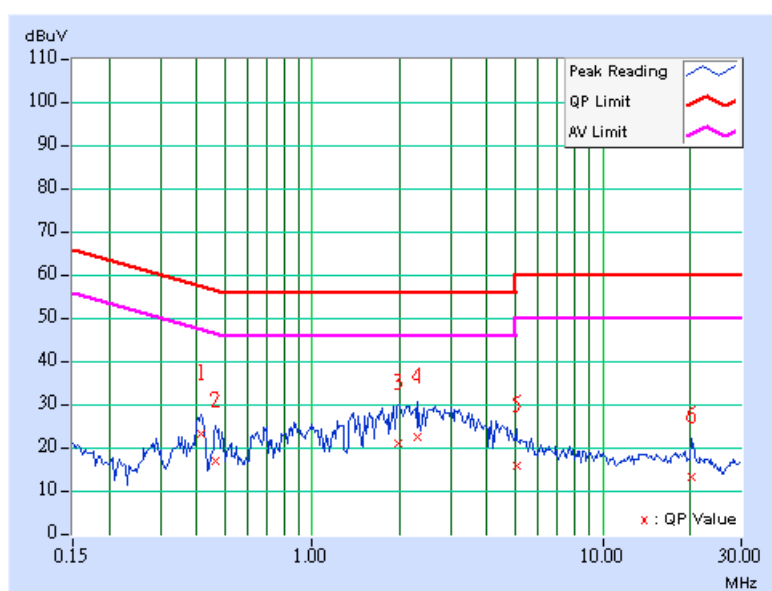

TEST MODE	B		
MODULATION TYPE	8DPSK	CHANNEL	78
INPUT POWER	120Vac, 60 Hz	6dB BANDWIDTH	9 kHz
ENVIRONMENTAL CONDITIONS	25deg. C, 60%RH, 976hPa	PHASE	Line 1
TESTED BY	Jamison Chan		

No	Freq. [MHz]	Corr. Factor (dB)	Reading Value [dB (uV)]		Emission Level [dB (uV)]		Limit [dB (uV)]		Margin (dB)	
			Q.P.	AV.	Q.P.	AV.	Q.P.	AV.	Q.P.	AV.
			1	0.414	0.20	28.37	-	28.57	-	57.57
2	0.471	0.20	21.87	-	22.07	-	56.50	46.50	-34.43	-
3	1.720	0.20	26.01	-	26.21	-	56.00	46.00	-29.79	-
4	2.278	0.21	26.77	-	26.98	-	56.00	46.00	-29.02	-
5	5.351	0.37	19.27	-	19.64	-	60.00	50.00	-40.36	-
6	5.915	0.40	17.22	-	17.62	-	60.00	50.00	-42.38	-

- REMARKS:**
1. Q.P. and AV. are abbreviations of quasi-peak and average individually.
 2. "-": The Quasi-peak reading value also meets average limit and measurement with the average detector is unnecessary.
 3. The emission levels of other frequencies were very low against the limit.
 4. Margin value = Emission level - Limit value
 5. Correction factor = Insertion loss + Cable loss
 6. Emission Level = Correction Factor + Reading Value.

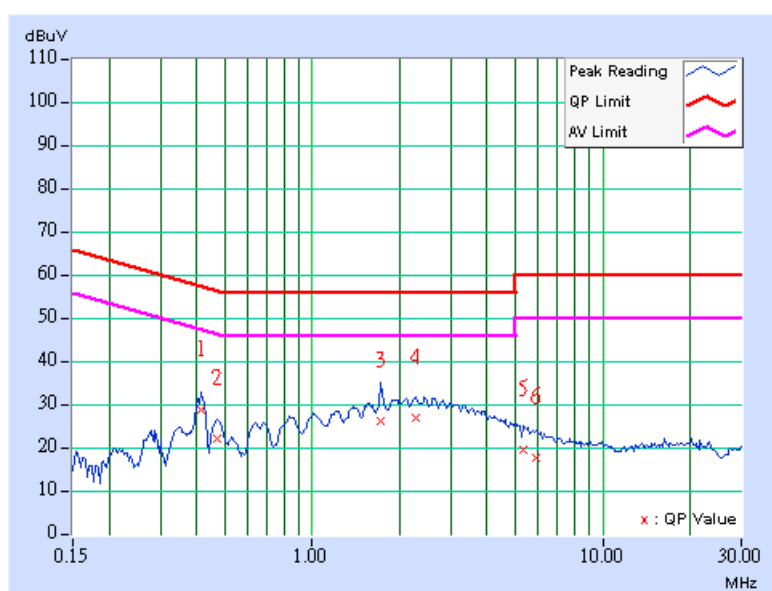

TEST MODE	B		
MODULATION TYPE	8DPSK	CHANNEL	78
INPUT POWER	120Vac, 60 Hz	6dB BANDWIDTH	9 kHz
ENVIRONMENTAL CONDITIONS	25deg. C, 60%RH, 976hPa	PHASE	Line 2
TESTED BY	Jamison Chan		

No	Freq. [MHz]	Corr. Factor (dB)	Reading Value [dB (uV)]		Emission Level [dB (uV)]		Limit [dB (uV)]		Margin (dB)	
			Q.P.	AV.	Q.P.	AV.	Q.P.	AV.	Q.P.	AV.
	1	0.408	0.20	22.07	-	22.27	-	57.69	47.69	-35.42
2	0.474	0.20	16.43	-	16.63	-	56.44	46.44	-39.81	-
3	2.263	0.21	21.16	-	21.37	-	56.00	46.00	-34.63	-
4	2.263	0.21	20.94	-	21.15	-	56.00	46.00	-34.85	-
5	5.348	0.37	13.73	-	14.10	-	60.00	50.00	-45.90	-
6	7.190	0.46	12.30	-	12.76	-	60.00	50.00	-47.24	-

- REMARKS:**
1. Q.P. and AV. are abbreviations of quasi-peak and average individually.
 2. "-": The Quasi-peak reading value also meets average limit and measurement with the average detector is unnecessary.
 3. The emission levels of other frequencies were very low against the limit.
 4. Margin value = Emission level - Limit value
 5. Correction factor = Insertion loss + Cable loss
 6. Emission Level = Correction Factor + Reading Value.

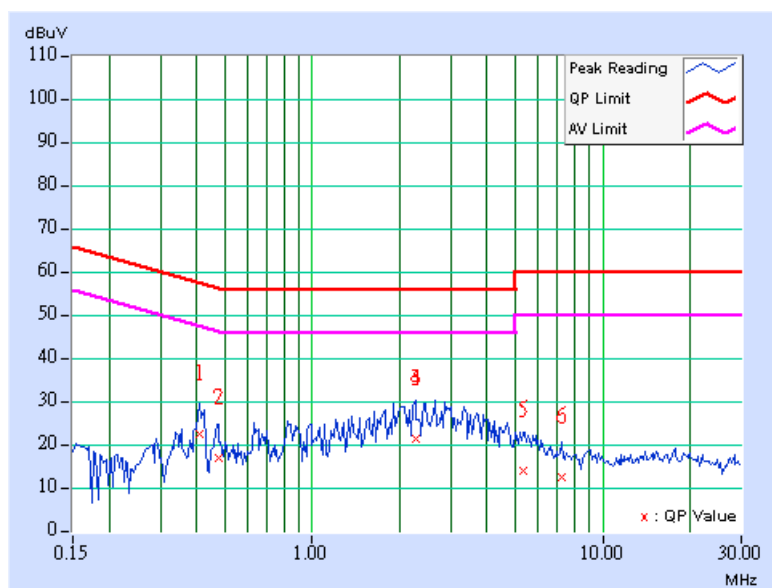

4.2 RADIATED EMISSION MEASUREMENT

4.2.1 LIMITS OF RADIATED EMISSION MEASUREMENT

Emissions radiated outside of the specified bands, shall be according to the general radiated limits in 15.209 as following:

FREQUENCIES (MHz)	FIELD STRENGTH (microvolts/meter)	MEASUREMENT DISTANCE (meters)
0.009 ~ 0.490	2400/F(kHz)	300
0.490 ~ 1.705	24000/F(kHz)	30
1.705 ~ 30.0	30	30
30 ~ 88	100	3
88 ~ 216	150	3
216 ~ 960	200	3
Above 960	500	3

NOTE:

1. The lower limit shall apply at the transition frequencies.
2. Emission level (dBuV/m) = 20 log Emission level (uV/m).
3. As shown in 15.35(b), for frequencies above 1000MHz, the field strength limits are based on average detector, however, the peak field strength of any emission shall not exceed the maximum permitted average limits, specified above by more than 20dB under any condition of modulation.

4.2.2 TEST INSTRUMENTS

DESCRIPTION & MANUFACTURER	MODEL NO.	SERIAL NO.	CALIBRATED UNTIL
HP Preamplifier	8447D	2432A03504	May 21, 2007
HP Preamplifier	8449B	3008A01924	Sep. 06, 2006
HP Preamplifier	8449B	3008A01638	Sep. 21, 2006
ROHDE & SCHWARZ TEST RECEIVER	ESI7	836697/012	Nov. 01, 2006
Schwarzbeck Antenna	VULB 9168	137	Feb. 21, 2007
Schwarzbeck Antenna	VHBA 9123	480	Mar. 30, 2007
EMCO Horn Antenna	3115	6714	Oct. 26, 2006
EMCO Horn Antenna	3115	9312-4192	Mar. 14, 2007
ADT. Turn Table	TT100	0306	NA
ADT. Tower	AT100	0306	NA
Software	ADT_Radiated_V 7.6.011	NA	NA
TIMES RF cable	LL142	CABLE-CH6-01	Dec. 19, 2006
ROHDE & SCHWARZ Spectrum Analyzer	FSP 40	100036	Mar. 16. 2007

- NOTE:**
1. The calibration interval of the above test instruments is 12 months. And the calibrations are traceable to NML/ROC and NIST/USA.
 2. The horn antenna and HP preamplifier (model: 8449B) are used only for the measurement of emission frequency above 1GHz if tested.
 3. The test was performed in ADT Chamber No. 6.
 4. The Industry Canada Reference No. IC 3789-6.

4.2.3 TEST PROCEDURES

- a. The EUT was placed on the top of a rotating table 0.8 meters above the ground at a 3 meter semi-anechoic chamber. The table was rotated 360 degrees to determine the position of the highest radiation.
- b. The EUT was set 3 meters away from the interference-receiving antenna, which was mounted on the top of a variable-height antenna tower.
- c. The antenna is a broadband antenna, and its height is varied from one meter to four meters above the ground to determine the maximum value of the field strength. Both horizontal and vertical polarizations of the antenna are set to make the measurement.
- d. For each suspected emission, the EUT was arranged to its worst case and then the antenna was tuned to heights from 1 meter to 4 meters and the rotatable table was turned from 0 degrees to 360 degrees to find the maximum reading.
- e. The test-receiver system was set to Peak Detect Function and Specified Bandwidth with Maximum Hold Mode.
- f. If the emission level of the EUT in peak mode was lower than the limit specified, then testing could be stopped and the peak values of the EUT would be reported. Otherwise the emissions would be re-tested one by one using peak, quasi-peak or average method as specified and then reported in a data sheet.

NOTE:

1. The resolution bandwidth and video bandwidth of test receiver/spectrum analyzer is 120kHz for Quasi-peak detection at frequency below 1GHz.
2. The resolution bandwidth and video bandwidth of test receiver/spectrum analyzer is 1 MHz for Peak detection (PK) at frequency above 1GHz.

4.2.4 DEVIATION FROM TEST STANDARD

No deviation

4.2.5 TEST SETUP

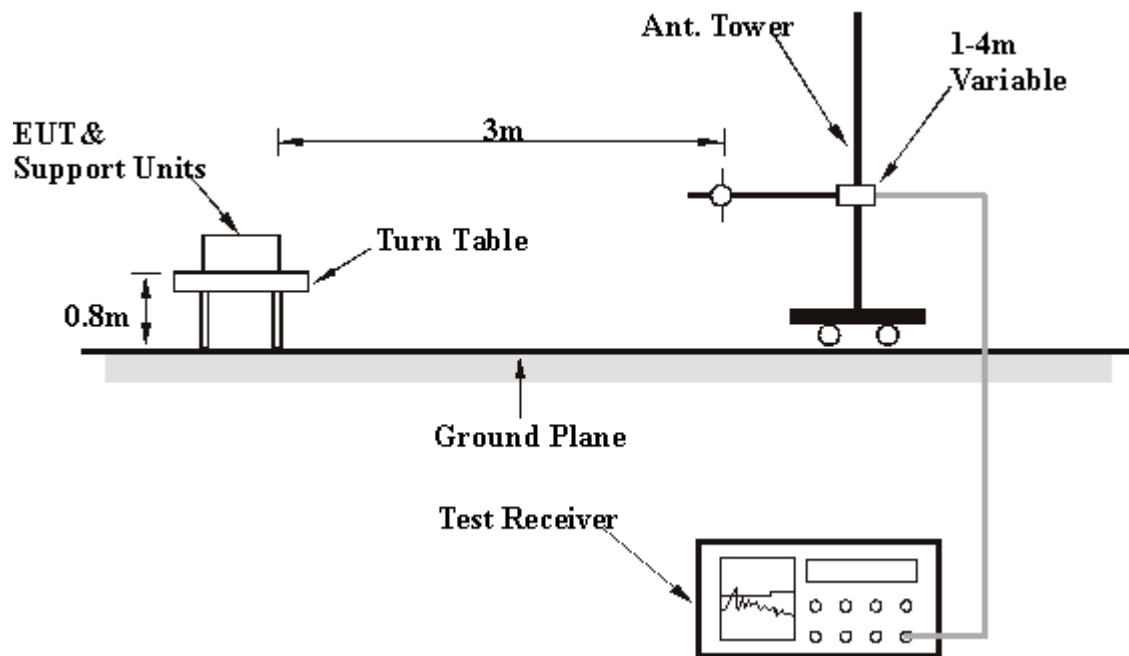

For the actual test configuration, please refer to the related item – Photographs of the Test Configuration.

4.2.6 EUT OPERATING CONDITIONS

Same as 4.1.6

4.2.7 TEST RESULTS

RADIATED WORST CASE DATA: MODE A FOR GFSK (BELOW 1GHz)

TEST MODE	A		
MODULATION TYPE	GFSK	CHANNEL	78
INPUT POWER	120Vac, 60 Hz	FREQUENCY RANGE	Below 1000MHz
ENVIRONMENTAL CONDITIONS	22deg. C, 84% RH, 1001hPa	DETECTOR FUNCTION	Quasi-Peak
TESTED BY	Jamison Chan		

ANTENNA POLARITY & TEST DISTANCE: HORIZONTAL AT 3 M

No.	Freq. (MHz)	Emission Level (dBuV/m)	Limit (dBuV/m)	Margin (dB)	Antenna Height (m)	Table Angle (Degree)	Raw Value (dBuV)	Correction Factor (dB/m)
1	125.25	32.10 QP	43.50	-11.40	1.34 H	13	20.44	11.66
2	745.35	25.24 QP	46.00	-20.76	1.88 H	286	-2.36	27.60
3	792.00	26.85 QP	46.00	-19.15	1.66 H	208	-1.16	28.00
4	840.60	27.29 QP	46.00	-18.71	1.57 H	235	-1.10	28.38
5	891.14	28.24 QP	46.00	-17.76	2.16 H	313	-1.11	29.35
6	937.80	29.86 QP	46.00	-16.14	2.11 H	202	-0.54	30.40

ANTENNA POLARITY & TEST DISTANCE: VERTICAL AT 3 M

No.	Freq. (MHz)	Emission Level (dBuV/m)	Limit (dBuV/m)	Margin (dB)	Antenna Height (m)	Table Angle (Degree)	Raw Value (dBuV)	Correction Factor (dB/m)
1	125.25	30.64 QP	43.50	-12.86	1.00 V	355	18.98	11.66
2	753.13	27.08 QP	46.00	-18.92	1.05 V	94	-0.73	27.82
3	821.16	27.36 QP	46.00	-18.64	1.09 V	166	-0.86	28.22
4	881.42	27.80 QP	46.00	-18.20	1.03 V	337	-1.34	29.14
5	935.85	29.99 QP	46.00	-16.01	2.12 V	268	-0.37	30.36
6	982.51	30.30 QP	54.00	-23.70	1.71 V	16	-0.13	30.43

- REMARKS:**
1. Emission level(dBuV/m)=Raw Value(dBuV) + Correction Factor(dB/m)
 2. Correction Factor(dB/m) = Antenna Factor (dB/m) + Cable Factor (dB)
 3. The other emission levels were very low against the limit.
 4. Margin value = Emission level – Limit value.

RADIATED WORST CASE DATA: MODE B FOR GFSK (BELOW 1GHz)

TEST MODE	B		
MODULATION TYPE	GFSK	CHANNEL	78
INPUT POWER	120Vac, 60 Hz	FREQUENCY RANGE	Below 1000MHz
ENVIRONMENTAL CONDITIONS	26deg. C, 65% RH, 978hPa	DETECTOR FUNCTION	Quasi-Peak
TESTED BY	Jamison Chan		

ANTENNA POLARITY & TEST DISTANCE: HORIZONTAL AT 3 M

No.	Freq. (MHz)	Emission Level (dBuV/m)	Limit (dBuV/m)	Margin (dB)	Antenna Height (m)	Table Angle (Degree)	Raw Value (dBuV)	Correction Factor (dB/m)
1	117.48	21.73 QP	43.50	-21.77	3.08 H	118	18.28	3.45
2	537.36	23.06 QP	46.00	-22.94	1.75 H	169	5.29	17.77
3	659.82	23.08 QP	46.00	-22.92	2.33 H	301	-0.28	23.36
4	700.64	23.83 QP	46.00	-22.17	1.77 H	289	-0.50	24.33
5	795.89	22.91 QP	46.00	-23.09	2.17 H	34	-0.99	23.89
6	830.88	33.82 QP	46.00	-12.18	3.11 H	61	9.88	23.94

ANTENNA POLARITY & TEST DISTANCE: VERTICAL AT 3 M

No.	Freq. (MHz)	Emission Level (dBuV/m)	Limit (dBuV/m)	Margin (dB)	Antenna Height (m)	Table Angle (Degree)	Raw Value (dBuV)	Correction Factor (dB/m)
1	51.38	24.55 QP	40.00	-15.45	1.63 V	10	16.65	7.90
2	84.43	17.94 QP	40.00	-22.06	1.13 V	220	14.99	2.96
3	117.48	25.85 QP	43.50	-17.65	1.00 V	172	16.41	9.44
4	539.30	22.18 QP	46.00	-23.82	1.05 V	178	4.72	17.46
5	589.84	23.45 QP	46.00	-22.55	1.17 V	214	6.22	17.23
6	830.88	29.07 QP	46.00	-16.93	1.00 V	55	3.76	25.30

- REMARKS:**
1. Emission level(dBuV/m)=Raw Value(dBuV) + Correction Factor(dB/m)
 2. Correction Factor(dB/m) = Antenna Factor (dB/m) + Cable Factor (dB)
 - 3The other emission levels were very low against the limit.
 4. Margin value = Emission level – Limit value.



RADIATED WORST CASE DATA: MODE A FOR GFSK (1 ~ 25GHz)

TEST MODE	A		
MODULATION TYPE	GFSK	CHANNEL	0
INPUT POWER	120Vac, 60 Hz	FREQUENCY RANGE	1 ~ 25GHz
ENVIRONMENTAL CONDITIONS	25deg. C, 65% RH, 993hPa	DETECTOR FUNCTION	Peak (PK) Average (AV)
TESTED BY	Jamison Chan		

ANTENNA POLARITY & TEST DISTANCE: HORIZONTAL AT 3 M

No.	Freq. (MHz)	Emission Level (dBuV/m)	Limit (dBuV/m)	Margin (dB)	Antenna Height (m)	Table Angle (Degree)	Raw Value (dBuV)	Correction Factor (dB/m)
1	2390.00	58.85 PK	74.00	-15.15	1.73 H	69	22.63	36.22
1	2390.00	47.24 AV	54.00	-6.76	1.73 H	69	11.02	36.22
2	*2402.00	101.01 PK			1.30 H	69	64.78	36.23
2	*2402.00	71.01 AV			1.30 H	69	34.78	36.23
3	4804.00	63.54 PK	74.00	-10.46	1.06 H	308	19.03	44.51
3	4804.00	33.54 AV	54.00	-20.46	1.06 H	308	-10.97	44.51

ANTENNA POLARITY & TEST DISTANCE: VERTICAL AT 3 M

No.	Freq. (MHz)	Emission Level (dBuV/m)	Limit (dBuV/m)	Margin (dB)	Antenna Height (m)	Table Angle (Degree)	Raw Value (dBuV)	Correction Factor (dB/m)
1	2390.00	59.50 PK	74.00	-14.50	1.52 V	268	23.28	36.22
1	2390.00	48.26 AV	54.00	-5.74	1.52 V	268	12.04	36.22
2	*2402.00	95.24 PK			1.52 V	268	59.01	36.23
2	*2402.00	65.24 AV			1.52 V	268	29.01	36.23
3	4804.00	65.70 PK	74.00	-8.30	1.24 V	93	21.19	44.51
3	4804.00	35.70 AV	54.00	-18.30	1.24 V	93	-8.81	44.51

- REMARKS:**
1. Emission level (dBuV/m) = Raw Value (dBuV) + Correction Factor (dB/m).
 2. Correction Factor (dB/m) = Antenna Factor (dB/m) + Cable Factor (dB).
 3. The other emission levels were very low against the limit.
 4. Margin value = Emission level – Limit value.
 5. The DH5 packet was the worse case duty cycle for a transmit dwell time on a channel, based upon bluetooth theory the transmitter is on 0.625 * 5 per 296.25 ms per channel. Therefore, the duty cycle be equal to: $20\log(3.125/100) = -30$ dB.
 6. Average value = peak reading + $20\log(\text{duty cycle})$.

TEST MODE	A		
MODULATION TYPE	GFSK	CHANNEL	39
INPUT POWER	120Vac, 60 Hz	FREQUENCY RANGE	1 ~ 25GHz
ENVIRONMENTAL CONDITIONS	25deg. C, 65% RH, 993hPa	DETECTOR FUNCTION	Peak (PK) Average (AV)
TESTED BY	Jamison Chan		

ANTENNA POLARITY & TEST DISTANCE: HORIZONTAL AT 3 M

No.	Freq. (MHz)	Emission Level (dBuV/m)	Limit (dBuV/m)	Margin (dB)	Antenna Height (m)	Table Angle (Degree)	Raw Value (dBuV)	Correction Factor (dB/m)
1	*2441.00	101.43 PK			1.02 H	160	65.11	36.32
1	*2441.00	71.43 AV			1.02 H	160	35.11	36.32
2	4882.00	65.19 PK	74.00	-8.81	1.18 H	310	20.85	44.33
2	4882.00	35.19 AV	54.00	-18.81	1.18 H	310	-9.15	44.33

ANTENNA POLARITY & TEST DISTANCE: VERTICAL AT 3 M

No.	Freq. (MHz)	Emission Level (dBuV/m)	Limit (dBuV/m)	Margin (dB)	Antenna Height (m)	Table Angle (Degree)	Raw Value (dBuV)	Correction Factor (dB/m)
1	*2441.00	96.77 PK			1.49 V	251	60.45	36.32
1	*2441.00	66.77 AV			1.49 V	251	30.45	36.32
2	4882.00	67.69 PK	74.00	-6.31	1.35 V	78	23.35	44.33
2	4882.00	37.69 AV	54.00	-16.31	1.35 V	78	-6.65	44.33

- REMARKS:**
1. Emission level (dBuV/m) = Raw Value (dBuV) + Correction Factor (dB/m).
 2. Correction Factor (dB/m) = Antenna Factor (dB/m) + Cable Factor (dB).
 3. The other emission levels were very low against the limit.
 4. Margin value = Emission level – Limit value.
 5. The DH5 packet was the worse case duty cycle for a transmit dwell time on a channel, based upon bluetooth theory the transmitter is on 0.625 * 5 per 296.25 ms per channel. Therefore, the duty cycle be equal to: $20\log(3.125/100) = -30$ dB.
 6. Average value = peak reading + $20\log(\text{duty cycle})$.

TEST MODE	A		
MODULATION TYPE	GFSK	CHANNEL	78
INPUT POWER	120Vac, 60 Hz	FREQUENCY RANGE	1 ~ 25GHz
ENVIRONMENTAL CONDITIONS	25deg. C, 65% RH, 993hPa	DETECTOR FUNCTION	Peak (PK) Average (AV)
TESTED BY	Jamison Chan		

ANTENNA POLARITY & TEST DISTANCE: HORIZONTAL AT 3 M

No.	Freq. (MHz)	Emission Level (dBuV/m)	Limit (dBuV/m)	Margin (dB)	Antenna Height (m)	Table Angle (Degree)	Raw Value (dBuV)	Correction Factor (dB/m)
1	*2480.00	99.21 PK			1.21 H	49	62.80	36.41
1	*2480.00	69.21 AV			1.21 H	49	32.80	36.41
2	2483.50	60.21 PK	74.00	-13.79	1.21 H	49	23.80	36.41
2	2483.50	47.91 AV	54.00	-6.09	1.21 H	49	11.50	36.41
3	4960.00	63.14 PK	74.00	-10.86	1.17 H	311	18.71	44.43
3	4960.00	33.14 AV	54.00	-20.86	1.17 H	311	-11.29	44.43

ANTENNA POLARITY & TEST DISTANCE: VERTICAL AT 3 M

No.	Freq. (MHz)	Emission Level (dBuV/m)	Limit (dBuV/m)	Margin (dB)	Antenna Height (m)	Table Angle (Degree)	Raw Value (dBuV)	Correction Factor (dB/m)
1	*2480.00	93.98 PK			1.16 V	325	57.57	36.41
1	*2480.00	63.98 AV			1.16 V	325	27.57	36.41
2	2483.50	60.93 PK	74.00	-13.07	1.16 V	325	24.52	36.41
2	2483.50	48.42 AV	54.00	-5.58	1.16 V	325	12.01	36.41
3	4960.00	66.27 PK	74.00	-7.73	1.29 V	69	21.84	44.43
3	4960.00	36.27 AV	54.00	-17.73	1.29 V	69	-8.16	44.43

- REMARKS:**
1. Emission level (dBuV/m) = Raw Value (dBuV) + Correction Factor (dB/m).
 2. Correction Factor (dB/m) = Antenna Factor (dB/m) + Cable Factor (dB).
 3. The other emission levels were very low against the limit.
 4. Margin value = Emission level – Limit value.
 5. The DH5 packet was the worse case duty cycle for a transmit dwell time on a channel, based upon bluetooth theory the transmitter is on 0.625 * 5 per 296.25 ms per channel. Therefore, the duty cycle be equal to: $20\log(3.125/100) = -30$ dB.
 6. Average value = peak reading + $20\log(\text{duty cycle})$.

RADIATED WORST CASE DATA: MODE A FOR 8DPSK (BELOW 1GHz)

TEST MODE	A		
MODULATION TYPE	8DPSK	CHANNEL	78
INPUT POWER	120Vac, 60 Hz	FREQUENCY RANGE	Below 1000MHz
ENVIRONMENTAL CONDITIONS	22deg. C, 84% RH, 1001hPa	DETECTOR FUNCTION	Quasi-Peak
TESTED BY	Jamison Chan		

ANTENNA POLARITY & TEST DISTANCE: HORIZONTAL AT 3 M

No.	Freq. (MHz)	Emission Level (dBuV/m)	Limit (dBuV/m)	Margin (dB)	Antenna Height (m)	Table Angle (Degree)	Raw Value (dBuV)	Correction Factor (dB/m)
1	150.52	33.90 QP	43.50	-9.60	2.13 H	217	20.23	13.68
2	776.45	26.25 QP	46.00	-19.75	1.34 H	121	-1.67	27.93
3	832.83	27.06 QP	46.00	-18.94	1.86 H	61	-1.26	28.32
4	869.76	27.72 QP	46.00	-18.28	2.04 H	130	-1.17	28.89
5	922.24	28.20 QP	46.00	-17.80	2.81 H	145	-1.85	30.05
6	955.29	29.47 QP	46.00	-16.53	1.77 H	337	-1.17	30.64

ANTENNA POLARITY & TEST DISTANCE: VERTICAL AT 3 M

No.	Freq. (MHz)	Emission Level (dBuV/m)	Limit (dBuV/m)	Margin (dB)	Antenna Height (m)	Table Angle (Degree)	Raw Value (dBuV)	Correction Factor (dB/m)
1	125.25	31.14 QP	43.50	-12.36	1.57 V	205	19.48	11.66
2	819.22	27.14 QP	46.00	-18.86	1.34 V	277	-1.06	28.20
3	848.38	26.39 QP	46.00	-19.61	1.33 V	55	-2.05	28.45
4	869.76	27.81 QP	46.00	-18.19	1.20 V	127	-1.08	28.89
5	908.64	28.72 QP	46.00	-17.28	1.31 V	97	-1.01	29.74
6	943.63	29.45 QP	46.00	-16.55	1.02 V	94	-1.08	30.53

- REMARKS:**
1. Emission level(dBuV/m)=Raw Value(dBuV) + Correction Factor(dB/m)
 2. Correction Factor(dB/m) = Antenna Factor (dB/m) + Cable Factor (dB)
 3. The other emission levels were very low against the limit.
 4. Margin value = Emission level – Limit value.

RADIATED WORST CASE DATA: MODE B FOR 8DPSK (BELOW 1GHz)

TEST MODE	B		
MODULATION TYPE	8DPSK	CHANNEL	78
INPUT POWER	120Vac, 60 Hz	FREQUENCY RANGE	Below 1000MHz
ENVIRONMENTAL CONDITIONS	26deg. C, 65% RH, 978hPa	DETECTOR FUNCTION	Quasi-Peak
TESTED BY	Jamison Chan		

ANTENNA POLARITY & TEST DISTANCE: HORIZONTAL AT 3 M

No.	Freq. (MHz)	Emission Level (dBuV/m)	Limit (dBuV/m)	Margin (dB)	Antenna Height (m)	Table Angle (Degree)	Raw Value (dBuV)	Correction Factor (dB/m)
1	121.36	21.50 QP	43.50	-22.00	3.31 H	94	17.72	3.78
2	547.07	24.56 QP	46.00	-21.44	1.66 H	151	7.99	16.57
3	663.71	23.83 QP	46.00	-22.17	1.84 H	178	0.73	23.10
4	698.70	24.16 QP	46.00	-21.84	1.37 H	301	-0.12	24.28
5	784.23	23.05 QP	46.00	-22.95	2.15 H	55	-0.79	23.84
6	825.05	24.15 QP	46.00	-21.85	1.76 H	109	0.22	23.94

ANTENNA POLARITY & TEST DISTANCE: VERTICAL AT 3 M

No.	Freq. (MHz)	Emission Level (dBuV/m)	Limit (dBuV/m)	Margin (dB)	Antenna Height (m)	Table Angle (Degree)	Raw Value (dBuV)	Correction Factor (dB/m)
1	51.38	24.98 QP	40.00	-15.02	1.00 V	310	17.08	7.90
2	82.49	17.63 QP	40.00	-22.37	1.11 V	205	14.78	2.85
3	115.53	25.85 QP	43.50	-17.65	1.23 V	190	16.87	8.98
4	582.06	22.25 QP	46.00	-23.75	1.20 V	187	5.85	16.40
5	840.60	25.93 QP	46.00	-20.07	1.25 V	148	-0.40	26.33
6	957.23	23.22 QP	46.00	-22.78	1.89 V	181	-0.73	23.95

- REMARKS:**
1. Emission level(dBuV/m)=Raw Value(dBuV) + Correction Factor(dB/m)
 2. Correction Factor(dB/m) = Antenna Factor (dB/m) + Cable Factor (dB)
 - 3The other emission levels were very low against the limit.
 4. Margin value = Emission level – Limit value.

RADIATED WORST CASE DATA: MODE A FOR 8DPSK (1 ~ 25GHz)

TEST MODE	A		
MODULATION TYPE	8DPSK	CHANNEL	0
INPUT POWER	120Vac, 60 Hz	FREQUENCY RANGE	1 ~ 25GHz
ENVIRONMENTAL CONDITIONS	25deg. C, 65% RH, 993hPa	DETECTOR FUNCTION	Peak (PK) Average (AV)
TESTED BY	Jamison Chan		

ANTENNA POLARITY & TEST DISTANCE: HORIZONTAL AT 3 M

No.	Freq. (MHz)	Emission Level (dBuV/m)	Limit (dBuV/m)	Margin (dB)	Antenna Height (m)	Table Angle (Degree)	Raw Value (dBuV)	Correction Factor (dB/m)
1	2390.00	61.28 PK	74.00	-12.72	2.02 H	261	25.06	36.22
1	2390.00	46.16 AV	54.00	-7.84	2.02 H	261	9.94	36.22
2	*2402.00	99.66 PK			2.02 H	261	63.43	36.23
2	*2402.00	69.66 AV			2.02 H	261	33.43	36.23
3	4804.00	54.35 PK	74.00	-19.65	1.44 H	286	9.84	44.51
3	4804.00	24.35 AV	54.00	-29.65	1.44 H	286	-20.16	44.51

ANTENNA POLARITY & TEST DISTANCE: VERTICAL AT 3 M

No.	Freq. (MHz)	Emission Level (dBuV/m)	Limit (dBuV/m)	Margin (dB)	Antenna Height (m)	Table Angle (Degree)	Raw Value (dBuV)	Correction Factor (dB/m)
1	2390.00	60.04 PK	74.00	-13.96	1.00 V	216	23.82	36.22
1	2390.00	46.95 AV	54.00	-7.05	1.00 V	216	10.73	36.22
2	*2402.00	99.18 PK			1.00 V	216	62.95	36.23
2	*2402.00	69.18 AV			1.00 V	216	32.95	36.23
3	4804.00	53.93 PK	74.00	-20.07	1.00 V	60	9.42	44.51
3	4804.00	23.93 AV	54.00	-30.07	1.00 V	60	-20.58	44.51

- REMARKS:**
1. Emission level (dBuV/m) = Raw Value (dBuV) + Correction Factor (dB/m).
 2. Correction Factor (dB/m) = Antenna Factor (dB/m) + Cable Factor (dB).
 3. The other emission levels were very low against the limit.
 4. Margin value = Emission level – Limit value.
 5. The DH5 packet was the worse case duty cycle for a transmit dwell time on a channel, based upon bluetooth theory the transmitter is on 0.625 * 5 per 296.25 ms per channel. Therefore, the duty cycle be equal to: $20\log(3.125/100) = -30$ dB.
 6. Average value = peak reading + $20\log(\text{duty cycle})$.

TEST MODE	A		
MODULATION TYPE	8DPSK	CHANNEL	39
INPUT POWER	120Vac, 60 Hz	FREQUENCY RANGE	1 ~ 25GHz
ENVIRONMENTAL CONDITIONS	25deg. C, 65% RH, 993hPa	DETECTOR FUNCTION	Peak (PK) Average (AV)
TESTED BY	Jamison Chan		

ANTENNA POLARITY & TEST DISTANCE: HORIZONTAL AT 3 M

No.	Freq. (MHz)	Emission Level (dBuV/m)	Limit (dBuV/m)	Margin (dB)	Antenna Height (m)	Table Angle (Degree)	Raw Value (dBuV)	Correction Factor (dB/m)
1	*2441.00	100.42 PK			1.93 H	284	64.10	36.32
1	*2441.00	70.42 AV			1.93 H	284	34.10	36.32
2	4882.00	53.77 PK	74.00	-20.23	1.84 H	240	9.43	44.33
2	4882.00	23.77 AV	54.00	-30.23	1.84 H	240	-20.57	44.33

ANTENNA POLARITY & TEST DISTANCE: VERTICAL AT 3 M

No.	Freq. (MHz)	Emission Level (dBuV/m)	Limit (dBuV/m)	Margin (dB)	Antenna Height (m)	Table Angle (Degree)	Raw Value (dBuV)	Correction Factor (dB/m)
1	*2441.00	98.73 PK			1.00 V	11	62.41	36.32
1	*2441.00	68.73 AV			1.00 V	11	32.41	36.32
2	4882.00	53.73 PK	74.00	-20.27	1.02 V	87	9.39	44.33
2	4882.00	23.73 AV	54.00	-30.27	1.02 V	87	-20.61	44.33

- REMARKS:**
1. Emission level (dBuV/m) = Raw Value (dBuV) + Correction Factor (dB/m).
 2. Correction Factor (dB/m) = Antenna Factor (dB/m) + Cable Factor (dB).
 3. The other emission levels were very low against the limit.
 4. Margin value = Emission level – Limit value.
 5. The DH5 packet was the worse case duty cycle for a transmit dwell time on a channel, based upon bluetooth theory the transmitter is on 0.625 * 5 per 296.25 ms per channel. Therefore, the duty cycle be equal to: $20\log(3.125/100) = -30$ dB.
 6. Average value = peak reading + $20\log(\text{duty cycle})$.

TEST MODE	A		
MODULATION TYPE	8DPSK	CHANNEL	78
INPUT POWER	120Vac, 60 Hz	FREQUENCY RANGE	1 ~ 25GHz
ENVIRONMENTAL CONDITIONS	25deg. C, 65% RH, 993hPa	DETECTOR FUNCTION	Peak (PK) Average (AV)
TESTED BY	Jamison Chan		

ANTENNA POLARITY & TEST DISTANCE: HORIZONTAL AT 3 M

No.	Freq. (MHz)	Emission Level (dBuV/m)	Limit (dBuV/m)	Margin (dB)	Antenna Height (m)	Table Angle (Degree)	Raw Value (dBuV)	Correction Factor (dB/m)
1	*2480.00	101.99 PK			1.22 H	219	65.58	36.41
1	*2480.00	71.99 AV			1.22 H	219	35.58	36.41
2	2483.50	61.21 PK	74.00	-12.79	1.22 H	219	24.80	36.41
2	2483.50	48.56 AV	54.00	-5.44	1.22 H	219	12.15	36.41
3	4960.00	56.03 PK	74.00	-17.97	1.21 H	220	11.60	44.43
3	4960.00	26.03 AV	54.00	-27.97	1.21 H	220	-18.40	44.43

ANTENNA POLARITY & TEST DISTANCE: VERTICAL AT 3 M

No.	Freq. (MHz)	Emission Level (dBuV/m)	Limit (dBuV/m)	Margin (dB)	Antenna Height (m)	Table Angle (Degree)	Raw Value (dBuV)	Correction Factor (dB/m)
1	*2480.00	95.78 PK			1.00 V	157	59.37	36.41
1	*2480.00	65.78 AV			1.00 V	157	29.37	36.41
2	2483.50	62.56 PK	74.00	-11.44	1.00 V	157	26.15	36.41
2	2483.50	47.79 AV	54.00	-6.21	1.00 V	157	11.38	36.41
3	4960.00	53.95 PK	74.00	-20.05	1.00 V	334	9.52	44.43
3	4960.00	23.95 AV	54.00	-30.05	1.00 V	334	-20.48	44.43

- REMARKS:**
1. Emission level (dBuV/m) = Raw Value (dBuV) + Correction Factor (dB/m).
 2. Correction Factor (dB/m) = Antenna Factor (dB/m) + Cable Factor (dB).
 3. The other emission levels were very low against the limit.
 4. Margin value = Emission level – Limit value.
 5. The DH5 packet was the worse case duty cycle for a transmit dwell time on a channel, based upon bluetooth theory the transmitter is on 0.625 * 5 per 296.25 ms per channel. Therefore, the duty cycle be equal to: $20\log(3.125/100) = -30$ dB.
 6. Average value = peak reading + $20\log(\text{duty cycle})$.



4.3 NUMBER OF HOPPING FREQUENCY USED

4.3.1 LIMIT OF HOPPING FREQUENCY USED

At least 15 channels frequencies, and should be equally spaced.

4.3.2 TEST INSTRUMENTS

DESCRIPTION & MANUFACTURER	MODEL NO.	SERIAL NO.	CALIBRATED UNTIL
SPECTRUM ANALYZER	FSP 40	100036	Mar. 16. 2007

NOTE: The calibration interval of the above test instruments is 12 months. And the calibrations are traceable to NML/ROC and NIST/USA.

4.3.3 TEST PROCEDURES

- a. Check the calibration of the measuring instrument (SA) using either an internal calibrator or a known signal from an external generator.
- b. Turn on the EUT and connect its antenna terminal to measurement via a low loss cable. Then set it to any one measured frequency within its operating range and make sure the instrument is operated in its linear range.
- c. Set the SA on MaxHold Mode, and then keep the EUT in hopping mode. Record all the signals from each channel until each one has been recorded.
- d. Set the SA on View mode and then plot the result on SA screen.
- e. Repeat above procedures until all frequencies measured were complete.

4.3.4 DEVIATION FROM TEST STANDARD

No deviation.

4.3.5 TEST SETUP

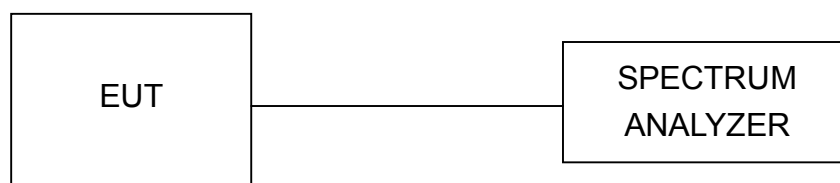

4.3.6 TEST RESULTS

There are 79 hopping frequencies in the hopping mode. Please refer to next two pages for the test result. On the plots, it shows that the hopping frequencies are equally spaced.

MODE A FOR GFSK:

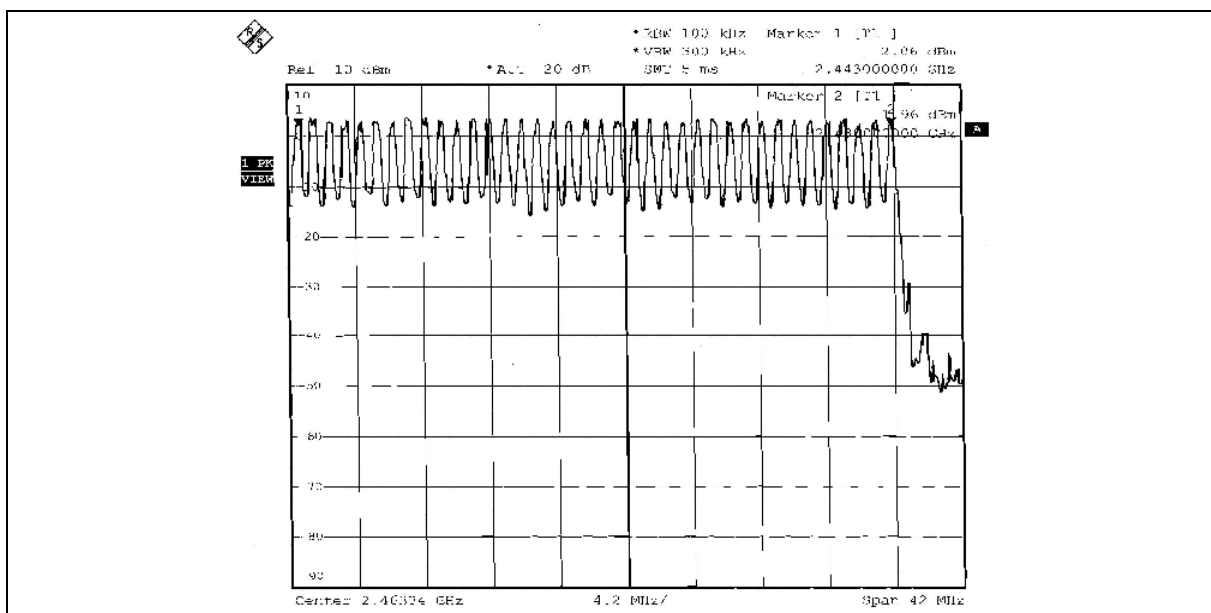
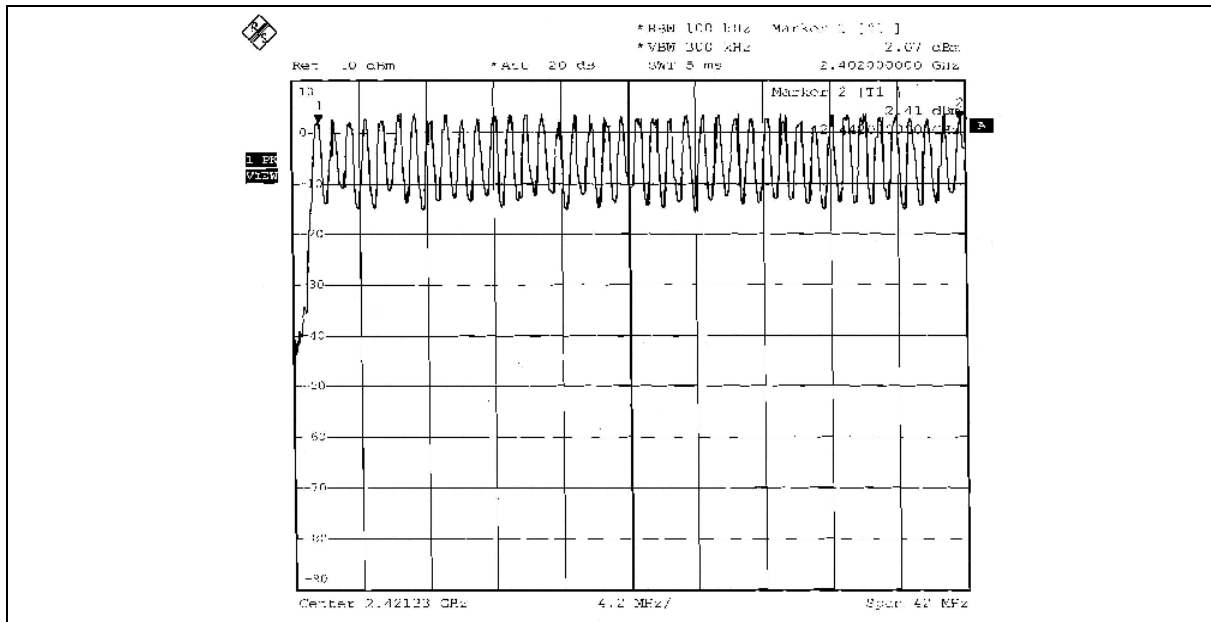

MODE A FOR 8DPSK:

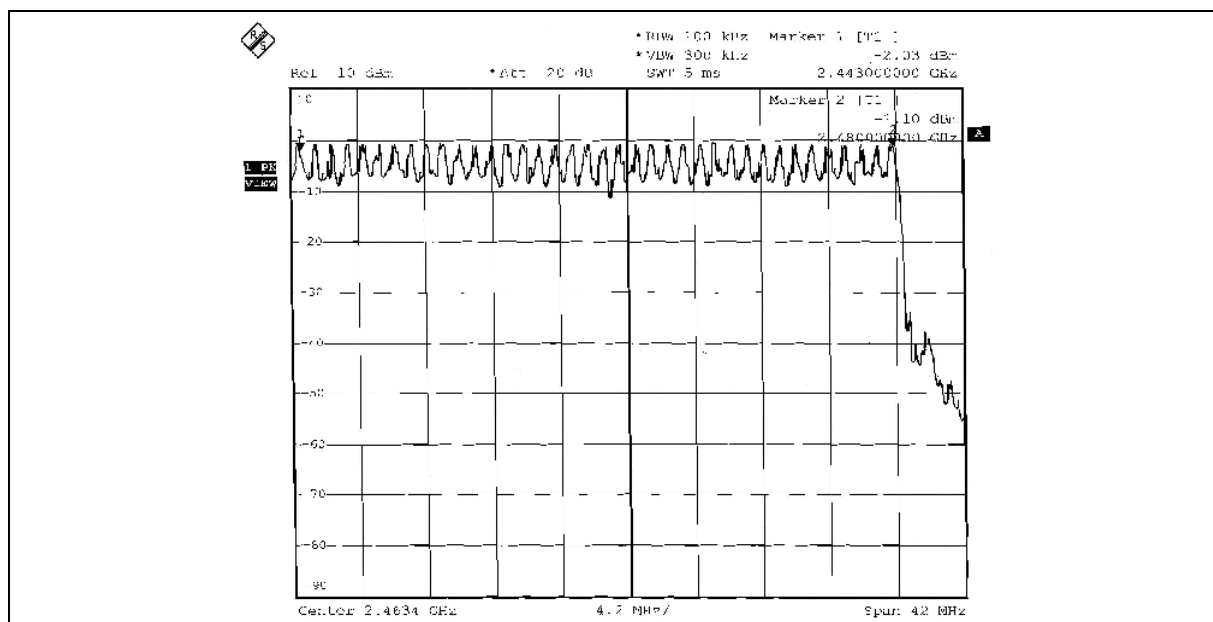
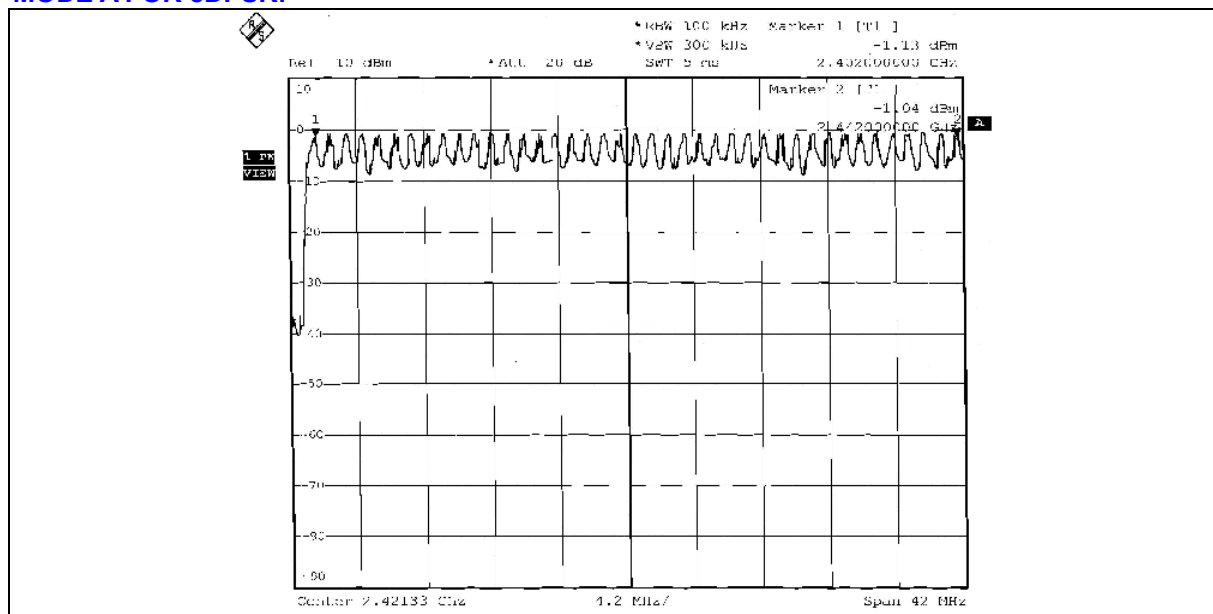

4.4 DWELL TIME ON EACH CHANNEL

4.4.1 LIMIT OF DWELL TIME USED

The average time of occupancy on any channel shall not be greater than 0.4 seconds within a period of 0.4 seconds multiplied by the number of hopping channels employed.

4.4.2 TEST INSTRUMENTS

DESCRIPTION & MANUFACTURER	MODEL NO.	SERIAL NO.	CALIBRATED UNTIL
SPECTRUM ANALYZER	FSP 40	100036	Mar. 16. 2007

NOTES: The calibration interval of the above test instruments is 12 months. And the calibrations are traceable to NML/ROC and NIST/USA.

4.4.3 TEST PROCEDURES

- a. Check the calibration of the measuring instrument (SA) using either an internal calibrator or a known signal from an external generator.
- b. Turn on the EUT and connect its antenna terminal to measurement via a low loss cable. Then set it to any one measured frequency within its operating range and make sure the instrument is operated in its linear range.
- c. Adjust the center frequency of SA on any frequency be measured and set SA to zero span mode. And then, set RBW and VBW of spectrum analyzer to proper value.
- d. Measure the time duration of one transmission on the measured frequency. And then plot the result with time difference of this time duration.
- e. Repeat above procedures until all different time-slot modes have been completed.

4.4.4 DEVIATION FROM TEST STANDARD

No deviation.

4.4.5 TEST SETUP



4.4.6 TEST RESULTS

MODE A FOR GFSK:

Mode	Number of transmission in a 31.6 (79Hopping*0.4)	Length of transmission time (msec)	Result (msec)	Limit (msec)
DH1	50 (times / 5 sec) *6.32=316.00 times	0.480	151.680	400
DH3	25 (times / 5 sec) *6.32=158.00 times	1.778	280.924	400
DH5	17 (times / 5 sec) *6.32=107.44 times	3.030	325.543	400

NOTE: Test plots of the transmitting time slot are shown on next 3 pages.

DH1

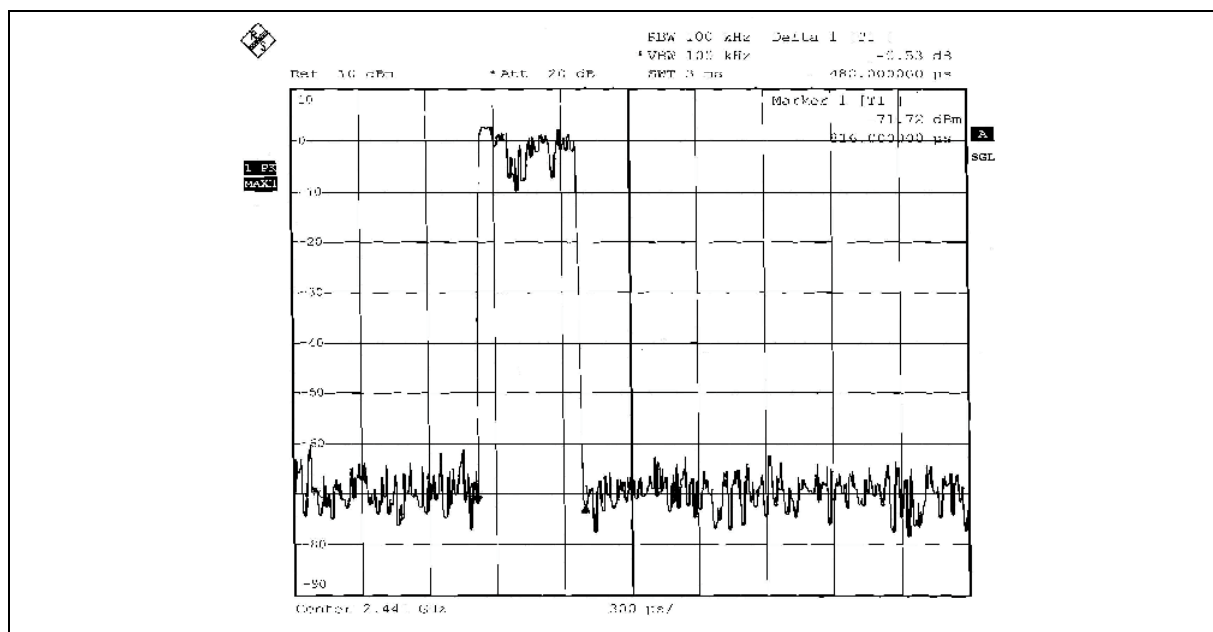
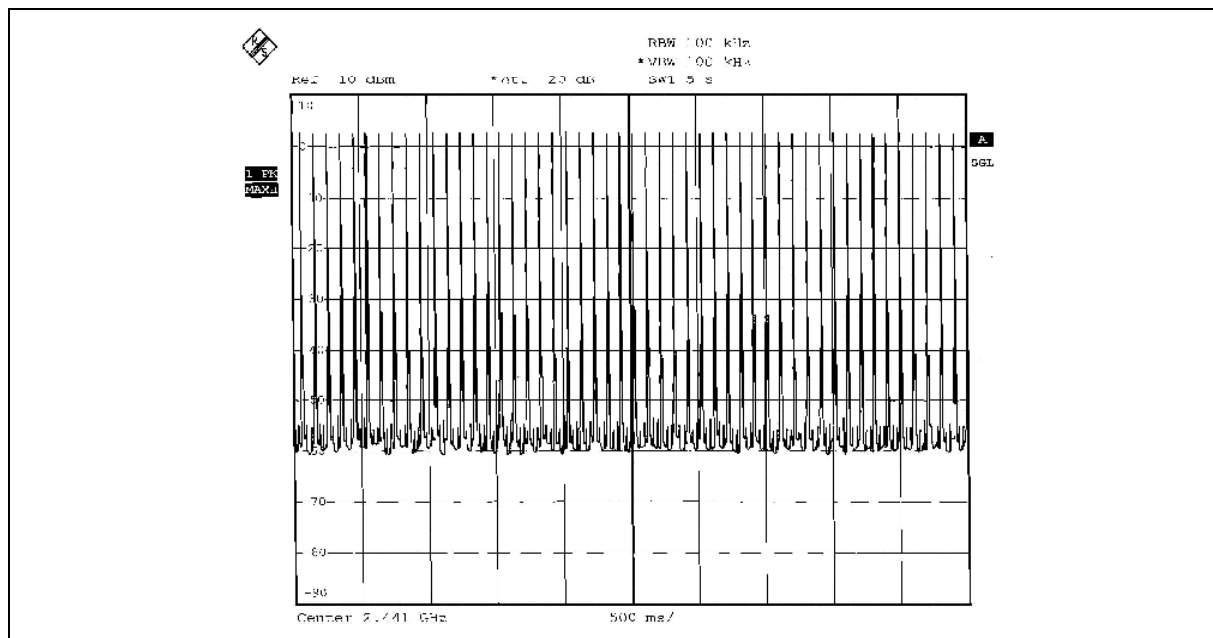

DH3

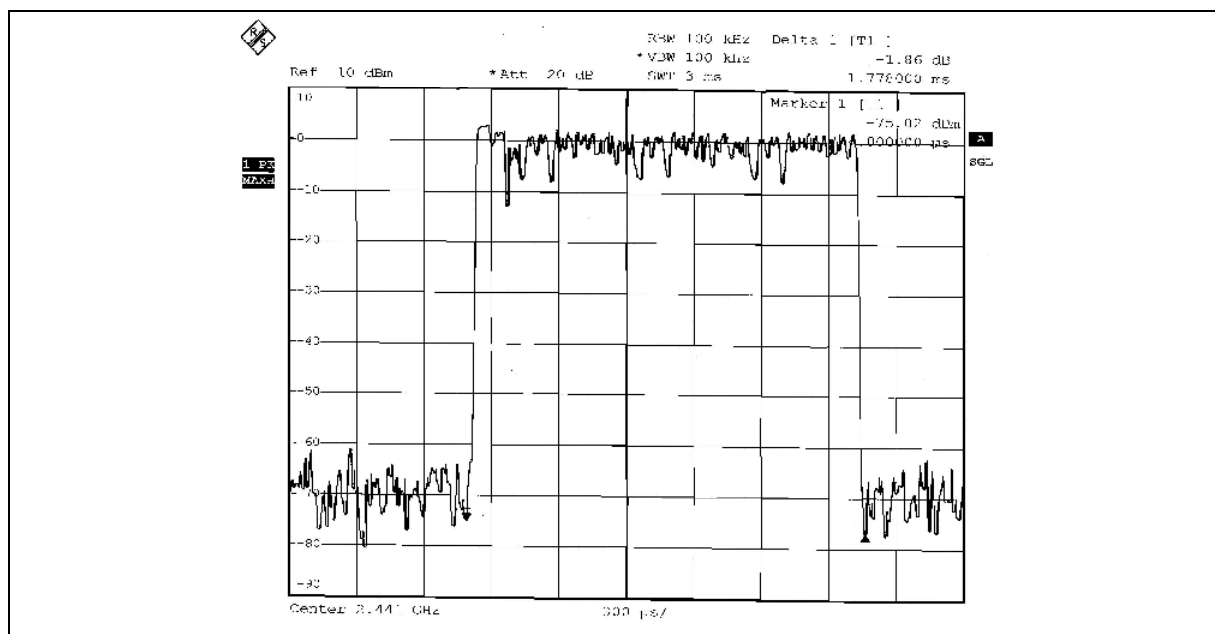
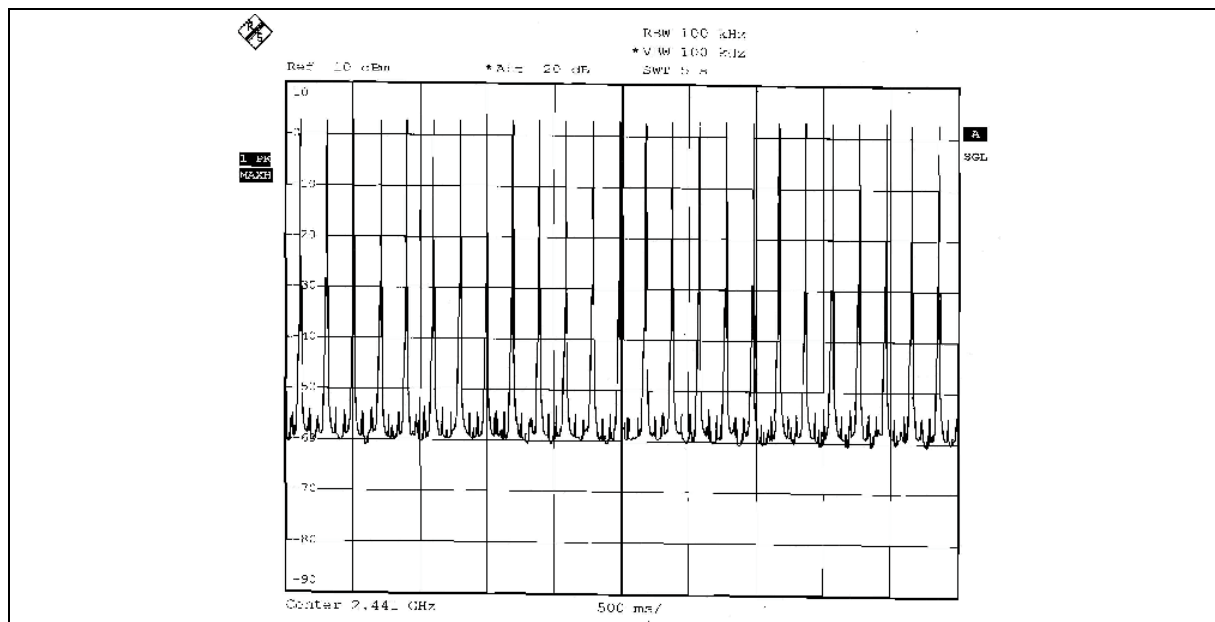

DH5

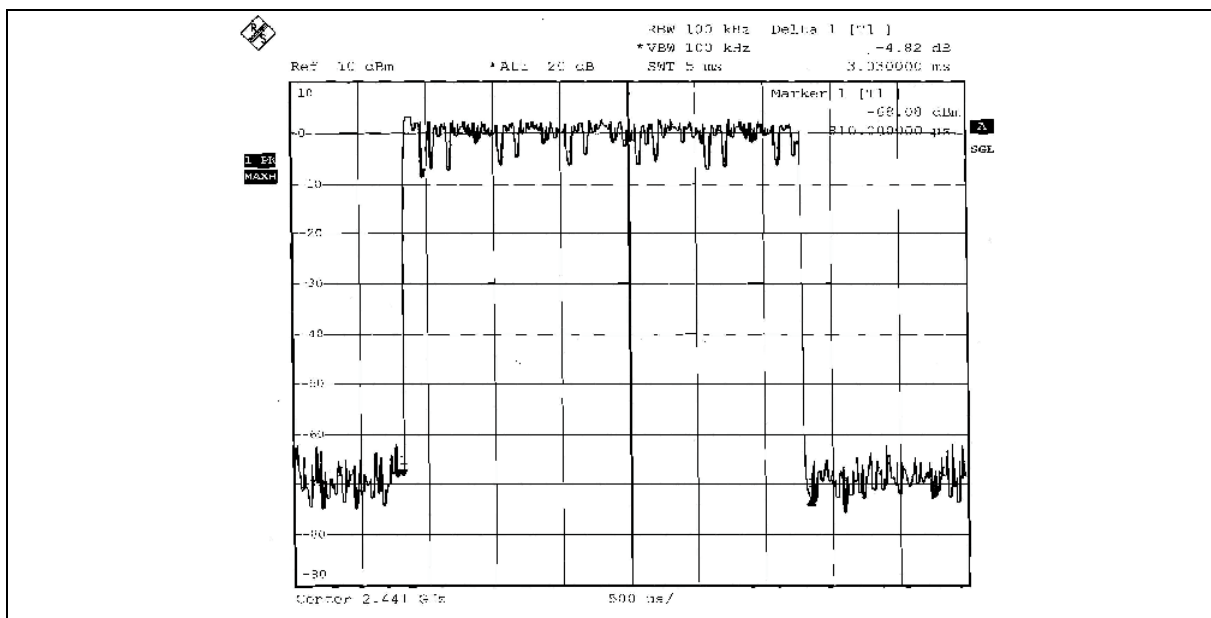
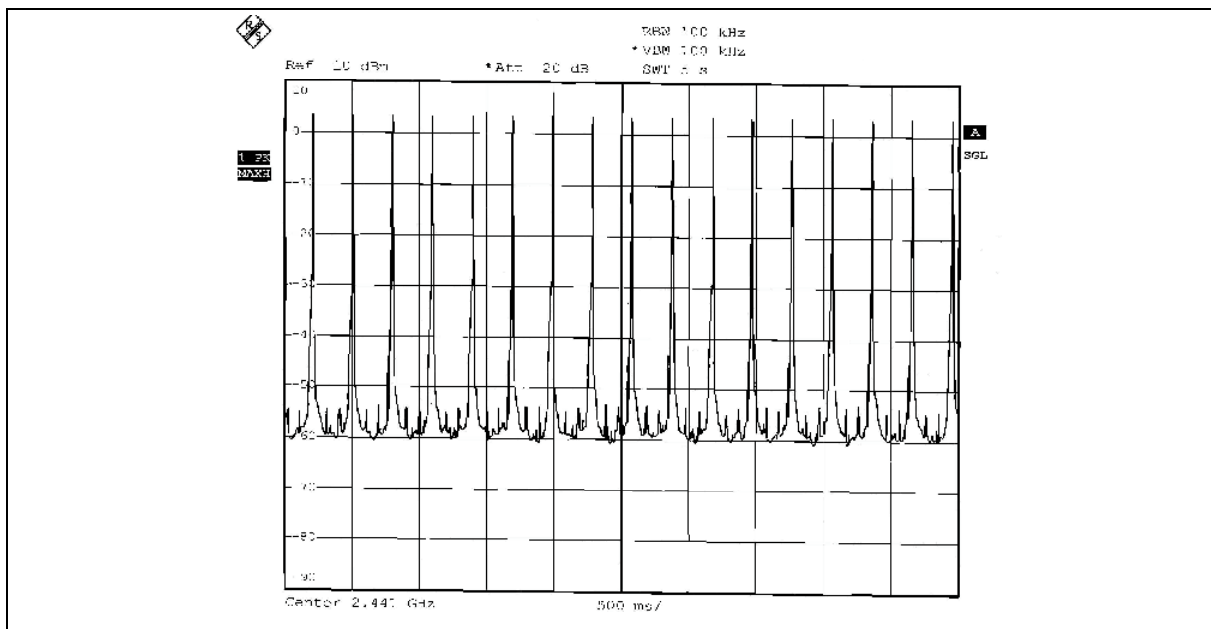



MODE A FOR 8DPSK:

Mode	Number of transmission in a 31.6 (79Hopping*0.4)	Length of transmission time (msec)	Result (msec)	Limit (msec)
DH1	51 (times / 5 sec) *6.32=322.32 times	0.504	162.4493	400
DH3	25 (times / 5 sec) *6.32=158.00 times	1.764	278.7120	400
DH5	17 (times / 5 sec) *6.32=107.44 times	3.030	325.5432	400

NOTE: Test plots of the transmitting time slot are shown on next 3 pages.

DH1

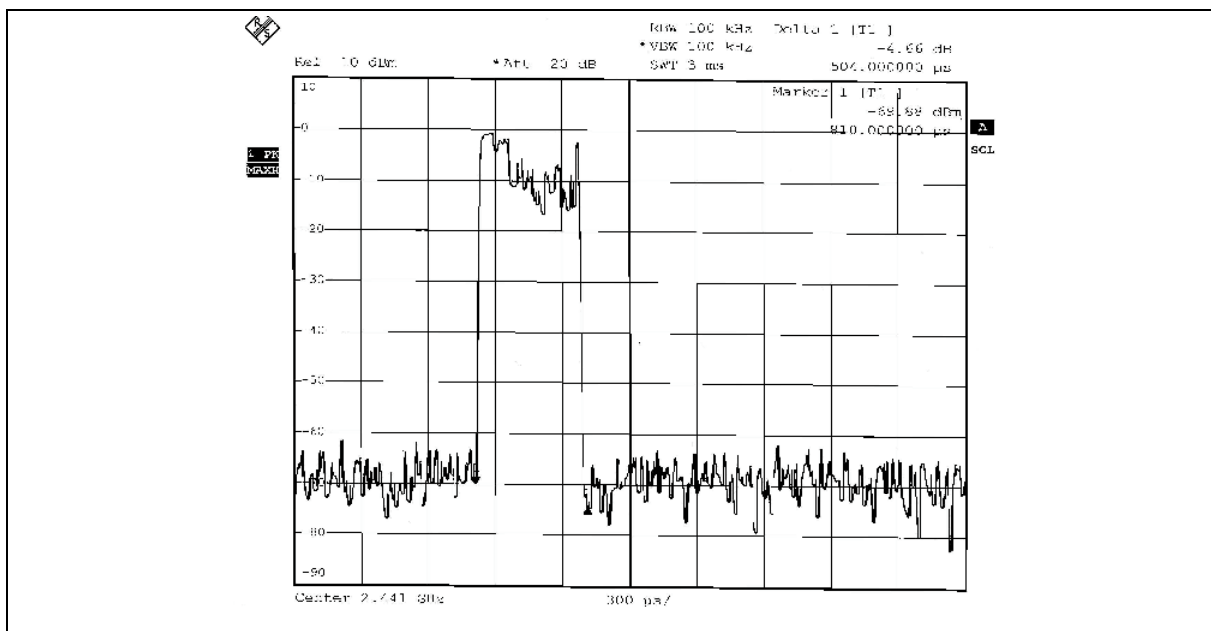
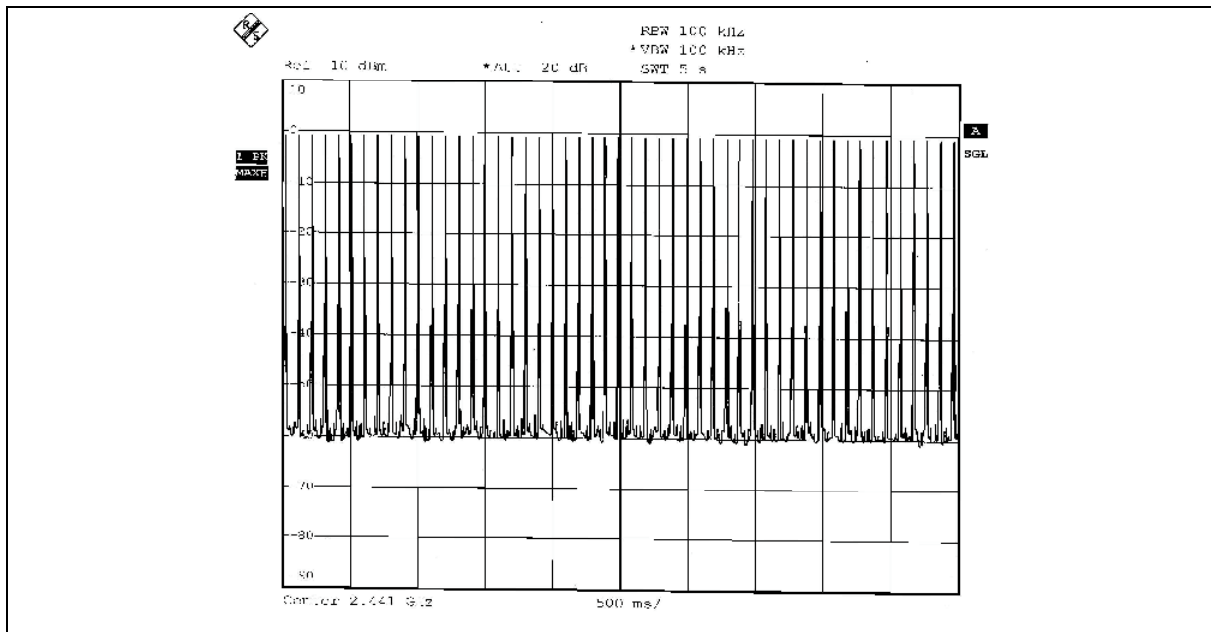

DH3

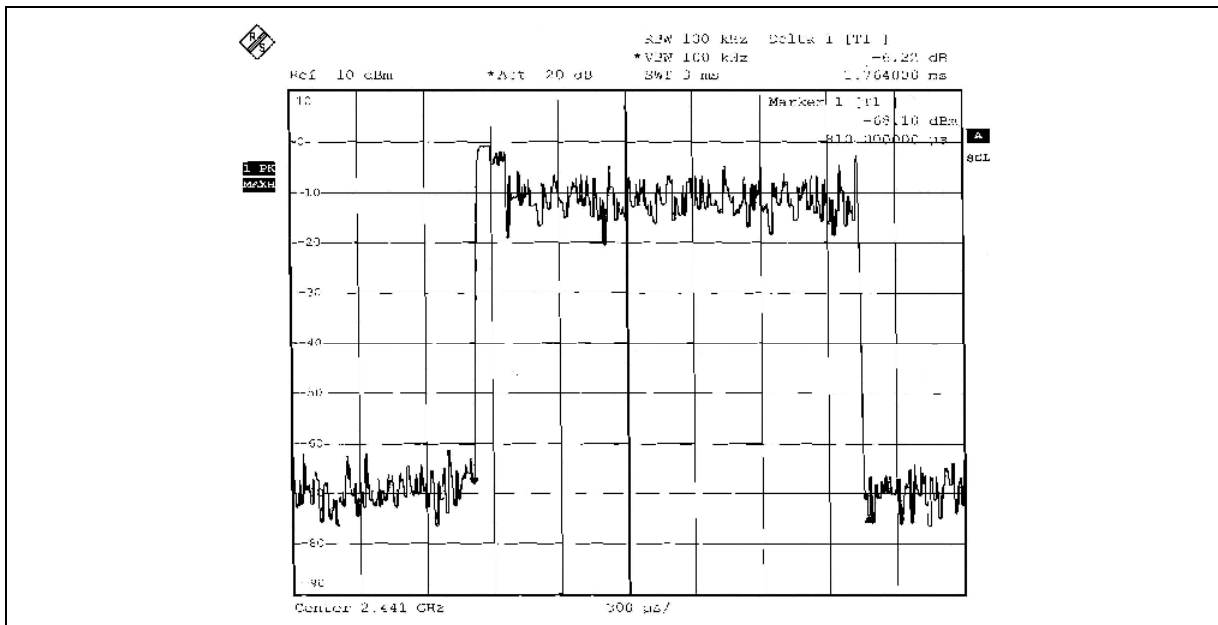
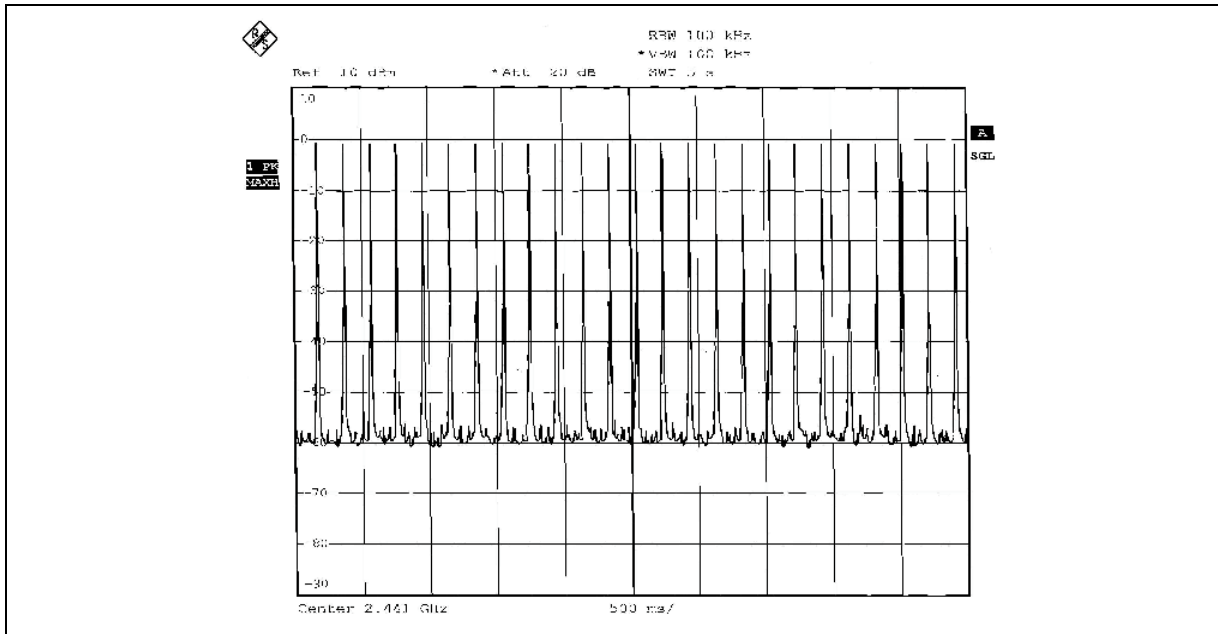

DH5

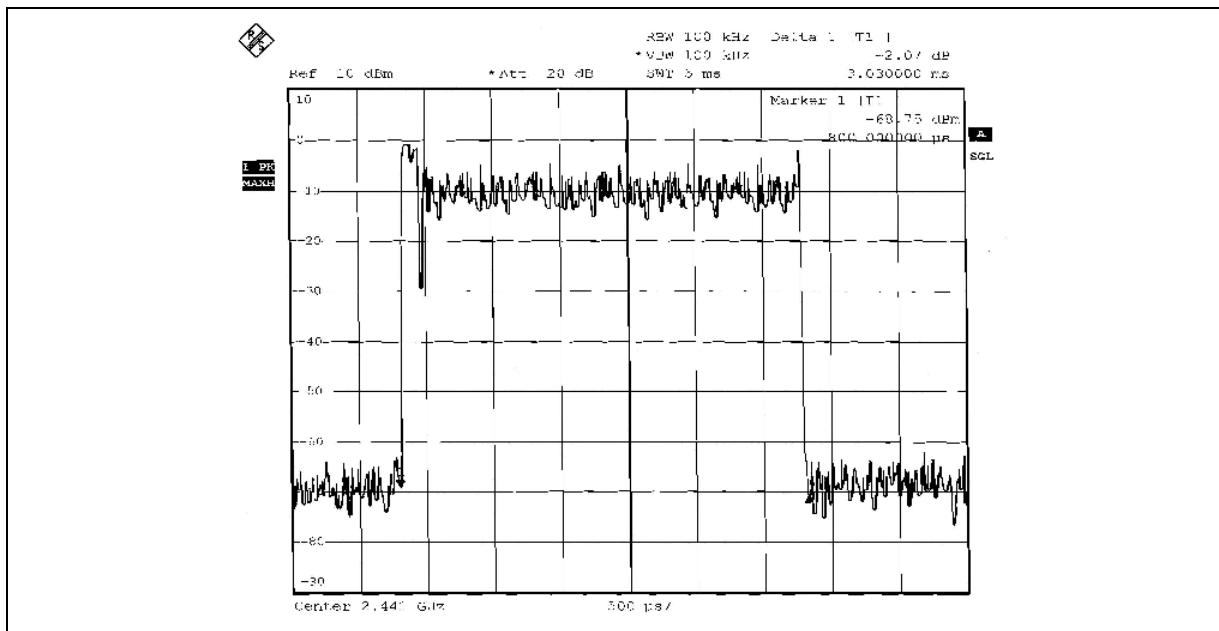
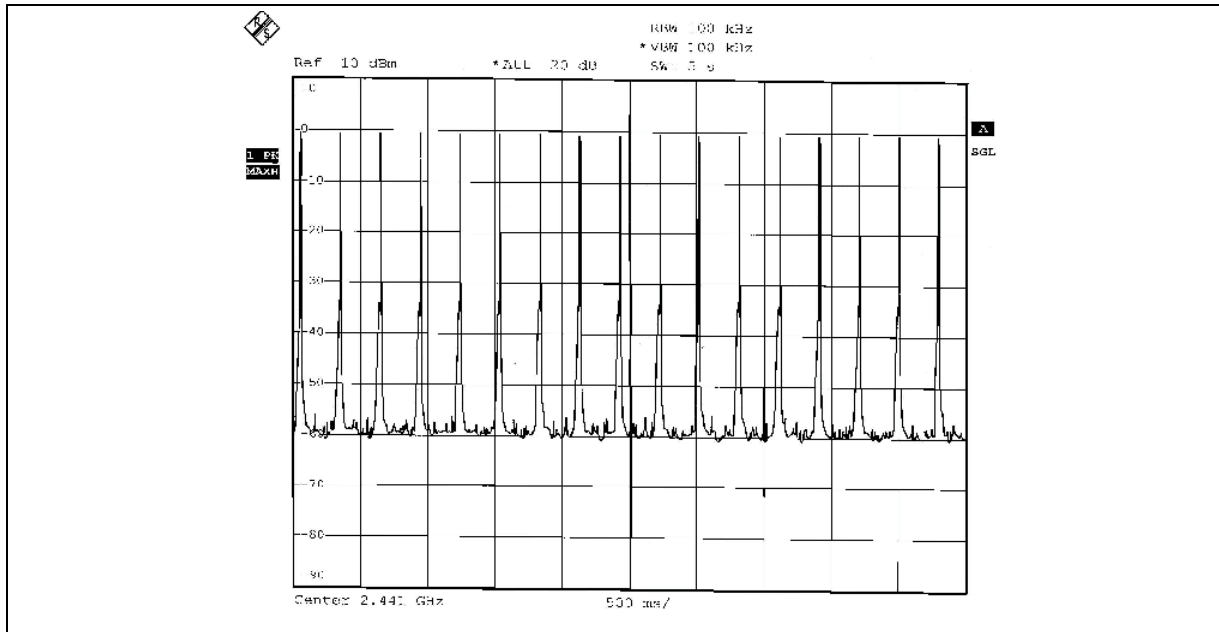



4.5 CHANNEL BANDWIDTH

4.5.1 LIMITS OF CHANNEL BANDWIDTH

For frequency hopping system operating in the 2400-2483.5MHz, If the 20dB bandwidth of hopping channel is greater than 25kHz, two-thirds 20dB bandwidth of hopping channel shall be a minimum limit for the hopping channel separation.

4.5.2 TEST INSTRUMENTS

DESCRIPTION & MANUFACTURER	MODEL NO.	SERIAL NO.	CALIBRATED UNTIL
SPECTRUM ANALYZER	FSP 40	100036	Mar. 16. 2007

NOTE: The calibration interval of the above test instruments is 12 months. And the calibrations are traceable to NML/ROC and NIST/USA.

4.5.3 TEST PROCEDURE

- a. Check the calibration of the measuring instrument using either an internal calibrator or a known signal from an external generator.
- b. Turn on the EUT and connect it to measurement instrument. Then set it to any one convenient frequency within its operating range. Set a reference level on the measuring instrument equal to the highest peak value.
- c. Measure the frequency difference of two frequencies that were attenuated 20dB from the reference level. Record the frequency difference as the emission bandwidth.
- d. Repeat above procedures until all frequencies measured were complete.

4.5.4 DEVIATION FROM TEST STANDARD

No deviation.

4.5.5 TEST SETUP



4.5.6 EUT OPERATING CONDITION

The software provided by client enabled the EUT to transmit and receive data at lowest, middle and highest channel frequencies individually.

4.5.7 TEST RESULTS

MODE A FOR GFSK:

TEST MODE	A		
MODULATION TYPE	GFSK	CHANNEL	0, 39, 78
INPUT POWER	120Vac, 60 Hz	ENVIRONMENTAL CONDITIONS	26deg. C, 66% RH, 989hPa
TESTED BY	Jamison Chan		

CHANNEL	CHANNEL FREQUENCY (MHz)	20dB BANDWIDTH (MHz)
0	2402	0.837
39	2441	0.837
78	2480	0.837

CH 0

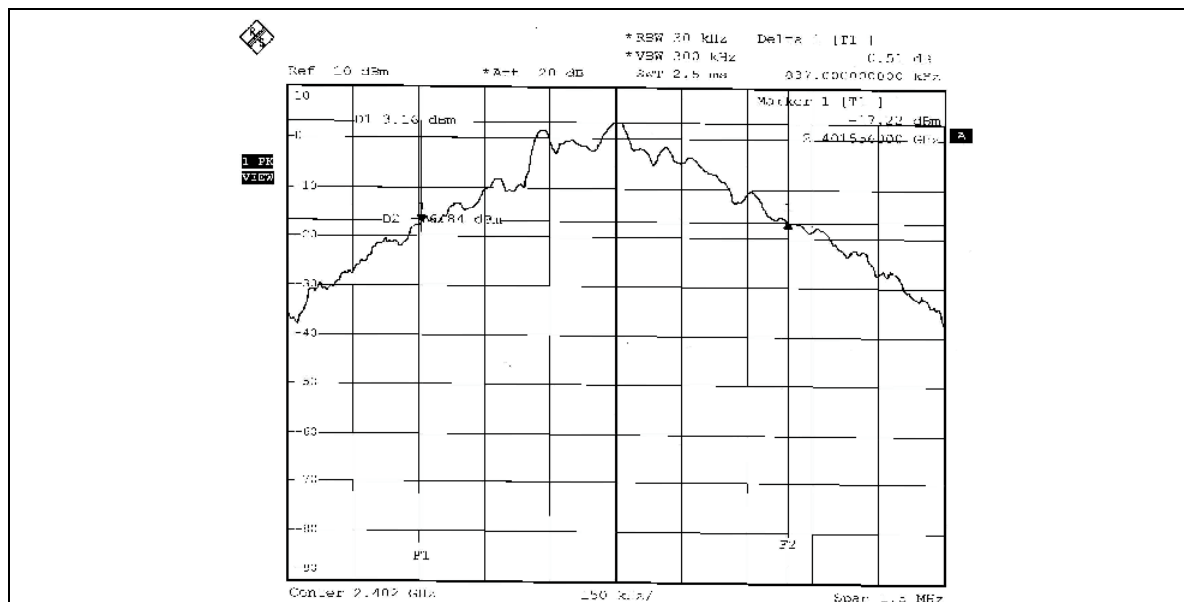

CH 39

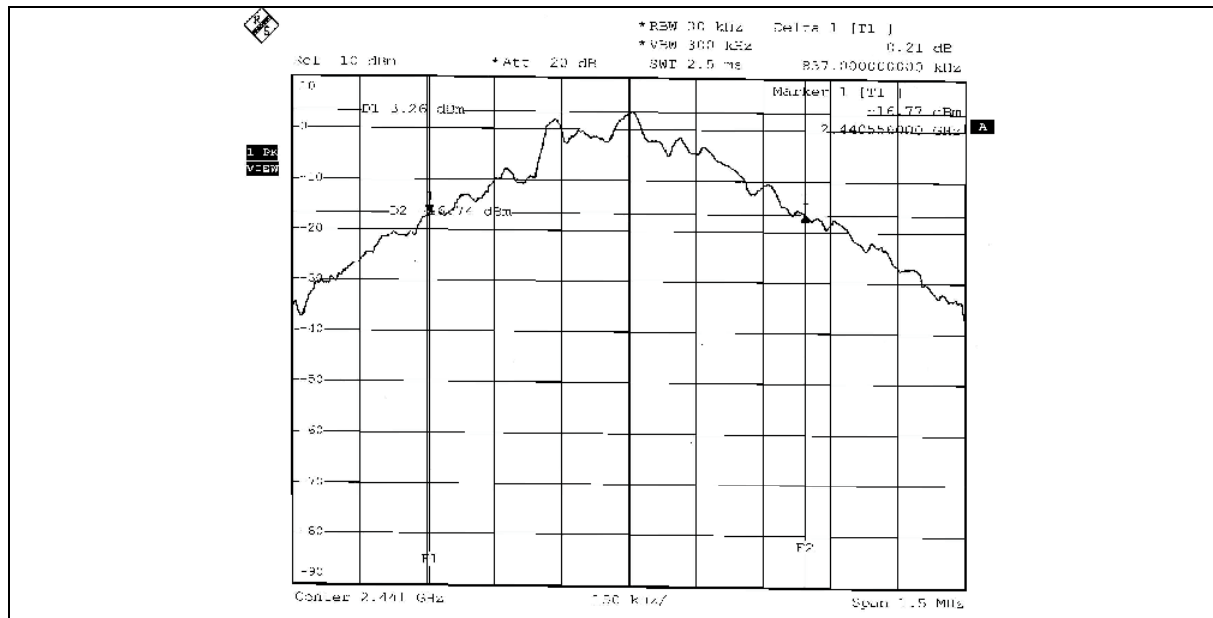

CH 78

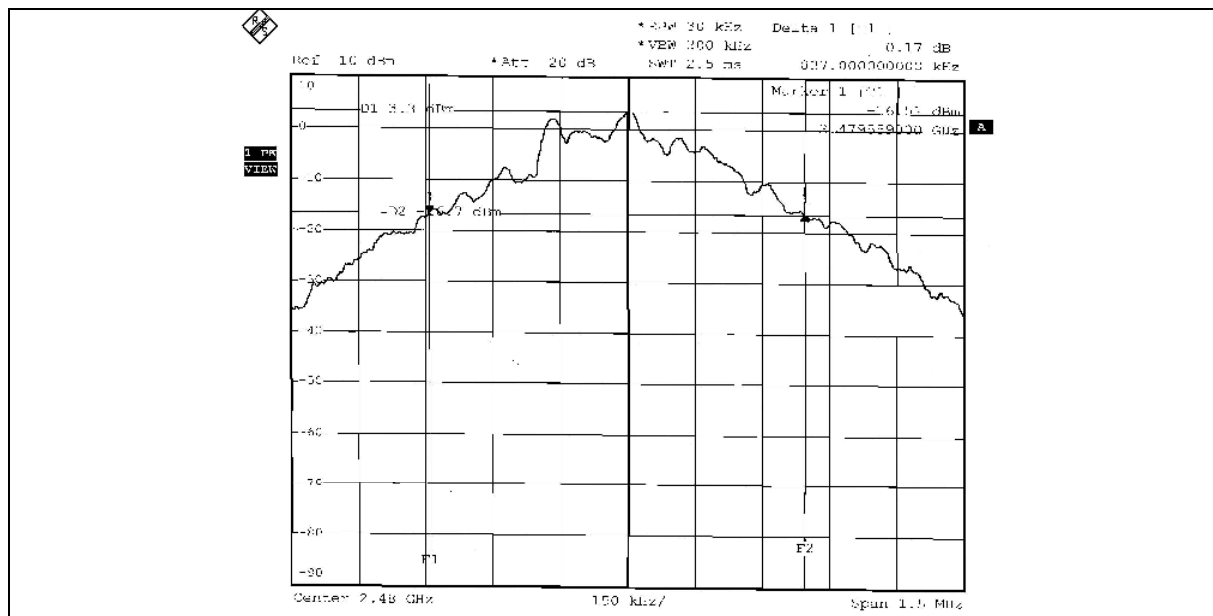

MODE A FOR 8DPSK:

TEST MODE	A		
MODULATION TYPE	8DPSK	CHANNEL	0, 39, 78
INPUT POWER	120Vac, 60 Hz	ENVIRONMENTAL CONDITIONS	26deg. C, 66% RH, 989hPa
TESTED BY	Jamison Chan		

CHANNEL	CHANNEL FREQUENCY (MHz)	20dB BANDWIDTH (MHz)
0	2402	1.263
39	2441	1.263
78	2480	1.272

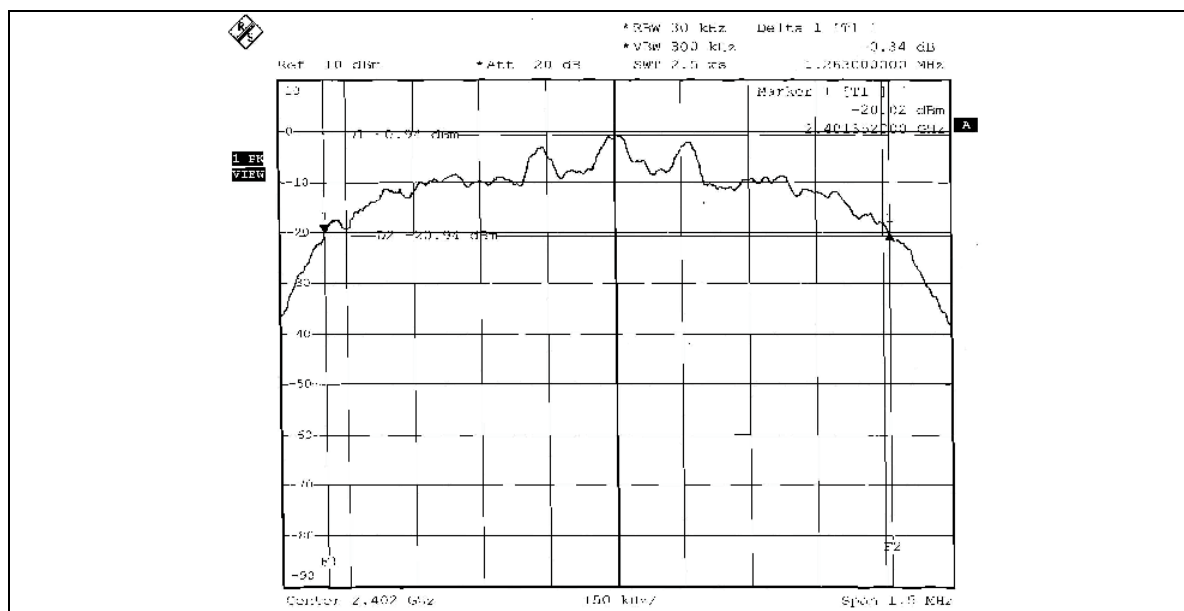
CH 0

CH 39

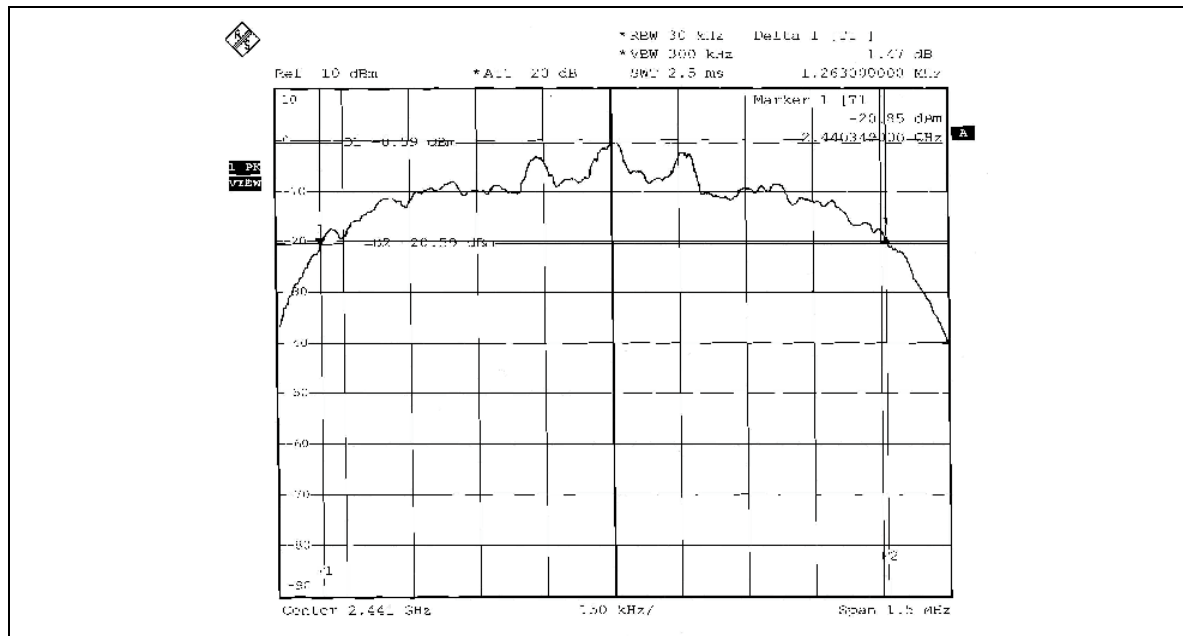

CH 78

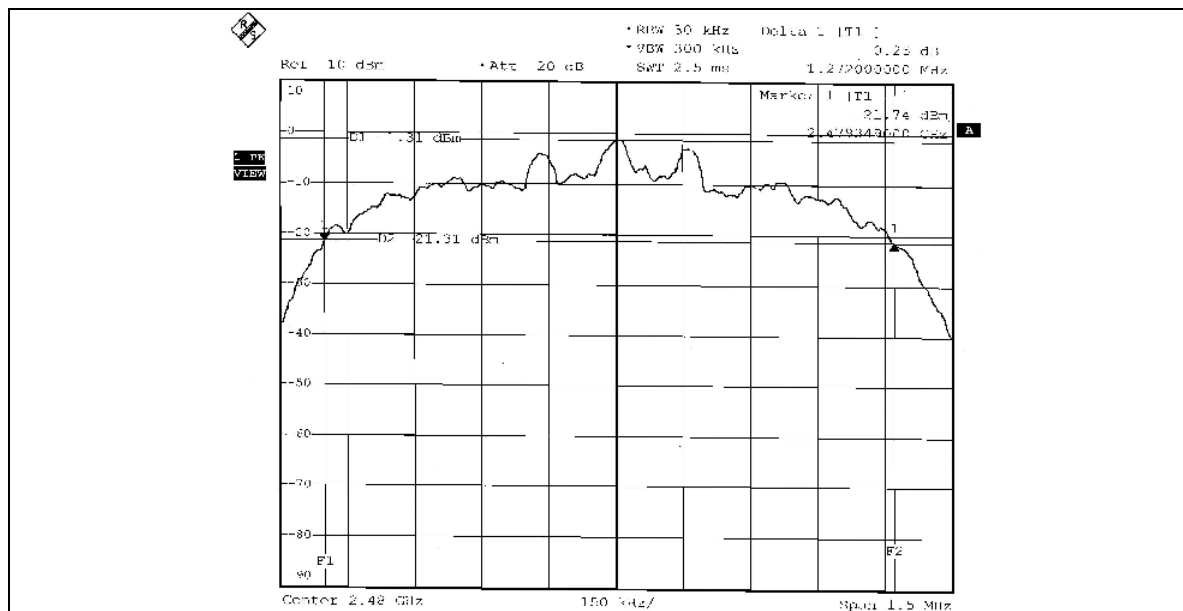



4.6 HOPPING CHANNEL SEPARATION

4.6.1 LIMIT OF HOPPING CHANNEL SEPARATION

At least 25kHz or two-third of 20dB hopping channel bandwidth (whichever is greater).

4.6.2 TEST INSTRUMENTS

DESCRIPTION & MANUFACTURER	MODEL NO.	SERIAL NO.	CALIBRATED UNTIL
SPECTRUM ANALYZER	FSP 40	100036	Mar. 16. 2007

NOTES: The calibration interval of the above test instruments is 12 months. And the calibrations are traceable to NML/ROC and NIST/USA.

4.6.3 TEST PROCEDURES

1. Check the calibration of the measuring instrument using either an internal calibrator or a known signal from an external generator.
2. Turn on the EUT and connect it to measurement instrument. Then set it to any one convenient frequency within its operating range.
3. By using the MaxHold function record the separation of two adjacent channels.
4. Measure the frequency difference of these two adjacent channels by SA MARK function. And then plot the result on SA screen.
5. Repeat above procedures until all frequencies measured were complete.

4.6.4 DEVIATION FROM TEST STANDARD

No deviation.

4.6.5 TEST SETUP



4.6.6 TEST RESULTS

MODE A FOR GFSK:

TEST MODE	A		
MODULATION TYPE	GFSK	CHANNEL	0, 39, 78
INPUT POWER	120Vac, 60 Hz	ENVIRONMENTAL CONDITIONS	26deg. C, 66% RH, 989hPa
TESTED BY	Jamison Chan		

CHANNEL	FREQUENCY (MHz)	ADJACENT CHANNEL SEPARATION (MHz)	20dB BANDWIDTH (MHz)	MINIMUM LIMIT (MHz)	PASS / FAIL
0	2402	1.000	0.837	0.558	PASS
39	2441	1.175	0.837	0.558	PASS
78	2480	1.000	0.837	0.558	PASS

NOTE: The minimum limit is two-third of 20dB bandwidth. Test results please refer to below.

CH 0

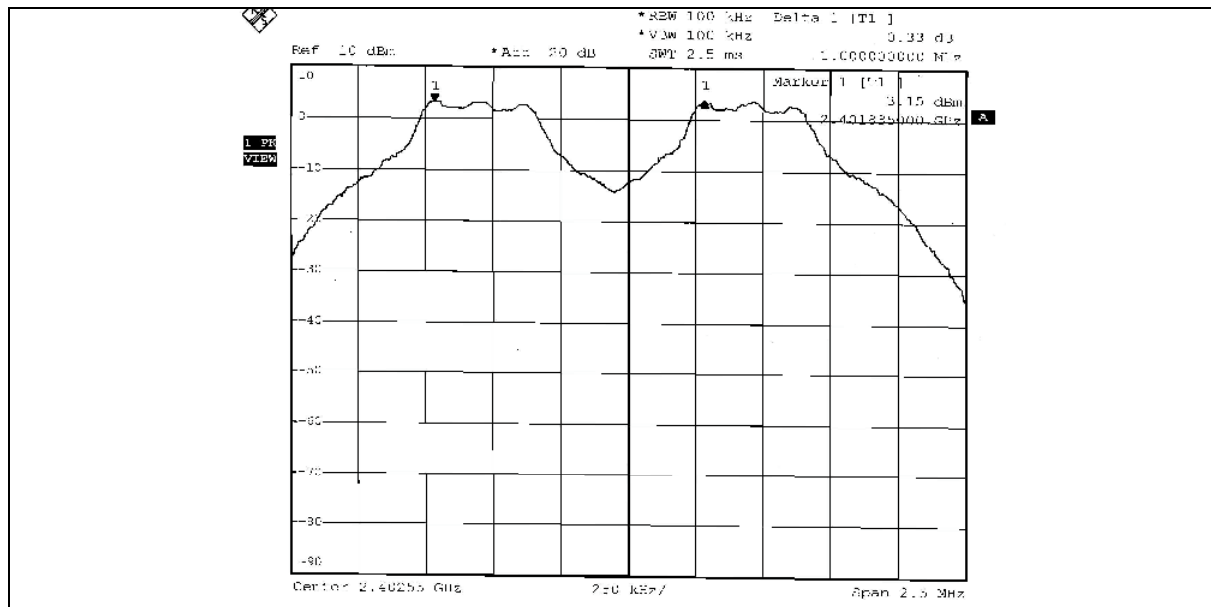

CH 39

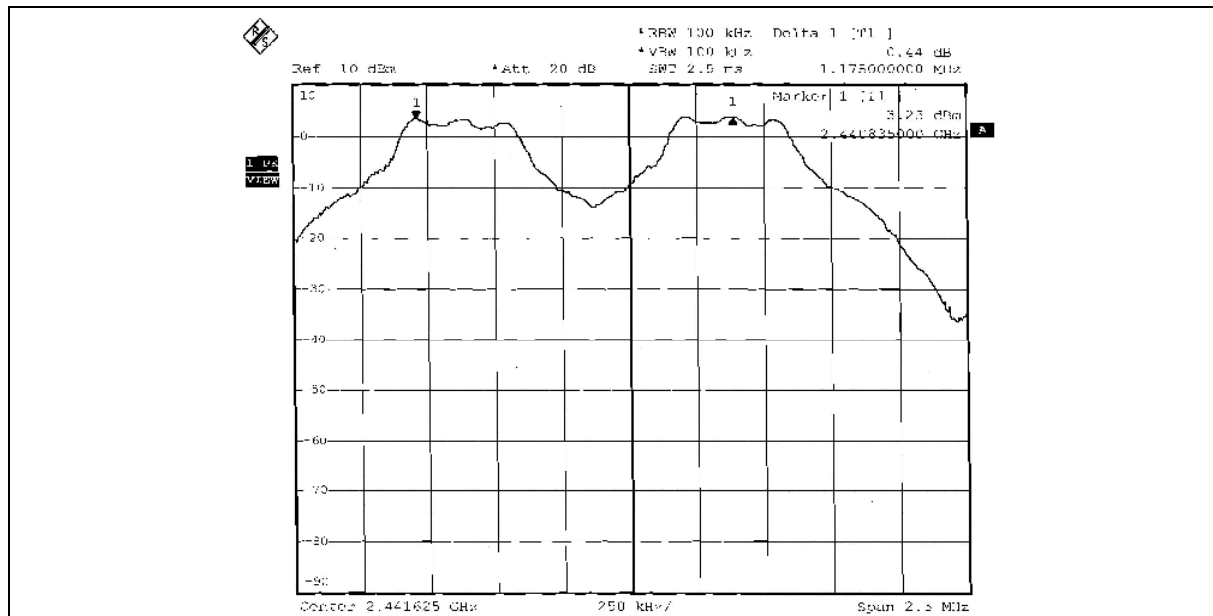

CH 78

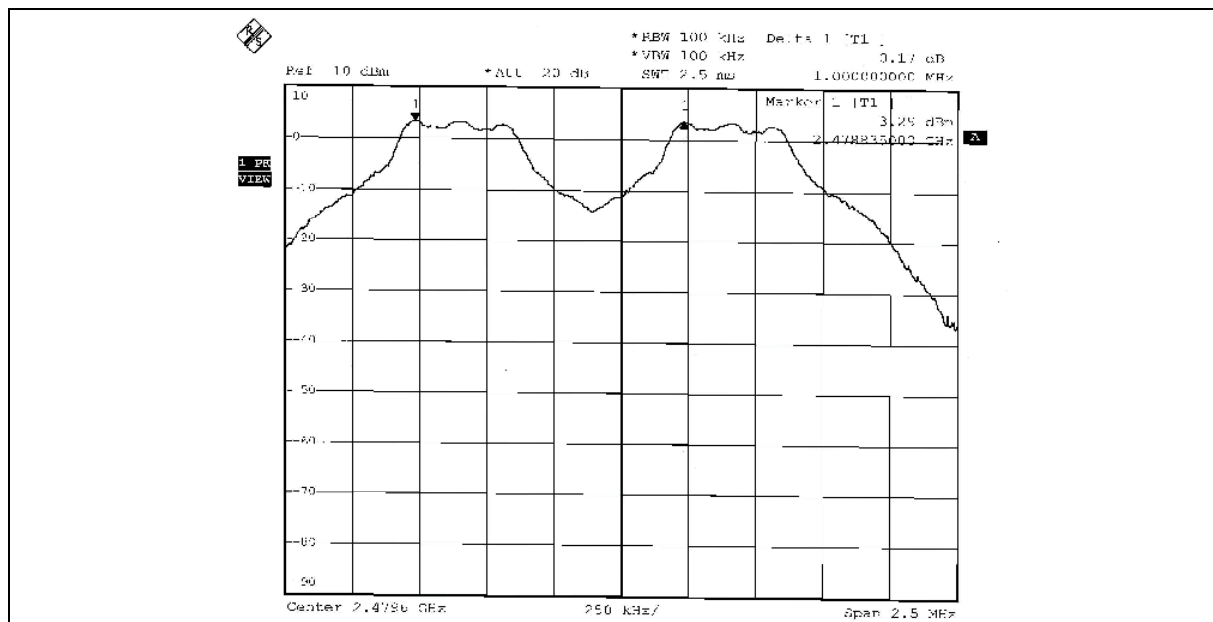



MODE A FOR 8DPSK:

TEST MODE	A		
MODULATION TYPE	8DPSK	CHANNEL	0, 39, 78
INPUT POWER	120Vac, 60 Hz	ENVIRONMENTAL CONDITIONS	26deg. C, 66% RH, 989hPa
TESTED BY	Jamison Chan		

CHANNEL	FREQUENCY (MHz)	ADJACENT CHANNEL SEPARATION (MHz)	20dB BANDWIDTH (MHz)	MINIMUM LIMIT (MHz)	PASS / FAIL
0	2402	1.005	1.263	0.842	PASS
39	2441	1.005	1.263	0.842	PASS
78	2480	1.000	1.272	0.848	PASS

NOTE: The minimum limit is two-third of 20dB bandwidth. Test results please refer to below.

CH 0

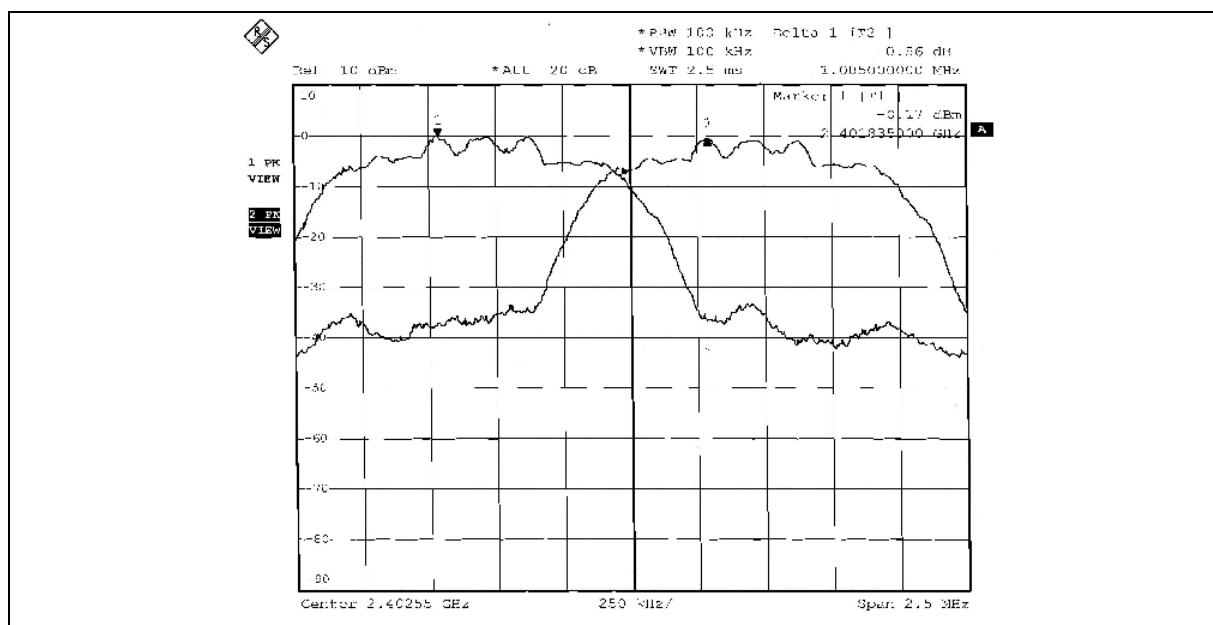

CH 39

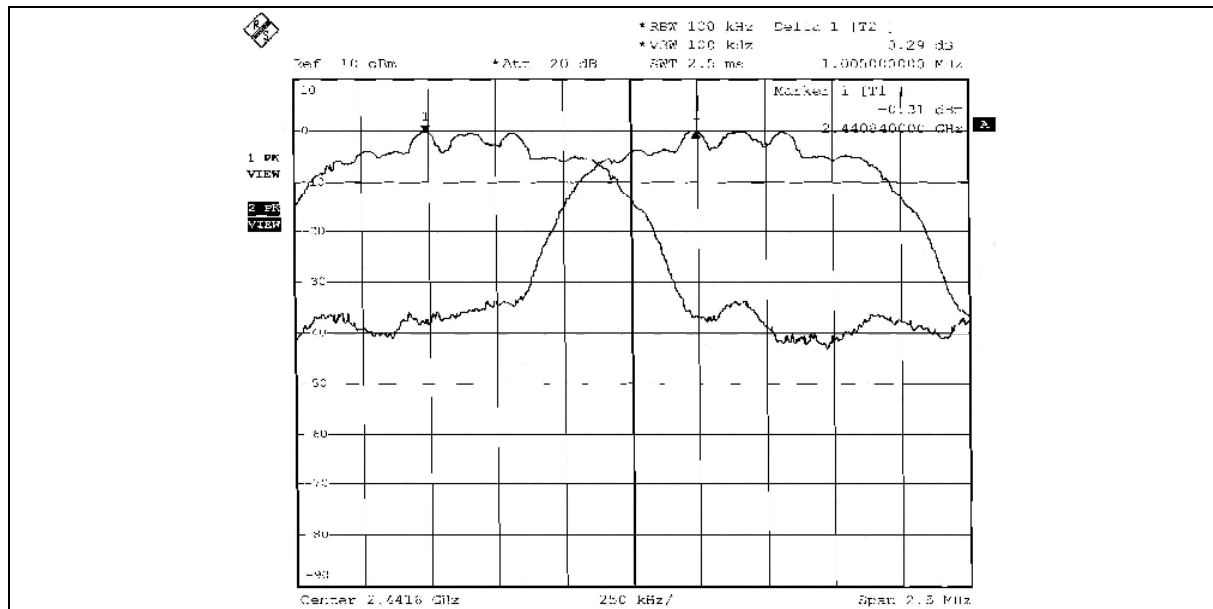

CH 78

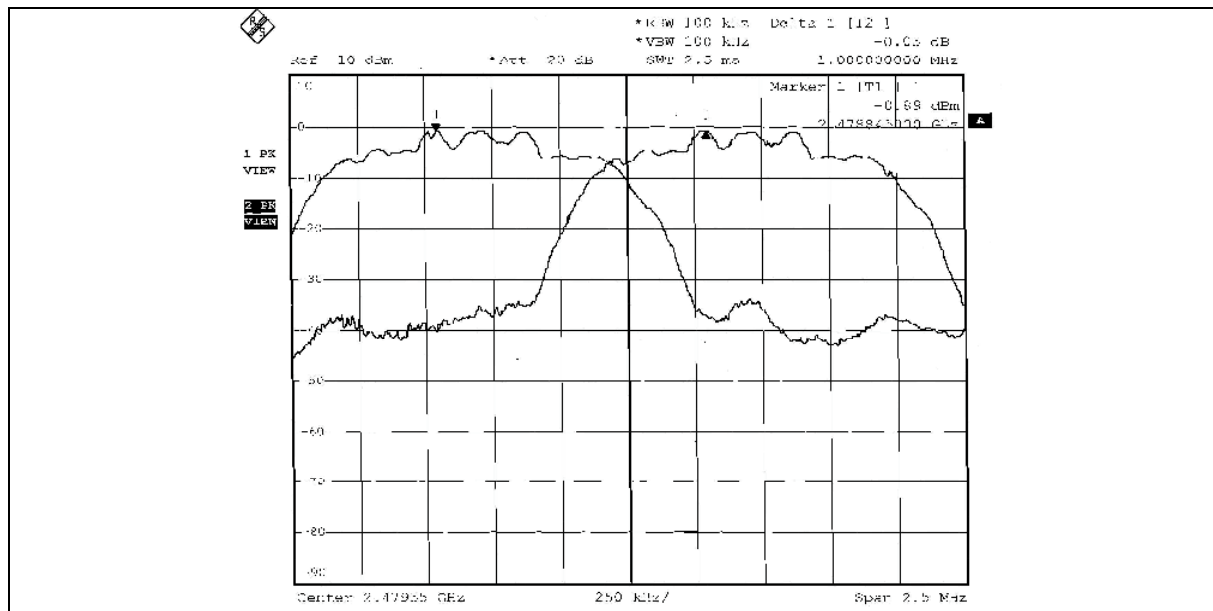



4.7 MAXIMUM PEAK OUTPUT POWER

4.7.1 LIMITS OF MAXIMUM PEAK OUTPUT POWER MEASUREMENT

The Maximum Peak Output Power Measurement is 125mW.

4.7.2 TEST INSTRUMENTS

DESCRIPTION & MANUFACTURER	MODEL NO.	SERIAL NO.	CALIBRATED UNTIL
SPECTRUM ANALYZER	FSP 40	100036	Mar. 16. 2007

NOTE: The calibration interval of the above test instruments is 12 months and the calibrations are traceable to NML/ROC and NIST/USA.

4.7.3 TEST PROCEDURES

- a. Check the calibration of the measuring instrument using either an internal calibrator or a known signal from an external generator.
- b. Turn on the EUT and connect it to measurement instrument. Then set it to any one convenient frequency within its operating range. Set a reference level on the measuring instrument equal to the highest peak value.
- c. The center frequency of the spectrum analyzer is set to the fundamental frequency and using 3 MHz RBW and 10 MHz VBW.
- d. Measure the captured power within the band and recording the plot.
- e. Repeat above procedures until all frequencies required were complete.

4.7.4 DEVIATION FROM TEST STANDARD

No deviation

4.7.5 TEST SETUP

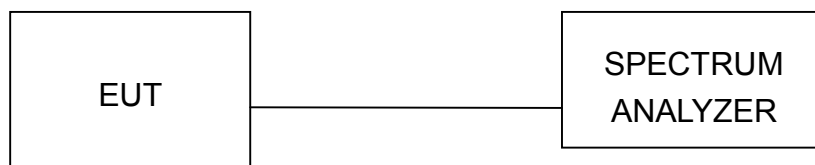

For the actual test configuration, please refer to the related Item – Photographs of the Test Configuration.

4.7.6 EUT OPERATING CONDITION

The software provided by client enabled the EUT to transmit and receive data at lowest, middle and highest channel frequencies individually.

4.7.7 TEST RESULTS

MODE A FOR GFSK:

TEST MODE	A		
MODULATION TYPE	GFSK	CHANNEL	0, 39, 78
INPUT POWER	120Vac, 60 Hz	ENVIRONMENTAL CONDITIONS	26deg. C, 66% RH, 989hPa
TESTED BY	Jamison Chan		

CHANNEL	CHANNEL FREQUENCY (MHz)	PEAK POWER OUTPUT (mW)	PEAK POWER OUTPUT (dBm)	PEAK POWER LIMIT (mW)	PASS/FAIL
0	2402	2.056	3.13	125	PASS
39	2441	2.042	3.10	125	PASS
78	2480	2.099	3.22	125	PASS

CH 0

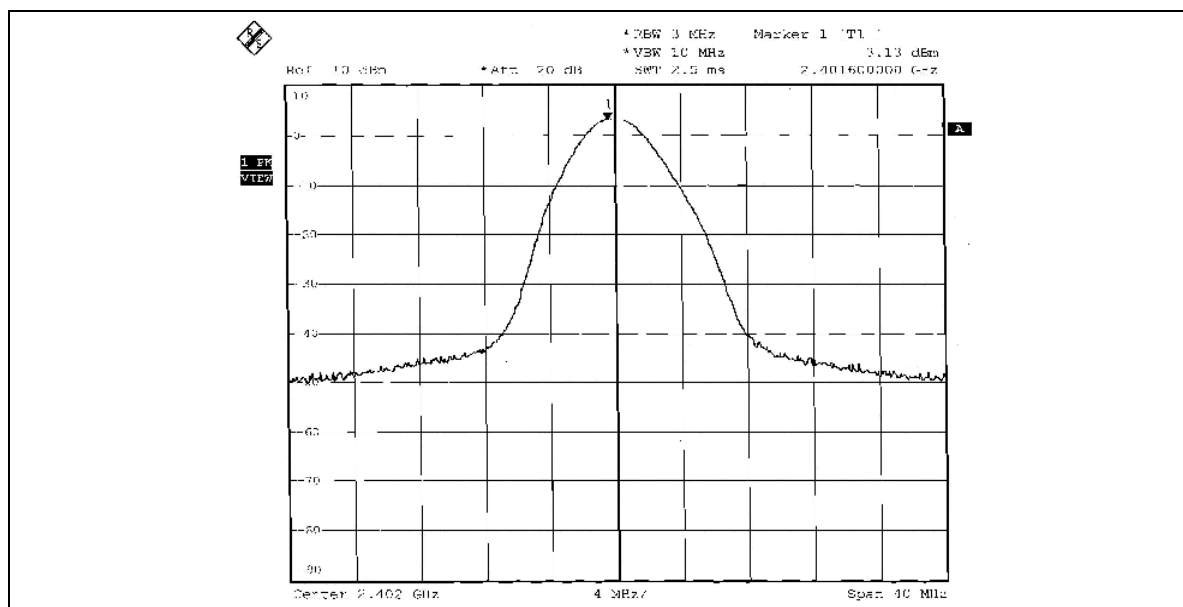

CH 39

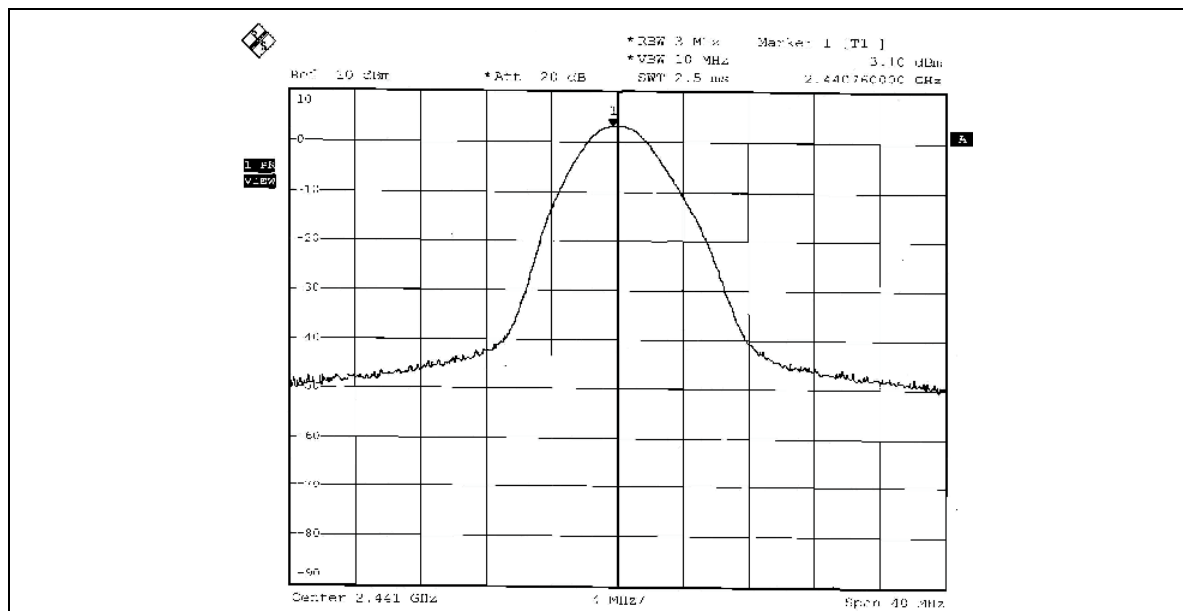

CH 78

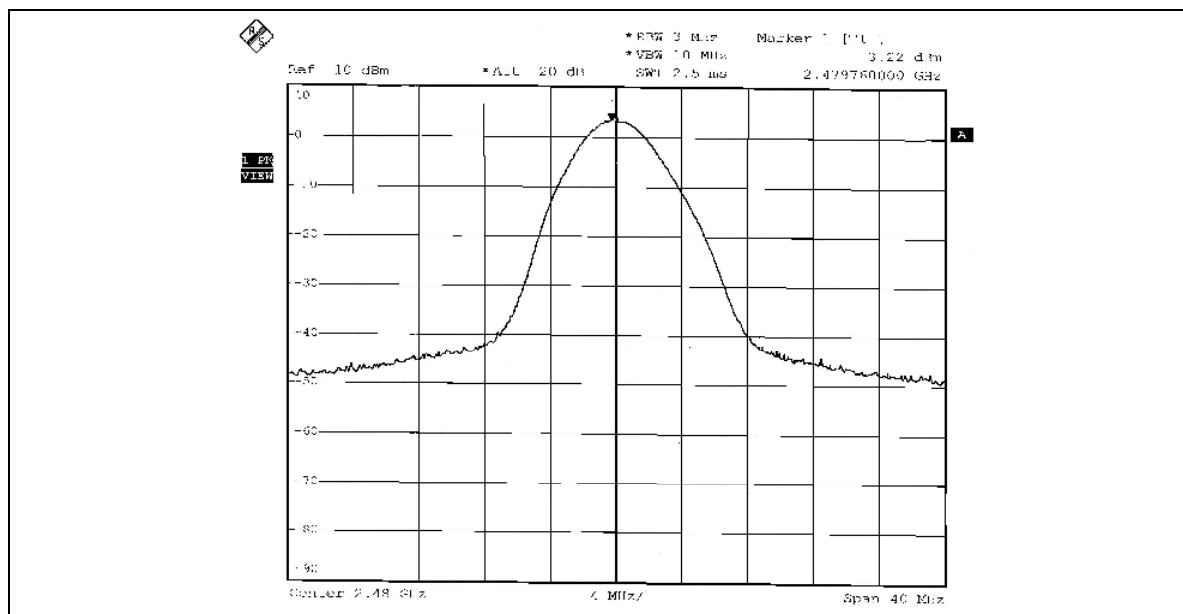

MODE A FOR 8DPSK:

TEST MODE	A		
MODULATION TYPE	8DPSK	CHANNEL	0, 39, 78
INPUT POWER	120Vac, 60 Hz	ENVIRONMENTAL CONDITIONS	26deg. C, 66% RH, 989hPa
TESTED BY	Jamison Chan		

CHANNEL	CHANNEL FREQUENCY (MHz)	PEAK POWER OUTPUT (mW)	PEAK POWER OUTPUT (dBm)	PEAK POWER LIMIT (mW)	PASS/FAIL
0	2402	1.340	1.27	125	PASS
39	2441	1.303	1.15	125	PASS
78	2480	1.172	0.69	125	PASS

CH 0

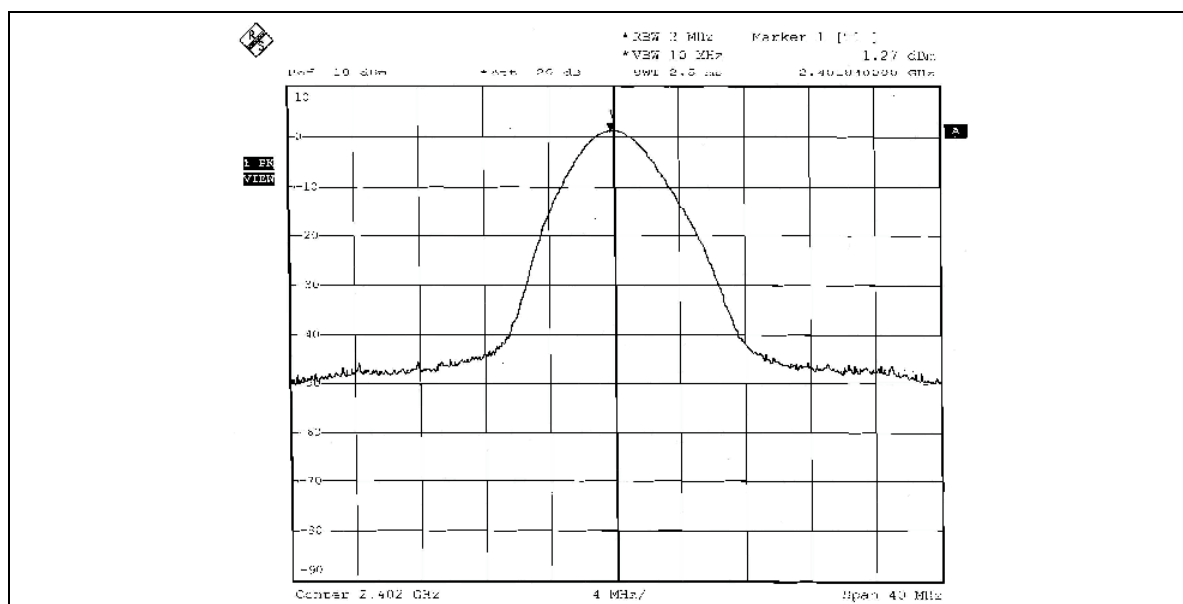

CH 39

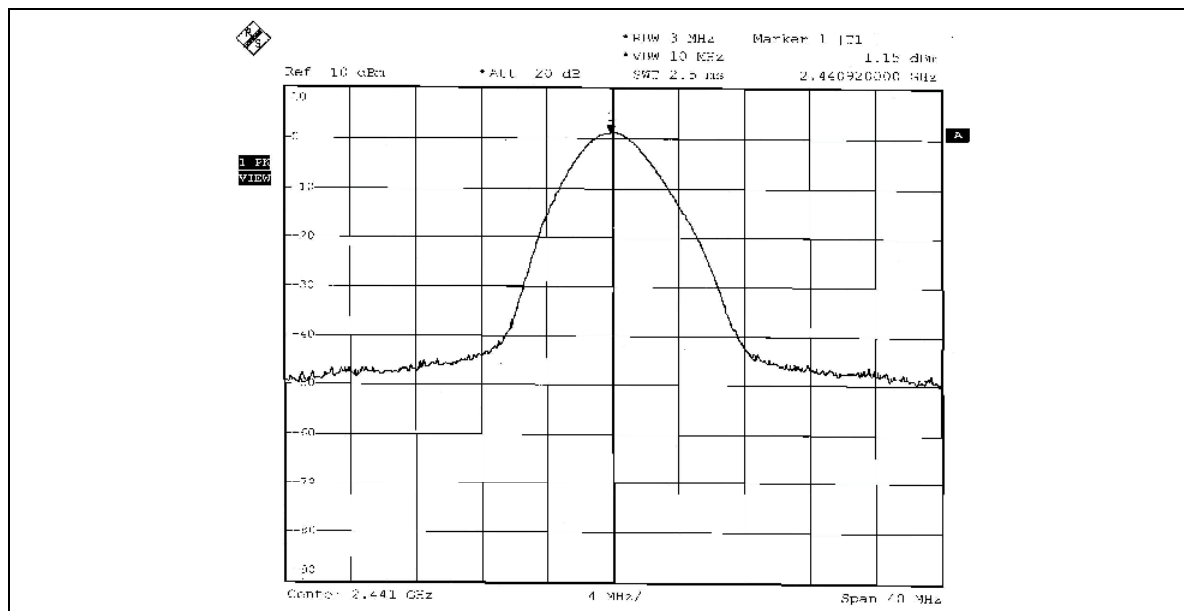

CH 78

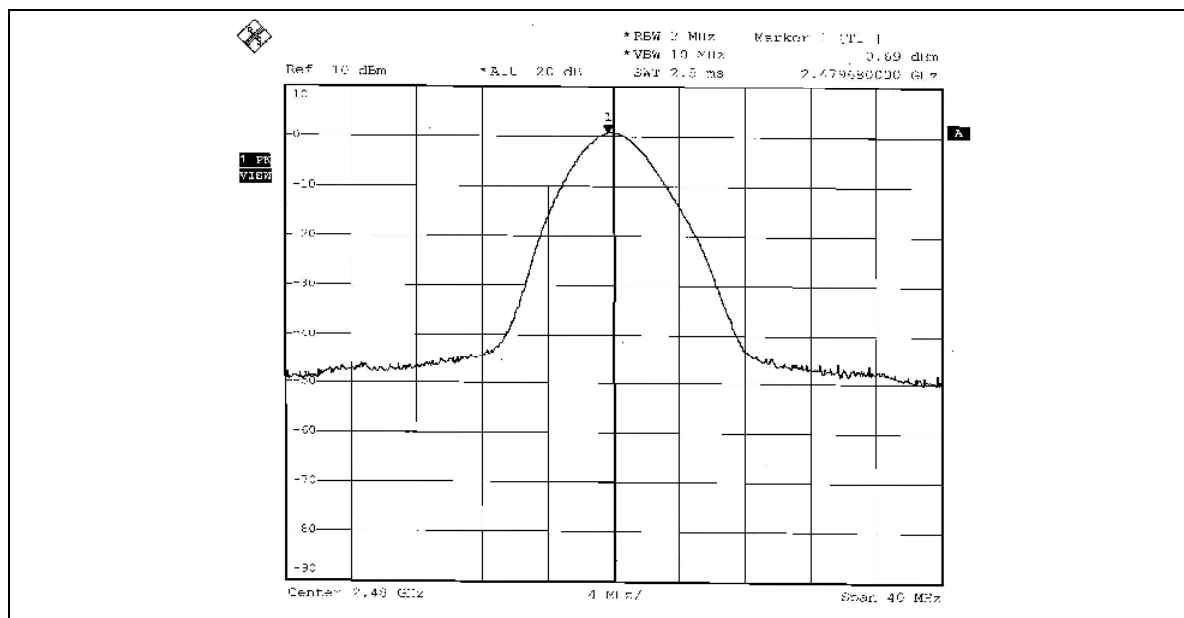

4.8 BAND EDGES MEASUREMENT

4.8.1 LIMITS OF BAND EDGES MEASUREMENT

Below –20dB of the highest emission level of operating band (in 100KHz RBW).

4.8.2 TEST INSTRUMENTS

DESCRIPTION & MANUFACTURER	MODEL NO.	SERIAL NO.	CALIBRATED UNTIL
SPECTRUM ANALYZER	FSP 40	100036	Mar. 16. 2007

NOTES: The calibration interval of the above test instruments is 12 months. And the calibrations are traceable to NML/ROC and NIST/USA.

4.8.3 TEST PROCEDURE

The transmitter output was connected to the spectrum analyzer via a low lose cable. Set both RBW and VBW of spectrum analyzer to 100 kHz with suitable frequency span including 100 MHz bandwidth from band edge. The band edges was measured and recorded.

4.8.4 DEVIATION FROM TEST STANDARD

No deviation.

4.8.5 EUT OPERATING CONDITION

The software provided by client enabled the EUT to transmit and receive data at lowest, middle and highest channel frequencies individually.

4.8.6 TEST RESULTS

The spectrum plots are attached on the following 4 images. D1 line indicates the highest level, D2 line indicates the 20dB offset below D1. It shows compliance with the requirement in part 15.247(d).

MODE A FOR GFSK:

NOTE 1:

The band edge emission plot on page 87 shows 58.49dBc between carrier maximum power and local maximum emission in restrict band (2.3762GHz). The emission of carrier strength list in the test result of channel 0 at the item 4.2.7 is 101.01dBuV/m (Peak), so the maximum field strength in restrict band is $101.01 - 58.49 = 42.52$ dBuV/m, which is under 74 dBuV/m limit.

Average value = $42.52 - 30.00 = 12.52$ dBuV/m, which is under 54dBuV/m limit.

*The DH5 packet was the worse case duty cycle for a transmit dwell time on a channel, based upon bluetooth theory the transmitter is on $0.625 * 5$ per 296.25 ms per channel. Therefore, the duty cycle be equal to: $20\log(3.125/100) = -30$ dB.
Average value = peak reading - 30.00.

NOTE 2:

The band edge emission plot on page 88 shows 46.92dBc between carrier maximum power and local maximum emission in restrict band (2.4845GHz). The emission of carrier strength list in the test result of channel 78 at the item 4.2.7 is 99.21dBuV/m (Peak), so the maximum field strength in restrict band is $99.21 - 46.92 = 52.29$ dBuV/m, which is under 74 dBuV/m limit.

Average value = $52.29 - 30.00 = 22.29$ dBuV/m, which is under 54dBuV/m limit.

*The DH5 packet was the worse case duty cycle for a transmit dwell time on a channel, based upon bluetooth theory the transmitter is on $0.625 * 5$ per 296.25 ms per channel. Therefore, the duty cycle be equal to: $20\log(3.125/100) = -30$ dB.
Average value = peak reading - 30.00.

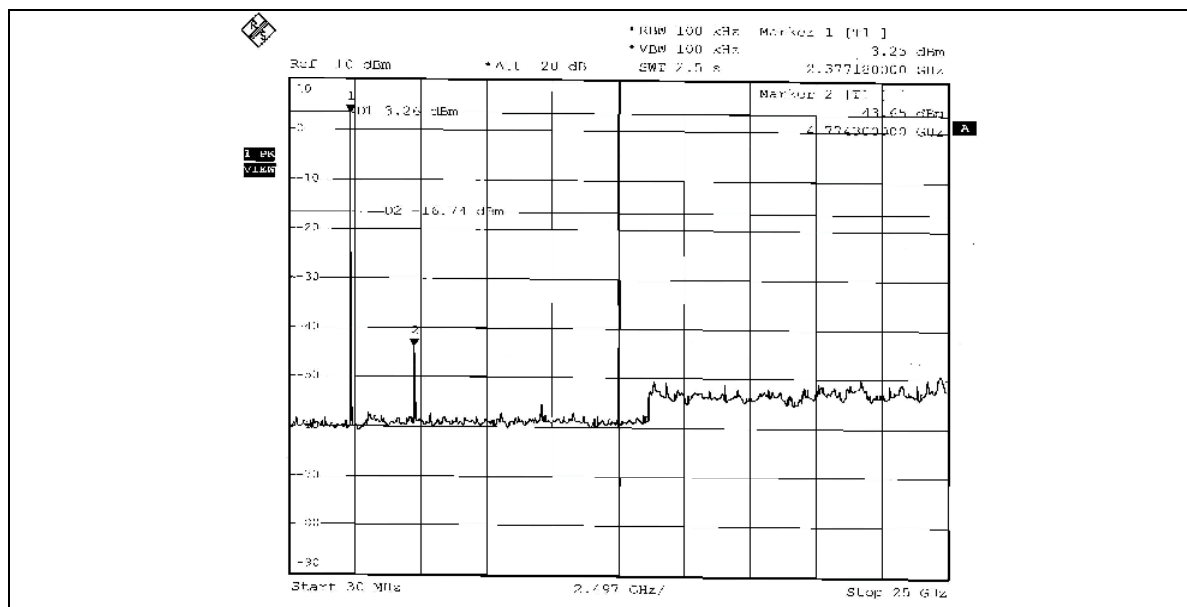
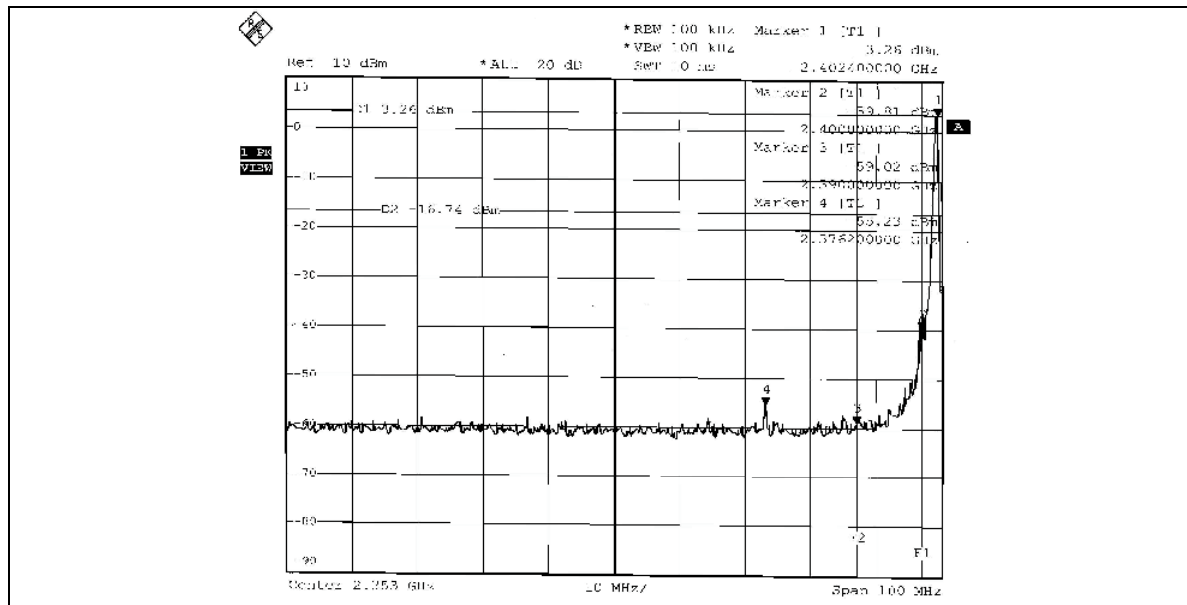

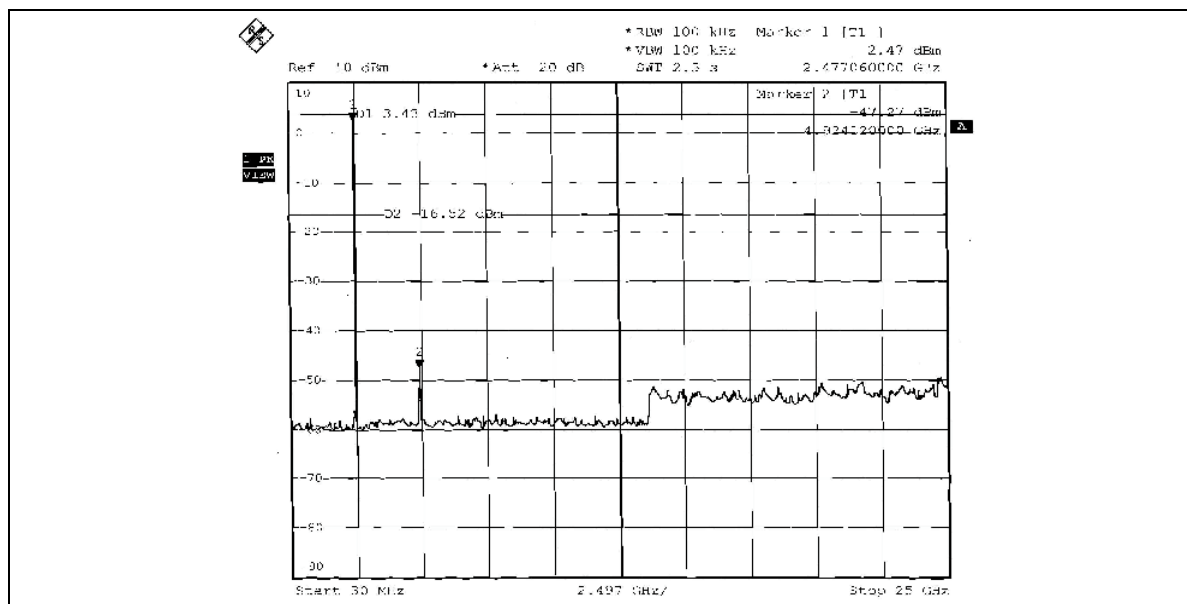
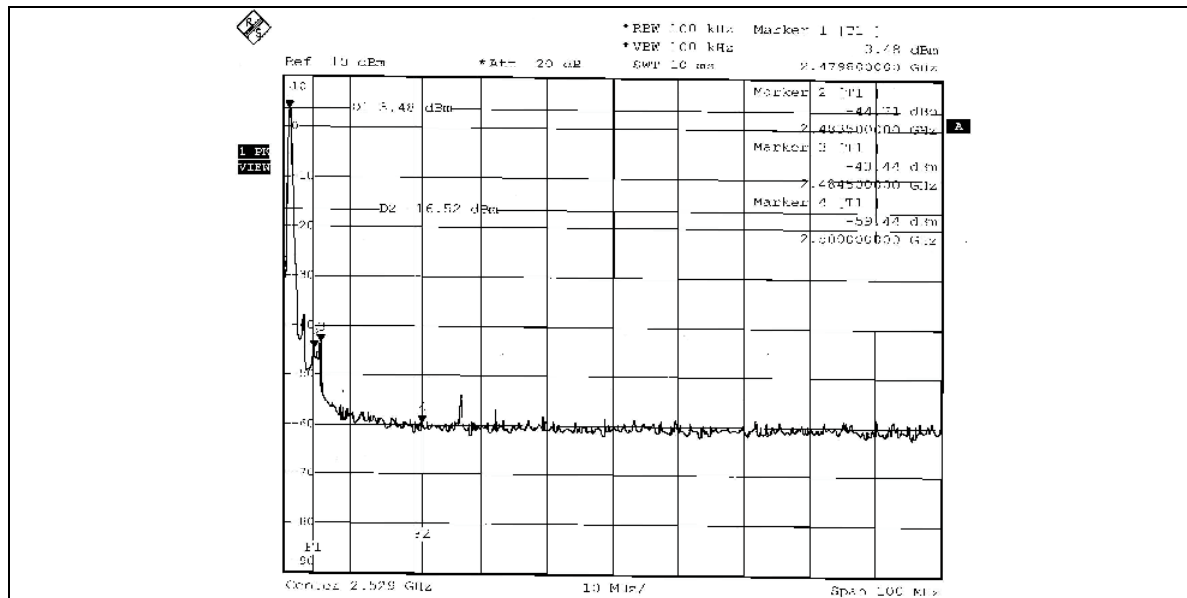

MODE A FOR 8DPSK:

NOTE 1:

The band edge emission plot on page 90 shows 55.12dBc between carrier maximum power and local maximum emission in restrict band (2.3762GHz). The emission of carrier strength list in the test result of channel 0 at the item 4.2.7 is 99.66dBuV/m (Peak), so the maximum field strength in restrict band is $99.66 - 55.12 = 44.54$ dBuV/m, which is under 74 dBuV/m limit.

Average value = $44.54 - 30.00 = 14.54$ dBuV/m, which is under 54dBuV/m limit.

*The DH5 packet was the worse case duty cycle for a transmit dwell time on a channel, based upon bluetooth theory the transmitter is on $0.625 * 5$ per 296.25 ms per channel. Therefore, the duty cycle be equal to: $20\log(3.125/100) = -30$ dB.

Average value = peak reading - 30.00.

NOTE 2:

The band edge emission plot on page 91 shows 45.67dBc between carrier maximum power and local maximum emission in restrict band (2.4835GHz). The emission of carrier strength list in the test result of channel 78 at the item 4.2.7 is 101.99dBuV/m (Peak), so the maximum field strength in restrict band is $101.99 - 45.67 = 56.32$ dBuV/m, which is under 74 dBuV/m limit.

Average value = $56.32 - 30.00 = 26.32$ dBuV/m, which is under 54dBuV/m limit.

*The DH5 packet was the worse case duty cycle for a transmit dwell time on a channel, based upon bluetooth theory the transmitter is on $0.625 * 5$ per 296.25 ms per channel. Therefore, the duty cycle be equal to: $20\log(3.125/100) = -30$ dB.

Average value = peak reading - 30.00.

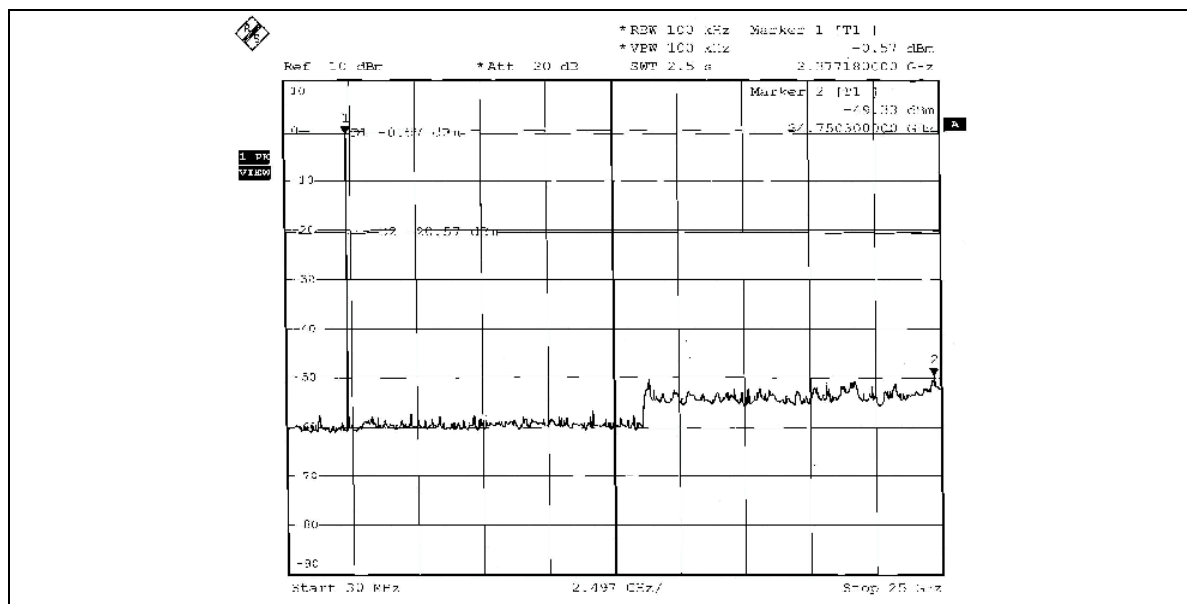
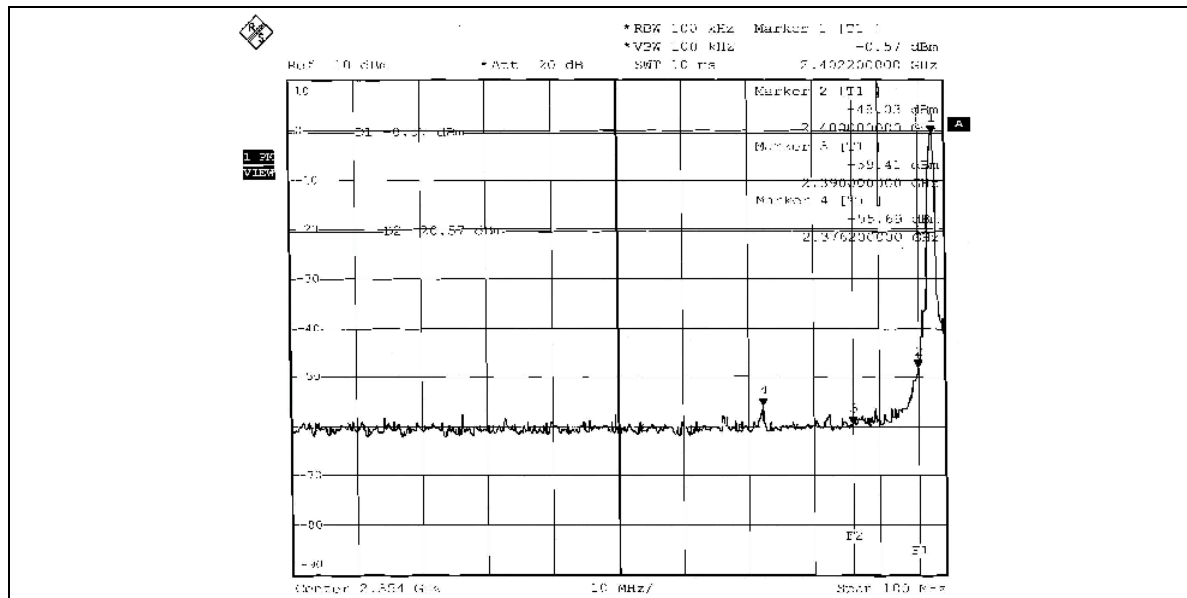

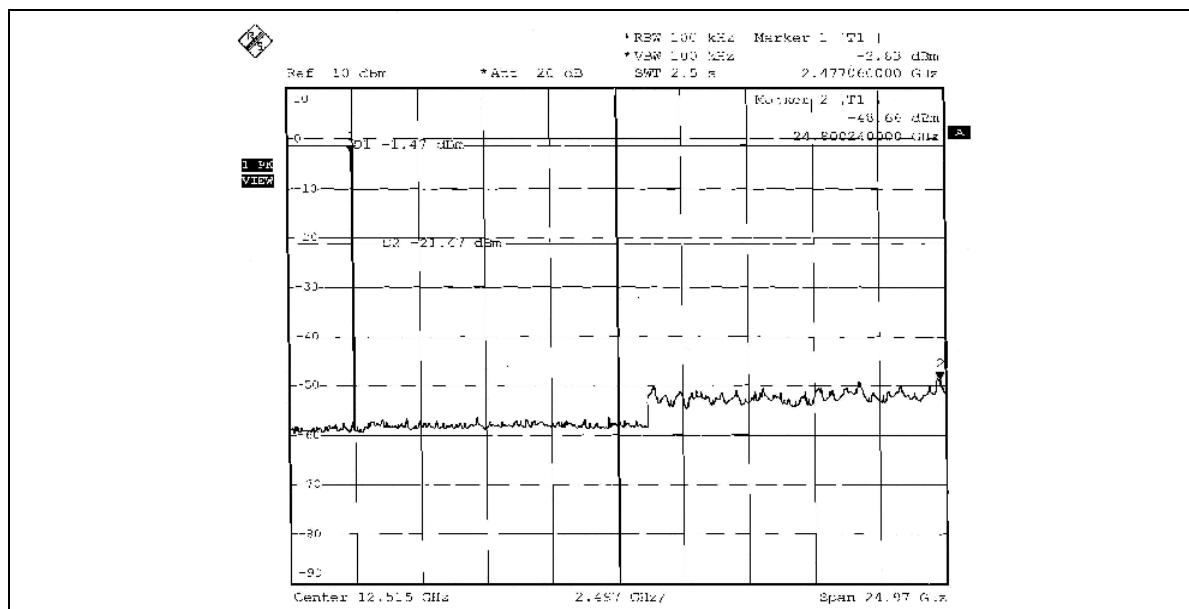
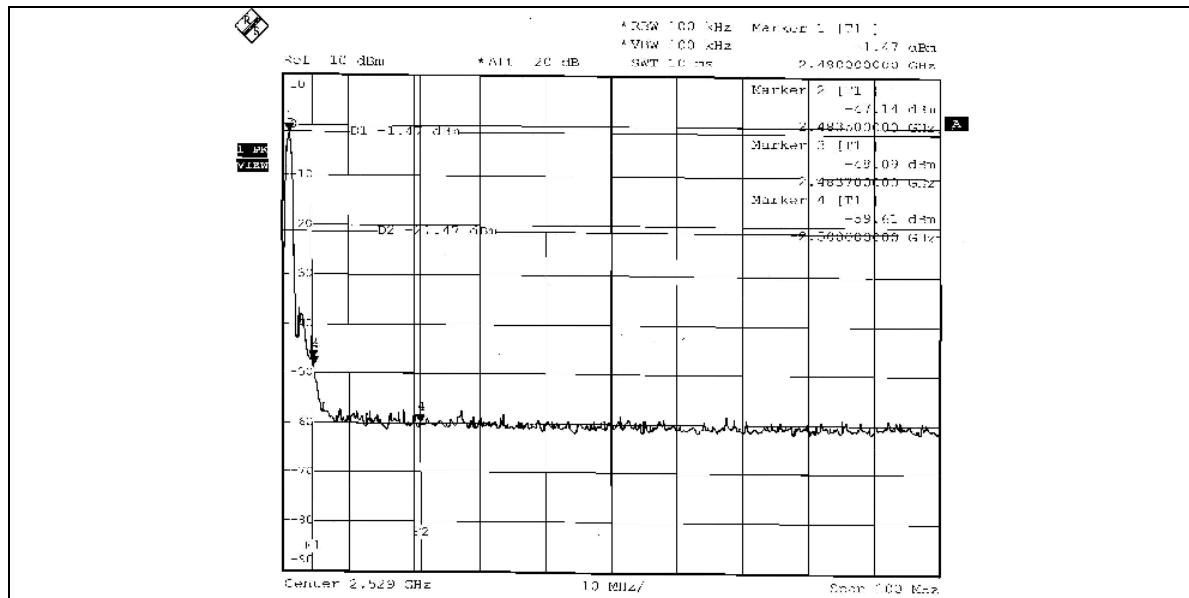

4.9 ANTENNA REQUIREMENT

4.9.1 STANDARD APPLICABLE

For intentional device, according to FCC 47 CFR Section 15.203, an intentional radiator shall be designed to ensure that no antenna other than that furnished by the responsible party shall be used with the device.

And according to FCC 47 CFR Section 15.247 (b), if transmitting antennas of directional gain greater than 6 dBi are used, the power shall be reduced by the amount in dB that the directional gain of the antenna exceeds 6 dBi.

4.9.2 ANTENNA CONNECTED CONSTRUCTION

The antenna used in this product is printed antenna without antenna connector. The maximum gain of this antenna is 0dBi.



5. INFORMATION ON THE TESTING LABORATORIES

We, ADT Corp., were founded in 1988 to provide our best service in EMC, Radio, Telecom and Safety consultation. Our laboratories are accredited and approved by the following approval agencies according to ISO/IEC 17025.

USA	FCC, UL, A2LA
Germany	TUV Rheinland
Japan	VCCI
Norway	NEMKO
Canada	INDUSTRY CANADA , CSA
R.O.C.	CNLA, BSMI, NCC
Netherlands	Telefication
Singapore	PSB , GOST-ASIA(MOU)
Russia	CERTIS(MOU)

Copies of accreditation certificates of our laboratories obtained from approval agencies can be downloaded from our web site:

www.adt.com.tw/index.5/phtml. If you have any comments, please feel free to contact us at the following:

Linko EMC/RF Lab:

Tel: 886-2-26052180

Fax: 886-2-26051924

Hsin Chu EMC/RF Lab:

Tel: 886-3-5935343

Fax: 886-3-5935342

Hwa Ya EMC/RF/Safety Telecom Lab:

Tel: 886-3-3183232

Fax: 886-3-3185050

Web Site: www.adt.com.tw

The address and road map of all our labs can be found in our web site also.



APPENDIX-A

MODIFICATIONS RECORDERS FOR ENGINEERING CHANGES TO THE EUT BY THE LAB

No any modifications are made to the EUT by the lab during the test.