

1 2 3 4 5 6 7

REV. 更改	DESCRIPTION 說明	ENG. 修改人	APPROVAL 審核

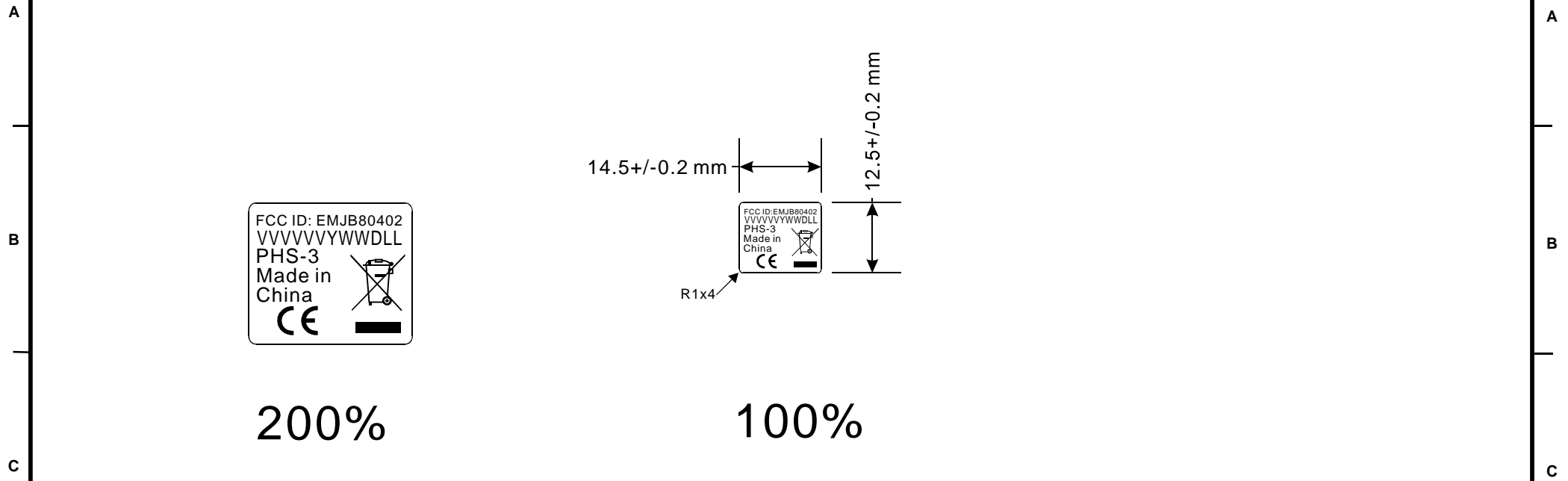

200%

100%

- NOTE :
1. MATERIAL : METALIZED POLYESTER LABEL B-7575.
  2. PRINT COLOR : ALL LETTER ARE BLACK ON SILVERY BACKGROUND.
  3. REVERSE SIDE WITH GLUE.
  4. SERIAL NUMBER ARRANGEMENT : TOTAL 12 DIGITS

VVVVVVYWWDLL

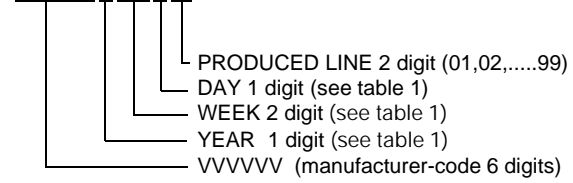

Year	Year Code	Week	Week Code	Day	Day Code
2002	2	1	01	Monday	1
2003	3	2	02	Tuesday	2
2004	4	3	03	Wednesday	3
2005	5	4	04	Thursday	4
2006	6	...	...	Friday	5
2007	7	...	...	Saturday	6
-	-	...	...	Sunday	7
-	-	...	...	-	-
-	-	52	52	-	-

TABLE 1.

Rev.	Change vs. Previous version	Issuer
0.1	Initial draft	Hongming Hu 08/24/2005

<b>DO NOT SCALE DRAWING</b>		<b>PRIMAX</b> 東聚電業有限公司 PRIMAX MANUFACTURING LTD.	
THESE DRAWING AND SPECIFICATIONS ARE THE PROPERTY OF PRIMAX ELECTRONICS LTD AND SHALL NOT BE REPRODUCED COPIED OR USED IN ANY MANNER WITHOUT THE PRIOR WRITTEN CONSENT OF PRIMAX ELECTRONICS LTD.		USED 用途 50-80402PXY0 HS-56W	APPD. 審核 Haoyu Lee
UNLESS OTHERWISE SPECIFIED: DIMENSIONS ARE IN MILLIMETERS ANGULAR TOLERANCE: 1.0		FINISH 處理	CHKD. 校對 Haoyu Lee
DIMENSIONS 0.00 TO 30.00mm	TOLERANCE ±0.10mm	SCALE 比例 /	DR. 製圖 Hongming Hu 08/24/2005
30.01 TO 80.00mm	±0.13mm	UNIT 單位 mm	
80.01 TO 150.00mm	±0.15mm		
150.01 ↑	±0.20mm	TITLE 名稱 TYPE LABEL	
MATERIAL 材質		DWG NO. 圖號 910000129500	SIZE 圖紙 A4
SEE NOTE 2		FILE NAME 檔案名稱 910000129500.CDR	SHEET 張 1/1
		REV. 更改	0.1

6. TO BE PRINTED IN PRODUCTION USING THERMAL TRANSFER RIBBON R-7963 NMP CODE 9730082.
7. ALL DIMENSIONS(5) ARE INCOMING INSPECTION AND CRITICAL.
8. 標誌內容均隨業務訂單及實際生產狀況做變更.
9. Requirement of PRIMAX Green Part:
  1. Comply with PRIMAX QW-5Q002 " Green Product Chemical Substances Specification " .
  2. Follow customer's specification as required.
10. 淨重: 0.04g

1 2 3 4 5 6 7

T-RR024 REVISED JAN. 95 BY THOMAS HSU