

REVISIONS				
REV.	ACC.	DESCRIPTION	DRN.	DATE
1	7/27 MAIL	MODIFY ICON	Eric	2017/7/27
2	8/23 MAIL	MODIFY ICON	Eric	2017/8/23

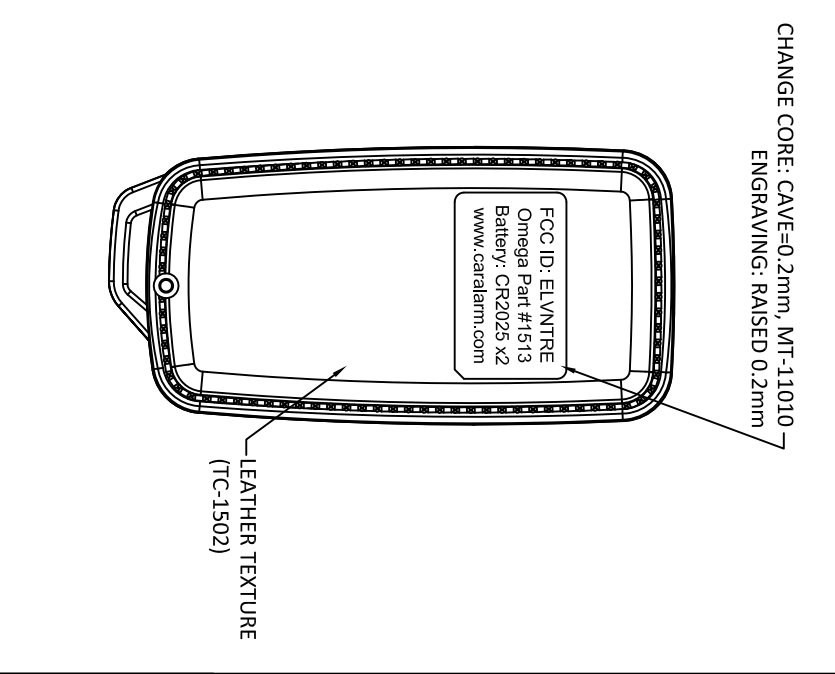
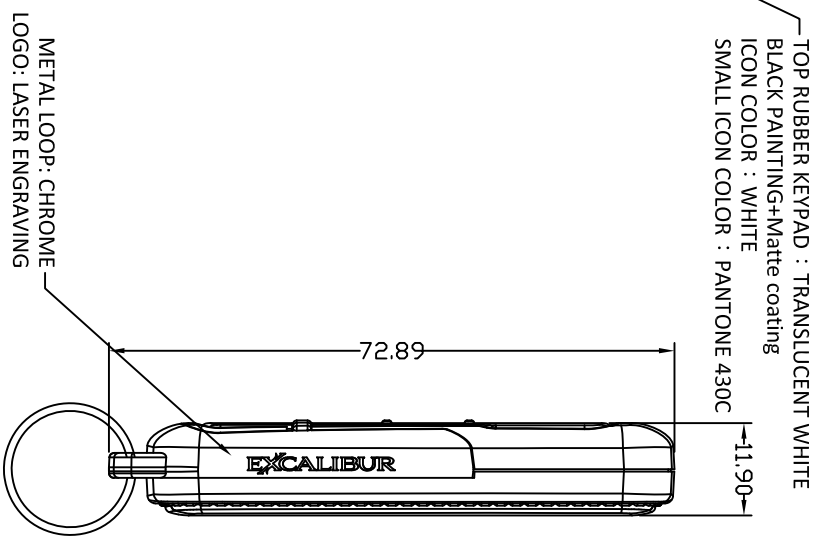
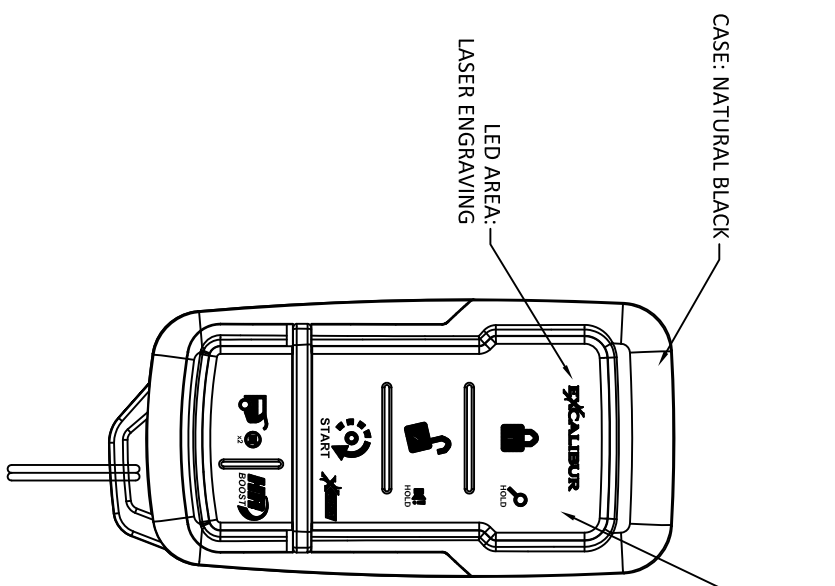
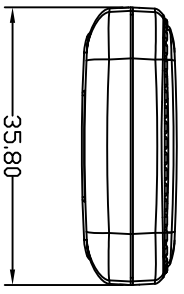

BODY MATERIAL: PC/ABS
 1. Texture is same as MT-11010
 2. Radiious will be 0.2 if not specified.

*Tolerance please refer specification of tolerance units "C" Micr TOLERANCE SPEC.

Dimension	A	B	C
UNDER 3	0.08	0.16	0.30
3-30	0.10	0.20	0.40
30-120	0.20	0.40	0.80
120-300	0.40	0.80	2.00

PART	P/N
CASE	IAER10B0
TOP KEYPAD	NKER1BB0
METAL LOOP	MDER1SA0
BAT. CLIP(+)	MCDB300G
BATTERY	IADB4000
KEY CHAIN	MA150000
SCREW	MIF17005

SCALE: 1:1	UNIT: M/M	DEN BY: ERIC	DATE: 2017/7/7	TITLE: NUTEK CORPORATION
MATERIAL:	CHK BY: YYS	APPD BY: VICTOR	DATE: 2017/8/23	
FINISH:				EXC
CODE:				1513-03E
				SIZE: A4
				DEPT:
				DRAWING NO: 10510080-1
				REV: 2